

CDCVF2505 3.3-V CLOCK PHASE-LOCK LOOP CLOCK DRIVER

SCAS640D – JULY 2000 – REVISED JULY 2002

- **Phase-Lock Loop Clock Driver for Synchronous DRAM and General-Purpose Applications**
- **Spread Spectrum Clock Compatible**
- **Operating Frequency: 24 MHz to 200 MHz**
- **Low Jitter (Cycle-cycle): $<|150\text{ ps}|$ Over the Range 66 MHz–200 MHz**
- **Distributes One Clock Input to One Bank of Five Outputs (CLKOUT Is Used to Tune the Input-Output Delay)**
- **Three-States Outputs When There Is no Input Clock**
- **Operates From Single 3.3-V Supply**
- **Available in 8-Pin TSSOP and 8-Pin SOIC Packages**
- **Consumes Less Than 100 μA (Typically) in Power Down Mode**
- **Internal Feedback Loop Is Used to Synchronize the Outputs to the Input Clock**
- **25- Ω On-Chip Series Damping Resistors**
- **Integrated RC PLL Loop Filter Eliminates the Need for External Components**

D OR PW PACKAGE
(TOP VIEW)

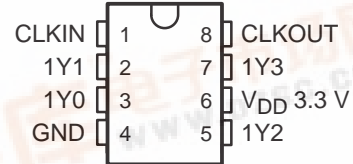

description

The CDCVF2505 is a high-performance, low-skew, low-jitter, phase-lock loop (PLL) clock driver. It uses a PLL to precisely align, in both frequency and phase, the output clocks (1Y[0–3] and CLKOUT) to the input clock signal (CLKIN). The CDCVF2505 operates at 3.3 V. It also provides integrated series-damping resistors that make it ideal for driving point-to-point loads.

One bank of five outputs provides low-skew, low-jitter copies of CLKIN. Output duty cycles are adjusted to 50 percent, independent of duty cycle at CLKIN. The device automatically goes in power-down mode when no input signal is applied to CLKIN.

Unlike many products containing PLLs, the CDCVF2505 does not require an external RC network. The loop filter for the PLLs is included on-chip, minimizing component count, space, and cost.

Because it is based on the PLL circuitry, the CDCVF2505 requires a stabilization time to achieve phase lock of the feedback signal to the reference signal. This stabilization is required following power up and application of a fixed-frequency, fixed-phase signal at CLKIN, and following any changes to the PLL reference.

The CDCVF2505 is characterized for operation from -40°C to 85°C .

Please be aware that an important notice concerning availability, standard warranty, and use in critical applications of Texas Instruments semiconductor products and disclaimers thereto appears at the end of this data sheet.

CDCVF2505

3.3-V CLOCK PHASE-LOCK LOOP CLOCK DRIVER

SCAS640D – JULY 2000 – REVISED JULY 2002

FUNCTION TABLE

INPUT	OUTPUTS	
	1Y (0:3)	CLKOUT
L	L	L
H	H	H
<10 MHz†	Z	Z

† Typically, below 2 MHz the device goes in power-down mode in which the PLL is turned off and the outputs enter into Hi-Z mode. If a >10-MHz signal is applied at CLKIN the PLL turns on, reacquires lock, and stabilizes after approximately 100 μs. The outputs will then be enabled.

functional block diagram

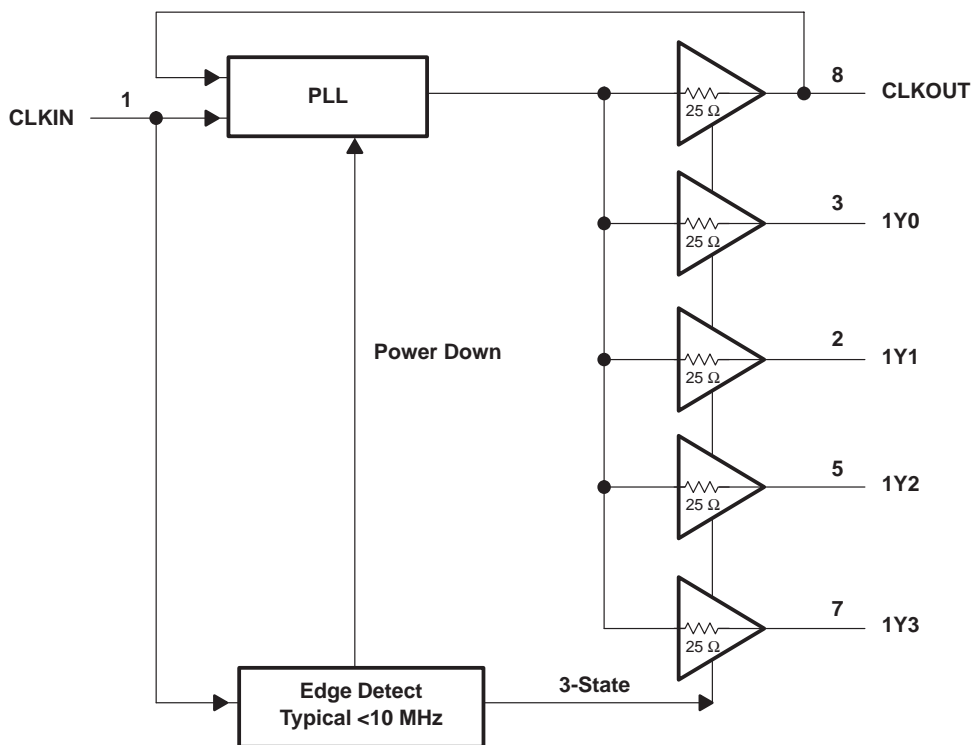

CDCVF2505

3.3-V CLOCK PHASE-LOCK LOOP CLOCK DRIVER

SCAS640D – JULY 2000 – REVISED JULY 2002

Terminal Functions

TERMINAL NAME	NO.	I/O	DESCRIPTION
1Y[0–3]	2, 3, 5, 7	O	Clock outputs. These outputs are low-skew copies of CLKIN. Each output has an integrated 25-Ω series damping resistor.
CLKIN	1	I	Clock input. CLKIN provides the clock signal to be distributed by the CDCVF2505 clock driver. CLKIN is used to provide the reference signal to the integrated PLL that generates the clock output signals. CLKIN must have a fixed frequency and fixed phase for the PLL to obtain phase lock. Once the circuit is powered up and a valid signal is applied, a stabilization time (100 μs) is required for the PLL to phase lock the feedback signal to CLKIN.
CLKOUT	8	O	Feedback output. CLKOUT completes the internal feedback loop of the PLL. This connection is made inside the chip and an external feedback loop should NOT be connected. CLKOUT can be loaded with a capacitor to achieve zero delay between CLKIN and the Y outputs.
GND	4	Power	Ground
V _{DD3.3V}	6	Power	3.3-V Supply

absolute maximum ratings over operating free-air temperature (unless otherwise noted)[†]

Supply voltage range, V _{DD}	–0.5 V to 4.3 V
Input voltage range, V _I (see Notes 1 and 2)	–0.5 V to V _{DD} + 0.5 V
Output voltage range, V _O (see Notes 1 and 2)	–0.5 V to V _{DD} + 0.5 V
Input clamp current, I _{IK} (V _I < 0 or V _I > V _{DD})	±50 mA
Output clamp current, I _{OK} (V _O < 0 or V _O > V _{DD})	±50 mA
Continuous total output current, I _O (V _O = 0 to V _{DD})	±50 mA
Package thermal impedance, θ _{JA} (see Note 3): D package	165.5°C/W
PWR package	230.5°C/W
Storage temperature range, T _{stg}	–65°C to 150°C

[†] Stresses beyond those listed under “absolute maximum ratings” may cause permanent damage to the device. These are stress ratings only, and functional operation of the device at these or any other conditions beyond those indicated under “recommended operating conditions” is not implied. Exposure to absolute-maximum-rated conditions for extended periods may affect device reliability.

- NOTES: 1. The input and output negative-voltage ratings may be exceeded if the input and output clamp-current ratings are observed.
 2. This value is limited to 4.3 V maximum.
 3. The package thermal impedance is calculated in accordance with JESD 51.

recommended operating conditions

	MIN	NOM	MAX	UNIT
Supply voltage, V _{DD}	3	3.3	3.6	V
High-level input voltage, V _{IH}	0.7 V _{DD}			V
Low-level input voltage, V _{IL}	0.3 V _{DD}			V
Input voltage, V _I	0			V _{DD}
High-level output current, I _{OH}				–12 mA
Low-level output current, I _{OL}				12 mA
Operating free-air temperature, T _A	–40			85 °C

CDCVF2505

3.3-V CLOCK PHASE-LOCK LOOP CLOCK DRIVER

SCAS640D – JULY 2000 – REVISED JULY 2002

timing requirements over recommended ranges of supply voltage and operating free-air temperature

		MIN	NOM	MAX	UNIT
f _{clk}	Clock frequency	24		200	MHz
Input clock duty cycle	24 MHz – 85 MHz (see Note 4)	30%		85%	
	86 MHz – 200 MHz	40%	50%	60%	
Stabilization time (see Note 5)				100	μs

- NOTES: 4. Ensured by design but not 100% production tested.
 5. Time required for the integrated PLL circuit to obtain phase lock of its feedback signal to its reference signal. For phase lock to be obtained, a fixed-frequency, fixed-phase reference signal must be present at CLKIN. Until phase lock is obtained, the specifications for propagation delay, skew, and jitter parameters given in the switching characteristics table are not applicable. This parameter does not apply for input modulation under SSC application.

electrical characteristics over recommended operating free-air temperature range (unless otherwise noted)

PARAMETER		TEST CONDITIONS	V _{DD}	MIN	TYP [†]	MAX	UNIT
V _{IK}	Input voltage	I _I = -18 mA	3 V			-1.2	V
V _{OH}	High-level output voltage	I _{OH} = -100 μA	MIN to MAX	V _{DD} -0.2			V
		I _{OH} = -12 mA	3 V	2.1			
		I _{OH} = -6 mA	3 V	2.4			
V _{OL}	Low-level output voltage	I _{OL} = 100 μA	MIN to MAX			0.2	V
		I _{OL} = 12 mA	3 V			0.8	
		I _{OL} = 6 mA	3 V			0.55	
I _{OH}	High-level output current	V _O = 1 V	3 V			-27	mA
		V _O = 1.65 V	3.3 V			-36	
I _{OL}	Low-level output current	V _O = 2 V	3 V			27	mA
		V _O = 1.65 V	3.3 V			40	
I _I	Input current	V _I = 0 V or V _{DD}				±5	μA
C _i	Input capacitance	V _I = 0 V or V _{DD}	3.3 V			4.2	pF
C _o	Output capacitance	Y _n	V _I = 0 V or V _{DD}	3.3 V			pF
		CLKOUT					

[†] All typical values are at respective nominal V_{DD} and 25°C.

switching characteristics over recommended ranges of supply voltage and operating free-air temperature, C_L = 25 pF, V_{DD} = 3.3 V ± 0.3 V (see Note 5)

PARAMETER		TEST CONDITIONS	MIN	TYP [†]	MAX	UNIT
t _{pd}	Propagation delay (normalized (see Figure 3))	CLKIN to Y _n , f = 66 MHz to 200 MHz	-150		150	ps
t _{sk(o)}	Output skew (see Note 6)	Y _n to Y _n			150	ps
t _{c(jit_cc)}	Jitter (cycle to cycle) (see Figure 5)	f = 66 MHz to 200 MHz		70	150	ps
		f = 24 MHz to 50 MHz		200	400	
odc	Output duty cycle (see Figure 4)	f = 24 MHz to 200 MHz at 50% V _{DD}	45%		55%	
t _r	Rise time	V _O = 0.4 V to 2 V	0.5		2	ns
t _f	Fall time	V _O = 2 V to 0.4 V	0.5		2	ns

[†] All typical values are at respective nominal V_{DD} and 25°C.

NOTE 6: The t_{sk(o)} specification is only valid for equal loading of all outputs.

CDCVF2505

3.3-V CLOCK PHASE-LOCK LOOP CLOCK DRIVER

SCAS640D – JULY 2000 – REVISED JULY 2002

ESD information

ESD MODELS	LIMIT
Human Body Model (HBM)	2.0 kV
Machine Model (MM)	300 V
Charge Device Model (CDM)	1 kV

thermal information

CDCVF2505 8-PIN SOIC			THERMAL AIR FLOW (CFM)				UNIT
			0	150	250	500	
R θ JA	High K		97	87	83	77	°C/W
R θ JA	Low K		165	126	113	97	°C/W
R θ JC	High K	39					°C/W
R θ JC	Low K	42					°C/W

CDCVF2505 8-PIN TSSOP			THERMAL AIR FLOW (CFM)				UNIT
			0	150	250	500	
R θ JA	High K		149	142	138	132	°C/W
R θ JA	Low K		230	185	170	150	°C/W
R θ JC	High K	65					°C/W
R θ JC	Low K	69					°C/W

TYPICAL CHARACTERISTICS

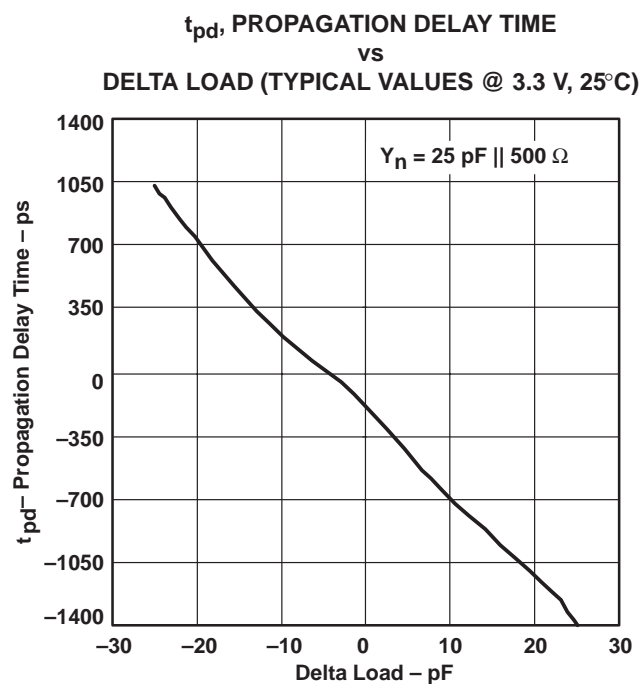

Figure 1

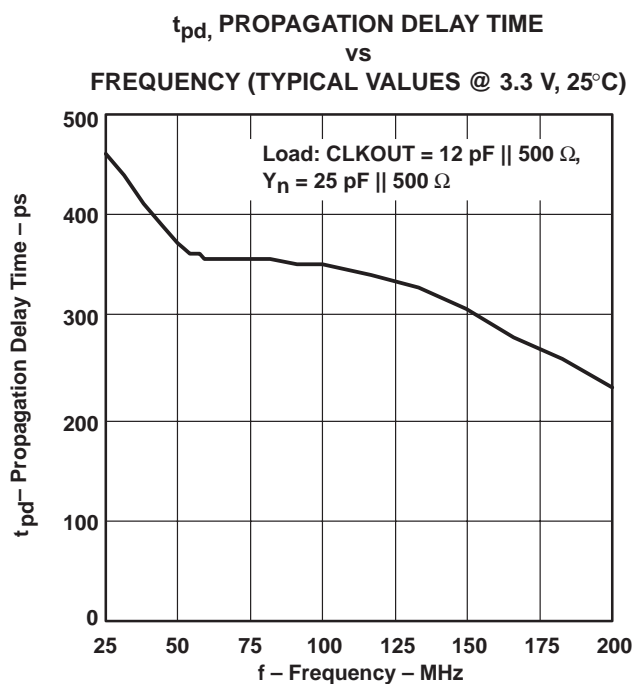

Figure 2

NOTE: Delta Load = CLKOUT Load – Y_n Load

CDCVF2505

3.3-V CLOCK PHASE-LOCK LOOP CLOCK DRIVER

SCAS640D – JULY 2000 – REVISED JULY 2002

TYPICAL CHARACTERISTICS

t_{pd} , TYPICAL PROPAGATION DELAY TIME
vs
FREQUENCY(TUNED FOR MINIMUM DELAY)

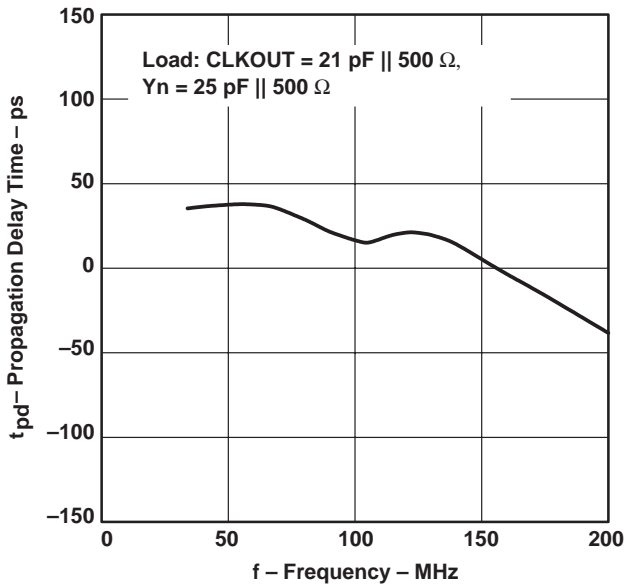

Figure 3

DUTY CYCLE
vs
FREQUENCY

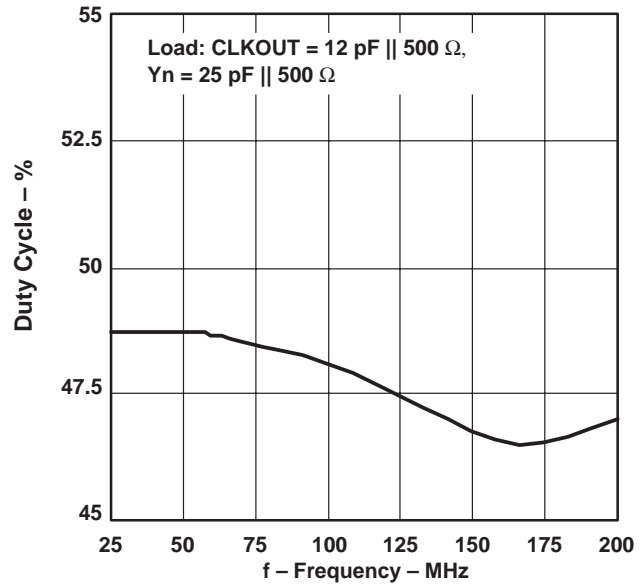

Figure 4

CYCLE-CYCLE JITTER
vs
FREQUENCY

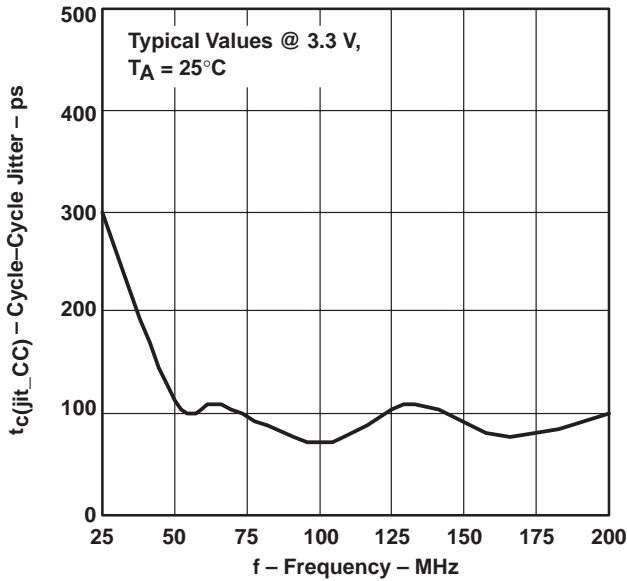

Figure 5

I_{CC} , SUPPLY CURRENT
vs
FREQUENCY

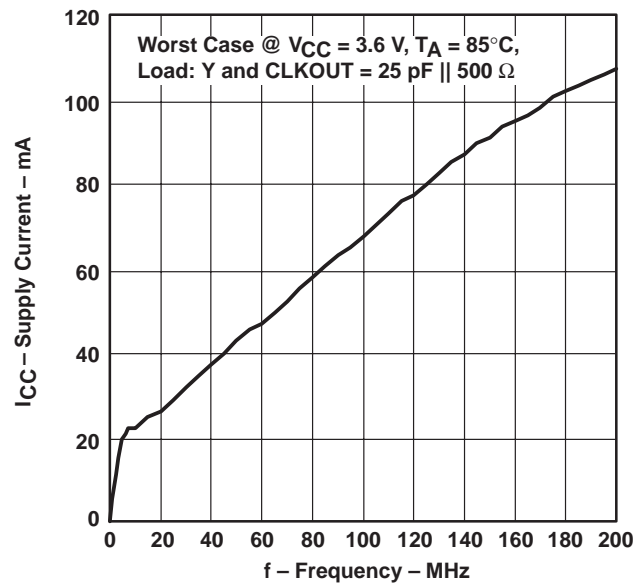

Figure 6

PARAMETER MEASUREMENT INFORMATION

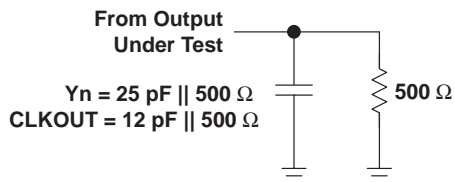

Figure 7. Test Load Circuit

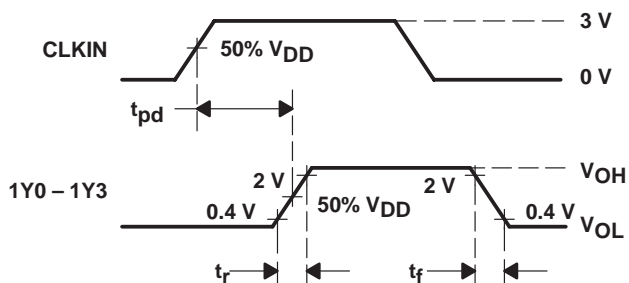

Figure 8. Voltage Threshold for Measurements, Propagation Delay (t_{pd})

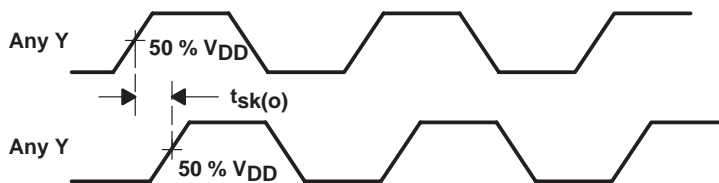

Figure 9. Output Skew

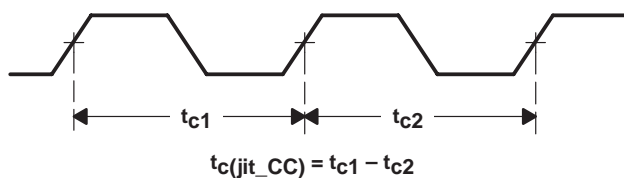
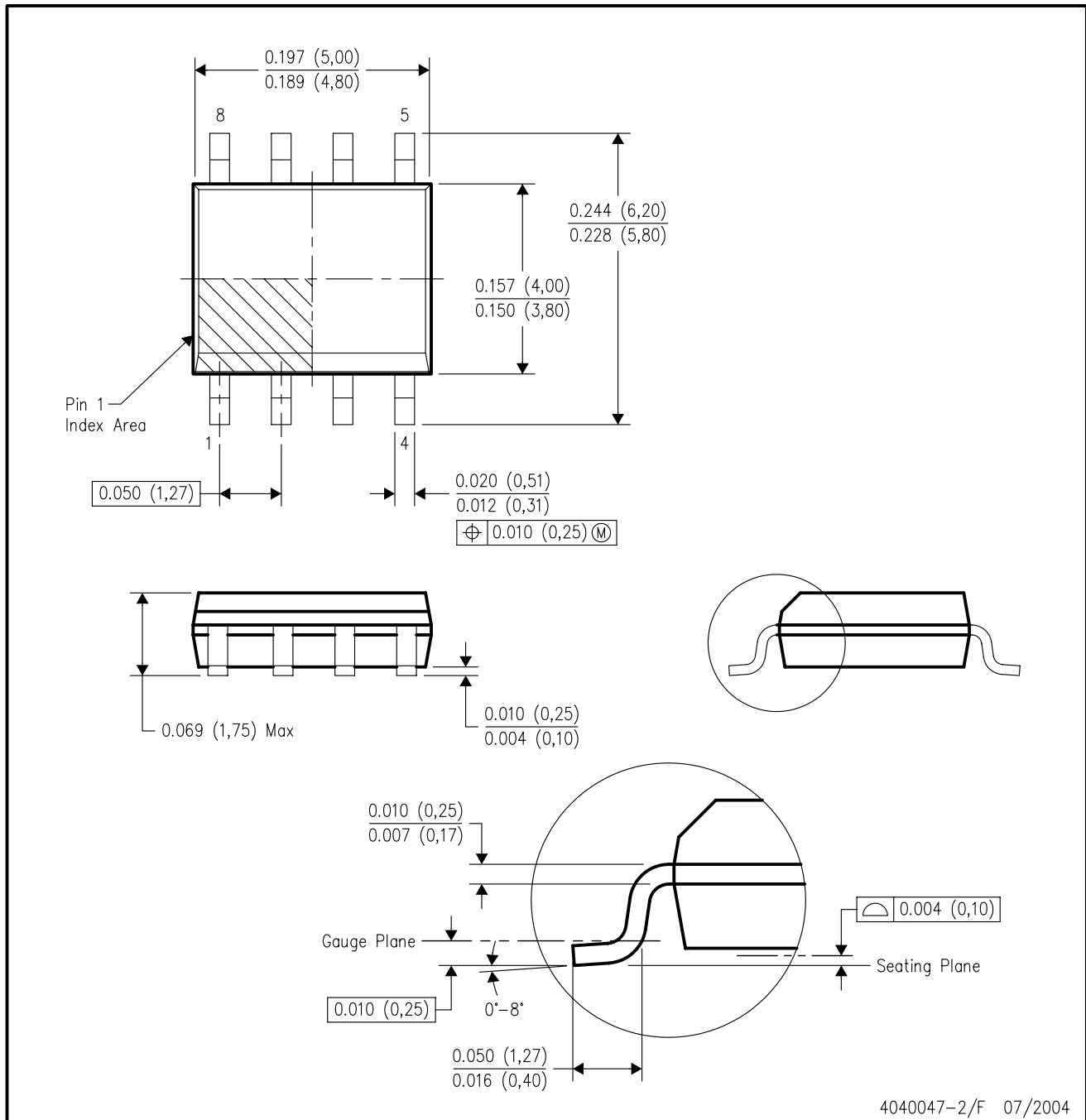

Figure 10. Cycle-to-Cycle Jitter

MECHANICAL DATA

D (R-PDSO-G8)

PLASTIC SMALL-OUTLINE PACKAGE



- NOTES:
- A. All linear dimensions are in inches (millimeters).
 - B. This drawing is subject to change without notice.
 - C. Body dimensions do not include mold flash or protrusion not to exceed 0.006 (0,15).
 - D. Falls within JEDEC MS-012 variation AA.

MECHANICAL DATA

MTSS001C – JANUARY 1995 – REVISED FEBRUARY 1999

PW (R-PDSO-G)**

PLASTIC SMALL-OUTLINE PACKAGE

14 PINS SHOWN

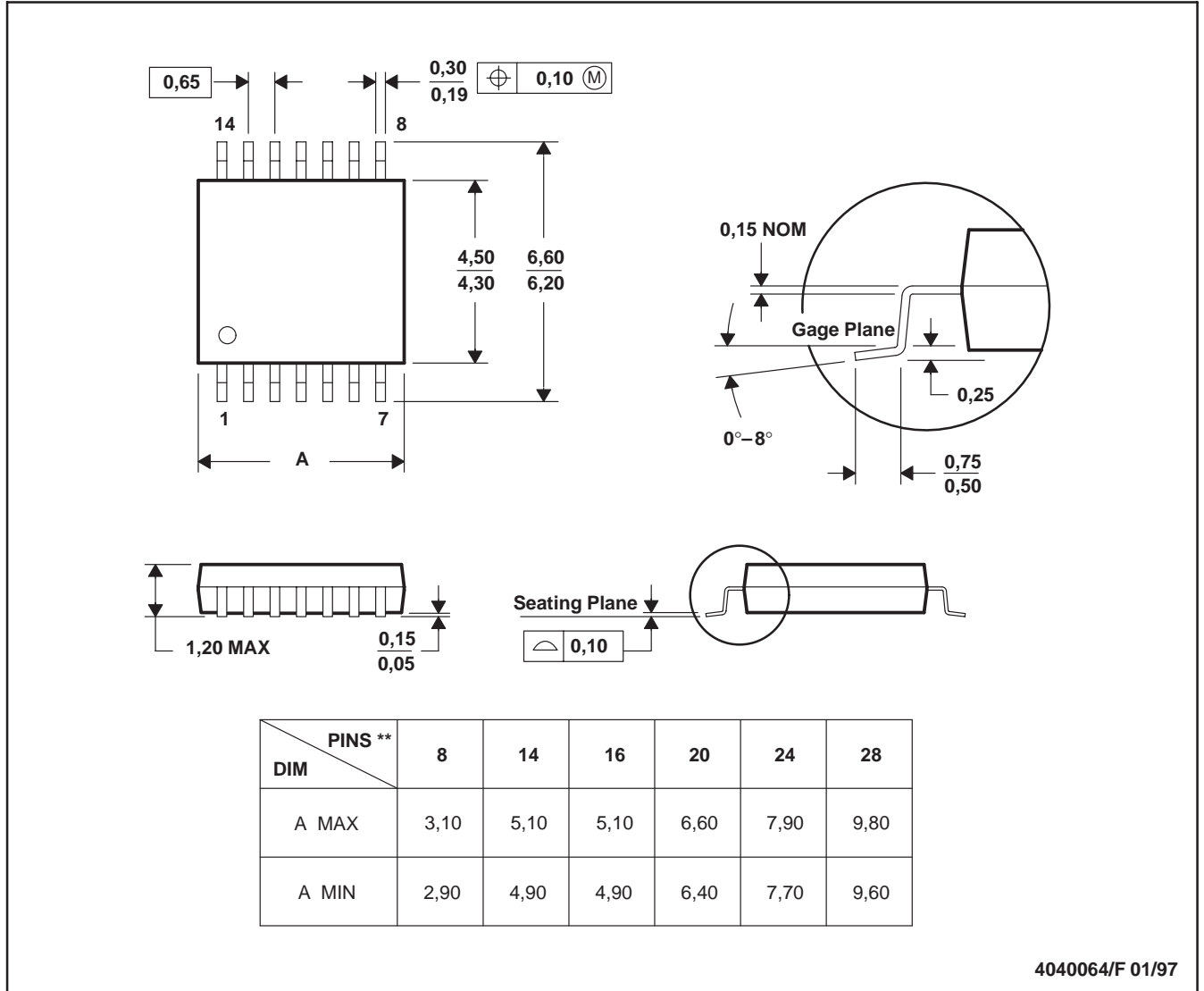

- NOTES:
- All linear dimensions are in millimeters.
 - This drawing is subject to change without notice.
 - Body dimensions do not include mold flash or protrusion not to exceed 0,15.
 - Falls within JEDEC MO-153

IMPORTANT NOTICE

Texas Instruments Incorporated and its subsidiaries (TI) reserve the right to make corrections, modifications, enhancements, improvements, and other changes to its products and services at any time and to discontinue any product or service without notice. Customers should obtain the latest relevant information before placing orders and should verify that such information is current and complete. All products are sold subject to TI's terms and conditions of sale supplied at the time of order acknowledgment.

TI warrants performance of its hardware products to the specifications applicable at the time of sale in accordance with TI's standard warranty. Testing and other quality control techniques are used to the extent TI deems necessary to support this warranty. Except where mandated by government requirements, testing of all parameters of each product is not necessarily performed.

TI assumes no liability for applications assistance or customer product design. Customers are responsible for their products and applications using TI components. To minimize the risks associated with customer products and applications, customers should provide adequate design and operating safeguards.

TI does not warrant or represent that any license, either express or implied, is granted under any TI patent right, copyright, mask work right, or other TI intellectual property right relating to any combination, machine, or process in which TI products or services are used. Information published by TI regarding third-party products or services does not constitute a license from TI to use such products or services or a warranty or endorsement thereof. Use of such information may require a license from a third party under the patents or other intellectual property of the third party, or a license from TI under the patents or other intellectual property of TI.

Reproduction of information in TI data books or data sheets is permissible only if reproduction is without alteration and is accompanied by all associated warranties, conditions, limitations, and notices. Reproduction of this information with alteration is an unfair and deceptive business practice. TI is not responsible or liable for such altered documentation.

Resale of TI products or services with statements different from or beyond the parameters stated by TI for that product or service voids all express and any implied warranties for the associated TI product or service and is an unfair and deceptive business practice. TI is not responsible or liable for any such statements.

Following are URLs where you can obtain information on other Texas Instruments products and application solutions:

Products		Applications	
Amplifiers	amplifier.ti.com	Audio	www.ti.com/audio
Data Converters	dataconverter.ti.com	Automotive	www.ti.com/automotive
DSP	dsp.ti.com	Broadband	www.ti.com/broadband
Interface	interface.ti.com	Digital Control	www.ti.com/digitalcontrol
Logic	logic.ti.com	Military	www.ti.com/military
Power Mgmt	power.ti.com	Optical Networking	www.ti.com/opticalnetwork
Microcontrollers	microcontroller.ti.com	Security	www.ti.com/security
		Telephony	www.ti.com/telephony
		Video & Imaging	www.ti.com/video
		Wireless	www.ti.com/wireless

Mailing Address: Texas Instruments
Post Office Box 655303 Dallas, Texas 75265