

LOW JITTER CLOCK MULTIPLIER AND DIVIDER WITH PROGRAMMABLE DELAY AND PHASE ALIGNMENT

SCAS813A – AUGUST 2005 – REVISED DECEMBER 2005

- Low Jitter Clock Multiplier by x4, x6, x8. Input Frequency Range (19 MHz to 125 MHz). Supports Output Frequency From 150 MHz to 500 MHz
- Fail-Safe Power Up Initialization
- Low Jitter Clock Divider by /2, /3, /4. Input Frequency Range (50 MHz to 125 MHz). Supports Ranges of Output Frequency From 12.5 MHz to 62.5 MHz
- 2.6 mUI Programmable Bidirectional Delay Steps
- Typical 8-ps Phase Jitter (12 kHz to 20 MHz) at 500 MHz
- Typical 2.1-ps RMS Period Jitter (Entire Frequency Band) at 500 MHz
- One Single-Ended Input and One Differential Output Pair
- Output Can Drive LVPECL, LVDS, and LVTTTL
- Three Power Operating Modes to Minimize Power
- Low Power Consumption (Typical 200 mW at 500 MHz)
- Packaged in a Shrink Small-Outline Package (DBQ)
- No External Components Required for PLL
- Spread Spectrum Clock Tracking Ability to Reduce EMI
- Applications: Video Graphics, Gaming Products, Datacom, Telecom
- Accepts LVCMOS, LVTTTL Inputs for REFCLK Terminal
- Accepts Other Single-Ended Signal Levels at REFCLK Terminal by Programming Proper V_{DDREF} Voltage Level (For Example, HSTL 1.5 if $V_{DDREF} = 1.6$ V)
- Supports Industrial Temperature Range of -40°C to 85°C

DBQ PACKAGE
(TOP VIEW)

V_{DDREF}	1	24	P0
REFCLK	2	23	P1
V_{DDP}	3	22	V_{DDO}
GNDP	4	21	GNDO
GND	5	20	CLKOUT
LEADLAG	6	19	NC
DLYCTRL	7	18	CLKOUTB
GNDPA	8	17	GNDO
V_{DDPA}	9	16	V_{DDO}
V_{DDPD}	10	15	MULT0/DIV0
STOPB	11	14	MULT1/DIV1
PWRDNB	12	13	P2

NC – No internal connection

description

The CDC5801A device provides clock multiplication and division from a single-ended reference clock (REFCLK) to a differential output pair (CLKOUT/CLKOUTB). The multiply and divide terminals (MULT/DIV0:1) provide selection for frequency multiplication and division ratios, generating CLKOUT/CLKOUTB frequencies ranging from 12.5 MHz to 500 MHz with a clock input reference (REFCLK) ranging from 19 MHz to 125 MHz. See Table 1 and Table 2 for detail frequency support.

The implemented phase aligner provides the possibility to phase align (zero delay) between CLKOUT/CLKOUTB and REFCLK or any other CLK in the system by feeding the clocks that need to be aligned to the DLYCTRL and the LEADLAG terminals.

The phase aligner also allows the user to delay or advance the CLKOUT/CLKOUTB with steps of 2.6 mUI (unit interval). For every rising edge on the DLYCTRL terminal, the output clocks are delayed by 2.6-mUI step size as long as there is low on the LEADLAG terminal. Similarly, for every rising edge on the DLYCTRL terminal, the output clocks are advanced by 2.6-mUI step size as long as there is high on the LEADLAG terminal. The CDC5801A has a fail-safe power up initialization state-machine which supports proper operation under all power up conditions. As the phase between REFCLK and CLKOUT/CLKOUTB is random after power up, the application may implement a self calibration routine at power up to produce a certain phase start position, before programming a fixed delay with the clock on the DLYCTRL terminal.



Please be aware that an important notice concerning availability, standard warranty, and use in critical applications of Texas Instruments semiconductor products and disclaimers thereto appears at the end of this data sheet.

PRODUCTION DATA information is current as of publication date. Products conform to specifications per the terms of Texas Instruments standard warranty. Production processing does not necessarily include testing of all parameters.

 **TEXAS
INSTRUMENTS**

POST OFFICE BOX 655303 • DALLAS, TEXAS 75265

Copyright © 2005, Texas Instruments Incorporated

CDC5801A

LOW JITTER CLOCK MULTIPLIER AND DIVIDER WITH PROGRAMMABLE DELAY AND PHASE ALIGNMENT

SCAS813A – AUGUST 2005 – REVISED DECEMBER 2005

Depending on the selection of the mode terminals (P0:2), the device behaves as a multiplier (by 4, 6, or 8) with the phase aligner bypassed or as a multiplier or divider with programmable delay and phase aligner functionality. Through the select terminals (P0:2) user can also bypass the phase aligner and the PLL (test mode) and output the REFCLK directly on the CLKOUT/CLKOUTB terminals. Through P0:2 terminals the outputs could be in a high impedance state. This device has another unique capability to be able to function with a wide band of voltages on the REFCLK terminal by varying the voltage on the V_{DDREF} terminal.

The CDC5801A has a fail-safe power up initialization state-machine which supports proper operation under all power up conditions.

The CDC5801A device is characterized for operation over free-air temperatures of –40°C to 85°C.

functional block diagram

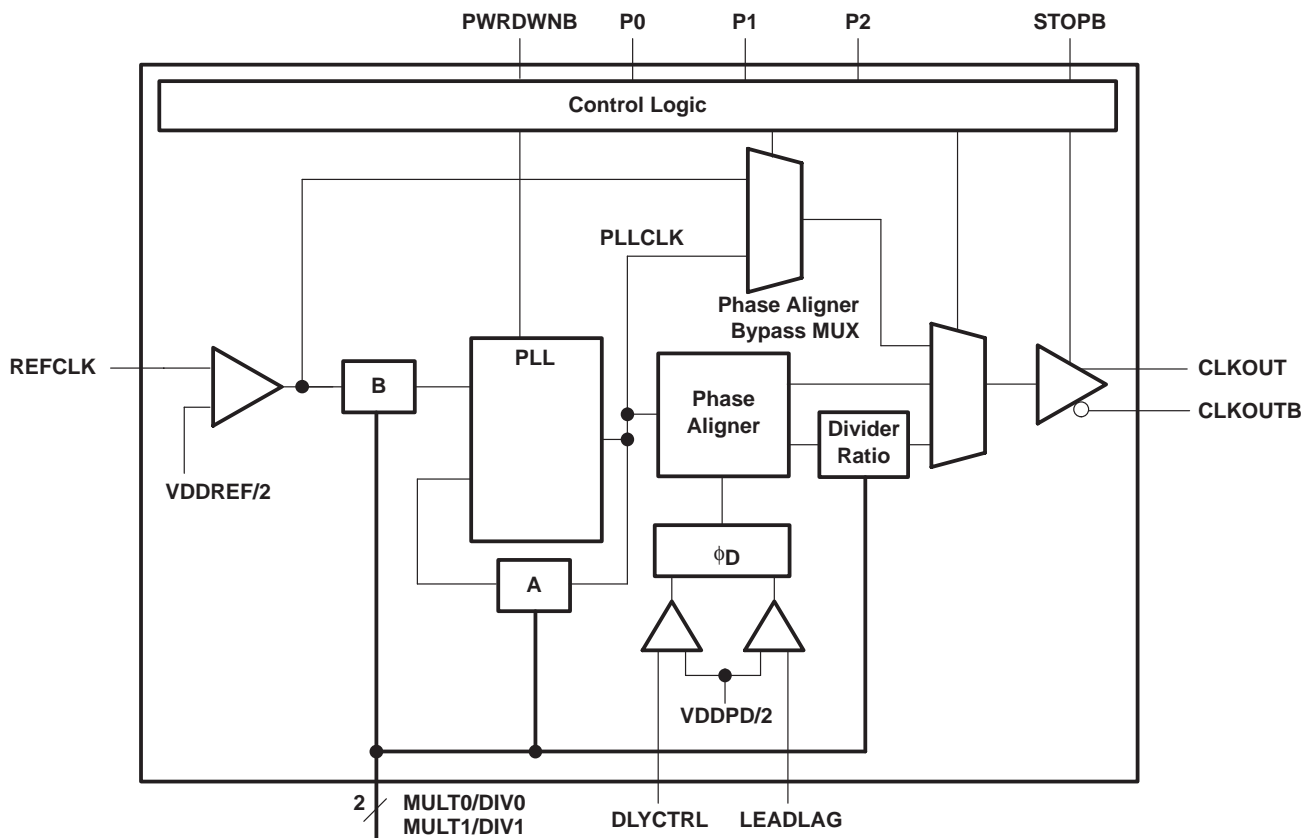

CDC5801A

LOW JITTER CLOCK MULTIPLIER AND DIVIDER WITH PROGRAMMABLE DELAY AND PHASE ALIGNMENT

SCAS813A – AUGUST 2005 – REVISED DECEMBER 2005

FUNCTION TABLE†

MODE	P0	P1	P2	CLKOUT/CLKOUTB
Multiplication with programmable delay and phase alignment active‡	0	0	0	REFCLK multiplied by ratio per Table 1 selected by MULT/DIV terminals. Outputs are delayed or advanced based on DLYCTRL and LEADLAG terminal configuration.
Division with programmable delay and phase alignment active ‡	0	0	1	REFCLK divided by ratio per Table 2 selected by MULT/DIV terminals. Outputs are delayed or advanced based on DLYCTRL and LEADLAG terminal configuration.
Multiplication only mode (phase aligner bypassed) §	1	0	0	In this mode one can only multiply as per Table 1. Programmable delay capability and divider capability is deactivated. PLL is running.
Test mode	1	1	0	PLL and phase aligner both bypassed. REFCLK is directly channeled to output.
Hi-Z mode	0	1	X	Hi-Z

† X = don't care, Hi-Z = high impedance

‡ Please see Table 4 and Table 5 for explanation for the programmability and phase alignment functions.

§ In this mode the DLYCTRL and LEADLAG terminals must be strapped high or low. Lowest possible jitter is achieved in this mode, but a delay of 200 ps to 2 ns expected typically from REFCLK to CLKOUT depending on the output frequency.

Terminal Functions

TERMINAL NAME	NO.	I/O	DESCRIPTION
CLKOUT	20	O	Output clock
CLKOUTB	18	O	Output clock (complement)
DLYCTRL	7	I	Every rising edge on this terminal delays/advances the CLKOUT/CLKOUTB signal by 1/384th of the CLKOUT/CLKOUTB period. (e.g., for a 90 degree delay or advancement one needs to provide 96 rising edges). See Table 4.
GND	5		GND for V _{DDREF} and V _{DDPD}
GNDO	17, 21		GND for clock output terminals (CLKOUT, CLKOUTB)
GNDP	4		GND for PLL
GNDPA	8		GND for phase aligner
LEADLAG	6	I	Decides if the output clock is delayed or advanced with respect to REFCLK. See Table 4.
MULT0/DIV0	15	I	PLL multiplier and divider select
MULT1/DIV1	14	I	PLL multiplier and divider select
NC	19		Not used
PWRDNB	12	I	Active low power down state, CLKOUT/CLKOUTB goes low
P0	24	I	Mode control, see the Function Table
P1	23	I	Mode control, see the Function Table
P2	13	I	Mode control, see the Function Table
REFCLK	2	I	Reference input clock
STOPB	11	I	Active low output disabler, PLL and PA still running, CLKOUT and CLKOUTB goes to a dc value as per Table 3
V _{DDPA}	9	I	Supply voltage for phase aligner
V _{DDPD}	10	I	Reference voltage for the DLYCTRL, LEADLAG terminals and STOPB function
V _{DDREF}	1	I	Reference voltage for REFCLK
V _{DDO}	16, 22	I	Supply voltage for the output terminals (CLKOUT, CLKOUTB)
V _{DDP}	3	I	Supply voltage for PLL

CDC5801A
LOW JITTER CLOCK MULTIPLIER AND DIVIDER WITH
PROGRAMMABLE DELAY AND PHASE ALIGNMENT

SCAS813A – AUGUST 2005 – REVISED DECEMBER 2005

PLL divider/multiplier selection

Table 1 and Table 2 list the supported REFCLK and BUSCLK (CLKOUT/CLKOUTB) frequencies.

Table 1. Multiplication Ratios (P0:2 = 000 or 100)

MULT0	MULT1	REFCLK (MHZ)	MULTIPLICATION RATIO	BUSCLK (MHZ)
0	0	38–125	4	152–500
0	1	25–83.3	6	150–500
1	1	19–62.5	8	152–500

Table 2. Divider Ratio (P0:2 = 001)

MULT0	MULT1	REFCLK (MHZ)	DIVISION RATIO	BUSCLK ⁽¹⁾ (MHZ)
0	0	100–125	2	50–62.5
1	0	75–93	3	25–31
1	1	50–62	4	12.5–15.5

[†] BUSCLK will be undefined until a valid reference clock is available at REFCLK. After applying REFCLK, the PLL requires stabilization time to achieve phase lock.

Table 3. Clock Output Driver States

STATE	PWRDNB	STOPB	CLKOUT	CLKOUTB
Powerdown	0	X	GND	GND
CLK stop	1	0	V _O , STOP	V _O , STOP
Normal	1	1	As per Function Table	As per Function Table

Table 4. Programmable Delay and Phase Alignment

DLYCTRL	LEADLAG	CLKOUT AND CLKOUTB
Each rising edge [†]	1	Will be advanced by one step size (see Table 5)
Each rising edge [†]	0	Will be delayed by one step size (see Table 5)

[†] For every 32nd edge, there are one or two edges the phase aligner does not update. Therefore, CLKOUT phase is not updated on every 32nd edge.

Table 5. Clock Output Driver States

FUNCTIONALITY	STEP SIZE
Multiply by 4, 6, 8	CLKOUT period/384 (for example, 6.5 ps at 400 MHz)
Divide by 2	CLKOUT period/3072 (for example, 6.5 ps at 50 MHz)
Divide by 3	CLKOUT period/6144 (for example, 6.5 ps at 25 MHz)
Divide by 4	CLKOUT period/12288 (for example, 6.5 ps at 12.5 MHz)

NOTE: The frequency of the DLYCTRL terminal must always be equal or less than the frequency of the LEADLAG terminal.



CDC5801A

LOW JITTER CLOCK MULTIPLIER AND DIVIDER WITH PROGRAMMABLE DELAY AND PHASE ALIGNMENT

SCAS813A – AUGUST 2005 – REVISED DECEMBER 2005

absolute maximum ratings over operating free-air temperature (unless otherwise noted)†

Supply voltage range, V_{DD} (see Note 1)	–0.5 V to 4 V
Output voltage range, V_O , at any output terminal	–0.5 V to $V_{DD} + 0.5$ V
Input voltage range, V_I , at any input terminal	–0.5 V to $V_{DD} + 0.5$ V
Continuous total power dissipation	see Dissipation Rating Table
Operating free-air temperature range, T_A	–40°C to 85°C
Storage temperature range, T_{stg}	–65°C to 150°C
Lead temperature 1,6 mm (1/16 inch) from case for 10 seconds	260°C

† Stresses beyond those listed under “absolute maximum ratings” may cause permanent damage to the device. These are stress ratings only, and functional operation of the device at these or any other conditions beyond those indicated under “recommended operating conditions” is not implied. Exposure to absolute-maximum-rated conditions for extended periods may affect device reliability.

NOTE 1: All voltage values are with respect to the GND terminals.

DISSIPATION RATING TABLE

PACKAGE	$T_A \leq 25^\circ\text{C}$ POWER RATING	DERATING FACTOR ABOVE $T_A = 25^\circ\text{C}$ ‡	$T_A = 85^\circ\text{C}$ POWER RATING
DBQ	1400 mW	11 mW/°C	740 mW

‡ This is the inverse of the junction-to-ambient thermal resistance when board-mounted and with no air flow.

recommended operating conditions

	MIN	NOM	MAX	UNIT
Supply voltage, V_{DD} (V_{DDP} , V_{DDPA} , V_{DDO})	3	3.3	3.6	V
High-level input voltage, V_{IH} (CMOS)	$0.7 \times V_{DD}$			V
Low-level input voltage, V_{IL} (CMOS)	$0.3 \times V_{DD}$			V
REFCLK low-level input voltage, V_{IL}	$0.3 \times V_{DDREF}$			V
REFCLK high-level input voltage, V_{IH}	$0.7 \times V_{DDREF}$			V
Input signal low voltage, V_{IL} (STOPB, DLYCTRL, LEADLAG)	$0.3 \times V_{DDPD}$			V
Input signal high voltage, V_{IH} (STOPB, DLYCTRL, LEADLAG)	$0.7 \times V_{DDPD}$			V
Input reference voltage for (REFCLK) (V_{DDREF})	1.235		V_{DD}	V
Input reference voltage for (DLYCTRL and LEADLAG) (V_{DDPD})	1.235		V_{DD}	V
High-level output current, I_{OH}			–16	mA
Low-level output current, I_{OL}			16	mA
Operating free-air temperature, T_A	–40		85	°C

timing requirements

	MIN	MAX	UNIT
Input frequency of modulation, f_{mod} (if driven by SSC CLKIN)		33	kHz
Modulation index (nonlinear maximum 0.5%)		0.6%	
Input slew rate, SR	1	4	V/ns
Input duty cycle on REFCLK	40%	60%	
Input frequency on REFCLK	19	125	MHz
Allowable frequency on DLYCTRL		200	MHz
Allowable frequency on LEADLAG		400	MHz
Allowable duty cycle on DLYCTRL and LEADLAG	25%	75%	



CDC5801A

LOW JITTER CLOCK MULTIPLIER AND DIVIDER WITH PROGRAMMABLE DELAY AND PHASE ALIGNMENT

SCAS813A – AUGUST 2005 – REVISED DECEMBER 2005

electrical characteristics over recommended operating free-air temperature range (unless otherwise noted)

PARAMETER		TEST CONDITIONS†	MIN	TYP‡	MAX	UNIT
$V_{O(STOP)}$	Output voltage during CLK stop mode	See Figure 1	1.1		2	V
V_{OX}	Output crossing-point voltage	See Figure 1 and Figure 4	$0.5V_{DDO}-0.2$		$0.5V_{DDO}+0.2$	V
V_O	Output voltage swing ($V_{OH} - V_{OL}$)	See Figure 1	1.7		2.9	V
V_{IK}	Input clamp voltage	$V_{DD} = 3\text{ V}$, $I_I = -18\text{ mA}$			-1.2	V
V_{OH}	High-level output voltage	See Figure 1, $V_{DD} = 3\text{ to }3.6\text{ V}$	2.0	2.6		V
		$V_{DD} = 3\text{ V}$, $I_{OH} = -16\text{ mA}$	2.2			
V_{OL}	Low-level output voltage	See Figure 1, $V_{DD} = 3\text{ to }3.6\text{ V}$		0.3	0.6	V
		$V_{DD} = 3\text{ V}$, $I_{OL} = 16\text{ mA}$			0.5	
I_{OH}	High-level output current	$V_{DD} = 3.135\text{ V}$, $V_O = 1\text{ V}$	-32	-52		mA
		$V_{DD} = 3.3\text{ V}$, $V_O = 1.65\text{ V}$		-51		
		$V_{DD} = 3.465\text{ V}$, $V_O = 3.135\text{ V}$		-14.5	-21	
I_{OL}	Low-level output current	$V_{DD} = 3.135\text{ V}$, $V_O = 1.95\text{ V}$	43	61.5		mA
		$V_{DD} = 3.3\text{ V}$, $V_O = 1.65\text{ V}$		65		
		$V_{DD} = 3.465\text{ V}$, $V_O = 0.4\text{ V}$		25.5	36	
I_{OZ}	High-impedance-state output current	$P_0 = 0$, $P_1 = 1$			± 10	μA
$I_{OZ(STOP)}$	High-impedance-state output current during CLK stop	Stop = 0, $V_O = \text{GND}$ or V_{DD}			± 100	μA
$I_{OZ(PD)}$	High-impedance-state output current in power-down state	$\text{PWRDNB} = 0$, $V_O = \text{GND}$ or V_{DD}	-10		100	μA
I_{IH}	High-level input current	REFCLK, STOPB $V_{DD} = 3.6\text{ V}$, $V_I = V_{DD}$			10	μA
		PWRDNB, P0:2, MULT/ DIV0:1 $V_{DD} = 3.6\text{ V}$, $V_I = V_{DD}$			10	
I_{IL}	Low-level input current	REFCLK, STOPB $V_{DD} = 3.6\text{ V}$, $V_I = 0$			-10	μA
		PWRDNB, P0:2, MULT/ DIV0:1 $V_{DD} = 3.6\text{ V}$, $V_I = 0$			-10	
Z_O	Output impedance (single ended)	High state R_I at $I_O -14.5\text{ mA}$ to -16.5 mA	15	35	50	Ω
		Low state R_I at $I_O 14.5\text{ mA}$ to 16.5 mA	11	17	35	
	Reference current	V_{DDREF} , V_{DDPD} $V_{DD} = 3.6\text{ V}$	PWRDNB = 0		50	μA
			PWRDNB = 1		0.5	mA
C_I	Input capacitance	$V_I = V_{DD}$ or GND		2		pF
C_O	Output capacitance	$V_O = V_{DD}$ or GND		3		pF
$I_{DD(PD)}$	Supply current in power-down state	REFCLK = 0 MHz to 100 MHz, PWRDNB = 0, STOPB = 1			150	μA
$I_{DD(CLKSTOP)}$	Supply current in CLK stop state	BUSCLK configured for 500 MHz			40	mA
$I_{DD(NORMAL)}$	Supply current in normal state	BUSCLK = 500 MHz P0:2 = 000; load see Figure 1			70	mA

† V_{DD} refers to any of the following; V_{DDPA} , V_{DDPD} , V_{DDREF} , V_{DDO} , and V_{DDP}

‡ All typical values are at $V_{DD} = 3.3\text{ V}$, $T_A = 25^\circ\text{C}$.



CDC5801A
LOW JITTER CLOCK MULTIPLIER AND DIVIDER WITH
PROGRAMMABLE DELAY AND PHASE ALIGNMENT

SCAS813A – AUGUST 2005 – REVISED DECEMBER 2005

jitter specification over recommended operating free-air temperature range and V_{CC} (unless otherwise noted)

PARAMETER	CLKOUT	TEST CONDITIONS	MIN	TYP†	MAX	UNIT
t_{jitter} (Multiplication only mode. Phase alignment and programmable delay features are not selected (PA bypass). See Figure 2.)	155 MHz	Period RMS (1σ jitter, full frequency band)		6		ps
		Period p-p		40		
		Phase jitter (accumulated, 12 kHz to 20 MHz)		50		
		Cycle-to-cycle (+)		27		
		Cycle-to-cycle (-)		27		
200 MHz	Period RMS (1σ jitter, full frequency band)		5.5		ps	
	Period p-p		36			
	Phase jitter (accumulated, 12 kHz to 20 MHz)		36			
	Phase jitter (accumulated, 50 kHz to 80 MHz)		36			
	Cycle-to-cycle (+)		23			
312 MHz	Period RMS (1σ jitter, full frequency band)		3		ps	
	Period p-p		20			
	Phase jitter (accumulated, 12 kHz to 20 MHz)		18			
	Phase jitter (accumulated, 50 kHz to 80 MHz)		18			
	Cycle-to-cycle (+)		17			
400 MHz	Period RMS (1σ jitter, full frequency band)		2.3		ps	
	Period p-p		17			
	Phase jitter (accumulated, 12 kHz to 20 MHz)		12			
	Phase jitter (accumulated, 50 kHz to 80 MHz)		12			
	Cycle-to-cycle (+)		15			
500 MHz	Period RMS (1σ jitter, full frequency band)		2.1		ps	
	Period p-p		16			
	Phase jitter (accumulated, 12 kHz to 20 MHz)		8			
	Phase jitter (accumulated, 50 kHz to 80 MHz)		8			
	Cycle-to-cycle (+)		14			
t_{jitter} (Multiplication with phase alignment and programmable delay features selected. See Figure 2.)	155 MHz	Period RMS (1σ jitter, full frequency band)		9		ps
		Period p-p		70		
		Phase jitter (accumulated, 12 kHz to 20 MHz)		50		
		Cycle-to-cycle (+)		50		
		Cycle-to-cycle (-)		50		
200 MHz	Period RMS (1σ jitter, full frequency band)		7		ps	
	Period p-p		55			
	Phase jitter (accumulated, 12 kHz to 20 MHz)		36			
	Phase jitter (accumulated, 50 kHz to 80 MHz)		36			
	Cycle-to-cycle (+)		40			
312 MHz	Period RMS (1σ jitter, full frequency band)		4		ps	
	Period p-p		35			
	Phase jitter (accumulated, 12 kHz to 20 MHz)		18			
	Phase jitter (accumulated, 50 kHz to 80 MHz)		18			
	Cycle-to-cycle (+)		30			
400 MHz	Period RMS (1σ jitter, full frequency band)		3.1		ps	
	Period p-p		27			
	Phase jitter (accumulated, 12 kHz to 20 MHz)		13			
	Phase jitter (accumulated, 50 kHz to 80 MHz)		13			
	Cycle-to-cycle (+)		25			
		Cycle-to-cycle (-)		25		

† All typical values are at $V_{DD} = 3.3$ V, $T_A = 25^\circ\text{C}$.



LOW JITTER CLOCK MULTIPLIER AND DIVIDER WITH PROGRAMMABLE DELAY AND PHASE ALIGNMENT

SCAS813A – AUGUST 2005 – REVISED DECEMBER 2005

jitter specification over recommended operating free-air temperature range and V_{CC} (unless otherwise noted) (continued)

PARAMETER		CLKOUT	TEST CONDITIONS	MIN	TYP†	MAX	UNIT		
t(jitter) (Multiplication with phase alignment and programmable delay features selected. See Figure 2.)		500 MHz	Period RMS (1σ jitter, full frequency band)		2.9		ps		
			Period p-p		24				
			Phase jitter (accumulated, 12 kHz to 20 MHz)		9				
			Phase jitter (accumulated, 50 kHz to 80 MHz)		9				
			Cycle-to-cycle (+)		20				
			Cycle-to-cycle (-)		20				
t(jitter) (Divider mode with phase aligner not active: DLYCTRL = LEADLAG = 0 or 1. See Figure 2.)	MULT0:1 = 11 (Divider ratio = 4)	12.5 MHz	Period RMS (1σ jitter, full frequency band)		12		ps		
			Period p-p		75				
			Cycle-to-cycle (+)		55				
			Cycle-to-cycle (-)		55				
			15.5 MHz	Period RMS (1σ jitter, full frequency band)		8		ps	
				Period p-p		50			
				Cycle-to-cycle (+)		38			
				Cycle-to-cycle (-)		38			
		MULT0:1 = 10 (Divider ratio = 3)	25 MHz	Period RMS (1σ jitter, full frequency band)		7.5		ps	
					Period p-p		50		
					Cycle-to-cycle (+)		35		
					Cycle-to-cycle (-)		35		
		31 MHz	Period RMS (1σ jitter, full frequency band)		5.5		ps		
			Period p-p		30				
			Cycle-to-cycle (+)		23				
			Cycle-to-cycle (-)		23				
	MULT0:1 = 00 (Divider ratio = 2)	50 MHz	Period RMS (1σ jitter, full frequency band)		8		ps		
				Period p-p		40			
				Phase jitter (accumulated, 12 kHz to 20 MHz)		12			
				Cycle-to-cycle (+)		30			
		62.5 MHz	Period RMS (1σ jitter, full frequency band)		5.5		ps		
			Period p-p		28				
			Phase jitter (accumulated, 12 kHz to 20 MHz)		9				
			Cycle-to-cycle (+)		24				
			Cycle-to-cycle (-)		24				
t(jitter) (Divider mode with phase alignment and programmable delay features selected. See Figure 2.)	MULT0:1 = 11 (Divider ratio = 4)	12.5 MHz	Period RMS (1σ jitter, full frequency band)		12.5		ps		
					Period p-p			80	
					Cycle-to-cycle (+)			55	
					Cycle-to-cycle (-)			55	
			15.5 MHz	Period RMS (1σ jitter, full frequency band)		8.5		ps	
				Period p-p		55			
				Cycle-to-cycle (+)		38			
				Cycle-to-cycle (-)		38			
	MULT0:1 = 10 (Divider ratio = 3)	25 MHz	Period RMS (1σ jitter, full frequency band)		10		ps		
				Period p-p		60			
				Cycle-to-cycle (+)		35			
				Cycle-to-cycle (-)		35			
		31 MHz	Period RMS (1σ jitter, full frequency band)		7		ps		
			Period p-p		40				
			Cycle-to-cycle (+)		23				
			Cycle-to-cycle (-)		23				

CDC5801A
LOW JITTER CLOCK MULTIPLIER AND DIVIDER WITH
PROGRAMMABLE DELAY AND PHASE ALIGNMENT

SCAS813A – AUGUST 2005 – REVISED DECEMBER 2005

jitter specification over recommended operating free-air temperature range and V_{CC} (unless otherwise noted) (continued)

PARAMETER		CLKOUT	TEST CONDITIONS	MIN	TYP†	MAX	UNIT
t_{jitter} (Divider mode with phase alignment and programmable delay features selected. See Figure 2.)	MULT0:1 = 00 (Divider ratio = 2)	50 MHz	Period RMS (1σ jitter, full frequency band)		9		ps
			Period p-p		50		
			Phase jitter (accumulated, 12 kHz to 20 MHz)		13		
			Cycle-to-cycle (+)		35		
			Cycle-to-cycle (-)		35		
		62.5 MHz	Period RMS (1σ jitter, full frequency band)		6.5		ps
			Period p-p		30		
			Phase jitter (accumulated, 12 kHz to 20 MHz)		10		
			Cycle-to-cycle (+)		26		
			Cycle-to-cycle (-)		26		

† All typical values are at $V_{DD} = 3.3\text{ V}$, $T_A = 25^\circ\text{C}$.

switching characteristics over recommended operating free-air temperature range (unless otherwise noted)

PARAMETER		TEST CONDITIONS	MIN	TYP†	MAX	UNIT
t_{DC}	Output duty cycle	See Figure 3	45%		55%	
t_r , t_f	Output rise and fall times (measured at 20%–80% of output voltage)	See Figure 5 and Figure 1	150		350	ps

† All typical values are at $V_{DD} = 3.3\text{ V}$, $T_A = 25^\circ\text{C}$.

CDC5801A

LOW JITTER CLOCK MULTIPLIER AND DIVIDER WITH PROGRAMMABLE DELAY AND PHASE ALIGNMENT

SCAS813A – AUGUST 2005 – REVISED DECEMBER 2005

state transition latency specifications

PARAMETER		FROM	TO	TEST CONDITIONS	MIN	TYP†	MAX	UNIT
t(powerup)	Delay time, PWRDNB↑ to CLKOUT/CLKOUTB output settled (excluding t(DISTLOCK))	Powerdown	Normal	See Figure 6			3	ms
	Delay time, PWRDNB↑ to internal PLL and clock are on and settled						3	
t(VDDpowerup)	Delay time, power up to CLKOUT/CLKOUTB output settled	VDD	Normal	See Figure 6			3	ms
	Delay time, power up to internal PLL and clock are on and settled						3	
t(MULT)	MULT0 and MULT1 change to CLKOUT/CLKOUTB output resettled (excluding t(DISTLOCK))	Normal	Normal	See Figure 7			1	ms
t(CLKON)	STOPB↑ to CLKOUT/CLKOUTB glitch-free clock edges	CLK Stop	Normal	See Figure 8			10	ns
t(CLKSETL)	STOPB↑ to CLKOUT/CLKOUTB output settled to within 50 ps of the phase before STOPB was disabled	CLK Stop	Normal	See Figure 8			20	cycles
t(CLKOFF)	STOPB↓ to CLKOUT/CLKOUTB output disabled	Normal	CLK Stop	See Figure 8			5	ns
t(powerdown)	Delay time, PWRDNB↓ to the device in the power-down mode	Normal	Power-down	See Figure 6			1	ms
t(STOP)	Maximum time in CLKSTOP (STOPB = 0) before reentering normal mode (STOPB = 1)	STOPB	Normal	See Figure 8			100	μs
t(ON)	Minimum time in normal mode (STOPB = 1) before reentering CLKSTOP (STOPB = 0)	Normal	CLK stop	See Figure 8	100			ms

† All typical values are at V_{DD} = 3.3 V, T_A = 25°C.

PARAMETER MEASUREMENT INFORMATION

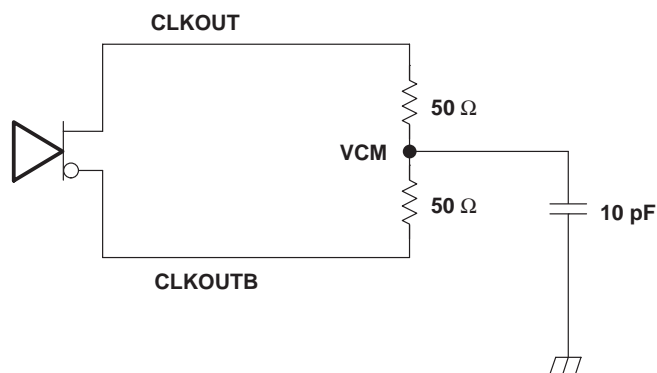

Figure 1. Test Load and Voltage Definitions (V_{O(STOP)}, V_{OX}, V_{OH}, V_{OL})

PARAMETER MEASUREMENT INFORMATION

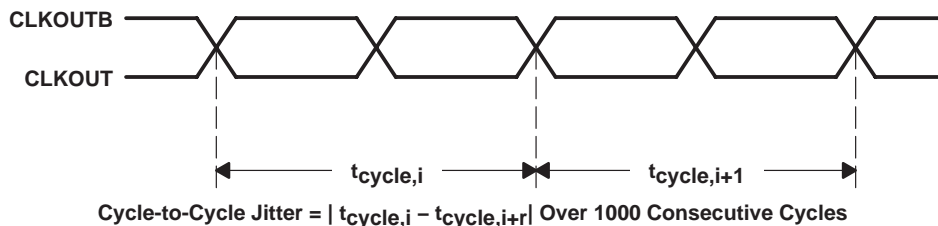

Figure 2. Cycle-to-Cycle Jitter

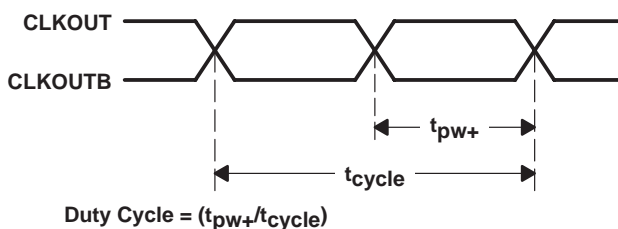

Figure 3. Output Duty Cycle

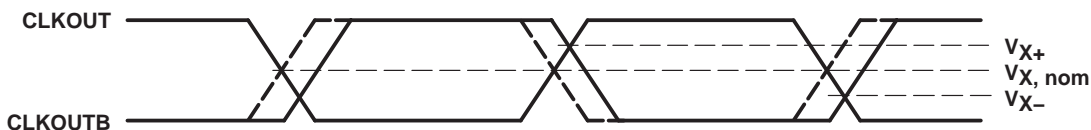

Figure 4. Crossing-Point Voltage



Figure 5. Voltage Waveforms

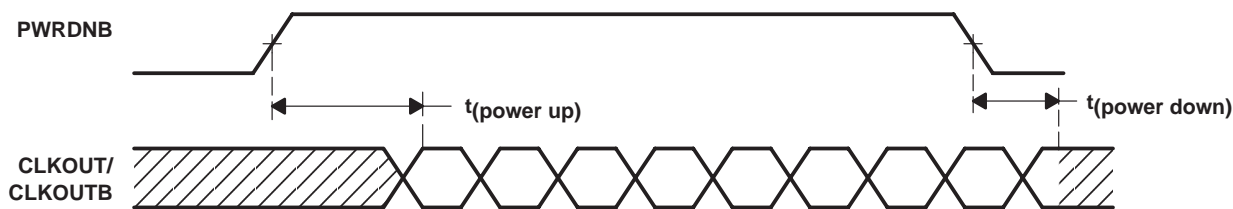

Figure 6. PWRDNB Transition Timings

CDC5801A
LOW JITTER CLOCK MULTIPLIER AND DIVIDER WITH
PROGRAMMABLE DELAY AND PHASE ALIGNMENT

SCAS813A – AUGUST 2005 – REVISED DECEMBER 2005

PARAMETER MEASUREMENT INFORMATION

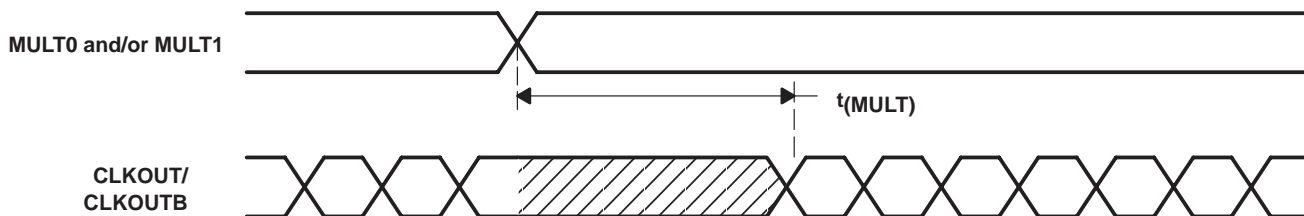
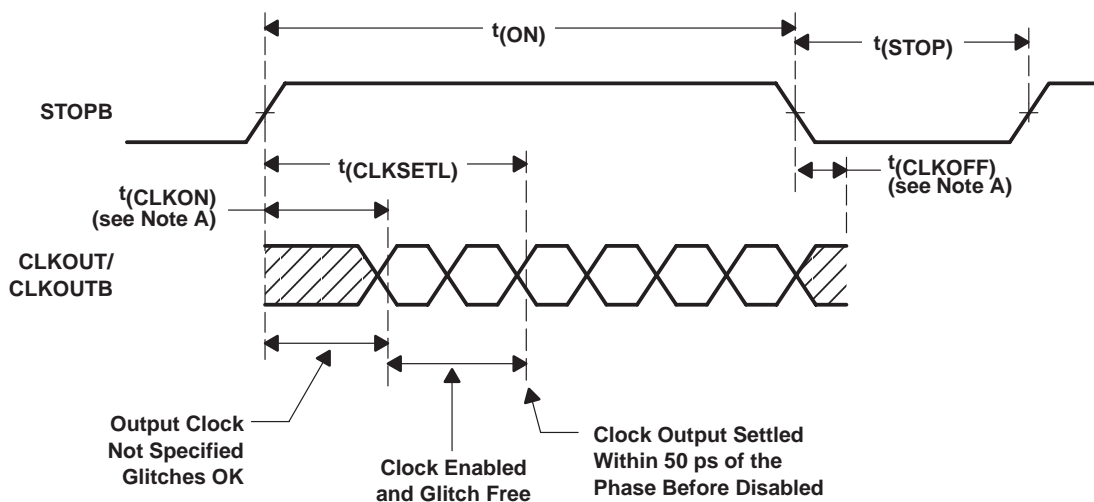

Figure 7. MULT Transition Timings



NOTE A: $V_{ref} = V_O \pm 200 \text{ mV}$

Figure 8. STOPB Transition Timings

CDC5801A LOW JITTER CLOCK MULTIPLIER AND DIVIDER WITH PROGRAMMABLE DELAY AND PHASE ALIGNMENT

SCAS813A – AUGUST 2005 – REVISED DECEMBER 2005

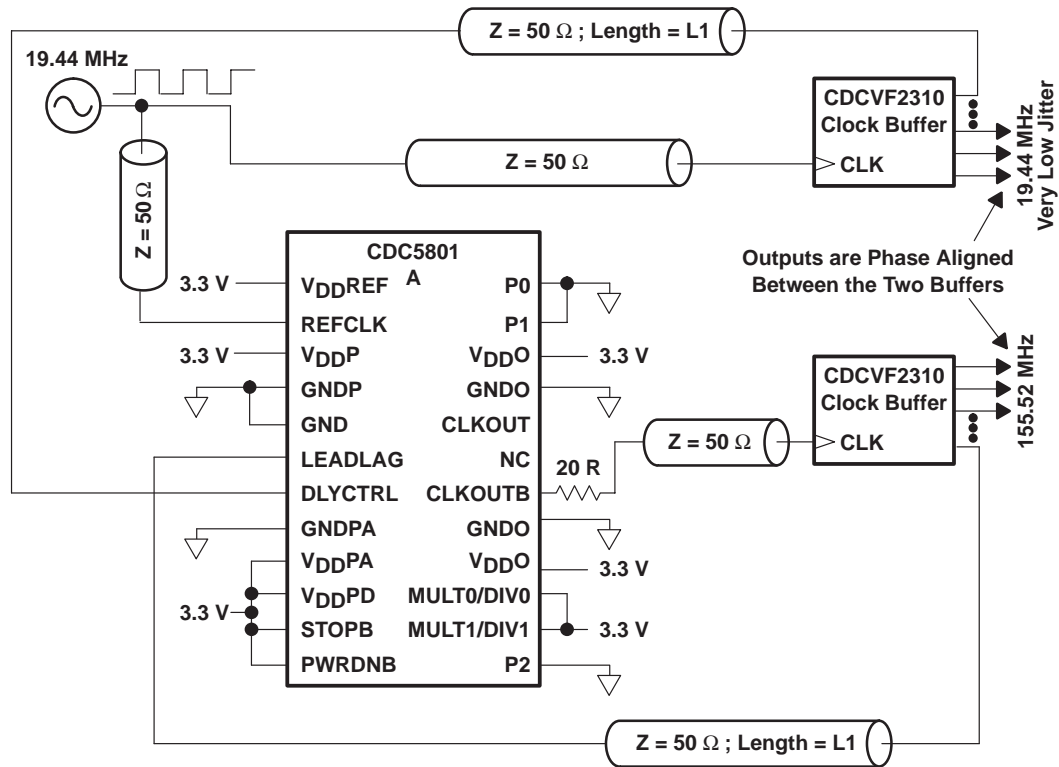

Figure 9. Using the CDC5801A Device as a Multiplier by 8 and Aligning Two Different Clocks

CDC5801A
LOW JITTER CLOCK MULTIPLIER AND DIVIDER WITH
PROGRAMMABLE DELAY AND PHASE ALIGNMENT

SCAS813A – AUGUST 2005 – REVISED DECEMBER 2005

MECHANICAL DATA

DBQ (R-PDSO-G)**

PLASTIC SMALL-OUTLINE PACKAGE

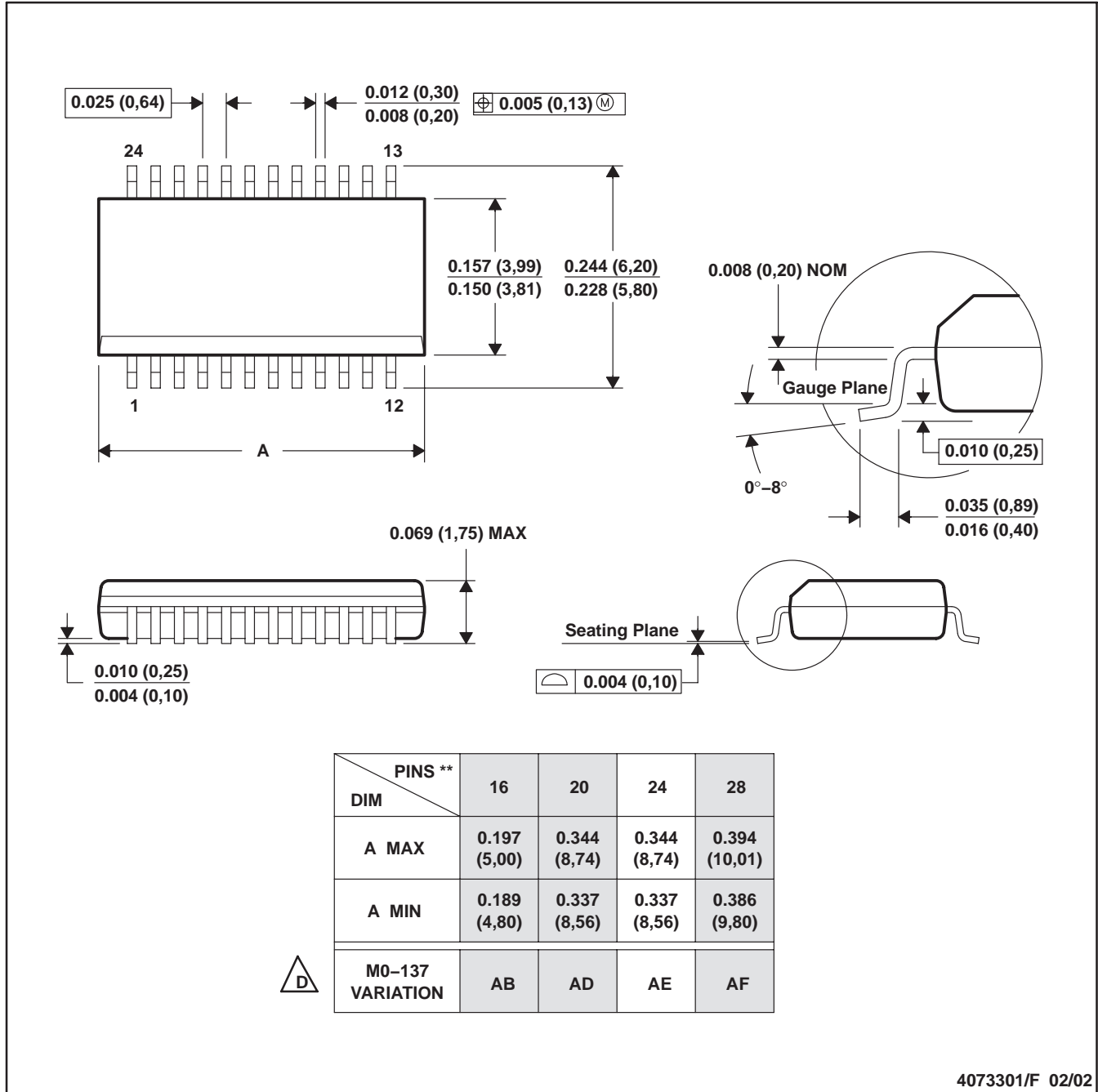

4073301/F 02/02

- NOTES: A. All linear dimensions are in millimeters.
 B. This drawing is subject to change without notice.
 C. Body dimensions do not include mold flash or protrusion not to exceed 0.006 (0,15).
 D. Falls within JEDEC MO-137.

TAPE AND REEL INFORMATION



QUADRANT ASSIGNMENTS FOR PIN 1 ORIENTATION IN TAPE



*All dimensions are nominal

Device	Package Type	Package Drawing	Pins	SPQ	Reel Diameter (mm)	Reel Width W1 (mm)	A0 (mm)	B0 (mm)	K0 (mm)	P1 (mm)	W (mm)	Pin1 Quadrant
CDC5801ADBQR	SSOP/QSOP	DBQ	24	2500	330.0	16.4	6.5	9.0	2.1	8.0	16.0	Q1

TAPE AND REEL BOX DIMENSIONS



*All dimensions are nominal

Device	Package Type	Package Drawing	Pins	SPQ	Length (mm)	Width (mm)	Height (mm)
CDC5801ADBQR	SSOP/QSOP	DBQ	24	2500	346.0	346.0	33.0

IMPORTANT NOTICE

Texas Instruments Incorporated and its subsidiaries (TI) reserve the right to make corrections, modifications, enhancements, improvements, and other changes to its products and services at any time and to discontinue any product or service without notice. Customers should obtain the latest relevant information before placing orders and should verify that such information is current and complete. All products are sold subject to TI's terms and conditions of sale supplied at the time of order acknowledgment.

TI warrants performance of its hardware products to the specifications applicable at the time of sale in accordance with TI's standard warranty. Testing and other quality control techniques are used to the extent TI deems necessary to support this warranty. Except where mandated by government requirements, testing of all parameters of each product is not necessarily performed.

TI assumes no liability for applications assistance or customer product design. Customers are responsible for their products and applications using TI components. To minimize the risks associated with customer products and applications, customers should provide adequate design and operating safeguards.

TI does not warrant or represent that any license, either express or implied, is granted under any TI patent right, copyright, mask work right, or other TI intellectual property right relating to any combination, machine, or process in which TI products or services are used. Information published by TI regarding third-party products or services does not constitute a license from TI to use such products or services or a warranty or endorsement thereof. Use of such information may require a license from a third party under the patents or other intellectual property of the third party, or a license from TI under the patents or other intellectual property of TI.

Reproduction of TI information in TI data books or data sheets is permissible only if reproduction is without alteration and is accompanied by all associated warranties, conditions, limitations, and notices. Reproduction of this information with alteration is an unfair and deceptive business practice. TI is not responsible or liable for such altered documentation. Information of third parties may be subject to additional restrictions.

Resale of TI products or services with statements different from or beyond the parameters stated by TI for that product or service voids all express and any implied warranties for the associated TI product or service and is an unfair and deceptive business practice. TI is not responsible or liable for any such statements.

TI products are not authorized for use in safety-critical applications (such as life support) where a failure of the TI product would reasonably be expected to cause severe personal injury or death, unless officers of the parties have executed an agreement specifically governing such use. Buyers represent that they have all necessary expertise in the safety and regulatory ramifications of their applications, and acknowledge and agree that they are solely responsible for all legal, regulatory and safety-related requirements concerning their products and any use of TI products in such safety-critical applications, notwithstanding any applications-related information or support that may be provided by TI. Further, Buyers must fully indemnify TI and its representatives against any damages arising out of the use of TI products in such safety-critical applications.

TI products are neither designed nor intended for use in military/aerospace applications or environments unless the TI products are specifically designated by TI as military-grade or "enhanced plastic." Only products designated by TI as military-grade meet military specifications. Buyers acknowledge and agree that any such use of TI products which TI has not designated as military-grade is solely at the Buyer's risk, and that they are solely responsible for compliance with all legal and regulatory requirements in connection with such use.

TI products are neither designed nor intended for use in automotive applications or environments unless the specific TI products are designated by TI as compliant with ISO/TS 16949 requirements. Buyers acknowledge and agree that, if they use any non-designated products in automotive applications, TI will not be responsible for any failure to meet such requirements.

Following are URLs where you can obtain information on other Texas Instruments products and application solutions:

Products

Amplifiers	amplifier.ti.com
Data Converters	dataconverter.ti.com
DSP	dsp.ti.com
Clocks and Timers	www.ti.com/clocks
Interface	interface.ti.com
Logic	logic.ti.com
Power Mgmt	power.ti.com
Microcontrollers	microcontroller.ti.com
RFID	www.ti-rfid.com
RF/IF and ZigBee® Solutions	www.ti.com/lprf

Applications

Audio	www.ti.com/audio
Automotive	www.ti.com/automotive
Broadband	www.ti.com/broadband
Digital Control	www.ti.com/digitalcontrol
Medical	www.ti.com/medical
Military	www.ti.com/military
Optical Networking	www.ti.com/opticalnetwork
Security	www.ti.com/security
Telephony	www.ti.com/telephony
Video & Imaging	www.ti.com/video
Wireless	www.ti.com/wireless

Mailing Address: Texas Instruments, Post Office Box 655303, Dallas, Texas 75265
Copyright © 2008, Texas Instruments Incorporated