

PART NO.	"A" ±.020 (±0.4)	"B" REF.	"C" REF.	MATERIAL (COLOR)
CFCC-3-05A-RT	9/16 (14.3)	.49 (12.4)	.18 (4.6)	NORYL, RMS-05 (WHITE)
CFCC-4-05A-RT	9/16 (14.3)	.40 (10.2)	.25 (6.4)	
CFCC-8-05A-RT	1-1/16 (27.0)	.88 (22.3)	.25 (6.4)	
CFCC-8-04A-RT	1-1/16 (27.0)	.88 (22.3)	.25 (6.4)	RIGID PVC, RMS-04 (GREY)

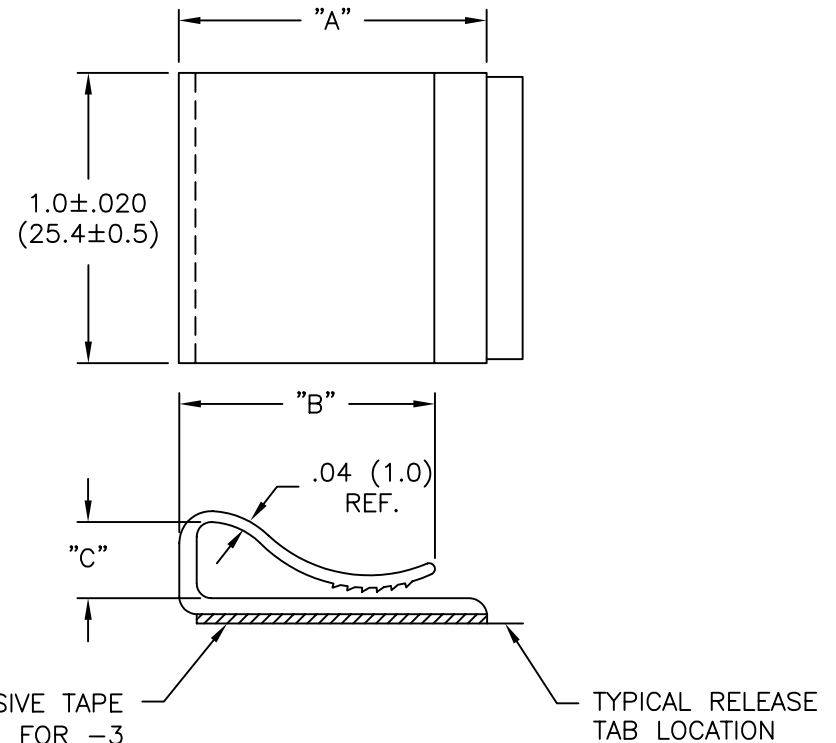

NOTES:

1. ACRYLIC ADHESIVE TAPE (RMS-15), WHITE LINER.
2. RUBBER ADHESIVE TAPE (RMS-102), BLUE LINER, AVAILABLE BY SPECIAL ORDER ONLY.
TO ORDER, REPLACE "A-RT" WITH "A1-RT" ON PART NO.
3. CUSTOM LENGTHS AVAILABLE BY SPECIAL ORDER.

DOUBLE SIDED ADHESIVE TAPE
1/32 (0.8) THICK FOR -3
1/16 (1.6) THICK FOR -4 & -8

J	ADDED RUBBER ADHESIVE BY SPECIAL ORDER	SM 09.11.02
I	ADDED NOTE 1 & CORRECTED METRIC DIM.	SJ 3.13.02
H	CORRECTED TAPE NOTE	SM 12.13.01
G	ADDED RMS-05 AND RMS-04 TO MATERIAL	SM 12.11.01
F	CHANGED FILE NO. AND TITLE BLOCK	SM 07.20.01
E	ADDED ±.020 TOL. A DIM	JK 9.1.99
D	CONVERTED TO ACAD	PB 06.21.95
C	ADD MAT'L, COLOR	RS 10.29.92
B	ADDED PART NO. CFCC-8-04A-RT ADD SUFFIX "A" IN ALL P/N'S	RS 06.22.92
A	ADDED CFCC-3 TO CHART	AH 03.07.90
REV	DESCRIPTION	ENGR DATE

TITLE: CONTINUOUS FLAT CABLE CLAMPS				DWG IN IN (MM)	FINAL	PRINT TYPE CA
TOLERANCES UNLESS NOTED .XX=±.010 .XXX=±.015 FRAC=±1/64 ANG=±1'	FILE # CFCC	DWN: P.B.	APP:	PART # SEE TABLE	PRINT TYPE CA	
	MAT'L: SEE TABLE	DT: 06-21-94	DT:			
	RE: RICHCO, INC.	RICHCO INC. PO BOX 804238, CHICAGO, 60680 (773) 539-4060				