



CHRONTEL

CH7203

MPEG to TV Encoder with 16-bit Input

Features

- Outputs to NTSC, PAL (B, D, G, H, I) and PAL-60
- 16-bit YCrCb (4:2:2) input format
- Simultaneous composite/S-video outputs
- Triple 9-bit video DACs
- 27 MHz DAC operating frequency eliminates the need for 1/sinc(x) correction filter
- Low-jitter phase-locked loop circuitry operates using a low-cost 14.31818 MHz crystal
- 40.5 or 33.9 MHz video decoder clock output
- 16.934 or 11.289 MHz audio decoder clock output
- 13.5 MHz and 27 MHz video pixel clock outputs
- Optimized luminance and chrominance internal filters for NTSC and PAL
- HSYNC* and VSYNC* outputs for master mode operation
- Sleep mode
- CMOS technology in 44-pin PLCC
- 5V single-supply operation

Description

The CH7203 video encoder integrates a dual PLL clock generator and a digital NTSC/PAL video encoder. By generating all essential clock signals for MPEG playback, and converting digital video inputs to either NTSC or PAL video signals, the CH7203 is an essential component of any low-cost solution for video-CD playback machines.

The CH7203 dual PLL clock synthesizer generates all clocks and timing signals from a 14.31818 MHz reference crystal (see application note 19 "Tuning Clock Outputs" for selection and tuning of the 14.31818 MHz crystal). The CH7203 generates a 40.5 or 33.9 MHz video decoder clock, 13.5 MHz and 27 MHz video pixel clocks, and a 16.934 or 11.289 MHz audio decoder clock. Timing signals from the PLLs are used to generate the horizontal and vertical sync signals which enable operating the CH7203 in master mode.

The fully digital video encoder is pin-programmable to generate either a 525-line NTSC or a 625-line PAL compatible video signal. It also features a logic selectable sleep mode which turns the encoder off while leaving both PLL's running.

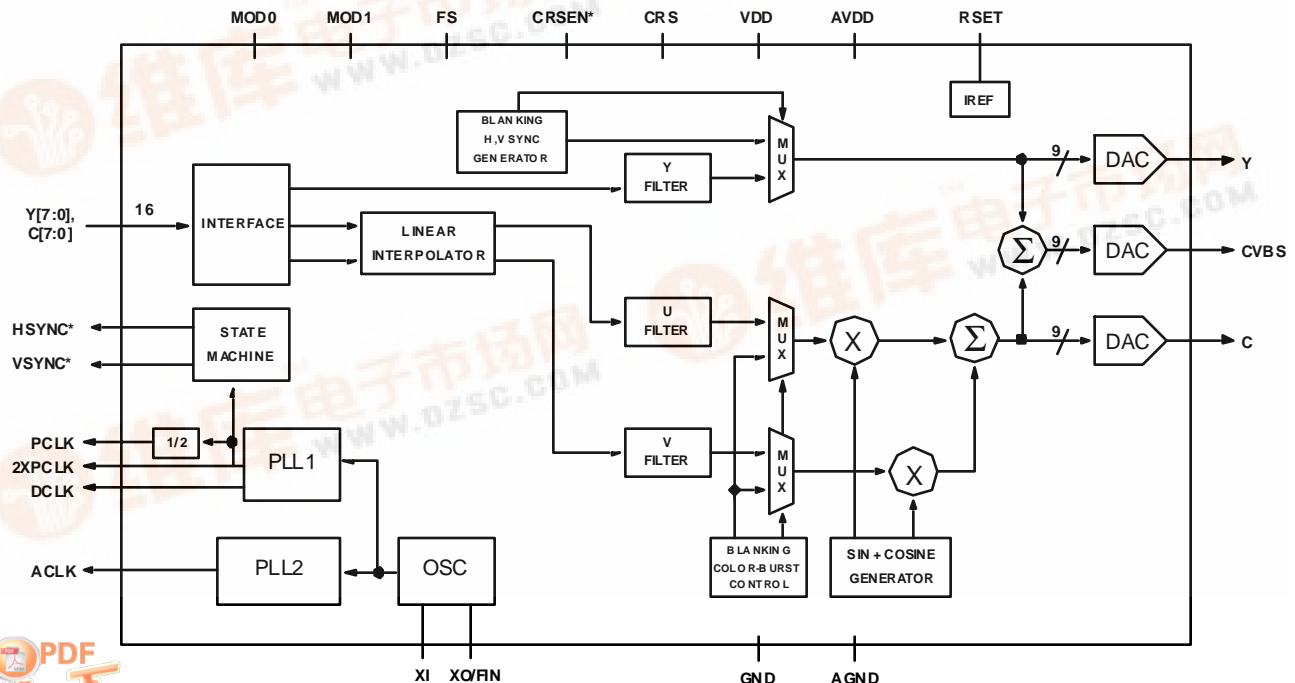

Figure 1: Functional Block Diagram



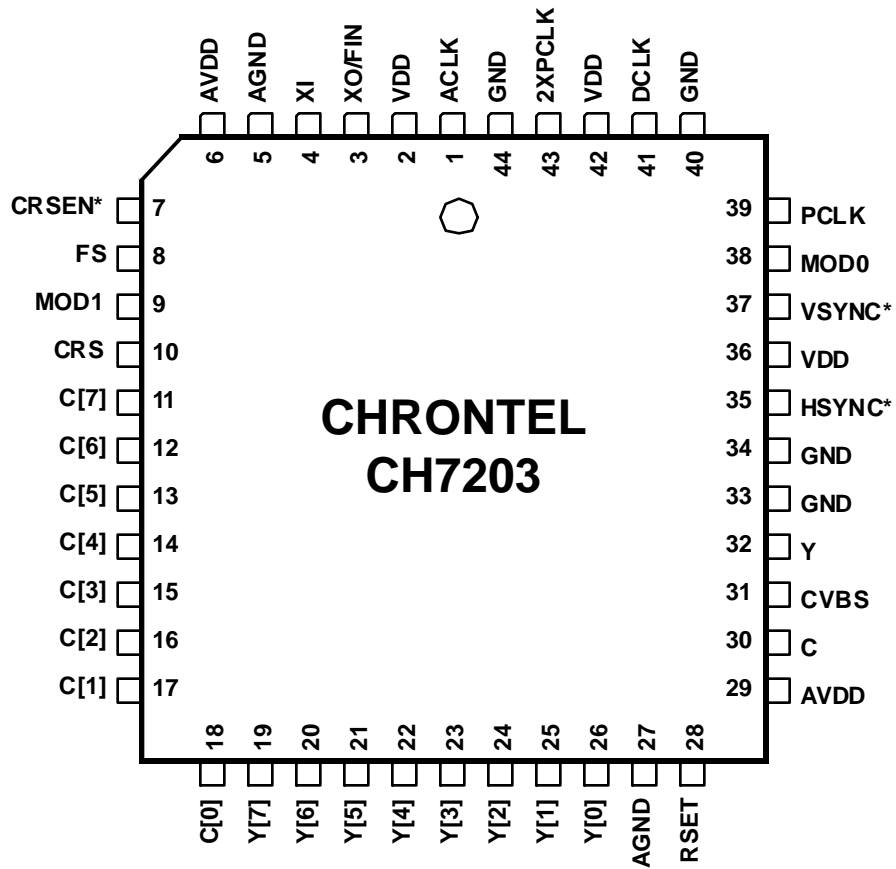

Figure 2: CH7203 Pinout Diagram

Table 1. Pin Descriptions

Pin	Type	Symbol	Description
1	Out	ACLK	Audio Decoder Clock Output 16.934 MHz or 11.289 MHz clock output (selectable by FS) for MPEG audio decoder operation. The output swing is 5V.
2, 36, 42	Power	VDD	Digital Supply Voltage These pins supply the 5V power to the digital section of the CH7203.
3	In	XO/FIN	Crystal Output or External F_{REF} Input¹ A 14.31818 MHz (± 50 ppm) parallel resonance crystal may be attached between XO/FIN and XI. An external CMOS compatible clock can be connected to XO/FIN as an alternative.
4	In	XI	Crystal Input¹ A 14.31818 MHz (± 50 ppm) parallel resonance crystal should be attached between XI and XO/FIN. However, if an external CMOS clock is attached to XO/FIN, XI should be connected to ground.
5, 27	Power	AGND	Analog ground These pins provide the ground reference for the analog section of the CH7203. These pins MUST be connected to the system ground to prevent latchup.
6,29	Power	AVDD	Analog Supply Voltage These pins supply the 5V power to the analog section of the CH7203.
7	In	CRSEN*	Cr Select Enable. Internally pulled-up. CRSEN*=0, Cr, Cb data sequence is specified by the CRS pin. CRSEN*=1, Cr, Cb data sequence is specified by the CH7203's internal default condition: Horizontal count = even, data is Cb; data is Cr otherwise. State of CRS is ignored when CRSEN*=1. See Figure 6 on page 7.
8	In	FS	Frequency Select. Internally pulled-up FS = 1 (default), then DCLK = 40.5 MHz, ACLK = 16.934 MHz FS = 0, then DCLK = 33.9 MHz, ACLK = 11.289 MHz
9	In	MOD1	Mode bit 1 - Internally pulled-up This input works in conjunction with the MOD0 input to select NTSC, PAL, or Sleep mode functions. Refer to Table 3, "Video Encoder Modes," on page 6 for details.
10	In	CRS	Cr Select. When CRSEN*=0, CRS specifies the CrCb data sequence. CRS is an alternating signal. CRS=1 indicates that C[7:0] carry the Cr data. C[7:0] carry the Cb data otherwise. See Figure 7 on page 8.
11 – 18	In	C[7:0]	Video Input These pins accept the "CrCb" data of the YCrCb (4:2:2) digital video format. The Cb & Cr data appear alternately. The sequence of the Cb, Cr data is either predefined by the internal horizontal counter (even = Cb, odd = Cr) or as specified by pin CRS (data is Cr for CRS=1 and Cb otherwise. For more details, please refer to the timing diagram shown in Figure 6 on page 7. Cb & Cr have a nominal range of 16–240, with 128 equal to zero.

Note: 1. Please refer to crystal manufacturer specifications for proper load capacitances. The optional variable tuning capacitor is required only if the crystal oscillation frequency cannot be controlled to the required accuracy. The capacitance value for the tuning capacitor should be obtained from the crystal manufacturer. For further information, request a copy of **Application Note AN-19, "Tuning Clock Outputs."**

Table 2. Pin Descriptions (continued)

Pin	Type	Symbol	Description
19-26	In	Y[7:0]	Video Input These pins accept the “Y” data of the YCrCb (4:2:2) digital video format. For more details, please refer to the timing diagram shown in Figure 7 on page 8. Y has a nominal range of 16-235.
28	In	RSET	Reference Resistor A 360 Ω resistor with short and wide traces should be attached between RSET and ground. No other connections should be made to this pin.
30	Out	C	Chrominance Output A 75 Ω termination resistor with short traces should be attached between C and ground for optimum performance.
31	Out	CVBS	Composite Output A 75 Ω termination resistor with short traces should be attached between CVBS and ground for optimum performance.
32	Out	Y	Luminance Output A 75 Ω termination resistor with short traces should be attached between Y and ground for optimum performance.
33, 34, 40, 44	Power	GND	Digital Ground These pins provide the ground reference for the digital section of the CH7203. These pins MUST be connected to the system ground through independent ground vias.
35	Out	HSYNC*	Horizontal Sync Output The horizontal sync output is generated by the CH7203 for master mode operation. HSYNC* is an active low signal with a 5V output swing. For additional information, please refer to the timing diagrams shown in Figures 5 and 6 on page 7.
37	Out	VSYNC*	Vertical Sync Output The vertical sync output is generated by the CH7203 for master mode operation. VSYNC* is an active low signal with a 5V output swing. For additional information, please refer to the timing diagrams shown in Figures 5 and 7 on page 7 and 8.
38	In	MOD0	Mode bit 0 - internally pulled-up This input works in conjunction with the MOD1 input to select NTSC, PAL, or Sleep Mode functions. Refer to Table 3, “Video Encoder Modes,” on page 6 for details.
39	Out	PCLK	Video Pixel Clock Output 13.5 MHz clock output. The output swing is 5V.
41	Out	DCLK	MPEG Decoder Clock Output 40.5 MHz or 33.9 MHz clock output (selectable by FS). The output swing is 5V.
43	Out	2XPCLK	Double Pixel Clock Output 27 MHz clock output. The output swing is 5V.

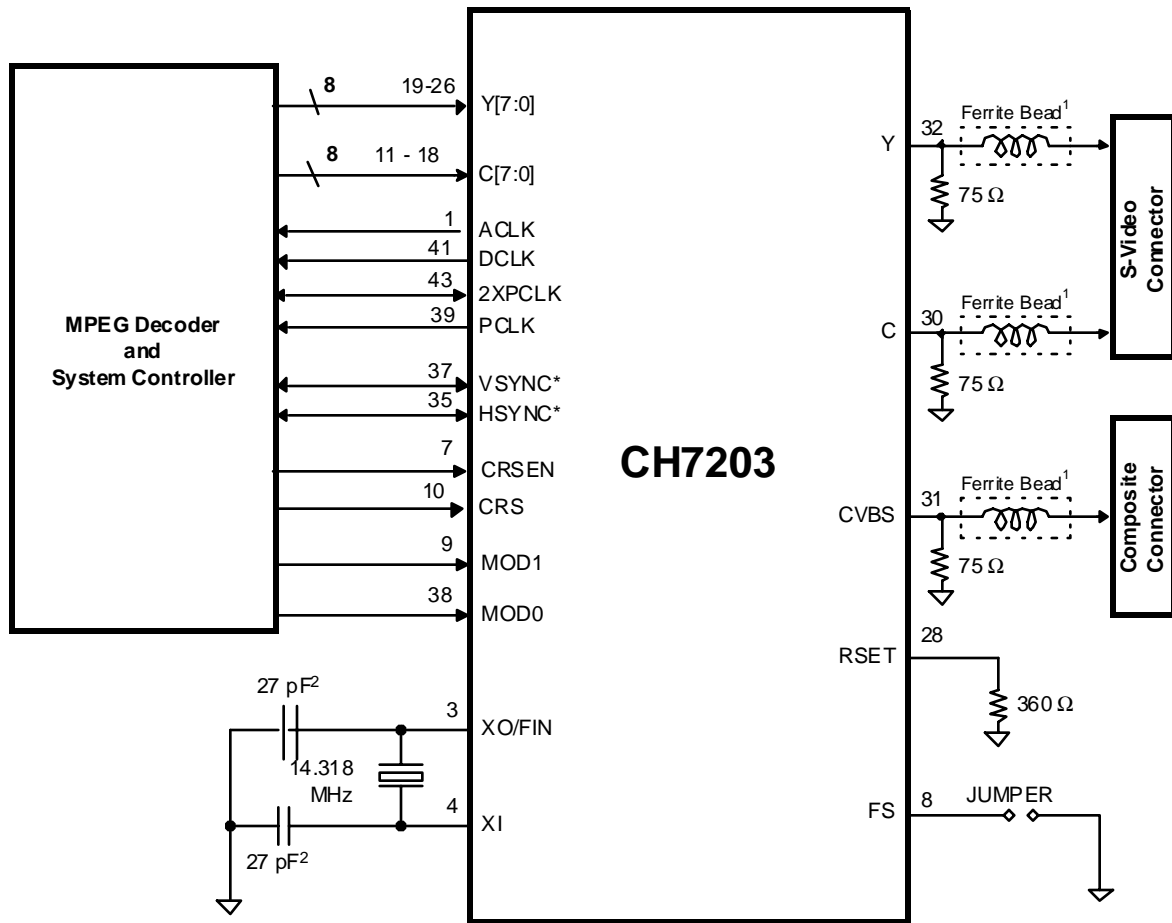

Figure 3: CH7203 Interface Diagram

- Note:**
1. Please refer to the Optional Output Filter diagram below
 2. The proper value of these capacitors depends on the crystal manufacturer's specifications. Please refer to AN06 for the details of the calculation.

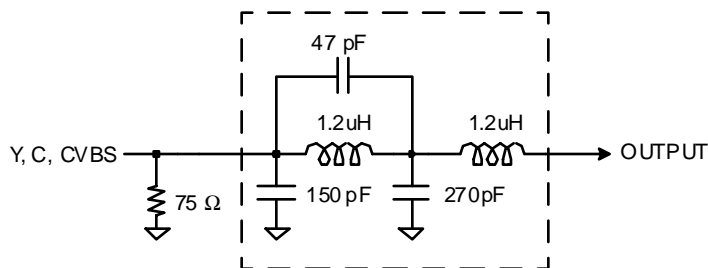

Figure 4: Optional Output Filter

General Description

The CH7203 is a fully integrated solution for converting 16-bit YCrCb (4:2:2) digital video inputs into high-quality NTSC or PAL video signals while generating all essential clock signals for MPEG playback. All essential circuitry for this conversion and clock generation (Dual PLL's, linear interpolator, digital filters, NTSC/PAL encoder, DAC's) are contained in the CH7203 making it an essential component of any low-cost solution for video-CD playback machines. Refer to the Block Diagram on page 1 and the Interface Diagram on page 5.

Functional Description

The encoded luminance (Y) and color-difference (U,V) are interpolated, and filtered through digital filters to minimize aliasing problems. The filtered signals go to the digital encoder where they are transformed to composite and S-video outputs, and then they are converted by the three 9-bit DACs to analog outputs.

16-bit YCrCb (4:2:2) Input

Y data is input through the Y[7:0] inputs and CrCb data is multiplexed through the C[7:0] inputs. When CRSEN* = 1, the Cr Select input, CRS, is ignored, and all even horizontal pixels are Cb data and all odd horizontal pixels are Cr. Refer to **Figure 6** on page 7 for the definition of “even” and “odd” pixels. When CRSEN* = 0, the alternating CRS signal specifies the CrCb sequence. CRS = 1 indicates C[7:0] carries Cr data, and CRS = 0 indicates C[7:0] carries Cb data.

Clock/Data/Synchronization Timing

The CH7203 not only works as an NTSC/PAL encoder, it also supplies the necessary clocks (1X pixel, 2X pixel, video system, and audio) and synchronization (HSYNC* and VSYNC*) signals to other building blocks in the video system. For this reason, the CH7203 works **only** in the Master mode.

It is important to note the CH7203 does not have a “pixel clock” input pin. Therefore, the timing issues related to video pixel data being supplied from, for example, the MPEG decoder, to the CH7203 (pins Y[7:0] and C[7:0]) need to be clarified. Assume the pixel synchronization of a system is based on the 2X pixel clock (2XPCLK). In this type of design, 2XPCLK is distributed across the entire video system, and it is also used to latch the incoming data appearing at pins Y[7:0] and C[7:0]. **Figure 7** on page 8 shows all timing referenced to the 2XPCLK output signal (loaded with 50pF).

Video Encoder Modes

Combinations of the two signals MOD1 and MOD0 select the various power saving modes as shown below.

Table 3 • Video Encoder Modes

MOD1	MOD0	Video Encoder Mode
1	1	NTSC
1	0	PAL
0	1	PAL-60
0	0	Sleep mode (Encoder off, both PLLs running)

Frequency Select Modes

The frequency select input FS affects the DCLK and ACLK outputs as shown below:

FS = 1 (default) DCLK = 40.5 MHz, ACLK = 16.934 MHz

FS = 0 DCLK = 33.9 MHz, ACLK = 11.289 MHz

Timing Diagrams

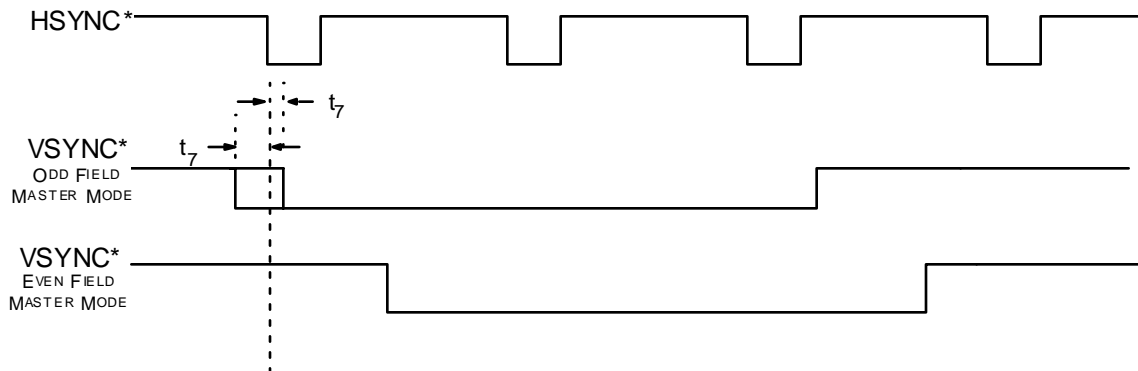

Figure 5: HSYNC* and VSYNC* Timing

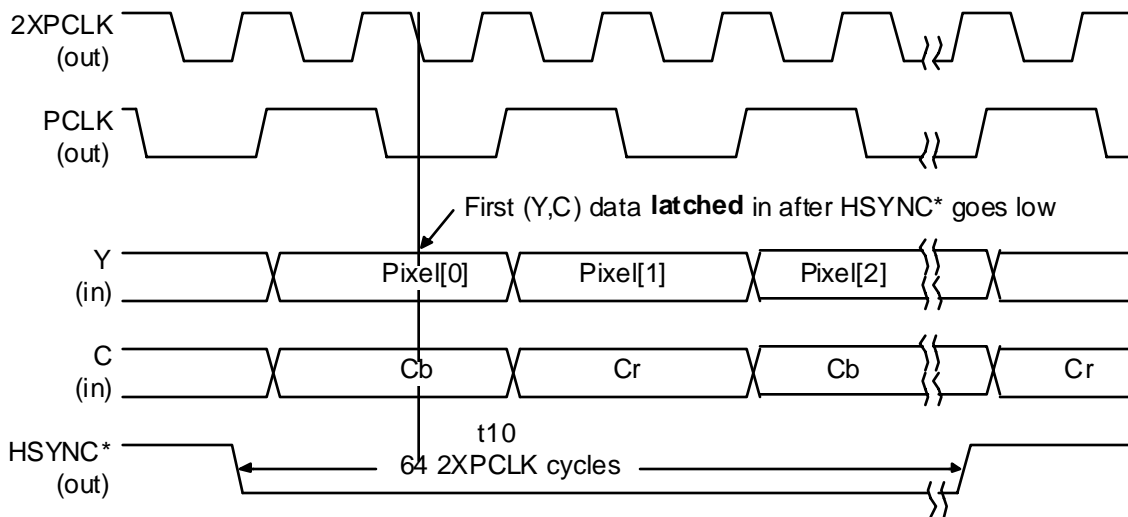

Figure 6: Cb, Cr Sequence Diagram

Data is latched into the device on the falling edge of 2XPCLK, when PCLK is low.

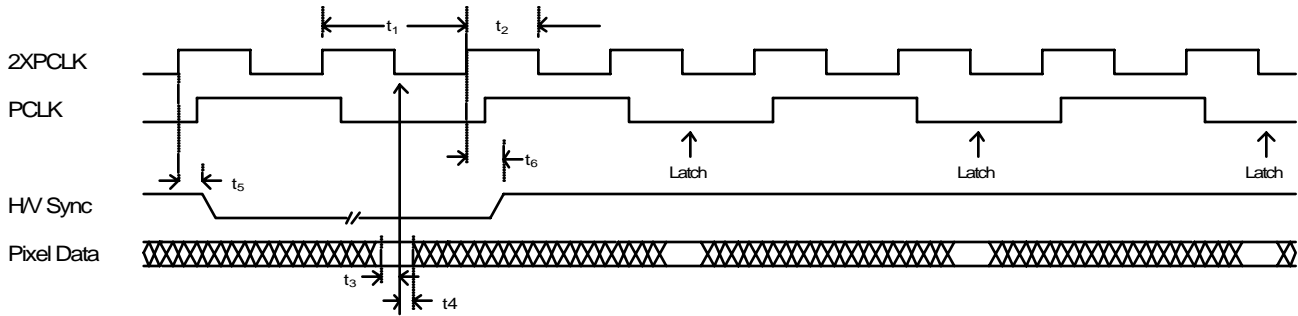

Figure 7: Clock/Data/Synchronization Timing Diagram

Note: Refer to **Table 8** on page 14 for timing values

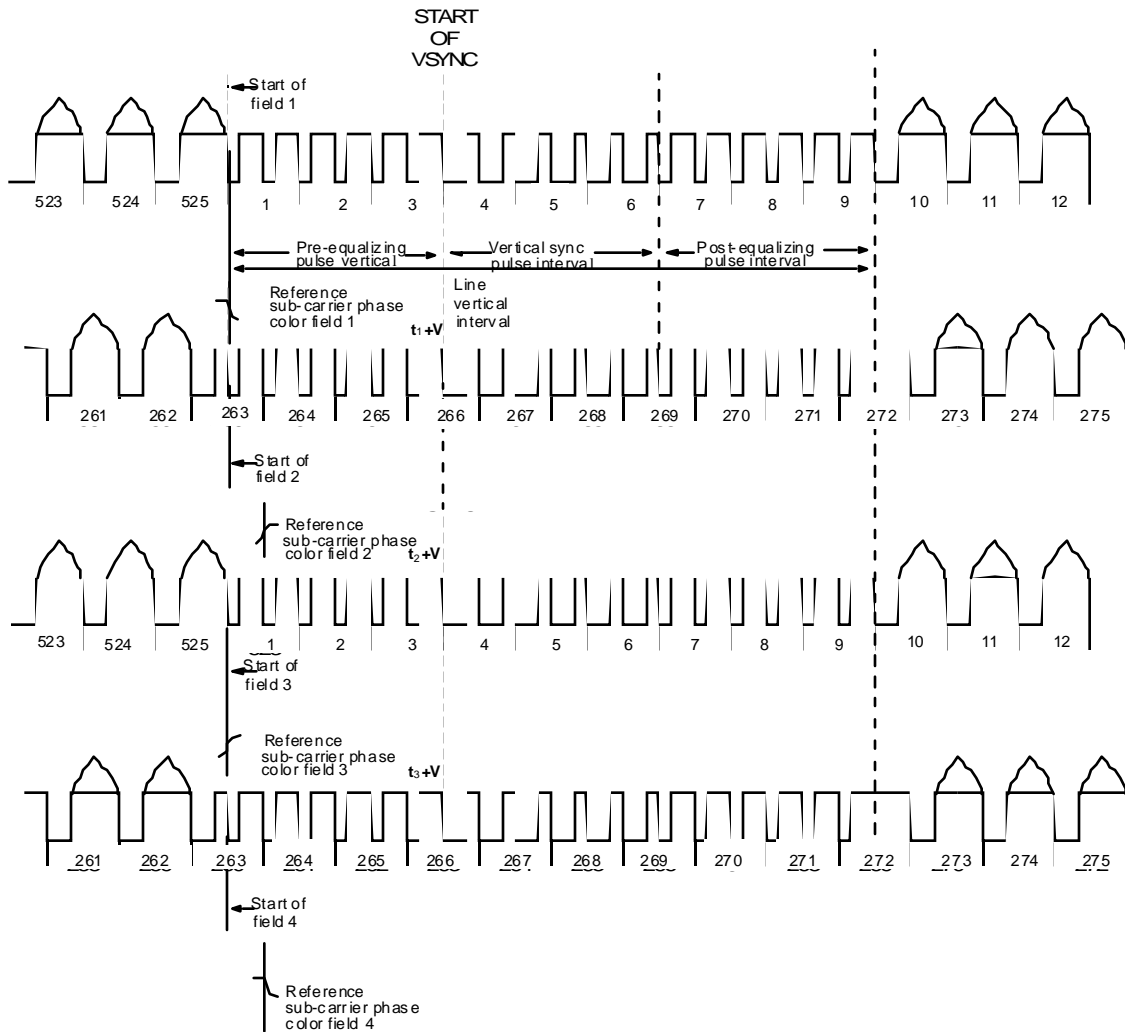

Figure 8: Interlaced NTSC Timing Diagram

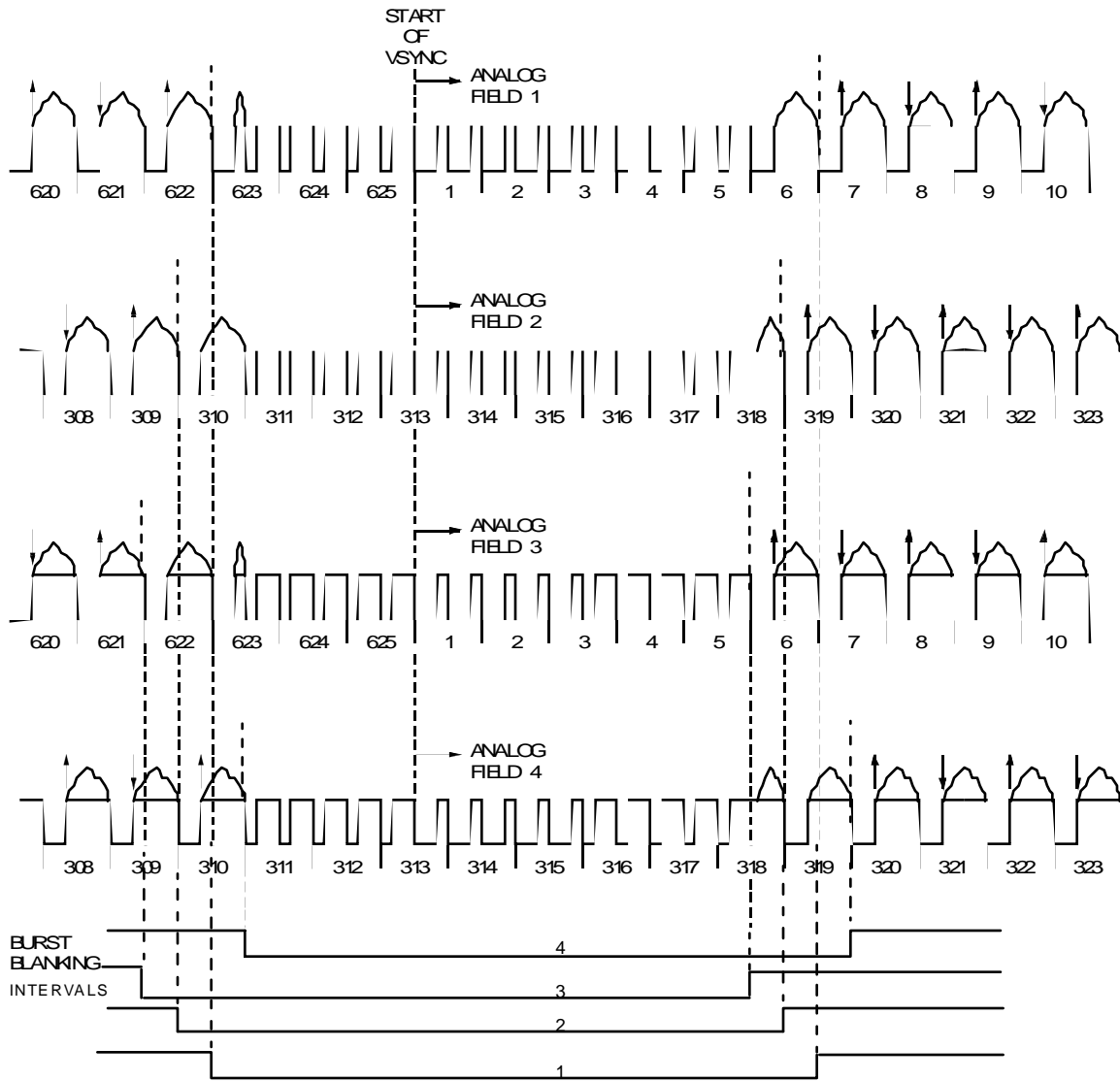
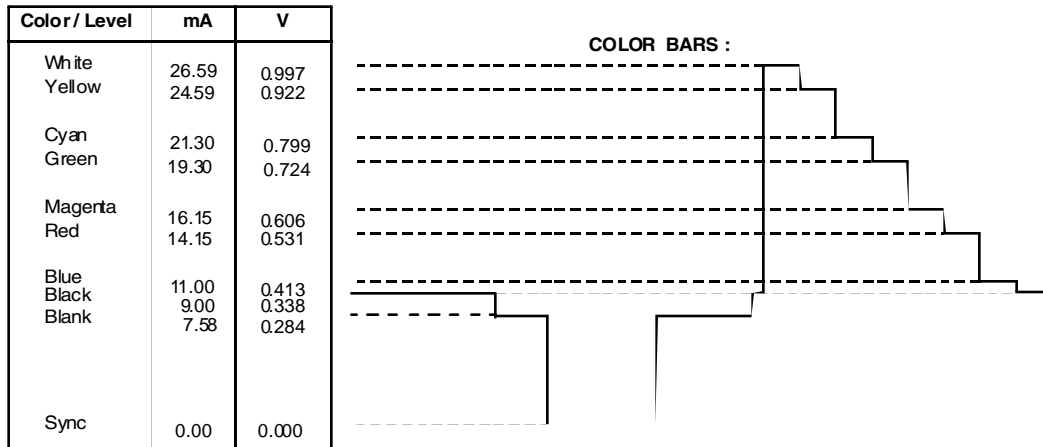

Figure 9: Interlaced PAL Timing Diagram



Note: 1 100% amplitude, 100% saturation color bars are shown

Note: 2 $V_{ref} = 1.235V$, $R_{SET} = 360\Omega$, 75Ω doubly terminated load

Figure 10: NTSC Y (Luminance) Output Waveform



Note: 1 100% amplitude, 100% saturation color bars are shown

Note: 2 $V_{ref} = 1.235V$, $R_{SET} = 360\Omega$, 75Ω doubly terminated load

Figure 11: PAL Y (Luminance) Video Output Waveform

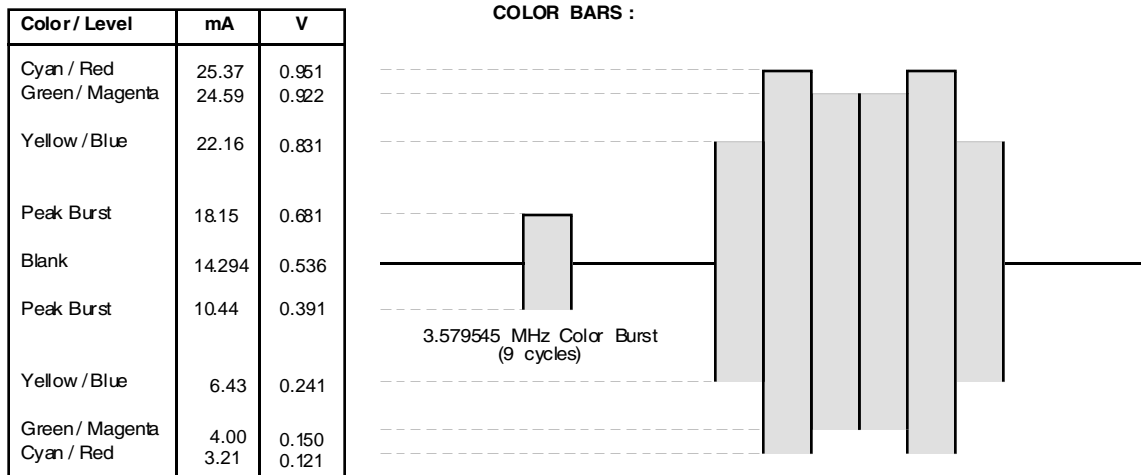

Note: 1 100% amplitude, 100% saturation color bars are shown

Note: 2 $V_{ref} = 1.235V$, $R_{SET} = 360\Omega$, 75Ω doubly terminated load

Figure 12: NTSC C (Chrominance) Video Output Waveform

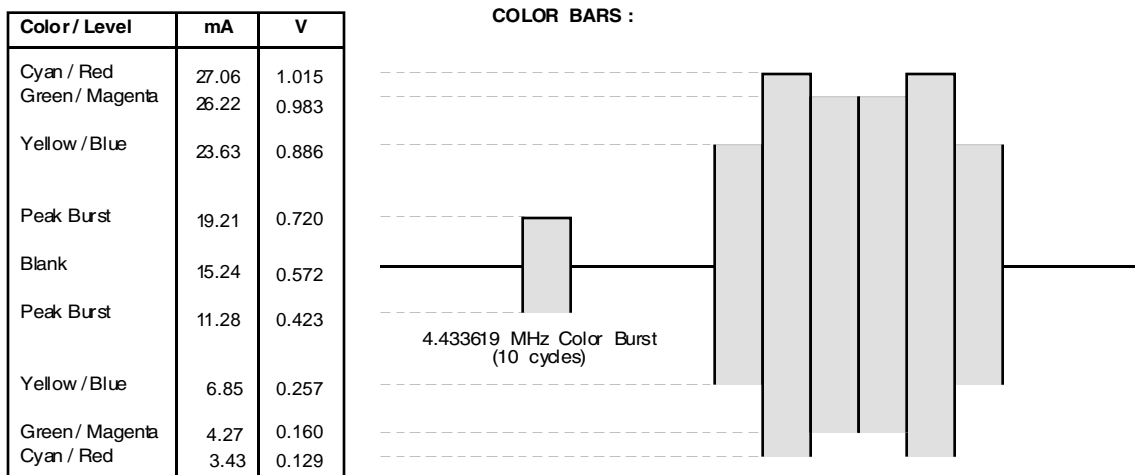

Note: 1 100% amplitude, 100% saturation color bars are shown

Note: 2 $V_{ref} = 1.235V$, $R_{SET} = 360\Omega$, 75Ω doubly terminated load

Figure 13: PAL C (Chrominance) Video Output Waveform

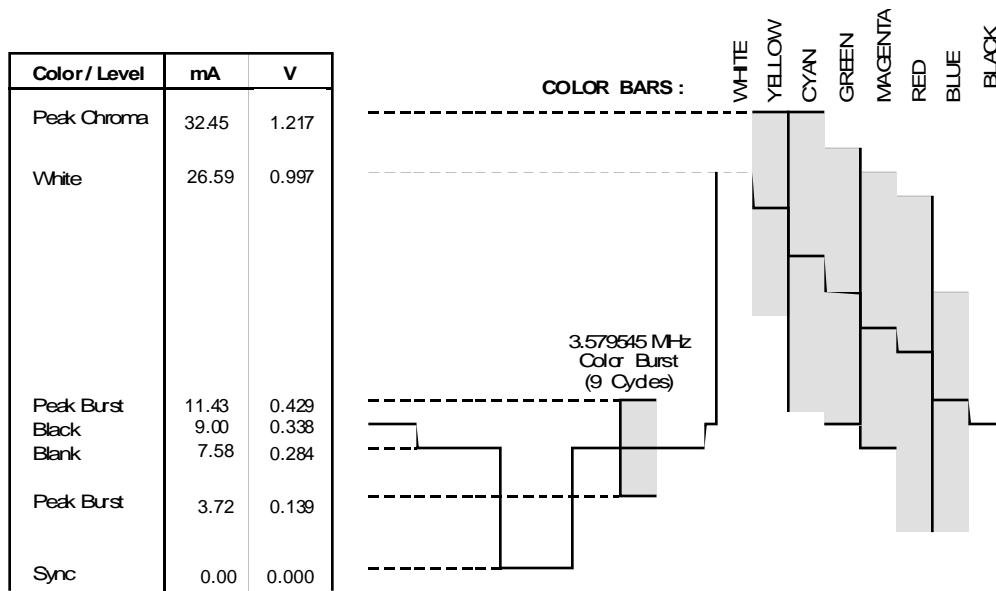

Figure 14: Composite NTSC Video Output Waveform

Note: $V_{ref} = 1.235V$, $R_{SET} = 360\Omega$, 75Ω doubly terminated load

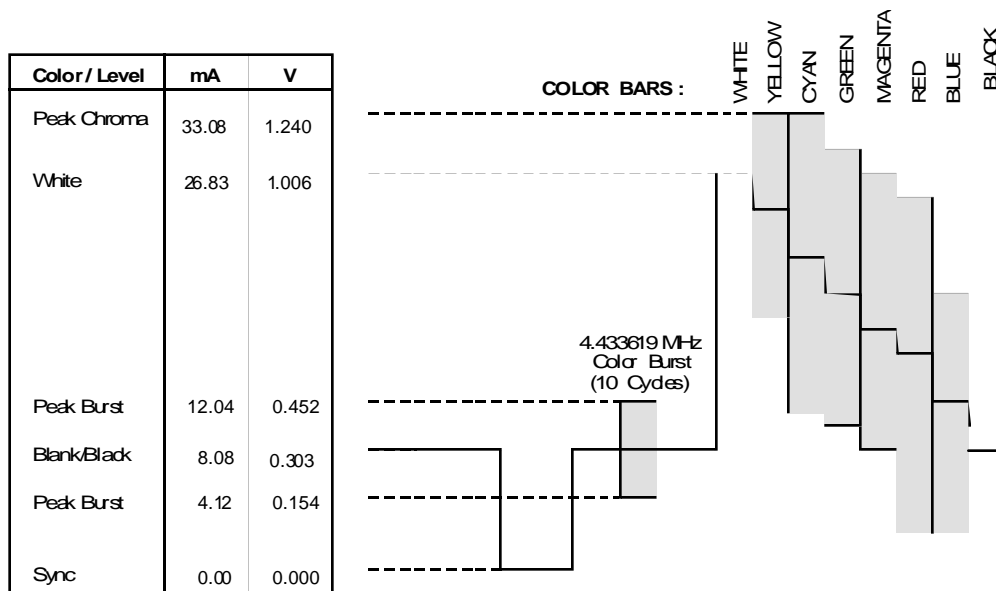

Figure 15: Composite PAL Video Output Waveform

Note: $V_{ref} = 1.235V$, $R_{SET} = 360\Omega$, 75Ω doubly terminated load

Electrical Specifications

Table 4 • Absolute Maximum Ratings

Symbol	Description	Min	Typ	Max	Units
	VDD relative to GND	- 0.5		7.0	V
	Input voltage of all digital pins ¹	GND - 0.5		V _{DD} + 0.5	V
T _{SC}	Analog output short circuit duration		Indefinite		Sec
T _{AMB}	Ambient operating temperature	- 55		125	°C
T _{STOR}	Storage temperature	- 65		150	°C
T _J	Junction temperature			150	°C
T _{VPS}	Vapor phase soldering (one minute)			220	°C
P _{MAX}	Maximum power dissipation			TBD	W

Note: Stresses greater than those listed under absolute maximum ratings may cause permanent damage to the device. These are stress ratings only. Functional operation of the device at these or any other conditions above those indicated under the normal operating conditions is not recommended. Exposure to absolute maximum rating conditions for extended periods may affect reliability.

The device is fabricated using high-performance CMOS technology. It should be handled as an ESD-sensitive device. Voltage on any signal pin that exceeds the power supply voltage by more than +0.5V can induce destructive latchup.

Table 5 • Recommended Operating Conditions

Symbol	Description	Min	Typ	Max	Units
AVDD	Analog supply voltage		5.00		
DVDD	Digital supply voltage		5.00		
T _A	Ambient operating temperature	0	25	70	°C
R _L	Output load to DAC outputs		37.5		Ω

Table 6 • Electrical Characteristics (Operating Conditions: T_A = 0°C – 70°C, V_{DD} = 5V ± 5%)

Symbol	Description	Min	Typ	Max	Unit
	Video D/A resolution	9	9	9	Bits
	Full scale output current		33.08		mA
	Video level error using internal reference			10	%
	Total Current Consumption		135		mA

Note: As applied to Tables 4, 5, and 6, Recommended Operating Conditions are used as test conditions unless otherwise specified. RSET = 360Ω and NTSC CCIR601 operation. Typical values are based on 25°C and +5V.

Table 7 • Digital Inputs / Outputs

Symbol	Description	Test Condition @ T _A = 25°C	Min	Typ	Max	Units
V _{OH}	Output high voltage	I _{OH} = - 400 μA	2.4			V
V _{OL}	Output low voltage	I _{OL} = 3.2 mA			0.4	V
V _{IH}	Input high voltage		2.0		V _{DD} + 0.5	V
V _{IL}	Input low voltage		GND - 0.5		0.8	V
I _{PU}	Input internal pull-up current		5		25	μA
I _{LK}	Input leakage current		-10		10	μA
CD _{IN}	Input capacitance	f = 1 MHz, V _{IN} = 2.4V		7		pF
CD _{OUT}	Output capacitance			10		pF

Electrical Specifications (continued)

Table 8 • AC Characteristics

Symbol	Description	Min	Typ	Max	Units
t_1	2XPCLK		37		ns
t_2	2XPCLK high time	14.8		22.2	ns
t_3	Pixel/Sync setup time	6			ns
t_4	Pixel/Sync hold time	3			ns
t_5	Sync active delay time	3			ns
t_6	Sync inactive delay time			17	ns
t_7	HSYNC* to VSYNC* delay	30		30	ns
t_{10}	HSYNC* pulse width	$64 \times t_1$			ns
	VSYNC* delay time	17		20	ns
	VSYNC* pulse width	2.0			Hor. lines

Test Conditions: Unless otherwise specified, the testing conditions are the same as in Table 5, “Recommended Operating Conditions,” on page 13. TTL input values are 0 – 3V, with input rise / fall times < 3 ns, measured between the V_{IL} and V_{IH} . Timing reference points at 50% for non-TTL inputs and outputs. TTL reference points at 1.5V for inputs and outputs. Analog output load < 10 pF.

Since the CH7203 does not have a pixel clock input, all input signal timing is chosen with respect to the output clock timing of 2XPCLK and PCLK. PCLK can be used at the “Qualifying” clock for certain MPEG decoders.

ORDERING INFORMATION			
Part number	Package type	Number of pins	Voltage supply
CH7203-V	PLCC	44	5V

Chrontel

**2210 O'Toole Avenue
San Jose, CA 95131-1326
Tel: (408) 383-9328
Fax: (408) 383-9338**