

# 10-18GHz Low Noise, Variable Gain Amplifier

## GaAs Monolithic Microwave IC

*preliminary*

### Description

The CHA2291 is a high gain four-stage monolithic low noise amplifier with variable gain. It is designed for a wide range of applications, from military to commercial communication systems. The backside of the chip is both RF and DC grounded. This helps simplify the assembly process.

The circuit is manufactured with a PM-HEMT process, 0.25µm gate length, via holes through the substrate, air bridges and electron beam gate lithography. It is available in chip form.

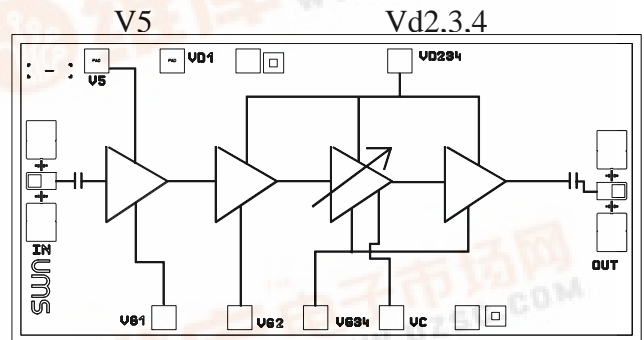

Vg1 Vg2 Vg3,4 Vc

Typical on wafer measurements : Gain & NF

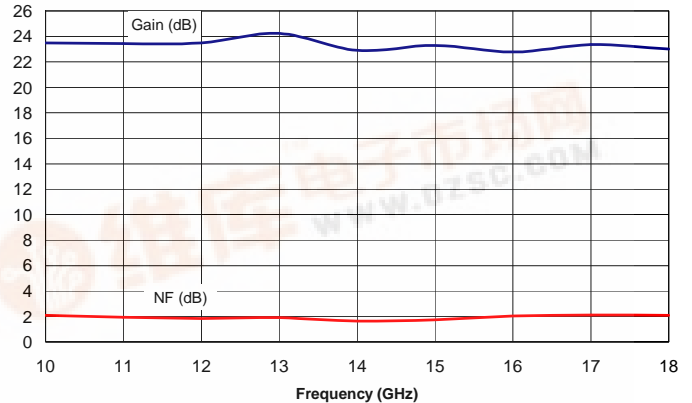

### Main Features

- Frequency range : 10-18GHz
- 2.2dB Noise Figure.
- 23dB gain
- Gain control range: 20dB
- DC power consumption: 180mA @ 5V
- Chip size : 2.49 X 1.23 X 0.10 mm

### Main Characteristics

Tamb. = 25°C

	Parameter	Min	Typ	Max	Unit
Fop	Operating frequency range	10		18	GHz
G	Small signal gain		23		dB
NF	Noise figure		2.2		dB
Gctrl	Gain control range with Vc variation		20		dB
Id	Bias current		180		mA

ESD Protection : Electrostatic discharge sensitive device. Observe handling precautions !



**Electrical Characteristics for Broadband Operation**

Tamb = +25°C, V5=Vd2,3,4= 5V

*preliminary*

Symbol	Parameter	Min	Typ	Max	Unit
Fop	Operating frequency range	10		18	GHz
G	Small signal gain (1)		23		dB
$\Delta G$	Small signal gain flatness (1)		$\pm 1$		dB
Is	Reverse isolation (1)		60		dB
NF	Noise figure with Vc=1.2V (1)		2.2		dB
Gctrl	Gain control range versus Vc		20		dB
P1dB	Output power at 1dB compression with Vc=1.2V		10		dBm
VSWRin	Input VSWR (1)			3.0:1	
VSWRout	Output VSWR (1)			2.5:1	
Vd	DC voltage V5= Vd2,3,4 Vc	-1.5	5 [-0.7, +1.2]	+1.3	V V
Id1	Bias current (2) with Vc=1.2V		25		mA
Id	Bias current total (3) with Vc=1.2V		180		mA

(1) These values are representative of on-wafer measurements that are made without bonding wires at RF ports.

(2) For optimum noise figure, the bias current Id1 should be adjusted to 25mA with Vg1 voltage.

(3) With Id1=25mA, adjust Vg2,3,4 voltage for a total drain current around 180mA.

**Absolute Maximum Ratings**

Tamb. = 25°C (1)

Symbol	Parameter	Values	Unit
Vd	Maximum Drain bias voltage	+5.25	V
Id	Maximum drain bias current	250	mA
Vg	Gate bias voltage	-2.5 to +0.4	V
Vc	Maximum Control bias voltage	+1.5	V
Vdg	Maximum drain to gate voltage (Vd - Vg)	+5.0	V
Pin	Maximum input power overdrive (2)	+15	dBm
Tch	Maximum channel temperature	+175	°C
Ta	Operating temperature range	-40 to +85	°C
Tstg	Storage temperature range	-55 to +125	°C

(1) Operation of this device above any one of these parameters may cause permanent damage.

(2) Duration < 1s.

Typical on wafer Measurements

*preliminary*

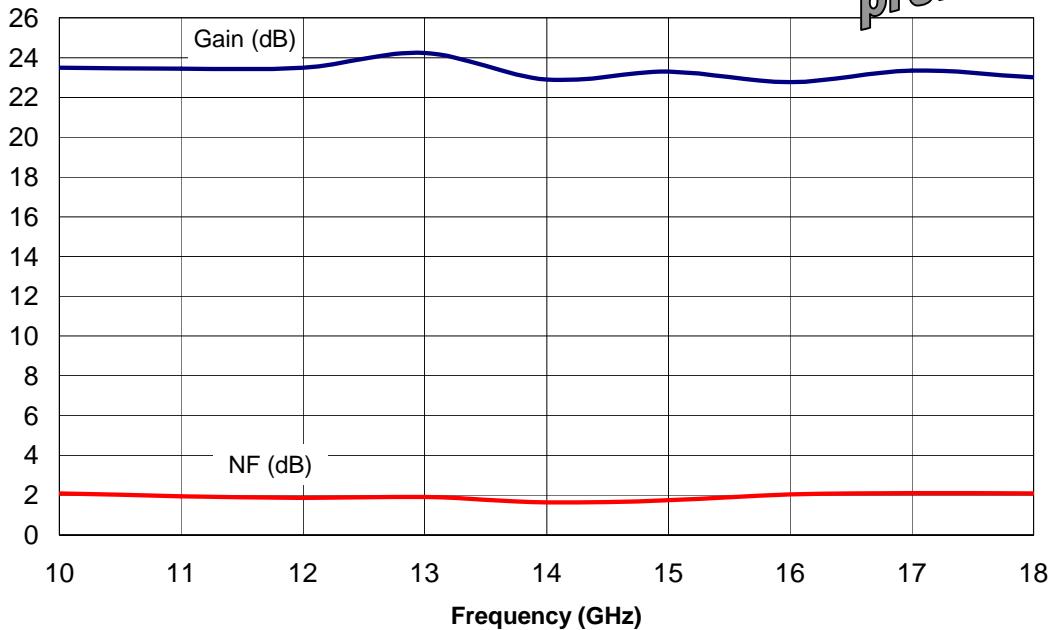

Bias Conditions :  $V_5=V_{d2,3,4}= 5V$ ,  $V_{g1}$  for  $I_{d1}= 25mA$ ,  $V_{g2}=V_{g3,4}= -0.5V$ ,  $V_c= 1.2V$   
 Gain & Noise Figure versus frequency

In jig Measurements

All these measurements include the jig losses (about 0.5dB on gain, 0.2dB on noise figure and 0.3dB on output power).

Bias Conditions :  $V_5=V_{d2,3,4}= 5V$ ,  $V_{g1}$  for  $I_{d1}= 25mA$ ,  $V_{g2}=V_{g3,4}= -0.5V$ ,  $V_c= 1.2V$

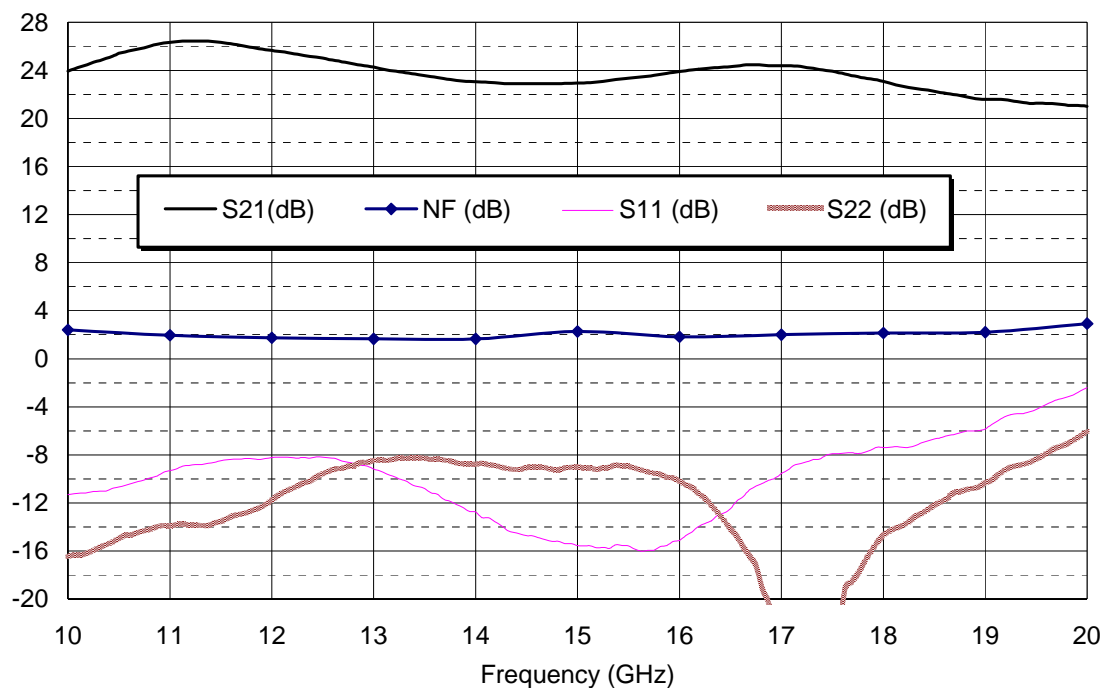

Gain, Return Loss & Noise Figure versus frequency

*preliminary*

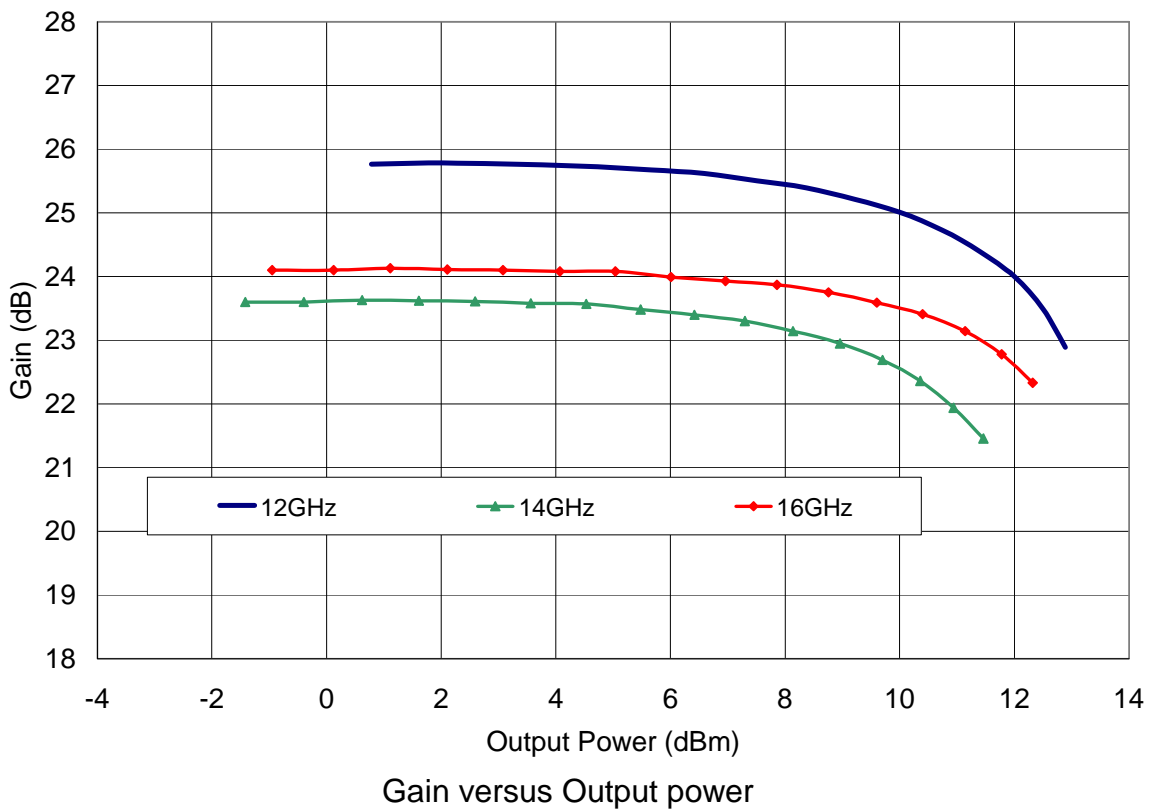
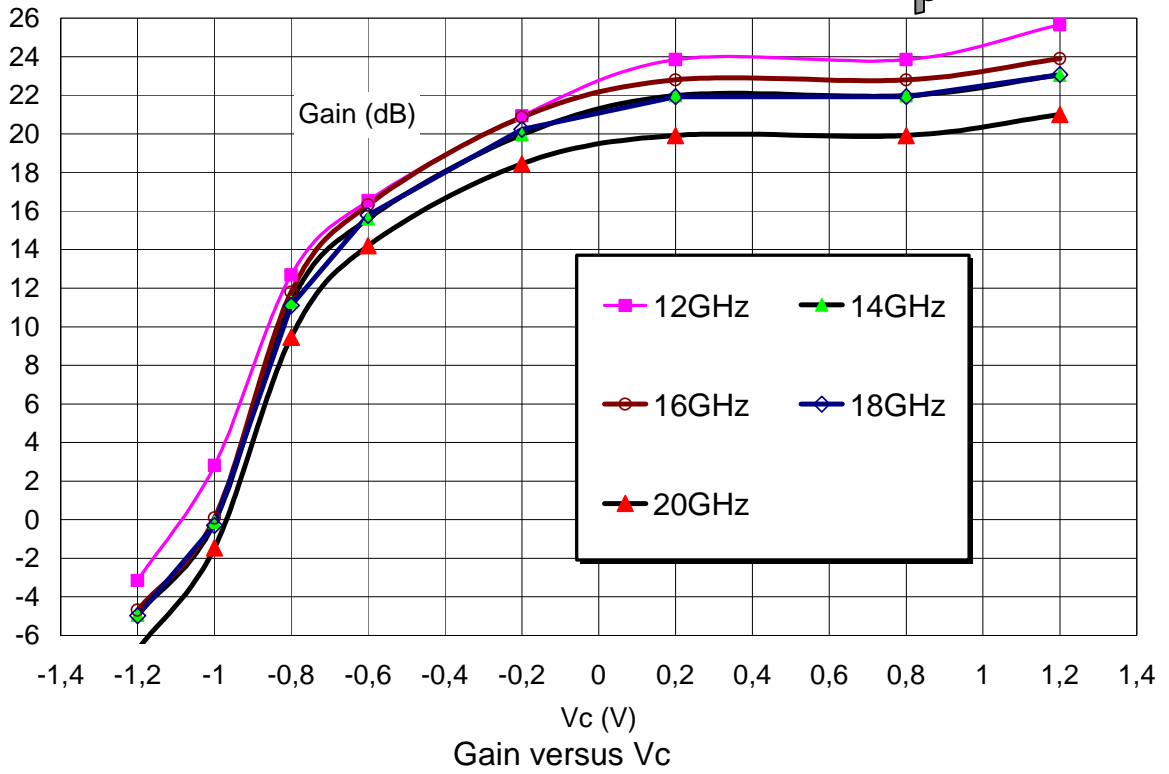

Chip Assembly and Mechanical Data

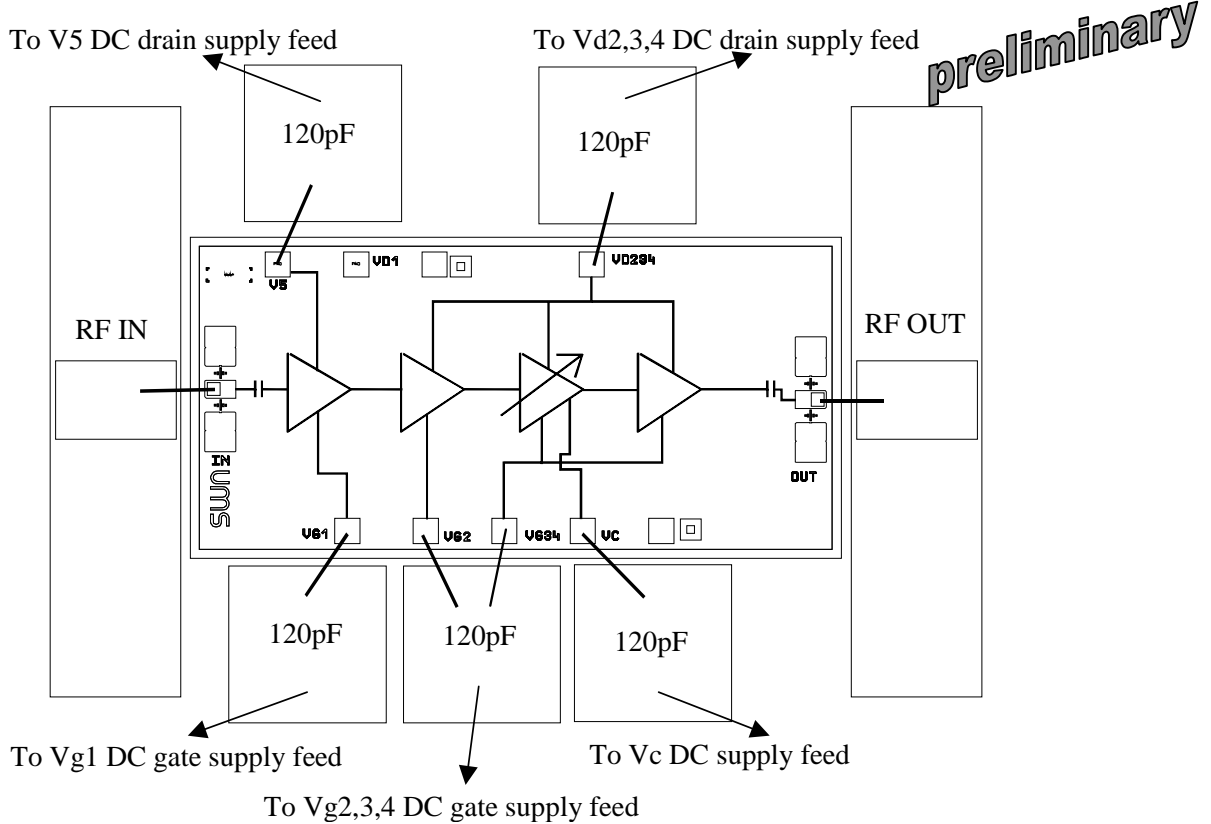

Note : Supply feed should be capacitively bypassed. 25µm diameter gold wire is recommended  
Bond Pad:100 x 100 µm

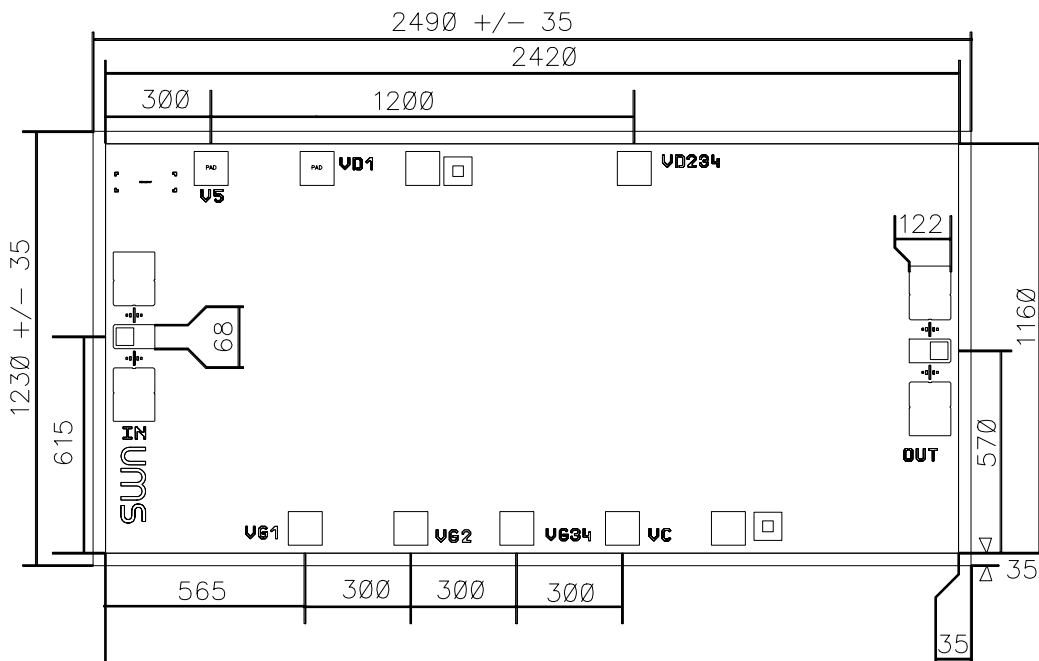

**Bonding pad positions**  
( Chip thickness : 100µm. All dimensions are in micrometers )

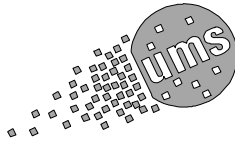

*preliminary*

## Ordering Information

Chip form : CHA2291-99F/00

Information furnished is believed to be accurate and reliable. However **United Monolithic Semiconductors S.A.S.** assumes no responsibility for the consequences of use of such information nor for any infringement of patents or other rights of third parties which may result from its use. No license is granted by implication or otherwise under any patent or patent rights of **United Monolithic Semiconductors S.A.S.** Specifications mentioned in this publication are subject to change without notice. This publication supersedes and replaces all information previously supplied. **United Monolithic Semiconductors S.A.S.** products are not authorised for use as critical components in life support devices or systems without express written approval from **United Monolithic Semiconductors S.A.S.**