



November 2002

# ADC12281

## 12-Bit, 20 MSPS Single-Ended Input, Pipelined A/D Converter

### General Description

The ADC12281 is a monolithic CMOS analog-to-digital converter capable of converting analog input signals into 12-bit digital words at 20 megasamples per second (MSPS). It utilizes a pipeline architecture to minimize die size and power dissipation. Self-calibration and error correction maintain accuracy and performance over temperature.

The ADC12281 operates on a 5V power supply and can digitize single-ended analog input signals in the range of 0V to 2V. A single convert clock controls the conversion operation and all digital I/O is TTL compatible.

The ADC12281 is designed to minimize external components necessary for the analog input interface. An internal sample-and-hold circuit samples the single-ended analog input and an internal amplifier buffers the reference voltage input.

The Power Down feature reduces power consumption to 20 mW, typical.

The ADC12281 is available in the 32-lead TQFP package and is designed to operate over the industrial temperature range of -40°C to +85°C.

### Features

- Single 5V power supply
- Single-ended analog input

- Internal sample-and-hold
- Internal reference buffer amplifier
- Low offset and gain errors

### Key Specifications

■ Resolution	12 bits
■ Conversion rate	up to 20 MSPS
■ DNL	0.35 LSB (typ)
■ SNR	65.5 dB (typ)
■ ENOB	10.5 bits (typ)
■ Analog input range	2 V <sub>PP</sub> (min)
■ Supply voltage	+5V ±5%
■ Power consumption, 20 MHz	443 mW (typ)

### Applications

- Digital signal processing front end
- Digital television
- Radar
- High speed data links
- Waveform digitizers
- Quadrature demodulation

### Connection Diagram

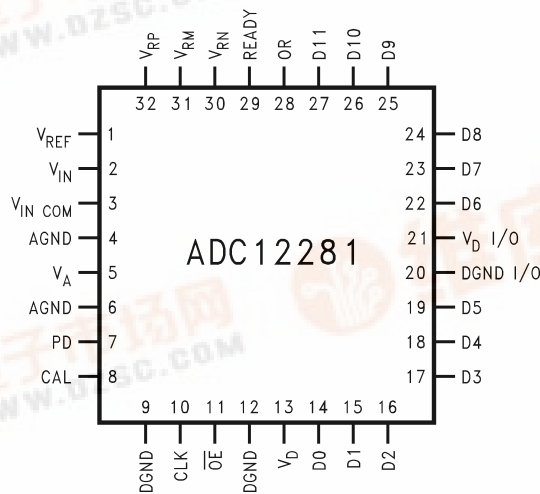

10102701

**32-Lead TQFP Package**  
**Order Number ADC12281CIVT**  
**See NS Package Number VBE32A**

ADC12281 12-Bit, 20 MSPS Single-Ended Input, Pipelined A/D Converter



### Ordering Information

<b>Industrial</b> ( $-40^{\circ}\text{C} \leq T_A \leq +85^{\circ}\text{C}$ )	<b>Package</b>
ADC12281CIVT	32-Pin TQFP

### Simplified Block Diagram

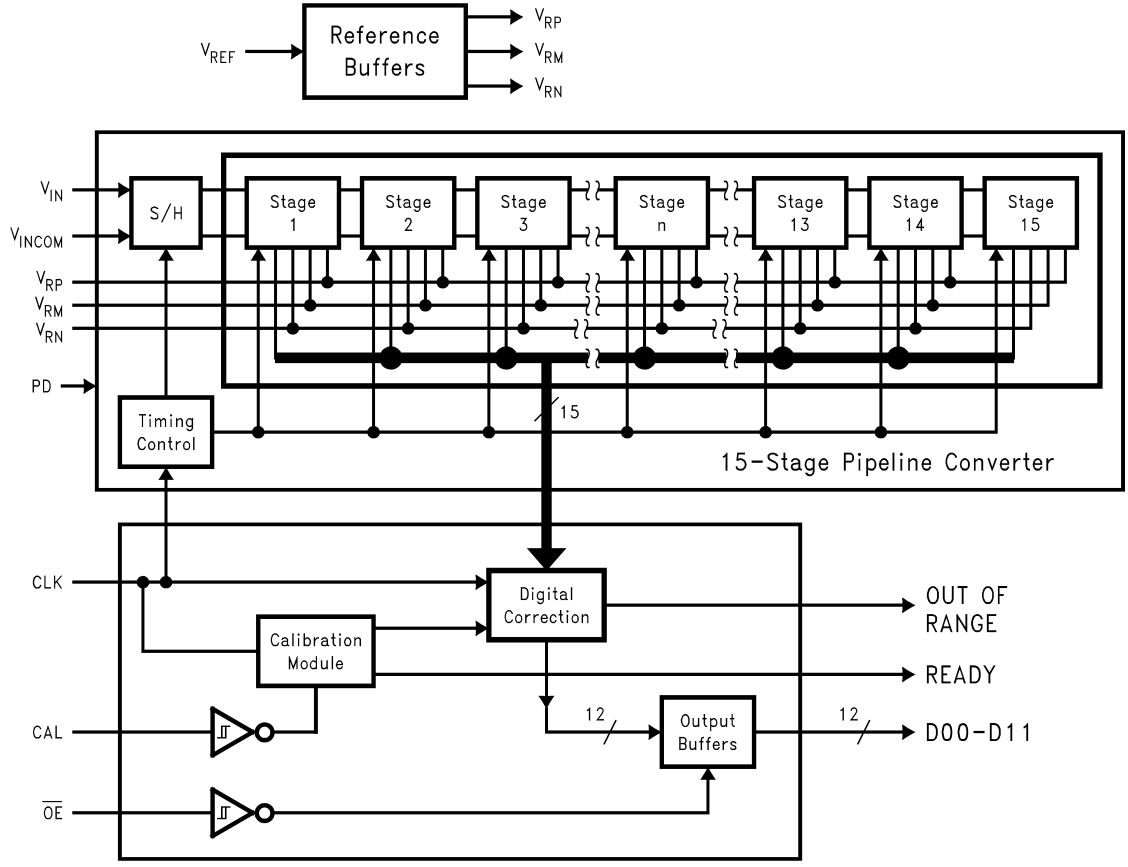

10102702

### Pin Descriptions and Equivalent Circuits

Pin	Symbol	Equivalent Circuit	Description
2	$V_{IN}$		Single-ended analog signal input. With a 2.0V reference voltage, input signal voltages in the range of 0V to 2.0V will be converted. See Section 1.2.
1	$V_{REF}$		Reference voltage input. This pin should be driven from an accurate, stable reference source in the range of 1.8V to 2.2V and bypassed to a low-noise ground with a monolithic ceramic capacitor, nominally 0.01 $\mu\text{F}$ . See Section 1.1.

**Pin Descriptions and Equivalent Circuits** (Continued)

Pin	Symbol	Equivalent Circuit	Description
32	$V_{RP}$		Positive reference bypass pin. Bypass with a 0.1 $\mu$ F capacitor. Do not connect anything else to this pin. See Section 3.1.
31	$V_{RM}$		Reference midpoint bypass pin. Bypass with a 0.1 $\mu$ F capacitor. Do not connect anything else to this pin. See Section 3.1.
30	$V_{RN}$		Negative reference bypass pin. Bypass with a 0.1 $\mu$ F capacitor. Do not connect anything else to this pin. See Section 3.1.
10	CLOCK		Sample clock input, TTL compatible. Amplitude should not exceed 3 $V_{P-P}$ .
8	CAL		Calibration request, active High. Calibration cycle starts when CAL returns to logic low. CAL is ignored during power-down mode. See Section 2.2.
7	PD		Power-down, active High, ignored during calibration cycle. See paragraph 2.4.
11	$\overline{OE}$		Output enable control, active low. When this pin is high the data outputs are in TRI-STATE® (high-impedance) mode.
28	OR		Over-range indicator. This pin is at a logic High, for $V_{IN} < 0$ or for $V_{IN} > V_{REF}$ .
29	READY		Device ready indicator, active High. This pin will be at a logic Low during a calibration cycle and while the device is in the power down mode.
14–19, 22–27	D0–D11		Digital output word, CMOS compatible. D0 (pin 19) is LSB, D11 (pin 36) is MSB. Load with no more than 25 pF.

## Pin Descriptions and Equivalent Circuits (Continued)

Pin	Symbol	Equivalent Circuit	Description
3	$V_{IN\ COM}$		Analog input common. Connect to a quiet point in analog ground near the driving device. See Section 1.2.
5	$V_A$		Positive analog supply pin. Connect to a clean, quiet voltage source of +5V. $V_A$ and $V_D$ should have a common supply and be separately bypassed with a 5 $\mu$ F to 10 $\mu$ F capacitor and a 0.1 $\mu$ F chip capacitor.
4, 6	AGND		The ground return for the analog supply, AGND and DGND should be connected together close to the ADC12281 package. See Section 5.0.
13	$V_D$		Positive digital supply pin. Connect to a clean, quiet voltage source of +5V. $V_A$ and $V_D$ should have a common supply and be separately bypassed with a 5 $\mu$ F to 10 $\mu$ F capacitor and a 0.1 $\mu$ F chip capacitor.
9, 12	DGND		The ground return for the digital supply. AGND and DGND should be connected together close to the ADC12281 package. See Section 5.0.
21	$V_D\ I/O$		The digital output driver supply pins. This pin can be operated from a supply voltage of 3V to 5V, but the voltage on this pin should never exceed the $V_D$ supply pin voltage. See Section 3.4.
20	DGND I/O		The ground return for the digital output drivers. This pin should be returned to a point in the digital ground that is removed from the other ground pins of the ADC12281.

## Absolute Maximum Ratings (Notes 1, 2)

If Military/Aerospace specified devices are required, please contact the National Semiconductor Sales Office/Distributors for availability and specifications.

Supply Voltages ( $V_A$ , $V_D$ , $V_D$ I/O)	6.5V
$ V_A - V_D $	$\leq 100$ mV
$V_D$ I/O- $V_A$ , $V_D$ I/O- $V_D$	$\leq 300$ mV
Voltage on Any Input or Output Pin	-0.3V to $V_A$ +0.3V
Input Current at Any Pin (Note 3)	$\pm 25$ mA
Package Input Current (Note 3)	$\pm 50$ mA
Power Dissipation at $T_A = 25^\circ\text{C}$	See (Note 4)
ESD Susceptibility	
Human Body Model (Note 5)	2500V
Machine Model (Note 5)	250V

Soldering Temperature, Infrared, (10 sec.) (Note 6)	300°C
Storage Temperature	-65°C to +150°C

## Operating Ratings (Notes 1, 2)

Operating Temperature Range	$-40^\circ\text{C} \leq T_A \leq +85^\circ\text{C}$
Supply Voltage ( $V_A$ , $V_D$ )	+4.75V to +5.25V
Output Driver Supply Voltage ( $V_D$ I/O)	+2.7V to $V_D$
$V_{REF}$ Input	1.8V to 2.2V
CLOCK, CAL, PD, $\overline{OE}$	-0.05V to $V_D$ +0.05V
Ground Difference  AGND-DGND	$\leq 100$ mV

## Converter Electrical Characteristics

The following specifications apply for AGND = DGND = DGND I/O = 0V,  $V_A = V_D = V_D$  I/O = +5V, PD = +5V,  $V_{REF} = +2.0V$ ,  $f_{CLK} = 20$  MHz, 3  $V_{P-P}$  at 50% duty cycle,  $C_L = 25$  pF/pin. After Auto-Cal. **Boldface limits apply for  $T_A = T_J = T_{MIN}$  to  $T_{MAX}$** ; all other limits  $T_A = T_J = 25^\circ\text{C}$  (Notes 7, 8, 9).

Symbol	Parameter	Conditions	Typical (Note 10)	Limits (Note 11)	Units (Limits)
<b>STATIC CONVERTER CHARACTERISTICS</b>					
	Resolution with No Missing Codes			<b>12</b>	Bits (min)
INL	Integral Non-Linearity		$\pm 1.0$	<b><math>\pm 2.5</math></b>	LSB (max)
DNL	Differential Non-Linearity		$\pm 0.35$	<b><math>\pm 0.9</math></b>	LSB (max)
	Full-Scale Error		+3	<b><math>\pm 10</math></b>	LSB (max)
	Zero Error		+7	<b><math>\pm 17</math></b>	LSB (max)
<b>DYNAMIC CONVERTER CHARACTERISTICS</b>					
BW	Full Power Bandwidth		100		MHz
SNR	Signal-to-Noise Ratio	$f_{IN} = 4.43$ MHz, $V_{IN} = 2.0$ $V_{P-P}$	65.5	<b>62.5</b>	dB (min)
SINAD	Signal-to-Noise and Distortion	$f_{IN} = 4.43$ MHz, $V_{IN} = 2.0$ $V_{P-P}$	65	<b>62</b>	dB (min)
ENOB	Effective Number of Bits	$f_{IN} = 4.43$ MHz, $V_{IN} = 2.0$ $V_{P-P}$	10.5	<b>10</b>	Bits (min)
THD	Total Harmonic Distortion	$f_{IN} = 4.43$ MHz, $V_{IN} = 2.0$ $V_{P-P}$	-76		dB
SFDR	Spurious Free Dynamic Range	$f_{IN} = 4.43$ MHz, $V_{IN} = 2.0$ $V_{P-P}$	75		dB
<b>REFERENCE AND ANALOG INPUT CHARACTERISTICS</b>					
$V_{IN}$	Input Voltage Range			$V_{REF}$	V (max)
$C_{IN}$	$V_{IN}$ Input Capacitance	(CLK LOW)	10		pF
		(CLK HIGH)	15		pF
$V_{REF}$	Reference Voltage (Note 14)		2.00	<b>1.8</b>	V (min)
				<b>2.2</b>	V (max)
	Reference Input Leakage Current		10		$\mu\text{A}$
	Reference Input Resistance		1		M $\Omega$

## DC and Logic Electrical Characteristics

The following specifications apply for AGND = DGND = DGND I/O = 0V,  $V_A = V_D = V_D$  I/O = +5V, PD = +5V,  $V_{REF} = +2.0V$ ,  $f_{CLK} = 20$  MHz, 3  $V_{P-P}$  at 50% duty cycle,  $C_L = 25$  pF/pin. After Auto-Cal. **Boldface limits apply for  $T_A = T_J = T_{MIN}$  to  $T_{MAX}$** ; all other limits  $T_A = T_J = 25^\circ\text{C}$  (Notes 7, 8, 9).

Symbol	Parameter	Conditions	Typical (Note 10)	Limits (Note 11)	Units (Limits)
<b>CLOCK, CAL, PD, <math>\overline{OE}</math> DIGITAL INPUT CHARACTERISTICS</b>					
$V_{IH}$	Logical "1" Input Voltage	$V_D = 5.25V$		<b>2.0</b>	V (min)

## DC and Logic Electrical Characteristics (Continued)

The following specifications apply for AGND = DGND = DGND I/O = 0V,  $V_A = V_D = V_D$  I/O = +5V, PD = +5V,  $V_{REF} = +2.0V$ ,  $f_{CLK} = 20$  MHz, 3  $V_{P-P}$  at 50% duty cycle,  $C_L = 25$  pF/pin. After Auto-Cal. **Boldface limits apply for  $T_A = T_J = T_{MIN}$  to  $T_{MAX}$** ; all other limits  $T_A = T_J = 25^\circ C$  (Notes 7, 8, 9).

Symbol	Parameter	Conditions	Typical (Note 10)	Limits (Note 11)	Units (Limits)
$V_{IL}$	Logical "0" Input Voltage	$V_D = 4.75V$		<b>0.8</b>	V (max)
$I_{IH}$	Logical "1" Input Current	$V_{IN} = 5.0V$	10		$\mu A$
$I_{IL}$	Logical "0" Input Current	$V_{IN} = 0V$	-10		$\mu A$
$C_{IN}$	Logic Input Capacitance		8		pF
<b>D0–D11 DIGITAL OUTPUT CHARACTERISTICS</b>					
$V_{OH}$	Logical "1" Output Voltage	$I_{OUT} = -1$ mA		<b>4</b>	V (min)
$V_{OL}$	Logical "0" Output Voltage	$I_{OUT} = 1.6$ mA		<b>0.4</b>	V (max)
$I_{OZ}$	TRI-STATE Output Current	$V_{OUT} = 3V$ or $5V$	100		nA
		$V_{OUT} = 0V$	-100		nA
$+I_{SC}$	Output Short Circuit Source Current	$V_D$ I/O = 3V, $V_{OUT} = 0V$	-29		mA
$-I_{SC}$	Output Short Circuit Sink Current	$V_D$ I/O = 3V, $V_{OUT} = V_D$	28		mA
<b>POWER SUPPLY CHARACTERISTICS</b>					
$I_A$	Analog Supply Current	PD = DGND (active)	85	<b>100</b>	mA (max)
		PD = $V_D$ I/O (power-down mode)	3.5		mA
$I_D$	Digital Supply Current	PD = DGND (active)	3.6	<b>6</b>	mA (max)
		PD = $V_D$ I/O (power-down mode)	1		mA
	Total Power Consumption	PD = DGND (active)	443	<b>530</b>	mW (max)
		PD = $V_D$ I/O (power-down mode)	20		typ

## AC Electrical Characteristics

The following specifications apply for AGND = DGND = DGND I/O = 0V,  $V_A = V_D = V_D$  I/O = +5V, PD = +5V,  $V_{REF} = +2.0V$ ,  $f_{CLK} = 20$  MHz, 3  $V_{P-P}$  at 50% duty cycle,  $C_L = 25$  pF/pin. After Auto-Cal. **Boldface limits apply for  $T_A = T_J = T_{MIN}$  to  $T_{MAX}$** ; all other limits  $T_A = T_J = 25^\circ C$  (Notes 7, 8, 9).

Symbol	Parameter	Conditions	Typical (Note 10)	Limits (Note 11)	Units (Limits)
$f_{CLK}$	Conversion Clock (CLOCK) Frequency		0.5		MHz (min)
				<b>20</b>	MHz (max)
$t_{CONV}$	Conversion Latency			<b>10</b>	Clock Cycles
$t_{OD}$	Data Output Delay after Rising CLK Edge	$V_D$ I/O = 3V	7		ns (max)
		$V_D$ I/O = 5V	5	<b>17</b>	
$I_{OZ}$	Data Outputs into TRI-STATE Mode		16		ns
$t_{OE}$	Data Outputs Active after TRI-STATE		10		ns
$t_{WCAL}$	Calibration Request Pulse Width		3		$T_{CLK}$
$t_{RDYC}$	Ready Low after CAL Request		3		$T_{CLK}$
$t_{CAL}$	Calibration Cycle		4000		$T_{CLK}$
$t_{WPD}$	Power-Down Pulse Width		3		$T_{CLK}$
$t_{RDYPD}$	Ready Low after PD Request		3		$T_{CLK}$
$t_{PD}$	Power-Down Mode Exit Cycle		4000		$T_{CLK}$

**Note 1:** "Absolute Maximum Ratings" indicate limits beyond which damage to the device may occur. Operating Ratings indicate conditions for which the device is functional, but do not guarantee specific performance limits. For guaranteed specifications and test conditions, see the Electrical Characteristics. The guaranteed specifications apply only for the test conditions listed. Some performance characteristics may degrade when the device is not operated under the listed test conditions.

**Note 2:** All voltages are measured with respect to GND = AGND = DGND = DGND I/O = 0V, unless otherwise specified.

**Note 3:** When the input voltage at any pin exceeds the power supplies (that is,  $V_{IN} < AGND$  or  $V_{IN} > V_A$ ,  $V_D$  or  $V_D$  I/O), the current at that pin should be limited to 25 mA. The 50 mA maximum package input current rating limits the number of pins that can safely exceed the power supplies with an input current of 25 mA to two.

## AC Electrical Characteristics (Continued)

**Note 4:** The absolute maximum junction temperature ( $T_{JMAX}$ ) for this device is 150°C. The maximum allowable power dissipation is dictated by  $T_{JMAX}$ , the junction-to-ambient thermal resistance ( $\theta_{JA}$ ), and the ambient temperature ( $T_A$ ), and can be calculated using the formula  $P_D MAX = (T_{JMAX} - T_A) / \theta_{JA}$ . In the 32-pin TQFP,  $\theta_{JA}$  is 79°C/W, so  $P_D MAX = 1,582$  mW at 25°C and 949 mW at the maximum operating ambient temperature of 75°C. Note that the power dissipation of this device under normal operation will typically be about 125 mW (typical power dissipation + 20 mW TTL output loading). The values for maximum power dissipation listed above will be reached only when the ADC12281 is operated in a severe fault condition (e.g., when input or output pins are driven beyond the power supply voltages, or the power supply polarity is reversed). Obviously, such conditions should always be avoided.

**Note 5:** Human body model is 100 pF capacitor discharged through a 1.5 kΩ resistor. Machine model is 220 pF discharged through 0Ω.

**Note 6:** See AN-450, "Surface Mounting Methods and Their Effect on Product Reliability", or the section entitled "Surface Mount" found in any post 1986 National Semiconductor Linear Data Book, for other methods of soldering surface mount devices.

**Note 7:** The inputs are protected as shown below. Input voltage magnitudes up to 5V above  $V_A$  or to 5V below GND will not damage this device, provided current is limited per (Note 3). However, errors in the A/D conversion can occur if the input goes above  $V_A$  or below GND by more than 100 mV. As an example, if  $V_A$  is 4.75V, the full-scale input voltage must be  $\leq 4.85V$  to ensure accurate conversions.

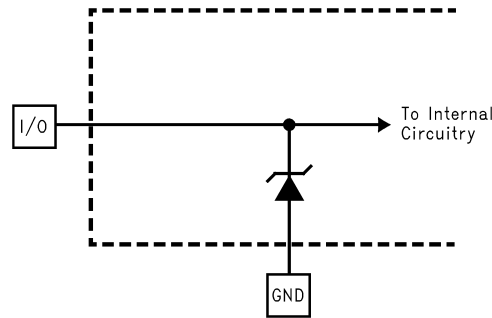

10102708

**ESD Protection Scheme for Analog Input and Digital Output Pins**

**Note 8:** To guarantee accuracy, it is required that  $|V_A - V_{DI}| \leq 100$  mV and separate bypass capacitors are used at each power supply pin.

**Note 9:** With the test condition for  $V_{REF} = +2.0V$ , the 12-bit LSB is 488  $\mu V$ .

**Note 10:** Typical figures are at  $T_A = T_J = 25^\circ C$ , and represent most likely parametric norms. Test limits are guaranteed to National's AOQL (Average Outgoing Quality Level).

**Note 11:** Tested limits are guaranteed to National's AOQL (Average Outgoing Quality Level).

**Note 12:** Integral Non-Linearity is defined as the deviation of the analog value, expressed in LSBs, from the straight line that passes through positive full-scale and zero.

**Note 13:** Timing specifications are tested at the TTL logic levels,  $V_{IL} = -0.4V$  for a falling edge and  $V_{IH} = 2.4V$  for a rising edge. TRI-STATE output voltage is forced to 1.4V.

**Note 14:** Optimum SNR performance will be obtained by keeping the reference input in the 1.8V to 2.2V range. The LM4041CIM3-ADJ (SOT-23 package), the LM4041CIZ-ADJ (TO-92 package), or the LM4041CIM-ADJ (SO-8 package) bandgap voltage reference is recommended for this application.

## Transfer Characteristics

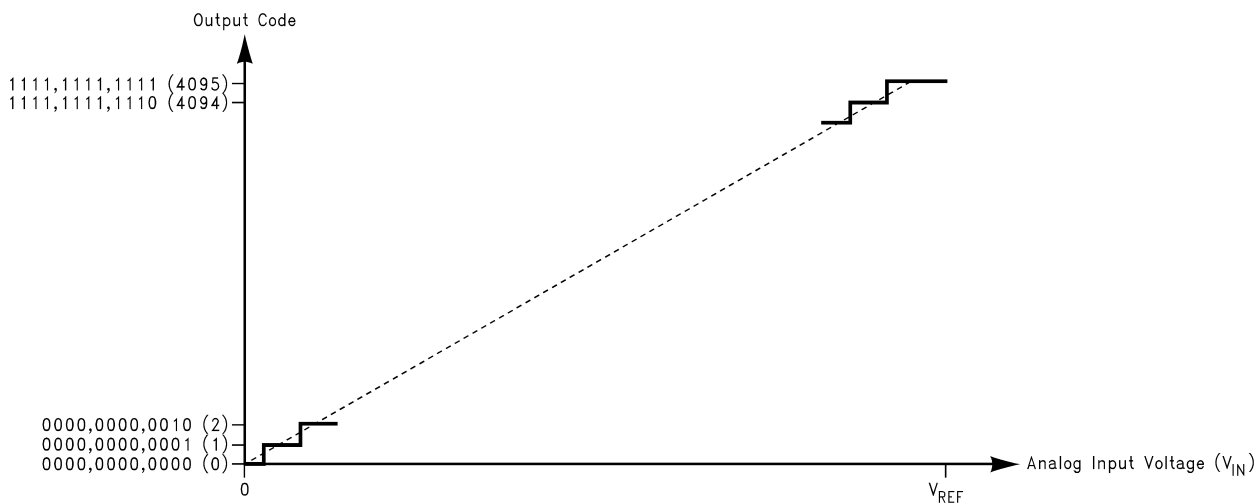

10102709

**FIGURE 1. Transfer Characteristics**

## Transfer Characteristics (Continued)

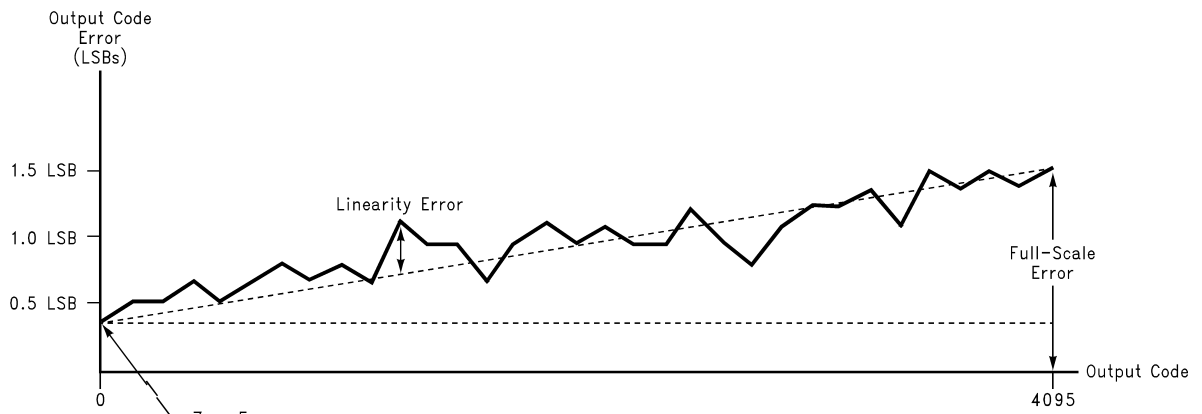

10102710

FIGURE 2. Errors Reduced after Auto-Cal Cycle

## Timing Diagrams

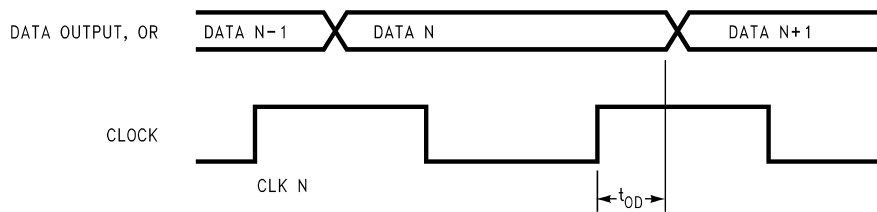

10102711

Data Output Timing

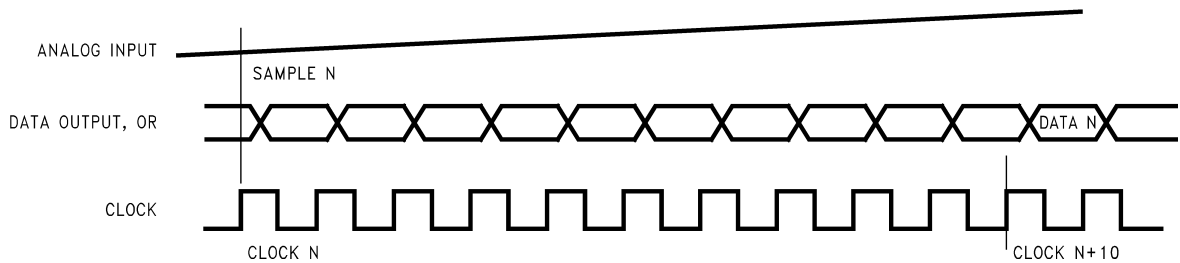

10102712

Data Output Latency

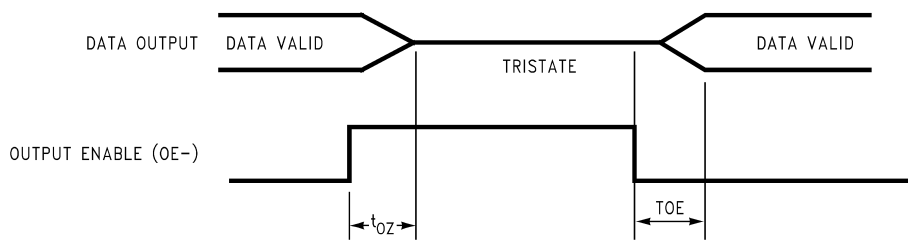

10102713

Data Output Enable

FIGURE 3. Data Output Timing



Timing Diagrams (Continued)

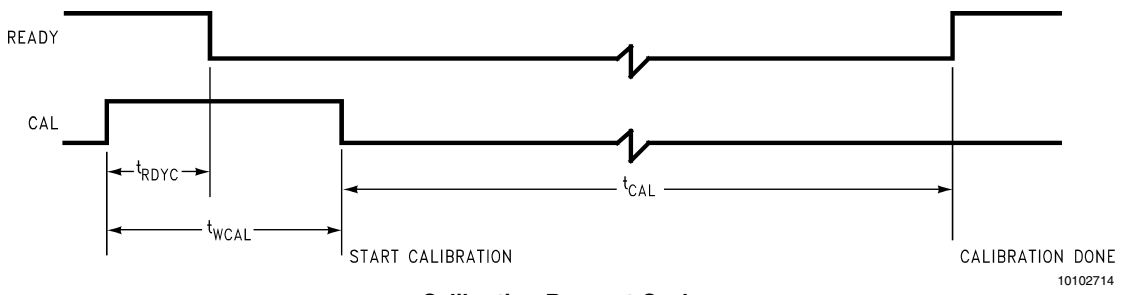

Calibration Request Cycle

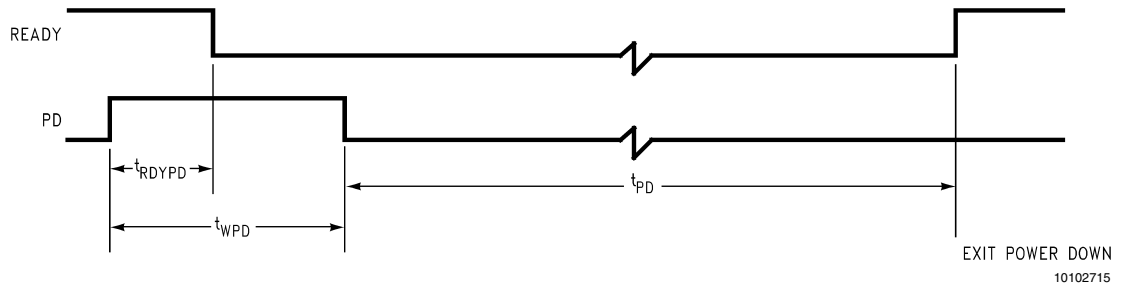

Power Down Request Cycle

FIGURE 4. Reset and Calibration Timing

**Typical Performance Characteristics** ( $V_A = V_D = V_{D\ I/O} = 5V$ ,  $f_{CLK} = 20\text{ MHz}$ , unless otherwise stated)

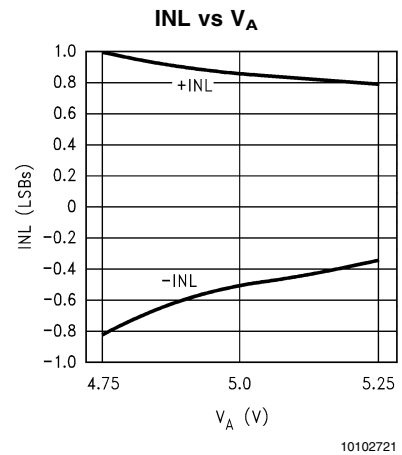
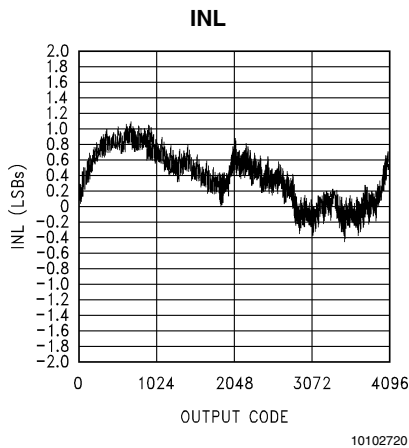
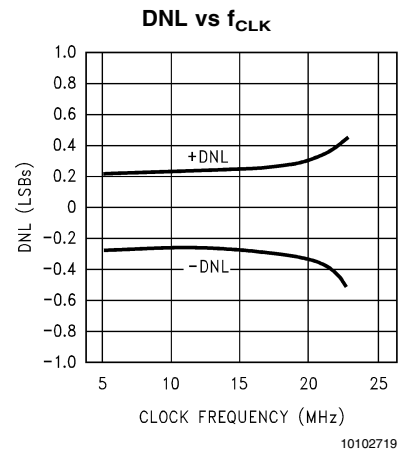
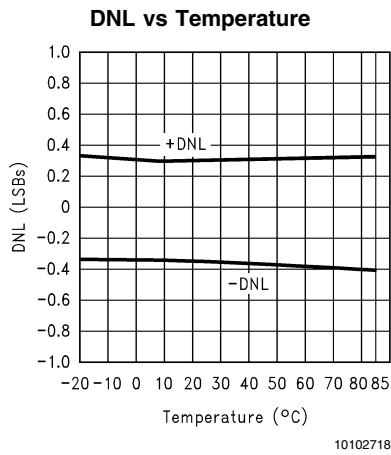
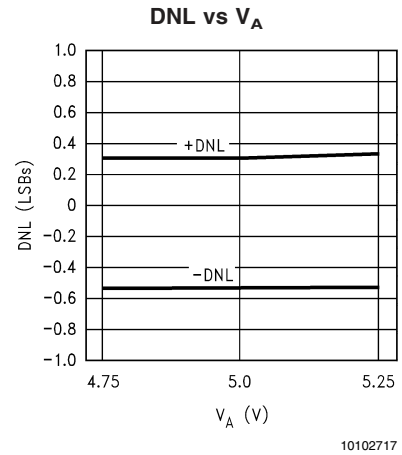
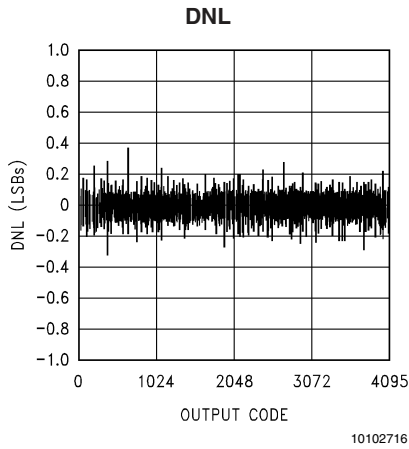

**Typical Performance Characteristics** ( $V_A = V_D = V_{D\ I/O} = 5V$ ,  $f_{CLK} = 20\text{ MHz}$ , unless otherwise stated) (Continued)

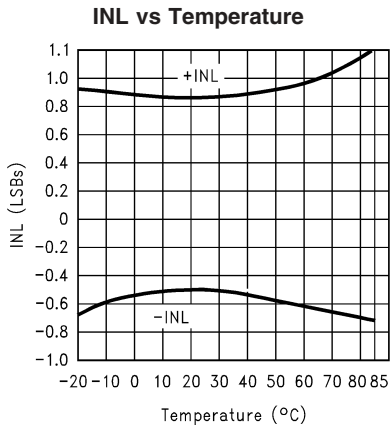

10102722

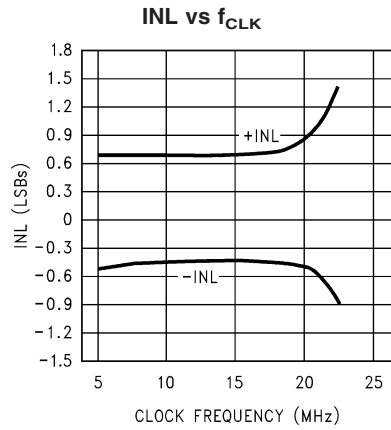

10102723

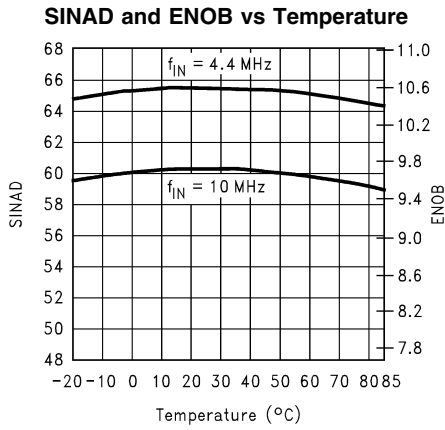

10102724

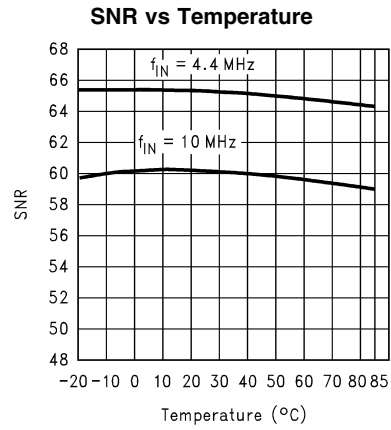

10102725

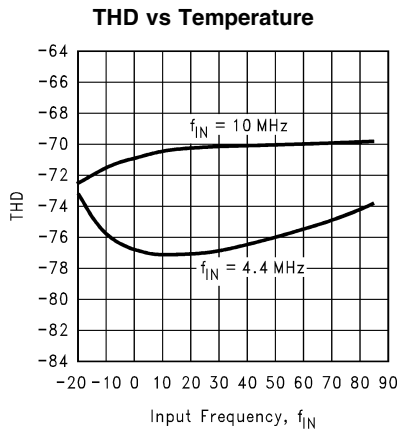

10102726

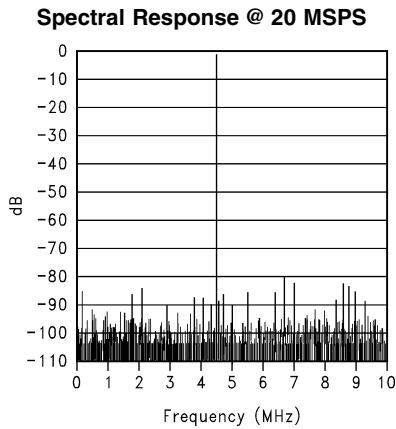

10102727

## Specification Definitions

**APERTURE JITTER** is the variation in aperture delay from sample to sample. Aperture jitter shows up as input noise.

**APERTURE DELAY** See Sampling Delay.

**CLOCK DUTY CYCLE** is the ratio of the time that the clock waveform is high to the total time for one clock cycle.

**CONVERSION LATENCY:** See PIPELINE DELAY.

**DIFFERENTIAL NON-LINEARITY (DNL)** is the measure of the maximum deviation from the ideal step size of 1 LSB.

**EFFECTIVE NUMBER OF BITS (ENOB, or EFFECTIVE BITS)** is another method of specifying Signal-to-Noise and Distortion or SINAD. ENOB is defined as  $(\text{SINAD} - 1.76)/6.02$  and says that the converter is equivalent to a perfect ADC of this (ENOB) number of bits.

**FULL SCALE ERROR** is the difference between the input voltage ( $V_{\text{IN}+} - V_{\text{IN}-}$ ) just causing a transition to positive full scale and  $V_{\text{REF-}} - 1.5 \text{ LSB}$ , where  $V_{\text{REF}}$  is  $(V_{\text{REF+}} - V_{\text{REF-}})$ .

**FULL POWER BANDWIDTH** is a measure of the frequency at which the reconstructed output fundamental drops 3 dB below its low frequency value for a full scale input.

**INTEGRAL NON-LINEARITY (INL)** is a measure of the deviation of each individual code from a line drawn from negative full scale ( $1/2$  LSB below the first code transition) through positive full scale (the last code transition). The deviation of any given code from this straight line is measured from the center of that code value. The end point test method is used. INL is commonly measured at rated clock frequency with a ramp input.

**OFFSET ERROR** is the difference between the ideal LSB transition to the actual transition point. The LSB transition should occur when  $V_{\text{IN}+} = V_{\text{IN}-}$ .

**PIPELINE DELAY (LATENCY)** is the number of clock cycles between initiation of conversion and the availability of that same conversion result at the output. New data is available at every clock cycle, but the data lags the conversion by the pipeline delay plus the Output Delay.

**SAMPLING (APERTURE) DELAY** is the time after the edge of the clock to when the input signal is acquired or held for conversion.

**SIGNAL TO NOISE RATIO (SNR)** is the ratio, expressed in dB, of the rms value of the input signal to the rms value of the sum of all other spectral components below one-half the sampling frequency, not including harmonics or dc.

**SIGNAL TO NOISE PLUS DISTORTION (S/N+D or SINAD)** is the ratio, expressed in dB, of the rms value of the input signal to the rms value of all of the other spectral components below half the clock frequency, including harmonics but excluding dc.

**SPURIOUS FREE DYNAMIC RANGE (SFDR)** is the difference, expressed in dB, between the rms values of the input signal and the peak spurious signal, where a spurious signal is any signal present in the output spectrum that is not present at the input.

**TOTAL HARMONIC DISTORTION (THD)** is the ratio, expressed in dB or dBc, of the rms total of the first six harmonic components to the rms value of the input signal.

**ZERO SCALE OFFSET ERROR** is the difference between the ideal input voltage ( $1/2$  LSB) and the actual input voltage that just causes a transition from an output code of zero to an output code of one.

**ZERO ERROR** See Zero Scale Offset Error.

## Functional Description

The ADC12281 is a monolithic CMOS analog-to-analog converter capable of converting single-ended analog input signals into 12-bit digital words at 20 megasamples per second (MSPS). This device utilizes a proprietary pipeline architecture and algorithm to minimize die size and power dissipation. The ADC12281 uses self-calibration and digital error correction to maintain accuracy and performance over temperature and a single-ended to differential conversion circuit to ease input interfacing while achieving differential input performance.

The ADC12281 has an input signal sample-and-hold amplifier and internal reference buffer. The analog input and the reference voltage are converted to differential signals for internal use. Using differential signals in the analog conversion core reduces crosstalk and noise pickup from the digital section and power supply.

The pipeline conversion core has 15 sequential signal processing stages. Each stage receives an analog signal from the previous stage (called "residue") and produces a 1-bit digital output that is sent to the digital correction module. At each stage the analog signal received from the previous stage is compared to an internally-generated reference level. It is then amplified by a factor of 2, and, depending on the output of the comparator, the internal reference signal may be subtracted from the amplifier output. This produces the residue that is passed to the next stage.

The calibration module is activated at power-on or by user request. During calibration the conversion core is put into a special mode of operation in order to determine inherent errors in the analog conversion blocks such as op amp offsets, comparator offsets, capacitor mismatches, etc. The calibration procedure determines coefficients for each digital output bit from the conversion core and stores these coefficients in on-chip RAM. The digital correction module uses the coefficients in RAM to convert the raw data bits from the conversion core into the 12-bit digital output code.

## Applications Information

### 1.0 ANALOG INPUTS

The analog inputs of the ADC12281 are the reference input ( $V_{\text{REF}}$ ) and the signal input ( $V_{\text{IN}}$ ).

#### Reference Input

The  $V_{\text{REF}}$  input must be driven from an accurate, stable reference voltage source between 1.8V and 2.2V and bypassed to a clean, low-noise ground with a monolithic ceramic capacitor (nominally 0.01  $\mu\text{F}$ ).

#### Analog Signal Input

This analog input is a switch followed by an integrator. The input capacitance changes with the clock level, appearing as 10 pF when the clock is low, and 15 pF when the clock is high. Since a dynamic capacitance is more difficult to drive than is a fixed capacitance, choose an amplifier that can drive this type of load. The CLC409 has been found to be a good device to drive the ADC12281. Do not drive the input beyond the supply rails.

The  $V_{\text{IN}}$  input must be driven with a low impedance signal source that does not add any distortion to the input signal. The ground reference for the  $V_{\text{IN}}$  input is the  $V_{\text{IN COM}}$  pin. The  $V_{\text{IN COM}}$  pin should be connected to a clean point in the



## Applications Information (Continued)

### 3.0 OUTPUTS

The ADC12281 has three analog outputs: reference output voltages  $V_{RN}$ ,  $V_{RM}$ , and  $V_{RP}$ . There are 14 digital outputs: 12 Data Output pins, OR (Over-range) and Ready.

**The reference output voltages** are made available only for the purpose of bypassing with capacitors to a clean analog ground. The recommended bypass capacitors are 0.1  $\mu\text{F}$  ceramic chip capacitors.

**DO NOT LOAD** reference bypass pins 30, 31 or 32.

**The OR output** goes low to indicate the presence of valid data at the output data lines. The signal will go high when the analog input is above the  $V_{REF}$  input or below GND.

**The READY output**, when at a logic high, indicates that the ADC12281 is ready to convert. This output is at a logic low during a calibration cycle and when the ADC12281 is in the power down mode.

**The Data Outputs** are TTL/CMOS compatible. The output data format is 12 bits straight binary. The  $V_D$  I/O provides power for the output driver and may be operated from a supply in the range of 3.0V to the  $V_D$  supply (nominal 5V). This can simplify interfacing to 3.0V devices and systems.

Powering the  $V_D$  I/O from 3V will also reduce power consumption and noise generation due to output switching. **DO NOT operate the  $V_D$  I/O at a voltage higher than  $V_D$  or  $V_A$ !**

Also helpful in minimizing noise due to output switching is to minimize the currents at the digital outputs. This can be done by connecting buffers between the ADC outputs and any other circuitry. Only one buffer should be connected to each output. Additionally, inserting series resistors of 47 $\Omega$  to 56 $\Omega$  right at the digital outputs, close to the ADC pins, will isolate the outputs from other circuitry and limit output currents.

### 4.0 POWER SUPPLY CONSIDERATIONS

Each power pin should be bypassed with a parallel combination of a 10  $\mu\text{F}$  capacitor and a 0.1  $\mu\text{F}$  ceramic chip capacitor. The chip capacitors should be within 1/2 centimeter of the power pins. Leadless chip capacitors are preferred because they provide low lead inductance.

The converter's digital logic supply ( $V_D$ ) should be well isolated from the supply that is used for other digital circuitry on the board. A common power supply should be used for both  $V_A$  (analog supply) and  $V_D$  (digital supply), and each of these supply pins should be separately bypassed with a 0.1  $\mu\text{F}$  ceramic capacitor and a low ESR 10  $\mu\text{F}$  electrolytic capaci-

tor. A ferrite bead or inductor should be used between  $V_A$  and  $V_D$  to prevent noise coupling from the digital supply into the analog circuit.

$V_D$  I/O is the power pin for the output buffers. This pin may be supplied with a potential between 2.7V and  $V_D$ . This makes it easy to interface the ADC12281 with 3V or 5V logic families.

The voltage at  $V_D$  I/O should never exceed the voltage at either  $V_A$  or  $V_D$ . All power supplies connected to the device should be applied simultaneously.

As is the case with all high speed converters, the ADC12281 is sensitive to power supply noise. Accordingly, the noise on the analog supply pin should be minimized.

### 5.0 LAYOUT AND GROUNDING

Proper grounding and proper routing of all signals are essential to ensure accurate conversion. Separate analog and digital ground planes that are connected beneath the ADC12281 are required to achieve specified performance. The analog and digital grounds may be in the same layer, but should be separated from each other and should never overlap each other. Separation between the analog and digital ground planes should be at least 1/8 inch, were possible.

The ground return for the digital supply (DGND I/O) carries the ground current for the output drivers. The output current can exhibit high transients that could add noise to the conversion process. To prevent this from happening, the DGND I/O pin should NOT be connected to system ground in close proximity to any of the ADC12281's ground pins.

Capacitive coupling between the typically noisy digital ground plane and the sensitive analog circuitry can lead to poor performance that may seem impossible to isolate and remedy. The solution is to keep the analog circuitry separated from the digital circuitry and from the digital ground plane.

Digital circuits create substantial supply and ground current transients. The logic noise thus generated could have significant impact upon system noise performance. The best logic family to use in systems with A/D converters is one which employs non-saturating transistor designs, or has low noise characteristics, such as the 74LS, 74HC(T) and 74AC(T)Q families. The worst noise generators are logic families that draw the largest supply current transients during clock or signal edges, like the 74F and the 74AC(T) families.

## Applications Information (Continued)

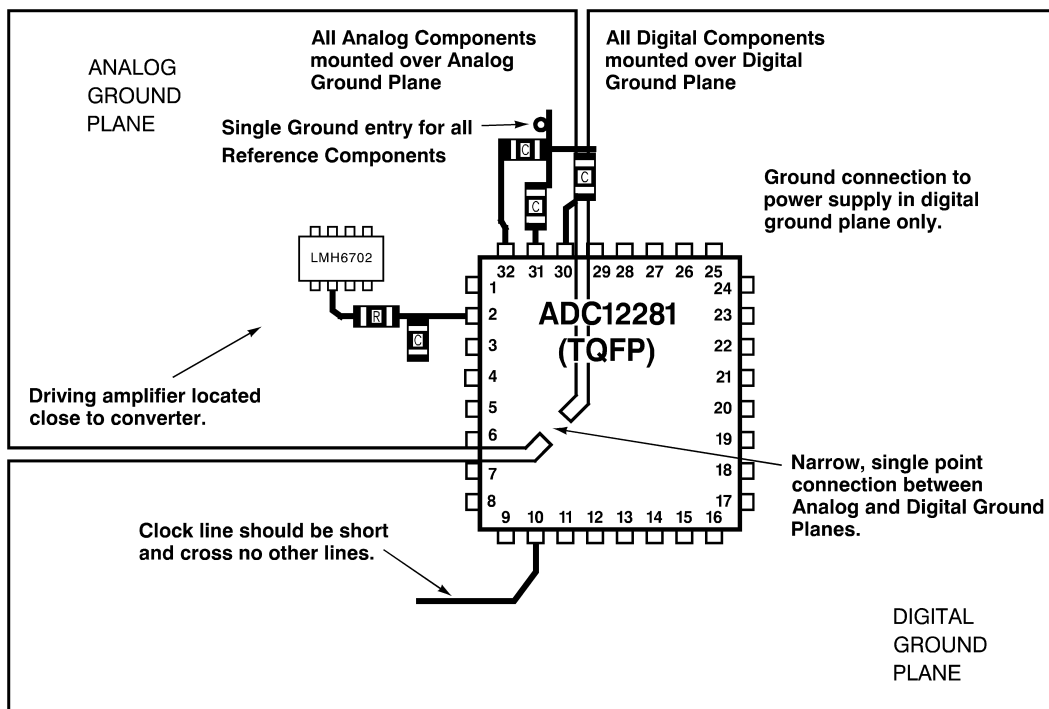

10102729

FIGURE 6. Example of a Suitable Layout

### 6.0 COMMON APPLICATION PITFALLS

**Driving the inputs (analog or digital) beyond the power supply rails.** For proper operation, all inputs should not go more than 100 mV beyond the supply rails (more than 100 mV below the ground pins or 100 mV above the supply pins). Exceeding these limits on even a transient basis may cause faulty or erratic operation. It is not uncommon for high speed digital circuits (e.g., 74F and 74AC devices) to exhibit overshoot or undershoot that goes above the power supply or more than a volt below ground. A resistor of about 50Ω to 100Ω in series with the offending digital input will eliminate the problem.

Do not allow input voltages to exceed the supply voltage during power up.

Be careful not to overdrive the inputs of the ADC12281 with a device that is powered from supplies outside the range of the ADC12281 supply. Such practice may lead to conversion inaccuracies and even to device damage.

**Attempting to drive a high capacitance digital data bus.** The more capacitance the output drivers must charge for each conversion, the more instantaneous digital current flows through  $V_D$  I/O and DGND I/O. These large charging current spikes can couple into the analog circuitry, degrading dynamic performance. Adequate bypassing and maintaining separate analog and digital ground planes will reduce this problem. The digital data outputs should be buffered (with

74ACQ541, for example). Dynamic performance can also be improved by adding series resistors at each digital output, close to the ADC12281, which reduces the energy coupled back into the converter output pins by limiting the output current. A reasonable value for these resistors is 47Ω.

**Using an inadequate amplifier to drive the analog input.** As explained in Section 1.2, the capacitance seen at the input alternates between 12 pF and 28 pF, depending upon the phase of the clock. This dynamic load is more difficult to drive than is a fixed capacitance.

If the amplifier exhibits overshoot, ringing, or any evidence of instability, even at a very low level, it will degrade performance. The CLC409 has been found to be a good amplifier to drive the ADC12281. A small series resistor at the amplifier output, followed by a capacitor to ground (as shown in Figure 5), will improve performance.

**Operating with the reference pins outside of the specified range.** As mentioned in Section 1.1,  $V_{REF}$  should be in the range of  $1.8V \leq V_{REF} \leq 2.2V$ . Operating outside of these limits could lead to output distortion.

**Using a clock source with excessive jitter, using excessively long clock signal trace, or having other signals coupled to the clock signal trace.** This will cause the sampling interval to vary, causing excessive output noise and a reduction in SNR and SINAD performance.

# ADC12281 12-Bit, 20 MSPS Single-Ended Input, Pipelined A/D Converter

## Physical Dimensions inches (millimeters) unless otherwise noted

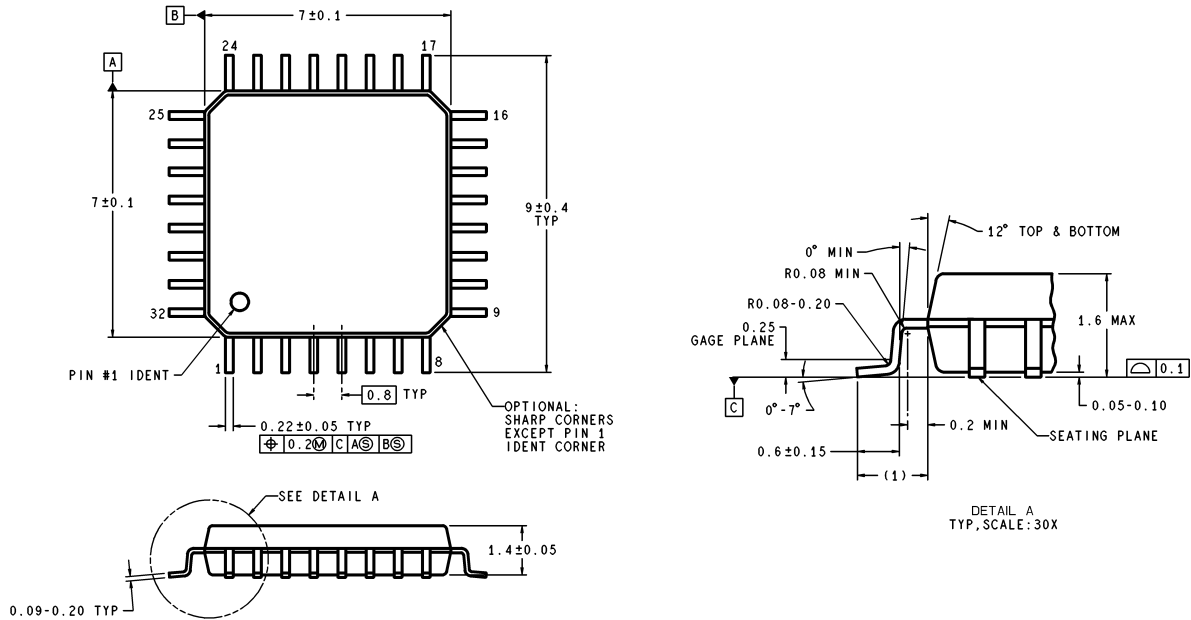

DIMENSIONS ARE IN MILLIMETERS

VBE32A (Rev E)

**32-Lead TQFP Package**  
**Order Number ADC12281CIVT**  
**NS Package Number VBE32A**

### LIFE SUPPORT POLICY

NATIONAL'S PRODUCTS ARE NOT AUTHORIZED FOR USE AS CRITICAL COMPONENTS IN LIFE SUPPORT DEVICES OR SYSTEMS WITHOUT THE EXPRESS WRITTEN APPROVAL OF THE PRESIDENT AND GENERAL COUNSEL OF NATIONAL SEMICONDUCTOR CORPORATION. As used herein:

1. Life support devices or systems are devices or systems which, (a) are intended for surgical implant into the body, or (b) support or sustain life, and whose failure to perform when properly used in accordance with instructions for use provided in the labeling, can be reasonably expected to result in a significant injury to the user.
2. A critical component is any component of a life support device or system whose failure to perform can be reasonably expected to cause the failure of the life support device or system, or to affect its safety or effectiveness.



**National Semiconductor Corporation**  
Americas  
Email: support@nsc.com

www.national.com

**National Semiconductor Europe**  
Fax: +49 (0) 180-530 85 86  
Email: europe.support@nsc.com  
Deutsch Tel: +49 (0) 69 9508 6208  
English Tel: +44 (0) 870 24 0 2171  
Français Tel: +33 (0) 1 41 91 8790

**National Semiconductor Asia Pacific Customer Response Group**  
Tel: 65-2544466  
Fax: 65-2504466  
Email: ap.support@nsc.com

**National Semiconductor Japan Ltd.**  
Tel: 81-3-5639-7560  
Fax: 81-3-5639-7507