

# HM514260C Series HM51S4260C Series

262,144-word × 16-bit Dynamic Random Access Memory

# HITACHI

ADE-203-260A (Z)

Rev. 1.0

Jun. 12, 1995

## Description

The Hitachi HM51(S)4260C is CMOS dynamic RAM organized as 262,144-word × 16-bit. HM51(S)4260C has realized higher density, higher performance and various functions by employing 0.8 μm CMOS process technology and some new CMOS circuit design technologies. The HM51(S)4260C offers fast page mode as a high speed access mode. Multiplexed address input permits the HM51(S)4260C to be packaged in standard 400-mil 40-pin plastic SOJ and standard 400-mil 44-pin plastic TSOPII. Internal refresh timer enables HM51S4260C self refresh operation.

## Features

- Single 5 V (±10%) (HM51(S)4260C-6/7/8)  
    (±5%) (HM51(S)4260C-6R)
- High speed
  - Access time: 60 ns/70 ns/80 ns (max)
- Low power dissipation
  - Active mode: 825 mW/788 mW/770 mW/688 mW (max)
  - Standby mode: 11 mW (max) (HM51(S)4260C-6/7/8)  
    10.5 mW (max) (HM51(S)4260C-6R)  
    1.1 mW (max) (L-version) (HM51(S)4260C-6/7/8)  
    1.05 mW (max) (L-version) (HM51(S)4260C-6R)
- Fast page mode capability
- 512 refresh cycles: 8 ms  
    128 ms (L-version)
- 2  $\overline{\text{CAS}}$ -byte control
- 2 variations of refresh
  - $\overline{\text{RAS}}$ -only refresh
  - $\overline{\text{CAS}}$ -before- $\overline{\text{RAS}}$  refresh
- Battery backup operation (L-version)
- Self refresh operation (HM51S4260C)



---

## HM514260C, HM51S4260C Series

---

### Ordering Information

Type No.	Access Time	Package
HM514260CJ-6	60 ns	400-mill 40-pin plastic SOJ (CP-40DA)
HM514260CJ-6R	60 ns	
HM514260CJ-7	70 ns	
HM514260CJ-8	80 ns	
HM514260CLJ-6	60 ns	
HM514260CLJ-6R	60 ns	
HM514260CLJ-7	70 ns	
HM514260CLJ-8	80 ns	
HM51S4260CJ-6	60 ns	
HM51S4260CJ-6R	60 ns	
HM51S4260CJ-7	70 ns	
HM51S4260CJ-8	80 ns	
HM51S4260CLJ-6	60 ns	
HM51S4260CLJ-6R	60 ns	
HM51S4260CLJ-7	70 ns	
HM51S4260CLJ-8	80 ns	
HM514260CTT-6	60 ns	400-mill 44-pin plastic TSOP II (TTP-44/40DB)
HM514260CTT-6R	60 ns	
HM514260CTT-7	70 ns	
HM514260CTT-8	80 ns	
HM514260CLTT-6	60 ns	
HM514260CLTT-6R	60 ns	
HM514260CLTT-7	70 ns	
HM514260CLTT-8	80 ns	
HM51S4260CTT-6	60 ns	
HM51S4260CTT-6R	60 ns	
HM51S4260CTT-7	70 ns	
HM51S4260CTT-8	80 ns	
HM51S4260CLTT-6	60 ns	
HM51S4260CLTT-6R	60 ns	
HM51S4260CLTT-7	70 ns	
HM51S4260CLTT-8	80 ns	

## HM514260C, HM51S4260C Series

### Pin Arrangement

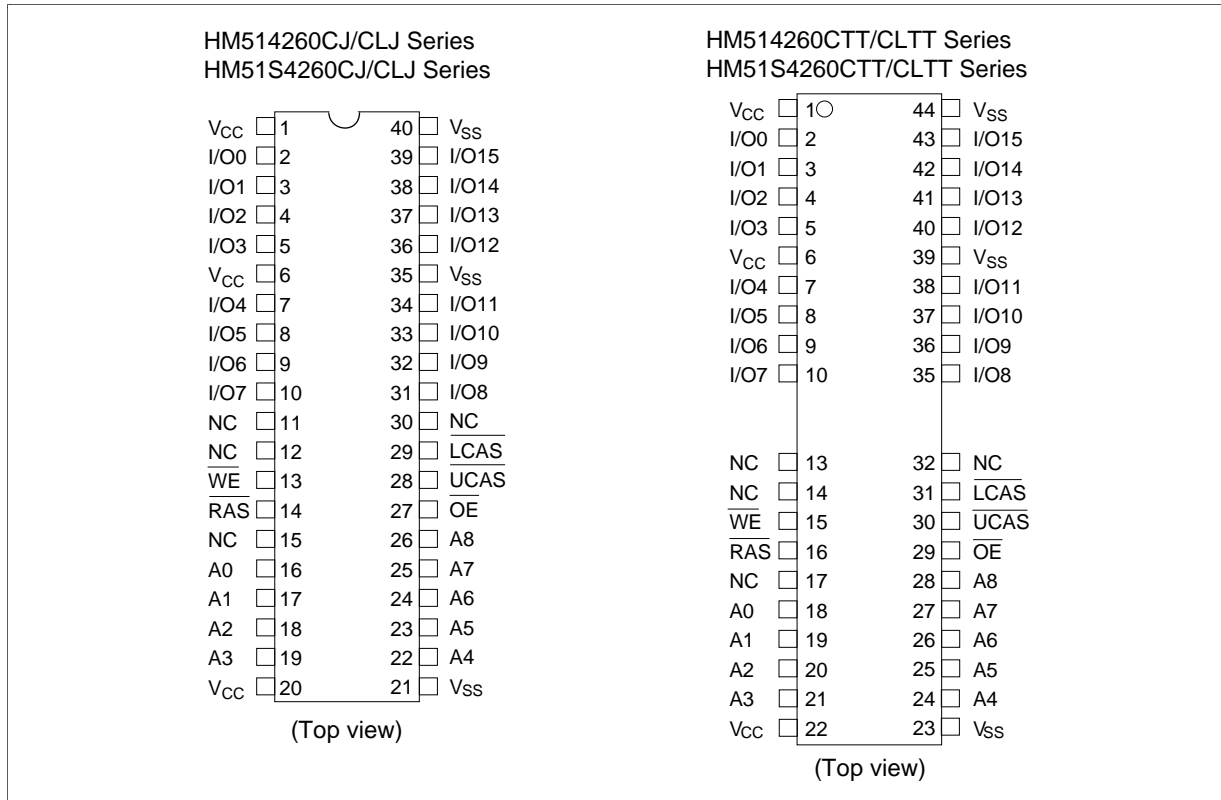

### Pin Description

Pin Name	Function
A0 to A8	Address input –Row address      A0 to A8 –Column address    A0 to A8 –Refresh address    A0 to A8
I/O0 to I/O15	Data-in/data-out
$\overline{\text{RAS}}$	Row address strobe
$\overline{\text{UCAS}}$ , $\overline{\text{LCAS}}$	Column address strobe
$\overline{\text{WE}}$	Read/write enable
$\overline{\text{OE}}$	Output enable
$V_{\text{CC}}$	Power (+5 V)
$V_{\text{SS}}$	Ground
NC	No connection

# HM514260C, HM51S4260C Series

## Block Diagram

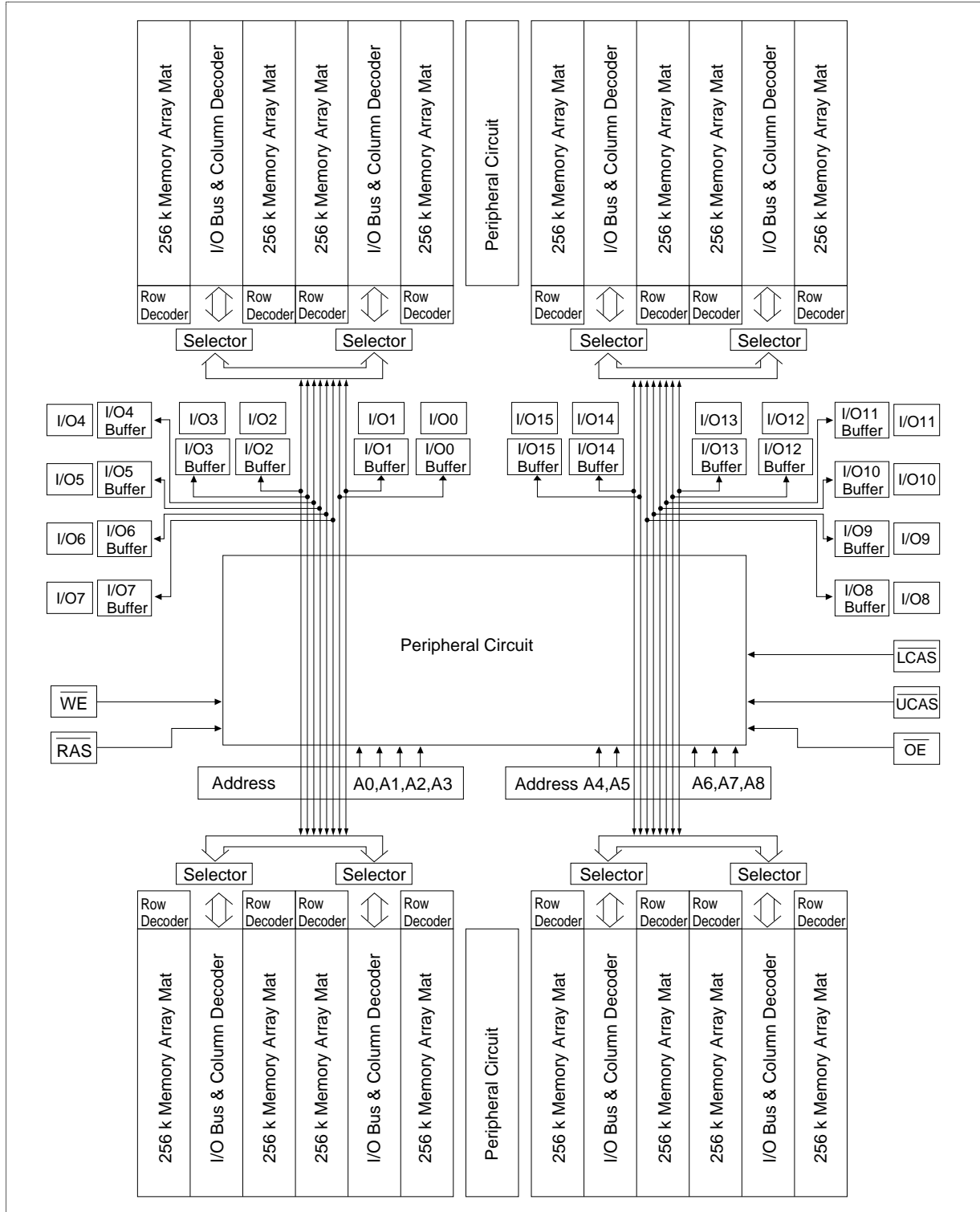

## HM514260C, HM51S4260C Series

### Operation Mode

The HM51(S)4260C series has the following 11 operation modes.

1. Read cycle
2. Early write cycle
3. Delayed write cycle
4. Read- modify-write cycle
5.  $\overline{\text{RAS}}$ -only refresh cycle
6.  $\overline{\text{CAS}}$ -before- $\overline{\text{RAS}}$  refresh cycle
7. Self refresh cycle(HM51S4260C)
8. Fast page mode read cycle
9. Fast page mode early write cycle
10. Fast page mode delayed write cycle
11. Fast page mode read- modify-write cycle

#### Inputs

$\overline{\text{RAS}}$	$\overline{\text{LCAS}}$	$\overline{\text{UCAS}}$	$\overline{\text{WE}}$	$\overline{\text{OE}}$	Output	Operation
H	H	H	D	D	Open	Standby
H	L	L	H	L	Valid	Standby
L	L	L	H	L	Valid	Read cycle
L	L	L	L* <sup>2</sup>	D	Open	Early write cycle
L	L	L	L* <sup>2</sup>	H	Undefined	Delayed write cycle
L	L	L	H to L	L to H	Valid	Read-modify-write cycle
L	H	H	D	D	Open	$\overline{\text{RAS}}$ -only refresh cycle
H to L	H	L	D	D	Open	$\overline{\text{CAS}}$ -before- $\overline{\text{RAS}}$ refresh cycle
	L	H				Self refresh cycle (HM51S4260C)
	L	L				
L	H to L	H to L	H	L	Valid	Fast page mode read cycle
L	H to L	H to L	L* <sup>2</sup>	D	Open	Fast page mode early write cycle
L	H to L	H to L	L* <sup>2</sup>	H	Undefined	Fast page mode delayed write cycle
L	H to L	H to L	H to L	L to H	Valid	Fast page mode read-modify-write cycle
L	L	L	H	H	Open	Read cycle (Output disabled)

Notes: 1. H: High(inactive) L: Low(active) D: H or L

2.  $t_{\text{WCS}} \geq 0$  ns      Early write cycle  
 $t_{\text{WCS}} < 0$  ns      Delayed write cycle

3. Mode is determined by the OR function of the  $\overline{\text{UCAS}}$  and  $\overline{\text{LCAS}}$ . (Mode is set by the earliest of  $\overline{\text{UCAS}}$  and  $\overline{\text{LCAS}}$  active edge and reset by the latest of  $\overline{\text{UCAS}}$  and  $\overline{\text{LCAS}}$  inactive edge.) However write OPERATION and output HIZ control are done independently by each  $\overline{\text{UCAS}}$ ,  $\overline{\text{LCAS}}$ .  
ex. if  $\overline{\text{RAS}} = \text{H to L}$ ,  $\overline{\text{LCAS}} = \text{L}$ ,  $\overline{\text{UCAS}} = \text{H}$ , then  $\overline{\text{CAS}}$ -before- $\overline{\text{RAS}}$  refresh cycle is selected.

---

## HM514260C, HM51S4260C Series

---

### Absolute Maximum Ratings

Parameter	Symbol	Value	Unit
Voltage on any pin relative to $V_{SS}$	$V_T$	-1.0 to +7.0	V
Supply voltage relative to $V_{SS}$	$V_{CC}$	-1.0 to +7.0	V
Short circuit output current	$I_{out}$	50	mA
Power dissipation	$P_T$	1.0	W
Operating temperature	$T_{opr}$	0 to +70	°C
Storage temperature	$T_{stg}$	-55 to +125	°C

### Recommended DC Operating Conditions ( $T_a = 0$ to +70°C)<sup>\*2</sup>

Parameter	Symbol	Min	Typ	Max	Unit	Notes
Supply voltage	$V_{SS}$	0	0	0	V	2
	$V_{CC}$ (HM51(S)4260C-6/7/8)	4.5	5.0	5.5	V	1, 2
	$V_{CC}$ (HM51(S)4260C-6R)	4.75	5.0	5.25	V	1, 2
Input high voltage	$V_{IH}$	2.4	—	6.5	V	1
Input low voltage	$V_{IL}$	-1.0	—	0.8	V	1

Notes: 1. All voltage referred to  $V_{SS}$ .

2. The supply voltage with all  $V_{CC}$  pins must be on the same level.  
The supply voltage with all  $V_{SS}$  pins must be on the same level.

## HM514260C, HM51S4260C Series

**DC Characteristics** (Ta = 0 to 70°C, V<sub>CC</sub> = 5 V ±5%, V<sub>SS</sub> = 0 V) (HM51(S)4260C-6R)  
 (Ta = 0 to 70°C, V<sub>CC</sub> = 5 V ±10%, V<sub>SS</sub> = 0 V)  
 (HM51(S)4260C-6/7/8)

### HM514260C, HM51S4260C

Parameter	Symbol	-6/-6R		-7		-8		Unit	Test Conditions
		Min	Max	Min	Max	Min	Max		
Operating current <sup>1,2</sup>	I <sub>CC1</sub>	—	150	—	140	—	125	mA	RAS, UCAS or LCAS cycling t <sub>RC</sub> = min
Standby current	I <sub>CC2</sub>	—	2	—	2	—	2	mA	TTL interface RAS, UCAS, LCAS = V <sub>IH</sub> Dout = High-Z
		—	1	—	1	—	1	mA	CMOS interface RAS, UCAS, LCAS, WE, OE ≥ V <sub>CC</sub> - 0.2 V Dout = High-Z
Standby current (L-version)	I <sub>CC2</sub>	—	200	—	200	—	200	μA	CMOS interface RAS, UCAS, LCAS, OE, WE ≥ V <sub>CC</sub> - 0.2 V Dout = High-Z
RAS-only refresh current <sup>2</sup>	I <sub>CC3</sub>	—	140	—	130	—	110	mA	t <sub>RC</sub> = min
Standby current <sup>1</sup>	I <sub>CC5</sub>	—	5	—	5	—	5	mA	RAS = V <sub>IH</sub> , UCAS or LCAS = V <sub>IL</sub> Dout = enable
CAS-before-RAS refresh current <sup>2</sup>	I <sub>CC6</sub>	—	140	—	130	—	110	mA	t <sub>RC</sub> = min
Fast page mode current <sup>1,3</sup>	I <sub>CC7</sub>	—	150	—	130	—	120	mA	t <sub>PC</sub> = min
Battery backup current <sup>4</sup> (Standby with CBR refresh) (L-version)	I <sub>CC10</sub>	—	300	—	300	—	300	μA	Standby: CMOS interface Dout = High-Z CBR refresh: t <sub>RC</sub> = 250 μs t <sub>RAS</sub> ≤ 1 μs, UCAS, LCAS = V <sub>IL</sub> WE, OE = V <sub>IH</sub>
Self-refresh mode current (HM51S4260C)	I <sub>CC11</sub>	—	1	—	1	—	1	mA	CMOS interface RAS, UCAS, LCAS ≤ 0.2 V, Dout = High-Z
Self-refresh mode current (HM51S4260CL)	I <sub>CC11</sub>	—	200	—	200	—	200	μA	CMOS interface RAS, UCAS, LCAS ≤ 0.2 V, Dout = High-Z

## HM514260C, HM51S4260C Series

**DC Characteristics** ( $T_a = 0$  to  $70^\circ\text{C}$ ,  $V_{CC} = 5\text{ V} \pm 5\%$ ,  $V_{SS} = 0\text{ V}$ ) (HM51(S)4260C-6R)  
 ( $T_a = 0$  to  $70^\circ\text{C}$ ,  $V_{CC} = 5\text{ V} \pm 10\%$ ,  $V_{SS} = 0\text{ V}$ )  
 (HM51(S)4260C-6/7/8) (cont)

### HM514260C, HM51S4260C

Parameter	Symbol	-6/-6R		-7		-8		Unit	Test Conditions
		Min	Max	Min	Max	Min	Max		
Input leakage current	$I_{LI}$	-10	10	-10	10	-10	10	$\mu\text{A}$	$0\text{ V} \leq V_{in} \leq 6.5\text{ V}$
Output leakage current	$I_{LO}$	-10	10	-10	10	-10	10	$\mu\text{A}$	$0\text{ V} \leq V_{out} \leq 6.5\text{ V}$ , Dout = disable
Output high voltage	$V_{OH}$	2.4	$V_{CC}$	2.4	$V_{CC}$	2.4	$V_{CC}$	V	High Iout = -5.0 mA
Output low voltage	$V_{OL}$	0	0.4	0	0.4	0	0.4	V	Low Iout = 4.2 mA

- Notes: 1.  $I_{CC}$  depends on output load condition when the device is selected.  $I_{CC}$  max is specified at the output open condition.  
 2. Address can be changed once or less while  $\overline{RAS} = V_{IL}$ .  
 3. Address can be changed once or less while  $\overline{UCAS}$  and  $\overline{LCAS} = V_{IH}$ .  
 4.  $V_{IH} \geq V_{CC} - 0.2\text{ V}$ ,  $0 \leq V_{IL} \leq 0.2\text{ V}$ , Address can be changed once or less while  $\overline{RAS} = V_{IL}$ .  
 5. All the  $V_{CC}$  pins shall be supplied with the same voltage. And all the  $V_{SS}$  pins shall be supplied with the same voltage.

**Capacitance** ( $T_a = +25^\circ\text{C}$ ,  $V_{CC} = 5\text{ V} \pm 5\%$ ) (HM51(S)4260C-6R)  
 ( $T_a = +25^\circ\text{C}$ ,  $V_{CC} = 5\text{ V} \pm 10\%$ ) (HM51(S)4260C-6/7/8)

Parameter	Symbol	Typ	Max	Unit	Notes
Input capacitance (Address)	$C_{I1}$	—	5	pF	1
Input capacitance (Clocks)	$C_{I2}$	—	7	pF	1
Output capacitance (Data-in, Data-out)	$C_{IO}$	—	10	pF	1, 2

- Notes: 1. Capacitance measured with Boonton Meter or effective capacitance measuring method.  
 2.  $\overline{UCAS}$  and  $\overline{LCAS} = V_{IH}$  to disable Dout



## HM514260C, HM51S4260C Series

**AC Characteristics** (Ta = 0 to 70°C, V<sub>CC</sub> = 5 V ±5%, V<sub>SS</sub> = 0 V)  
 (HM51(S)4260C-6R)\*1, \*14, \*15, \*17, \*18  
 (Ta = 0 to 70°C, V<sub>CC</sub> = 5 V ±10%, V<sub>SS</sub> = 0 V)  
 (HM51(S)4260C-6/7/8)\*1, \*14, \*15, \*17, \*18

### Test Conditions

- Input rise and fall time: 5 ns
  - Input timing reference levels: 0.8 V, 2.4 V
  - Input levels: 0 V, 3 V
- Output load: 2 TTL gate + C<sub>L</sub> (50 pF) (HM51(S)4260C-6R) (Including scope and jig)  
 2 TTL gate + C<sub>L</sub> (100 pF) (HM51(S)4260-6/7/8) (Including scope and jig)

### Read, Write, Read-Modify-Write and Refresh Cycles (Common Parameters)

HM514260C, HM51S4260C									
		-6/-6R		-7		-8			
Parameter	Symbol	Min	Max	Min	Max	Min	Max	Unit	Notes
Random read or write cycle time	t <sub>RC</sub>	110	—	130	—	150	—	ns	
$\overline{\text{RAS}}$ precharge time	t <sub>RP</sub>	40	—	50	—	60	—	ns	
$\overline{\text{RAS}}$ pulse width	t <sub>RAS</sub>	60	10000	70	10000	80	10000	ns	
$\overline{\text{CAS}}$ pulse width	t <sub>CAS</sub>	15	10000	20	10000	20	10000	ns	23
Row address setup time	t <sub>ASR</sub>	0	—	0	—	0	—	ns	
Row address hold time	t <sub>RAH</sub>	10	—	10	—	10	—	ns	
Column address setup time	t <sub>ASC</sub>	0	—	0	—	0	—	ns	19
Column address hold time	t <sub>CAH</sub>	15	—	15	—	15	—	ns	19
$\overline{\text{RAS}}$ to $\overline{\text{CAS}}$ delay time	t <sub>RCD</sub>	20	45	20	50	20	60	ns	8
$\overline{\text{RAS}}$ to column address delay time	t <sub>RAD</sub>	15	30	15	35	15	40	ns	9
$\overline{\text{RAS}}$ hold time	t <sub>RSH</sub>	15	—	20	—	20	—	ns	
$\overline{\text{CAS}}$ hold time	t <sub>CSH</sub>	60	—	70	—	80	—	ns	
$\overline{\text{CAS}}$ to $\overline{\text{RAS}}$ precharge time	t <sub>CRP</sub>	10	—	15	—	15	—	ns	20
$\overline{\text{OE}}$ to Din delay time	t <sub>ODD</sub>	15	—	20	—	20	—	ns	
$\overline{\text{OE}}$ delay time from Din	t <sub>DZO</sub>	0	—	0	—	0	—	ns	
$\overline{\text{CAS}}$ setup time from Din	t <sub>DZC</sub>	0	—	0	—	0	—	ns	
Transition time (rise and fall)	t <sub>T</sub>	3	50	3	50	3	50	ns	7
Refresh period	t <sub>REF</sub>	—	8	—	8	—	8	ms	
Refresh period (L-version)	t <sub>REF</sub>	—	128	—	128	—	128	ms	

## HM514260C, HM51S4260C Series

### Read Cycle

HM514260C, HM51S4260C									
		-6/-6R		-7		-8			
Parameter	Symbol	Min	Max	Min	Max	Min	Max	Unit	Notes
Access time from $\overline{\text{RAS}}$	$t_{\text{RAC}}$	—	60	—	70	—	80	ns	2, 3
Access time from $\overline{\text{CAS}}$	$t_{\text{CAC}}$	—	15	—	20	—	20	ns	3, 4, 13
Access time from address	$t_{\text{AA}}$	—	30	—	35	—	40	ns	3, 5, 13
Access time from $\overline{\text{OE}}$	$t_{\text{OAC}}$	—	15	—	20	—	20	ns	23
Read command setup time	$t_{\text{RCS}}$	0	—	0	—	0	—	ns	19
Read command hold time to $\overline{\text{CAS}}$	$t_{\text{RCH}}$	0	—	0	—	0	—	ns	16, 19
Read command hold time to $\overline{\text{RAS}}$	$t_{\text{RRH}}$	0	—	0	—	0	—	ns	16
Column address to $\overline{\text{RAS}}$ lead time	$t_{\text{RAL}}$	30	—	35	—	40	—	ns	
Output buffer turn-off time	$t_{\text{OFF1}}$	0	15	0	15	0	15	ns	6
Output buffer turn-off to $\overline{\text{OE}}$	$t_{\text{OFF2}}$	0	15	0	15	0	15	ns	6
$\overline{\text{CAS}}$ to Din delay time	$t_{\text{CDD}}$	15	—	15	—	15	—	ns	

### Write Cycle

HM514260C, HM51S4260C									
		-6/-6R		-7		-8			
Parameter	Symbol	Min	Max	Min	Max	Min	Max	Unit	Notes
Write command setup time	$t_{\text{WCS}}$	0	—	0	—	0	—	ns	10, 19
Write command hold time	$t_{\text{WCH}}$	15	—	15	—	15	—	ns	19
Write command pulse width	$t_{\text{WP}}$	10	—	10	—	10	—	ns	
Write command to $\overline{\text{RAS}}$ lead time	$t_{\text{RWL}}$	20	—	20	—	20	—	ns	
Write command to $\overline{\text{CAS}}$ lead time	$t_{\text{CWL}}$	20	—	20	—	20	—	ns	21
Data-in setup time	$t_{\text{DS}}$	0	—	0	—	0	—	ns	11
Data-in hold time	$t_{\text{DH}}$	15	—	15	—	15	—	ns	11
$\overline{\text{CAS}}$ to $\overline{\text{OE}}$ delay time	$t_{\text{COD}}$	—	0	—	0	—	0	ns	23

## HM514260C, HM51S4260C Series

### Read-Modify-Write Cycle

HM514260C, HM51S4260C									
-6/-6R      -7      -8									
Parameter	Symbol	Min	Max	Min	Max	Min	Max	Unit	Notes
Read-modify-write cycle time	$t_{RWC}$	150	—	180	—	200	—	ns	
$\overline{RAS}$ to $\overline{WE}$ delay time	$t_{RWD}$	80	—	95	—	105	—	ns	10
$\overline{CAS}$ to $\overline{WE}$ delay time	$t_{CWD}$	35	—	45	—	45	—	ns	10
Column address to $\overline{WE}$ delay time	$t_{AWD}$	50	—	60	—	65	—	ns	10, 13
$\overline{OE}$ hold time from $\overline{WE}$	$t_{OEH}$	15	—	20	—	20	—	ns	

### Refresh Cycle

HM514260C, HM51S4260C									
-6/-6R      -7      -8									
Parameter	Symbol	Min	Max	Min	Max	Min	Max	Unit	Note
$\overline{CAS}$ setup time (CBR refresh cycle)	$t_{CSR}$	10	—	10	—	10	—	ns	19
$\overline{CAS}$ hold time (CBR refresh cycle)	$t_{CHR}$	10	—	10	—	10	—	ns	20
$\overline{RAS}$ precharge to $\overline{CAS}$ hold time	$t_{RPC}$	10	—	10	—	10	—	ns	19
$\overline{CAS}$ precharge time in normal mode	$t_{CPN}$	10	—	10	—	10	—	ns	22

### Fast Page Mode Cycle

HM514260C, HM51S4260C									
-6/-6R      -7      -8									
Parameter	Symbol	Min	Max	Min	Max	Min	Max	Unit	Notes
Fast page mode cycle time	$t_{PC}$	40	—	45	—	50	—	ns	
Fast page mode $\overline{CAS}$ precharge time	$t_{CP}$	10	—	10	—	10	—	ns	22
Fast page mode $\overline{RAS}$ pulse width	$t_{RASC}$	—	100000	—	100000	—	100000	ns	12
Access time from $\overline{CAS}$ precharge	$t_{ACP}$	—	35	—	40	—	45	ns	3, 13, 20
$\overline{RAS}$ hold time from $\overline{CAS}$ precharge	$t_{RHCP}$	35	—	40	—	45	—	ns	
Fast page mode read-modify-write cycle $\overline{CAS}$ precharge to $\overline{WE}$ delay time	$t_{CPW}$	55	—	65	—	70	—	ns	
Fast page mode read-modify-write cycle time	$t_{PCM}$	80	—	95	—	100	—	ns	

## HM514260C, HM51S4260C Series

### Self refresh Mode

Parameter	Symbol	HM51S4260C						Unit	Notes
		-6/-6R		-7		-8			
		Min	Max	Min	Max	Min	Max		
$\overline{\text{RAS}}$ pulse width (self refresh)	$t_{\text{RASS}}$	100	—	100	—	100	—	$\mu\text{s}$	24, 25, 26
$\overline{\text{RAS}}$ precharge time (self refresh)	$t_{\text{RPS}}$	110	—	130	—	150	—	ns	
$\overline{\text{CAS}}$ hold time (self refresh)	$t_{\text{CHS}}$	-50	—	-50	—	-50	—	ns	21



Notes: 1. AC measurements assume  $t_T = 5$  ns.

- Assumes that  $t_{\text{RCD}} \leq t_{\text{RCD}}(\text{max})$  and  $t_{\text{RAD}} \leq t_{\text{RAD}}(\text{max})$ . If  $t_{\text{RCD}}$  or  $t_{\text{RAD}}$  is greater than the maximum recommended value shown in this table,  $t_{\text{RAC}}$  exceeds the value shown.
- Measured with a load circuit equivalent to 2 TTL loads and 100 pF (HM51(S)4260C-6/7/8), 2 TTL 50 pF (HM51(S)4260C-6R).
- Assumes that  $t_{\text{RCD}} \geq t_{\text{RCD}}(\text{max})$  and  $t_{\text{RAD}} \leq t_{\text{RAD}}(\text{max})$ .
- Assumes that  $t_{\text{RCD}} \leq t_{\text{RCD}}(\text{max})$  and  $t_{\text{RAD}} \geq t_{\text{RAD}}(\text{max})$ .
- $t_{\text{OFF}}(\text{max})$  defines the time at which the output achieves the open circuit condition and is not referred to output voltage levels.
- $V_{\text{IH}}(\text{min})$  and  $V_{\text{IL}}(\text{max})$  are reference levels for measuring timing of input signals. Also, transition times are measured between  $V_{\text{IH}}$  and  $V_{\text{IL}}$ .
- Operation with the  $t_{\text{RCD}}(\text{max})$  limit insures that  $t_{\text{RAC}}(\text{max})$  can be met,  $t_{\text{RCD}}(\text{max})$  is specified as a reference point only, if  $t_{\text{RCD}}$  is greater than the specified  $t_{\text{RCD}}(\text{max})$  limit, then access time is controlled exclusively by  $t_{\text{CAC}}$ .
- Operation with the  $t_{\text{RAD}}(\text{max})$  limit insures that  $t_{\text{RAC}}(\text{max})$  can be met,  $t_{\text{RAD}}(\text{max})$  is specified as a reference point only, if  $t_{\text{RAD}}$  is greater than the specified  $t_{\text{RAD}}(\text{max})$  limit, then access time is controlled exclusively by  $t_{\text{AA}}$ .
- $t_{\text{WCS}}$ ,  $t_{\text{RWD}}$ ,  $t_{\text{CWD}}$  and  $t_{\text{AWD}}$  are not restrictive operating parameters. They are included in the data sheet as electrical characteristics only: if  $t_{\text{WCS}} \geq t_{\text{WCS}}(\text{min})$ , the cycle is an early write cycle and the data out pin will remain open circuit (high impedance) throughout the entire cycle; if  $t_{\text{RWD}} \geq t_{\text{RWD}}(\text{min})$ ,  $t_{\text{CWD}} \geq t_{\text{CWD}}(\text{min})$ ,  $t_{\text{AWD}} \geq t_{\text{AWD}}(\text{min})$  and  $t_{\text{CPW}} \geq t_{\text{CPW}}(\text{min})$ , the cycle is a read-modify-write and the data output will contain data read from the selected cell; if neither of the above sets of conditions is satisfied, the condition of the data out (at access time) is indeterminate.
- These parameters are referred to  $\overline{\text{CAS}}$  leading edge in an early write cycle and to  $\overline{\text{WE}}$  leading edge in a delayed write or a read-modify-write cycle.
- $t_{\text{RASC}}$  defines  $\overline{\text{RAS}}$  pulse width in fast page mode cycles.
- Access time is determined by the longest among  $t_{\text{AA}}$ ,  $t_{\text{CAC}}$  and  $t_{\text{ACP}}$ .
- An initial pause of 100  $\mu\text{s}$  is required after power up followed by a minimum of eight initialization cycles ( $\overline{\text{RAS}}$ -only refresh cycle or  $\overline{\text{CAS}}$ -before- $\overline{\text{RAS}}$  refresh cycle). If the internal refresh counter is used, a minimum of eight  $\overline{\text{CAS}}$ -before- $\overline{\text{RAS}}$  refresh cycles is required.
- In delayed write or read-modify-write cycles,  $\overline{\text{OE}}$  must disable output buffer prior to applying data to the device.
- Either  $t_{\text{RCH}}$  or  $t_{\text{RRH}}$  must be satisfied for a read cycle.
- When both  $\overline{\text{UCAS}}$  and  $\overline{\text{LCAS}}$  go low at the same time, all 16-bits data are written into the device.  $\overline{\text{UCAS}}$  and  $\overline{\text{LCAS}}$  cannot be staggered within the same write/read cycles.
- All the  $V_{\text{CC}}$  and  $V_{\text{SS}}$  pins shall be supplied with the same voltages.
- $t_{\text{ASC}}$ ,  $t_{\text{CAH}}$ ,  $t_{\text{RCS}}$ ,  $t_{\text{WCS}}$ ,  $t_{\text{WCH}}$ ,  $t_{\text{CSR}}$  and  $t_{\text{RPC}}$  are determined by the earlier falling edge of  $\overline{\text{UCAS}}$  or  $\overline{\text{LCAS}}$ .
- $t_{\text{CRP}}$ ,  $t_{\text{CHR}}$ ,  $t_{\text{ACP}}$ ,  $t_{\text{RCH}}$  and  $t_{\text{CPW}}$  are determined by the later rising edge of  $\overline{\text{UCAS}}$  or  $\overline{\text{LCAS}}$ .
- $t_{\text{CWL}}$ ,  $t_{\text{DH}}$ ,  $t_{\text{DS}}$  and  $t_{\text{CHS}}$  should be satisfied by both  $\overline{\text{UCAS}}$  and  $\overline{\text{LCAS}}$ .

---

## HM514260C, HM51S4260C Series

---

22.  $t_{CPN}$  and  $t_{CP}$  are determined by the time that both  $\overline{UCAS}$  and  $\overline{LCAS}$  are high.
23. When output buffers are enabled once, sustain the low impedance state until valid data is obtained.  
When output buffer is turned on and off within a very short time, generally it causes large  $V_{CC}/V_{SS}$  line noise, which causes to degrade  $V_{IH\ min}/V_{IL\ max}$  level.
24. If you use distributed CBR refresh mode with 15.6  $\mu s$  interval in normal read/write cycle, CBR refresh should be executed within 15.6  $\mu s$  immediately after exiting from and before entering into self refresh mode.
25. If you use  $\overline{RAS}$  only refresh or CBR burst refresh mode in normal read/write cycle, 512 cycles of distributed CBR refresh with 15.6  $\mu s$  interval should be executed within 8 ms immediately after exiting from and before entering into the self refresh mode.
26. Repetitive self refresh mode without refreshing all memory is not allowed. Once you exit from self refresh mode, all memory cells need to be refreshed before re-entering the self refresh mode again.
27.  H or L (H:  $V_{IH\ (min)} \leq V_{IN} \leq V_{IH\ (max)}$ , L:  $V_{IL\ (min)} \leq V_{IN} \leq V_{IL\ (max)}$ )  
 Invalid Dout

---

## HM514260C, HM51S4260C Series

---

### Notes concerning $\overline{2CAS}$ control

Please do not separate the  $\overline{UCAS}/\overline{LCAS}$  operation timing intentionally. However skew between  $\overline{UCAS}/\overline{LCAS}$  are allowed under the following conditions.

- (1) Each of the  $\overline{UCAS}/\overline{LCAS}$  should satisfy the timing specifications individually.
- (2) Different operation mode for upper/lower byte is not allowed; such as following.

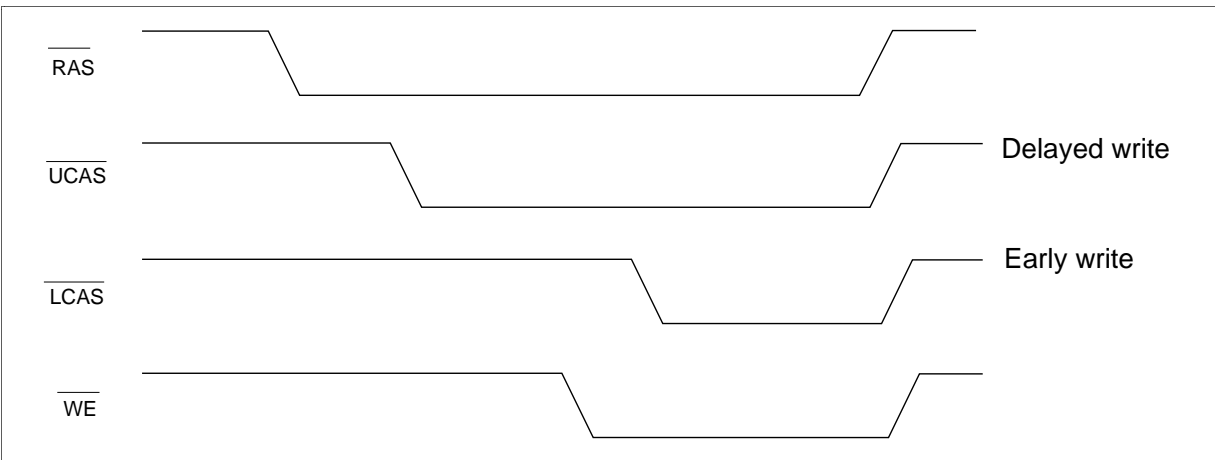

- (3) Closely separated upper/lower byte control is not allowed. However when the condition ( $t_{CP} \leq t_{UL}$ ) is satisfied, fast page mode can be performed.

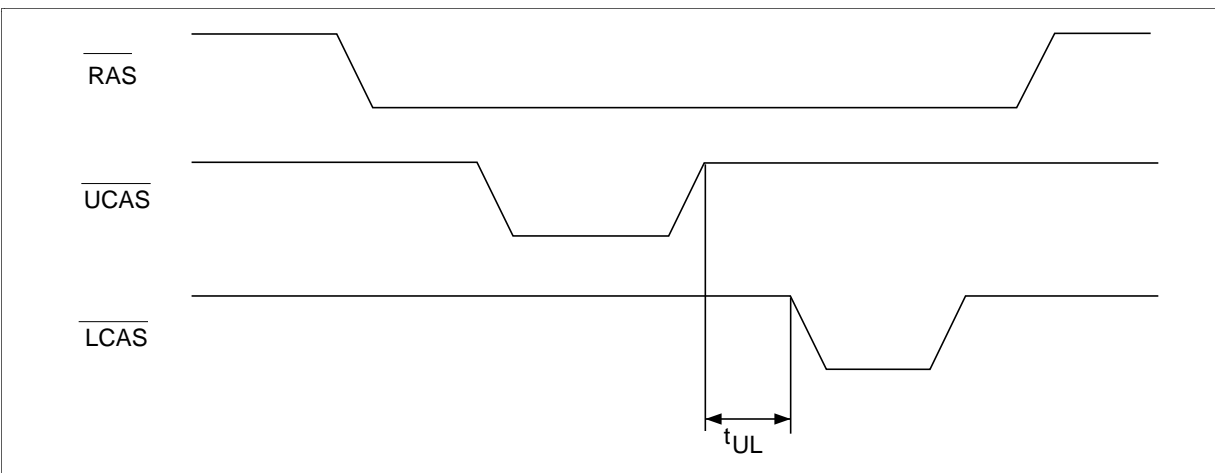

Timing Waveforms\*27

Read Cycle

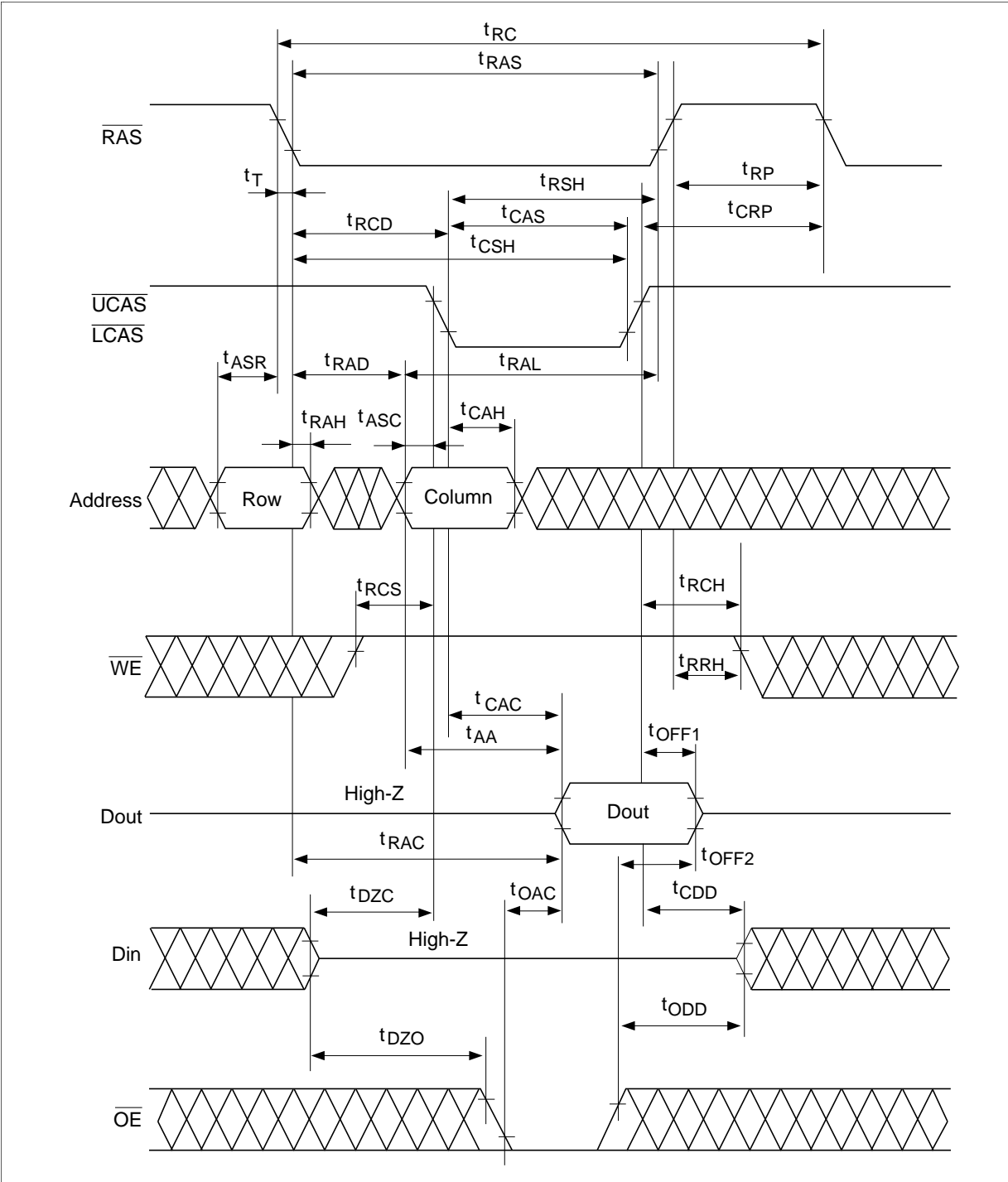

# HM514260C, HM51S4260C Series

## Early Write Cycle

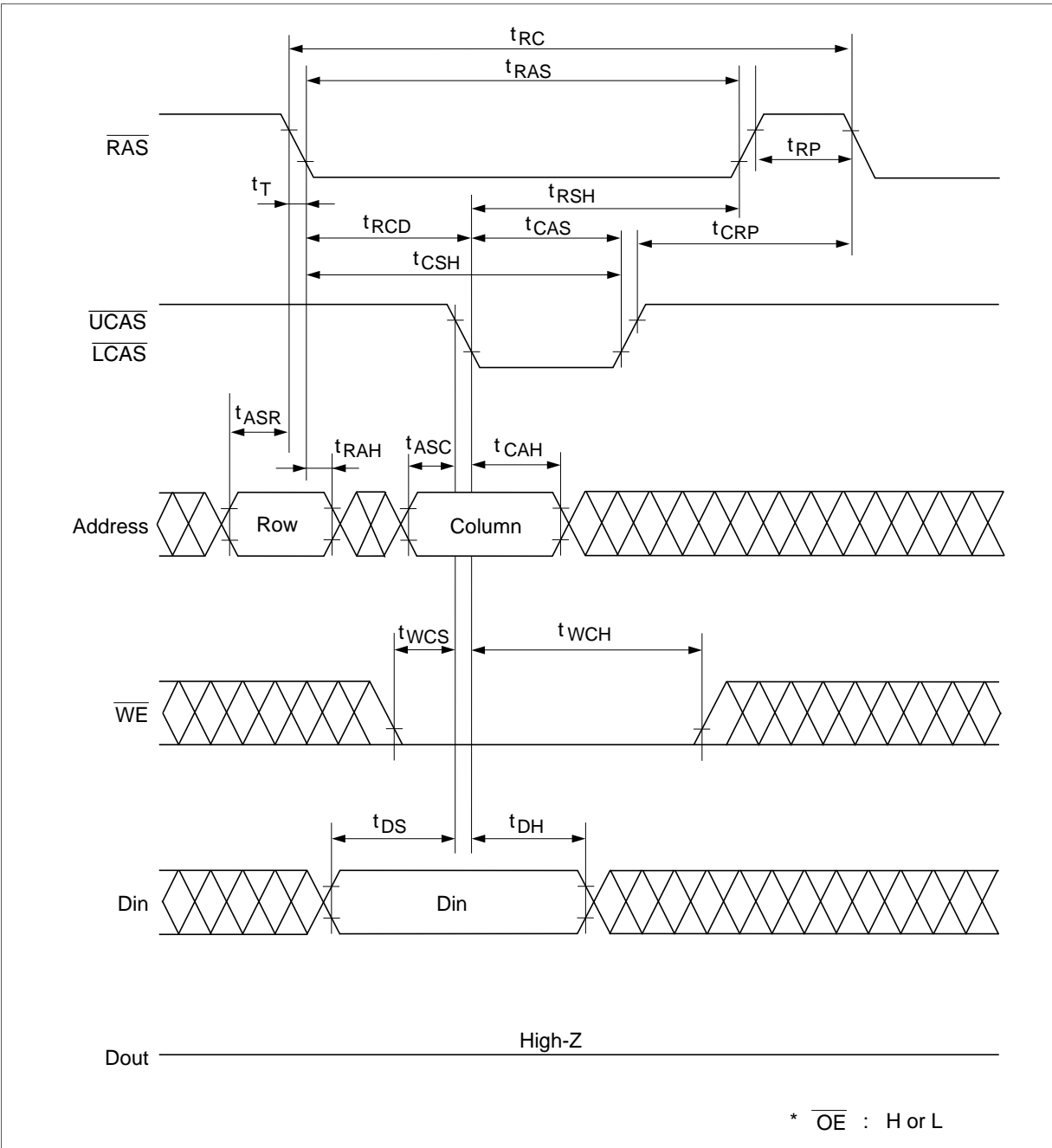



Delayed Write Cycle

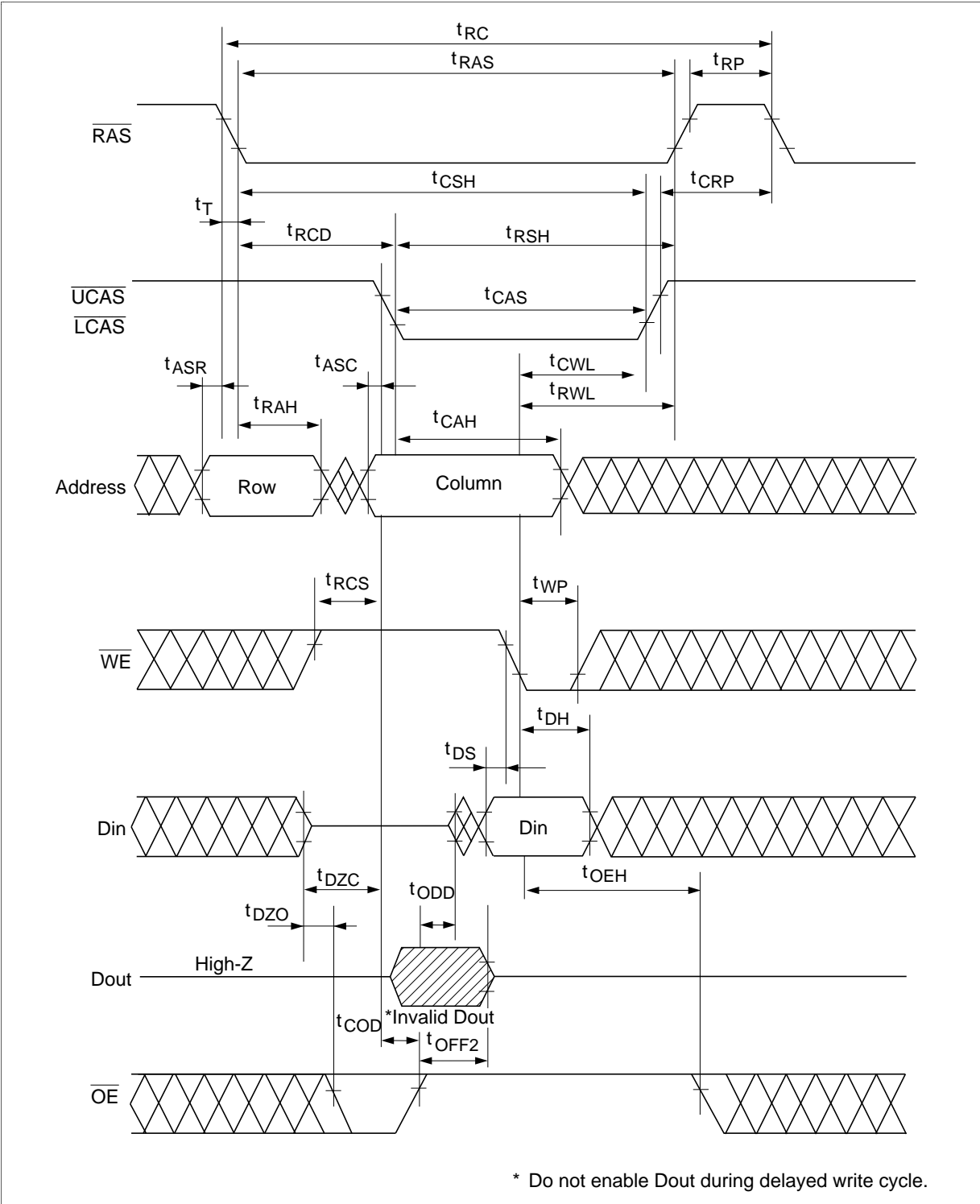

# HM514260C, HM51S4260C Series

## Read-Modify-Write Cycle

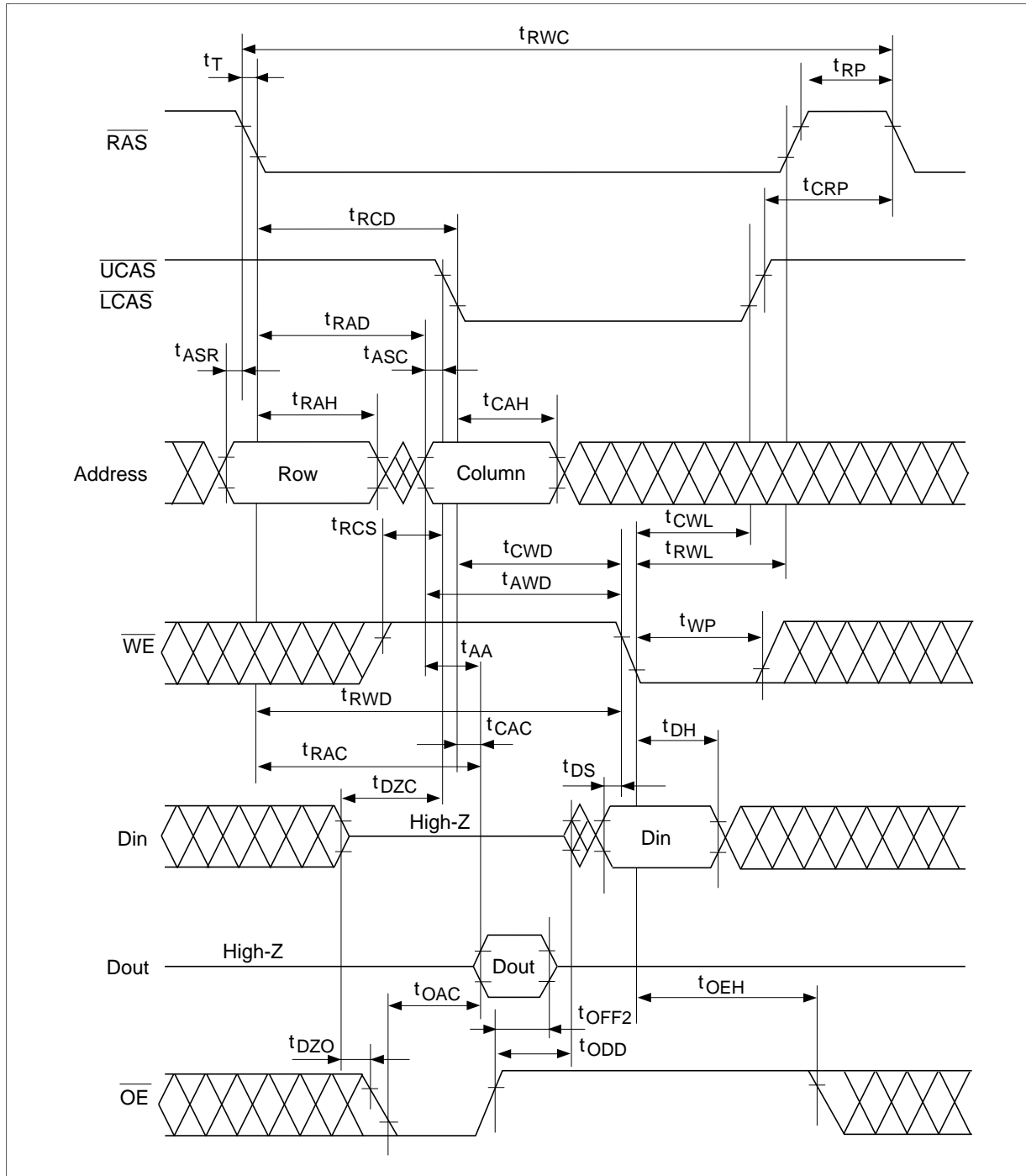

## HM514260C, HM51S4260C Series

### $\overline{\text{RAS}}$ -Only Refresh Cycle

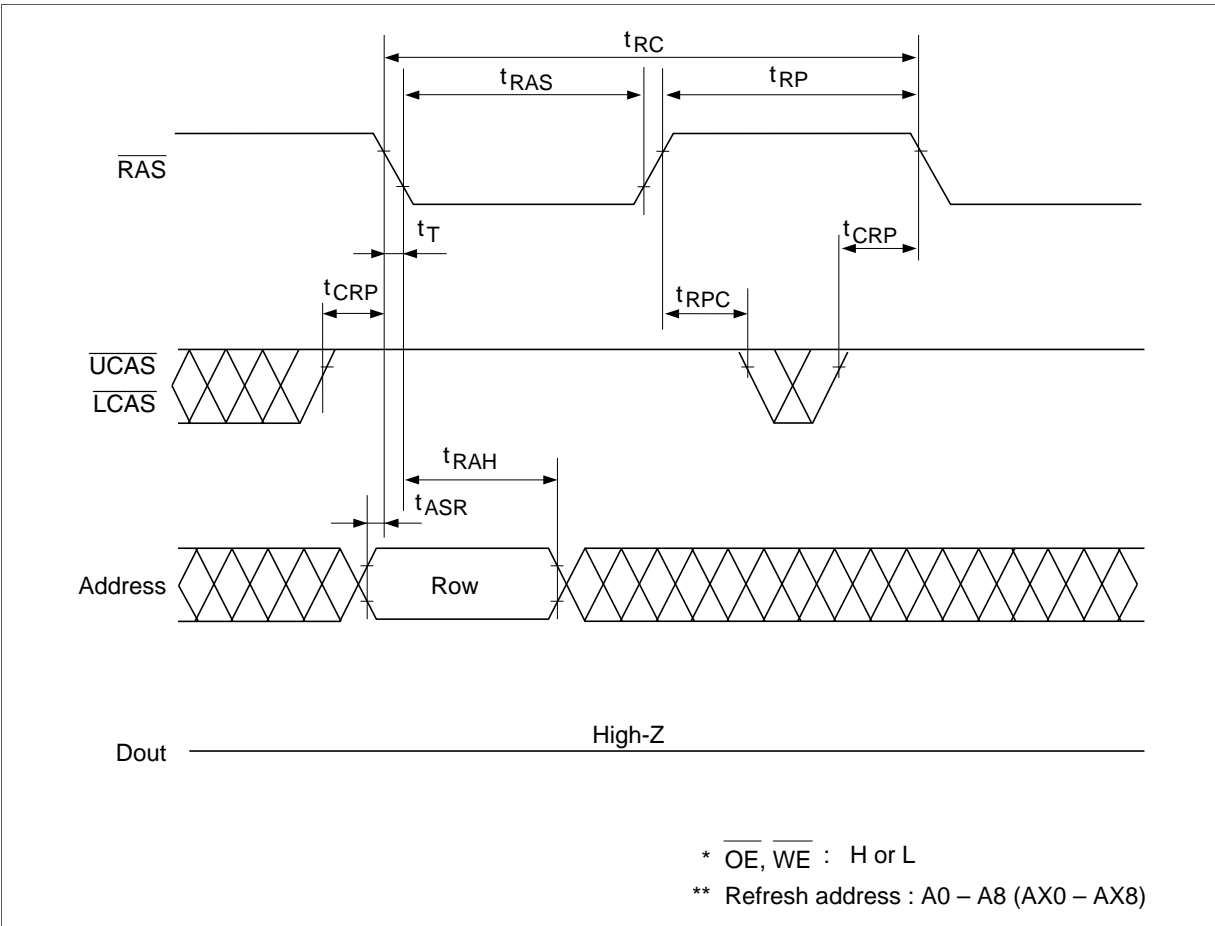

## HM514260C, HM51S4260C Series

### $\overline{\text{CAS}}$ -Before- $\overline{\text{RAS}}$ Refresh Cycle

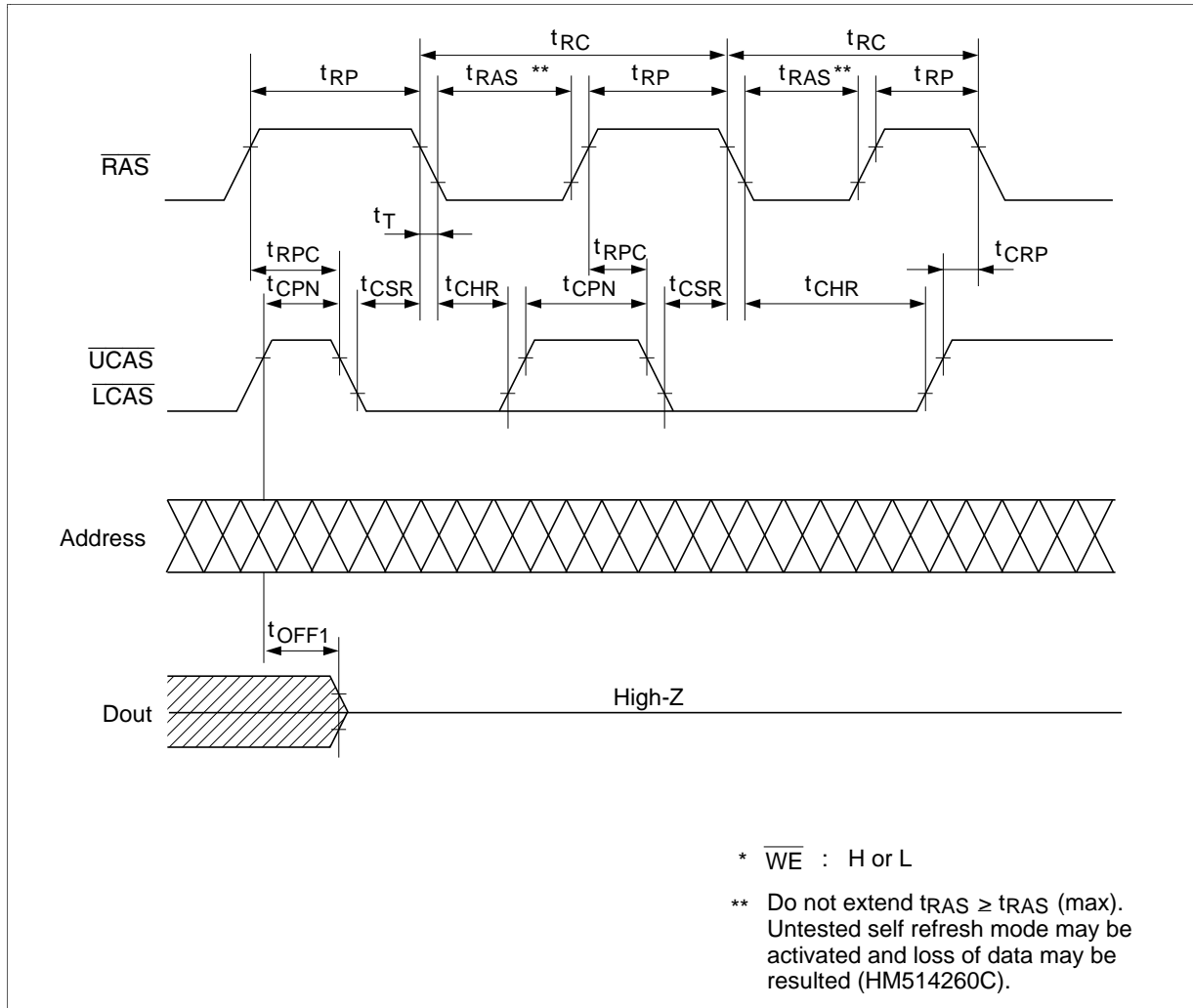

Fast Page Mode Read Cycle

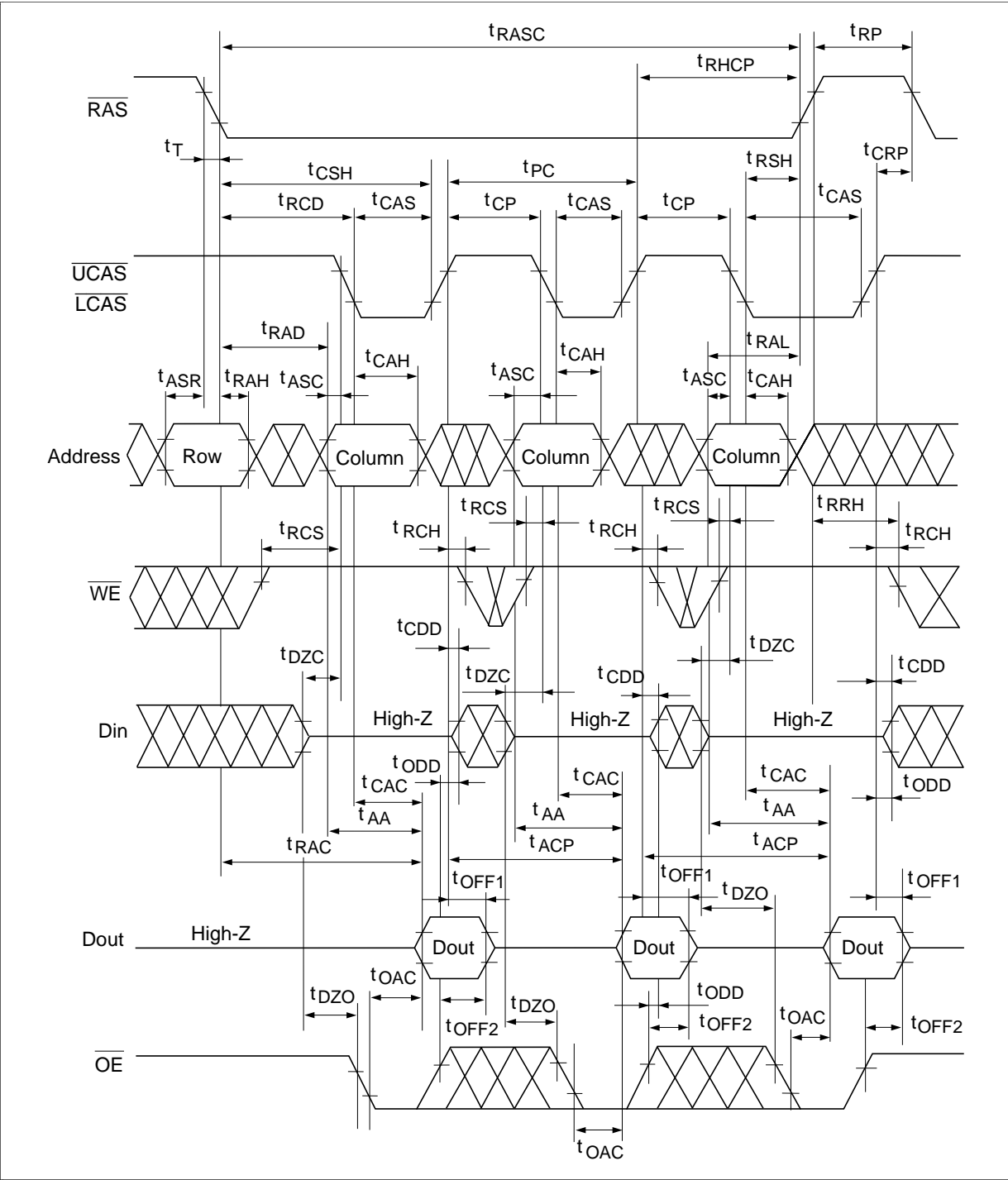

# HM514260C, HM51S4260C Series

## Fast Page Mode Early Write Cycle

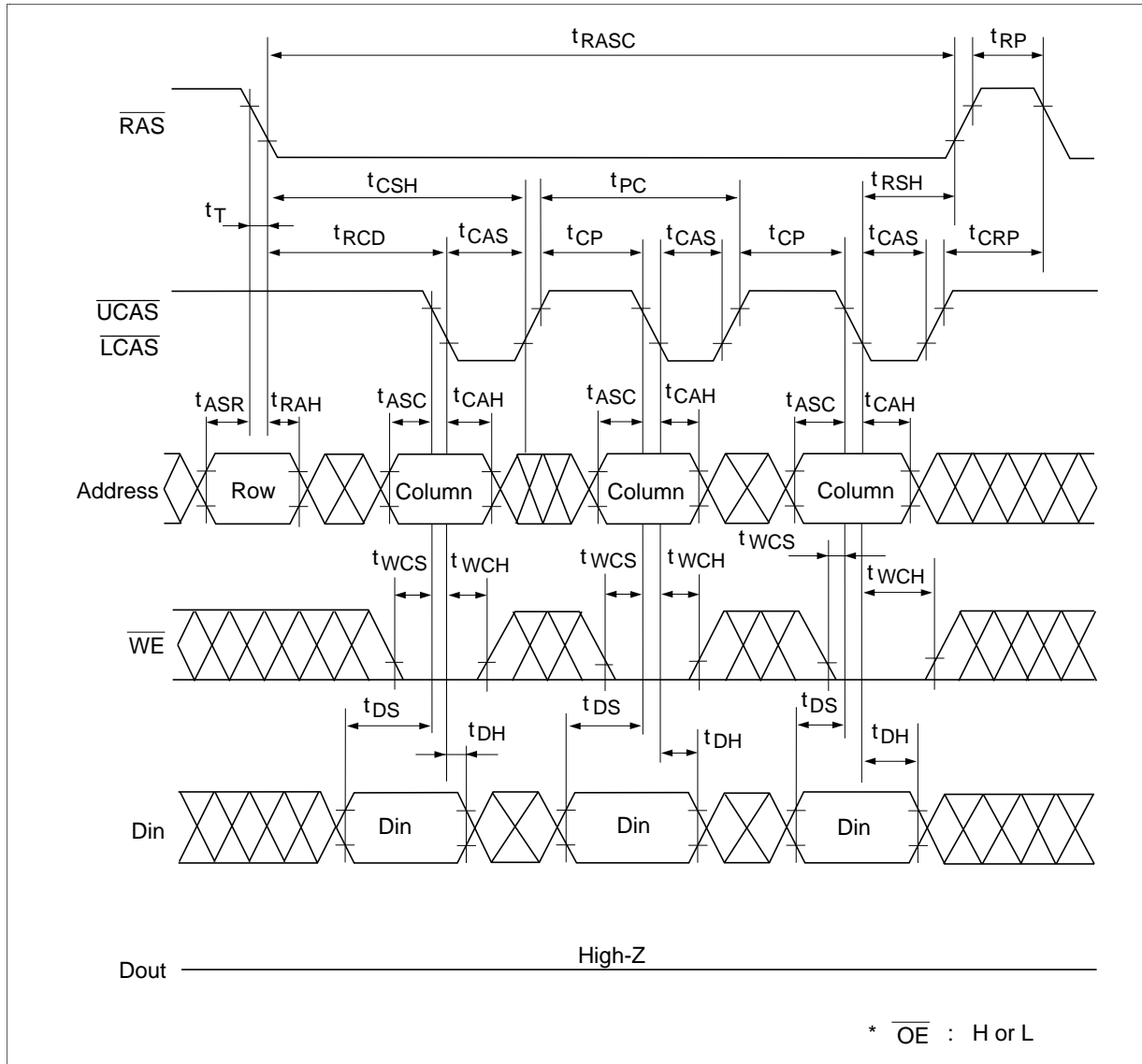

# HM514260C, HM51S4260C Series

## Fast Page Mode Delayed Write Cycle

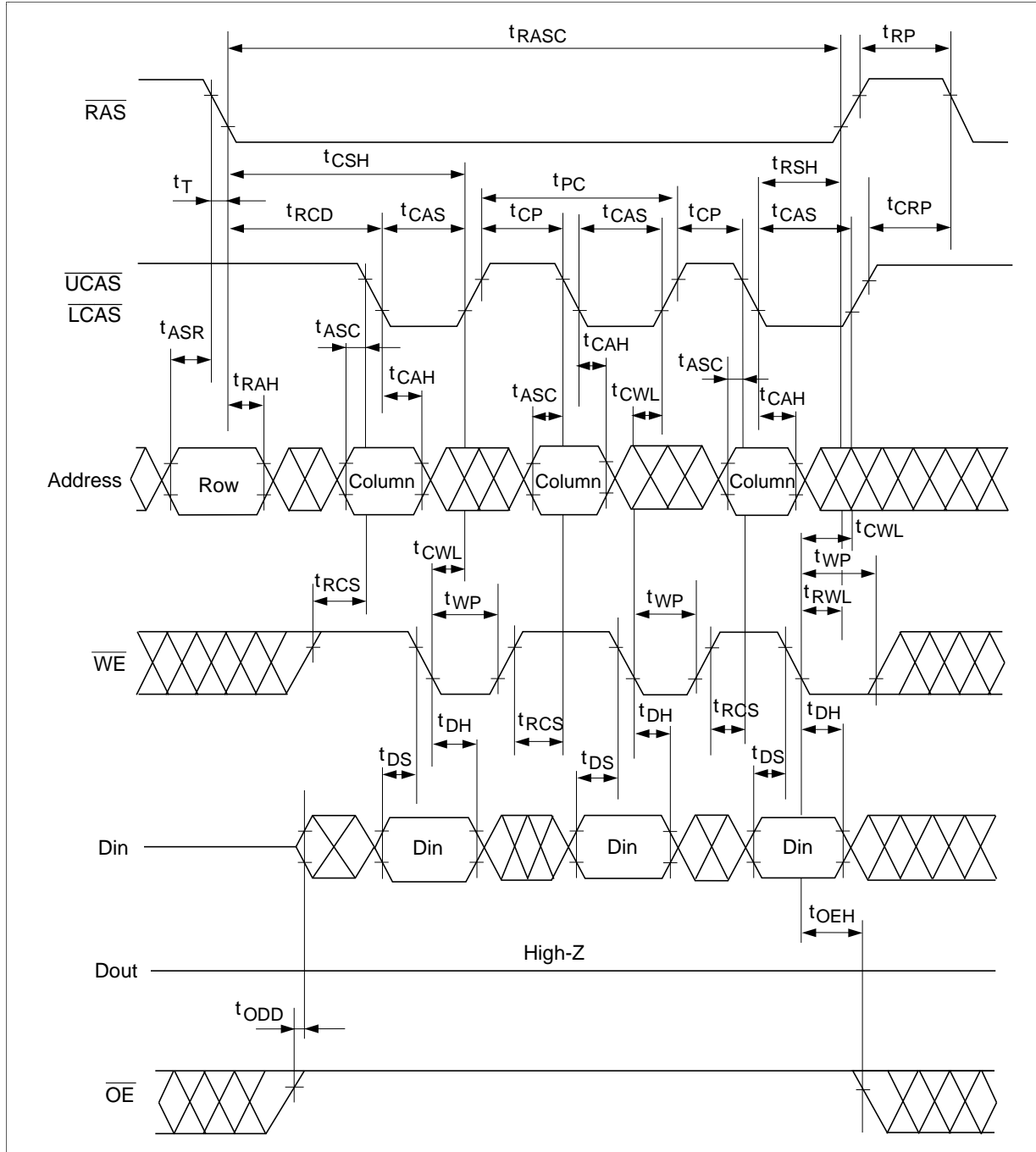

# HM514260C, HM51S4260C Series

## Fast Page Mode Read-Modify-Write Cycle

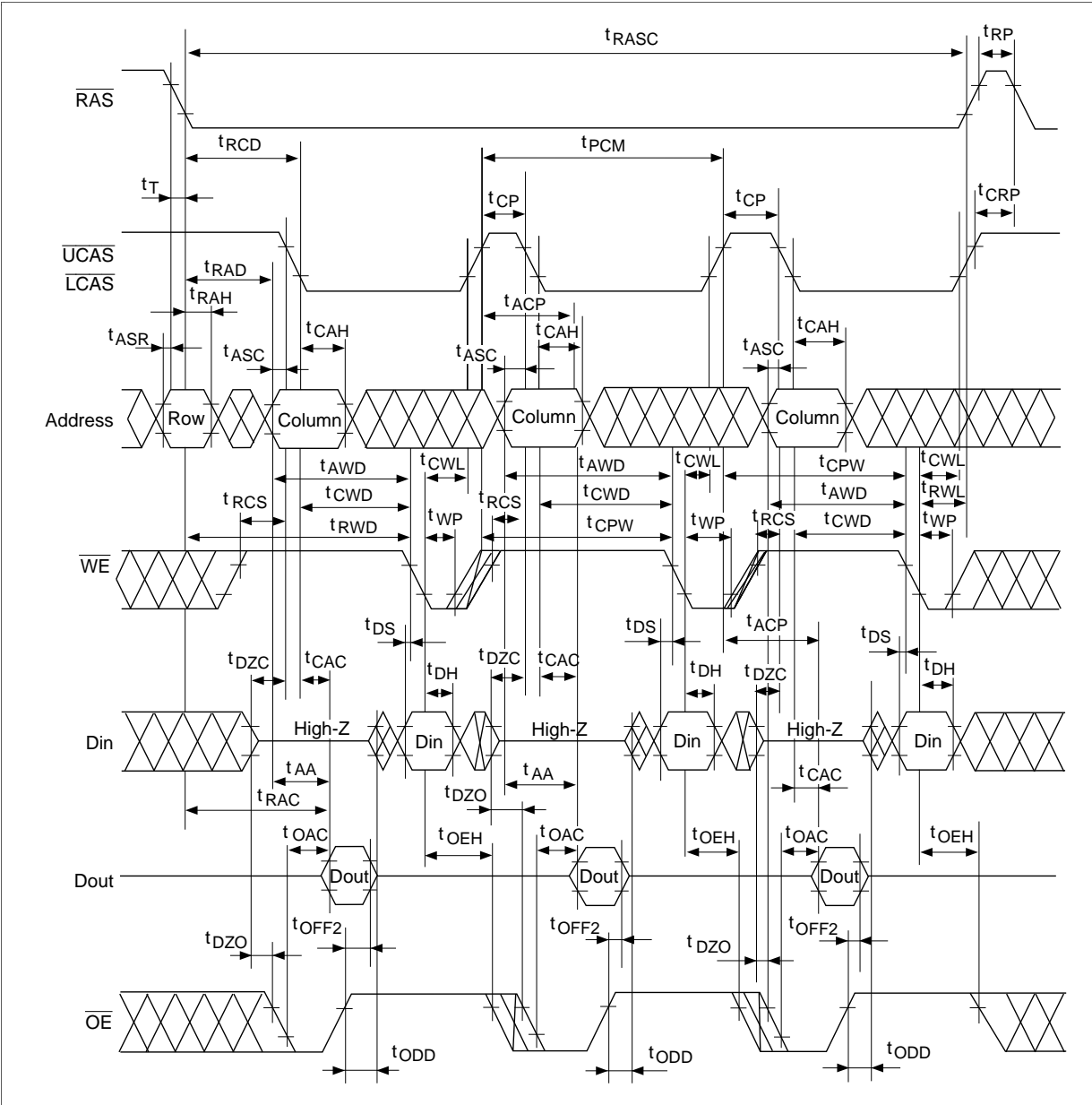



Self Refresh Cycle

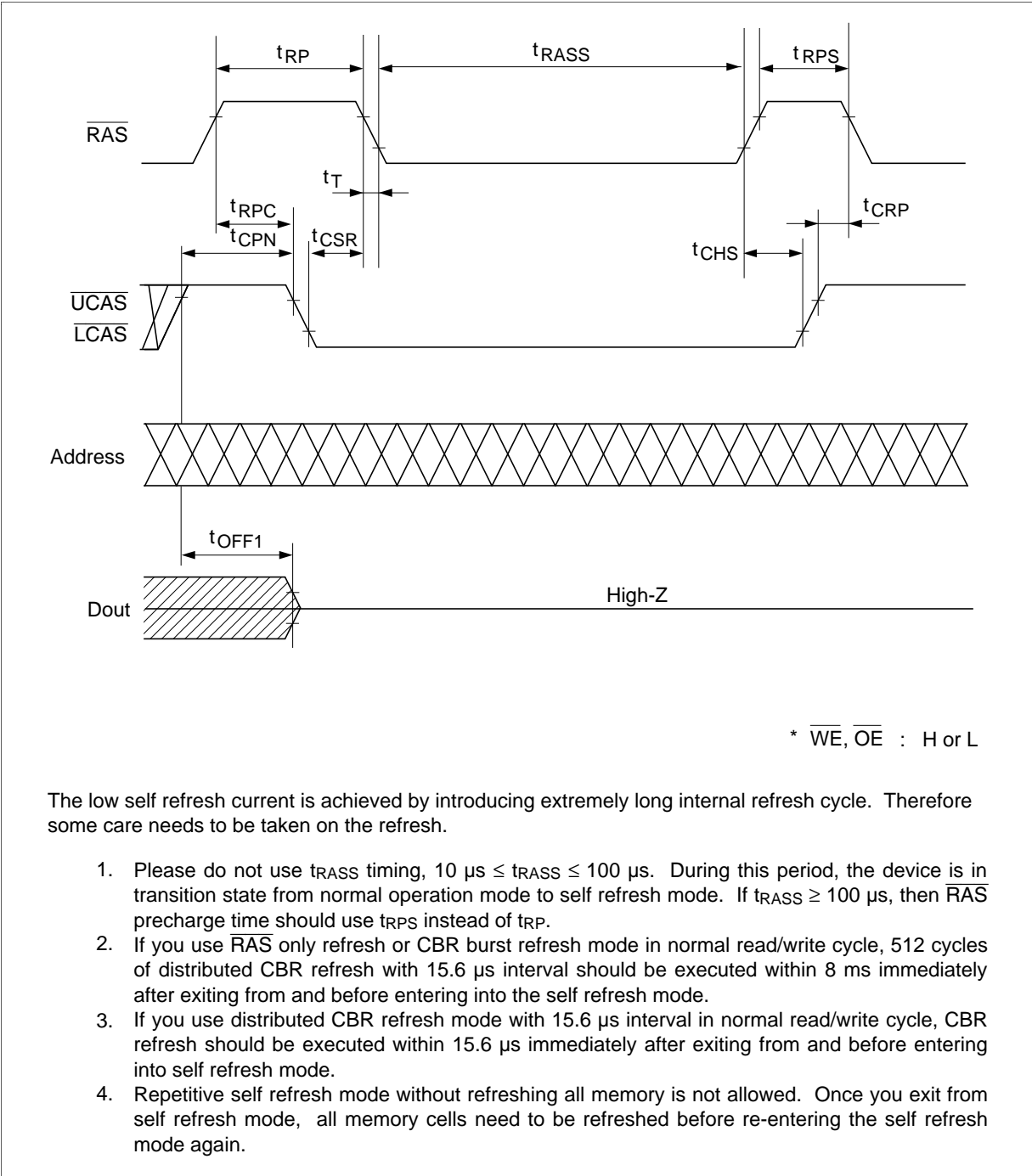

---

## HM514260C, HM51S4260C Series

---

### Package Dimensions

HM51(S)4260CJ/CLJ Series (CP-40DA)

Unit: mm

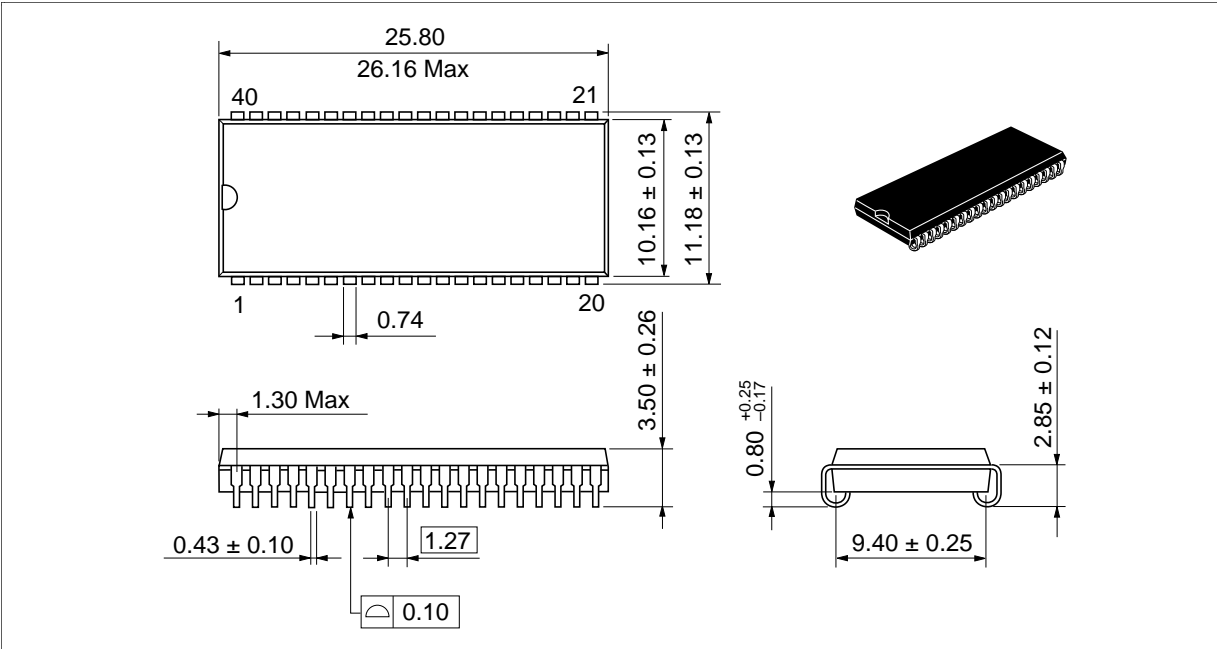

# HM514260C, HM51S4260C Series

HM51(S)4260CTT/CLTT Series (TTP44/40DB)

Unit: mm

