

4¹/₂ Digit, BCD Output, A/D Converter

The Intersil ICL7135 precision A/D converter, with its multiplexed BCD output and digit drivers, combines dual-slope conversion reliability with ± 1 in 20,000 count accuracy and is ideally suited for the visual display DVM/DPM market. The 2.0000V full scale capability, auto-zero, and auto-polarity are combined with true ratiometric operation, almost ideal differential linearity and true differential input. All necessary active devices are contained on a single CMOS IC, with the exception of display drivers, reference, and a clock.

The ICL7135 brings together an unprecedented combination of high accuracy, versatility, and true economy. It features auto-zero to less than 10 μ V, zero drift of less than 1 μ V/ $^{\circ}$ C, input bias current of 10pA (Max), and rollover error of less than one count. The versatility of multiplexed BCD outputs is increased by the addition of several pins which allow it to operate in more sophisticated systems. These include STROBE, OVERRANGE, UNDERRANGE, RUN/HOLD and BUSY lines, making it possible to interface the circuit to a microprocessor or UART.

Ordering Information

PART NUMBER	TEMP. RANGE ($^{\circ}$ C)	PACKAGE	PKG. DWG. #
ICL7135CPI	0 to 70	28 Ld PDIP	E28.6
ICL7135CPIZ (Note 1)	0 to 70	28 Ld PDIP (Pb-free) (Note 2)	E28.6

NOTES:

- Intersil Pb-free products employ special Pb-free material sets; molding compounds/die attach materials and 100% matte tin plate termination finish, which are RoHS compliant and compatible with both SnPb and Pb-free soldering operations. Intersil Pb-free products are MSL classified at Pb-free peak reflow temperatures that meet or exceed the Pb-free requirements of IPC/JEDEC J STD-020C.
- Pb-free PDIPs can be used for through hole wave solder processing only. They are not intended for use in Reflow solder processing applications.

Features

- Accuracy Guaranteed to ± 1 Count Over Entire ± 20000 Counts (2.0000V Full Scale)
- Guaranteed Zero Reading for 0V Input
- 1pA Typical Input Leakage Current
- True Differential Input
- True Polarity at Zero Count for Precise Null Detection
- Single Reference Voltage Required
- Overrange and Underrange Signals Available for Auto-Range Capability
- All Outputs TTL Compatible
- Blinking Outputs Gives Visual Indication of Overrange
- Six Auxiliary Inputs/Outputs are Available for Interfacing to UARTs, Microprocessors, or Other Circuitry
- Multiplexed BCD Outputs
- Pb-Free Available (RoHS Compliant)

Pinout

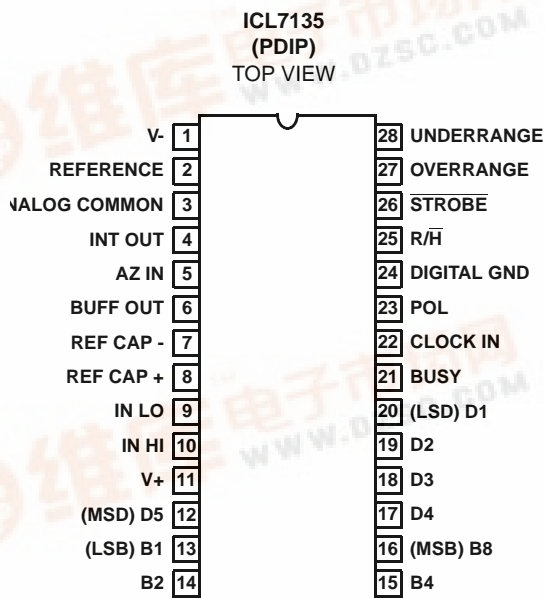

ICL7135

Typical Application Schematic

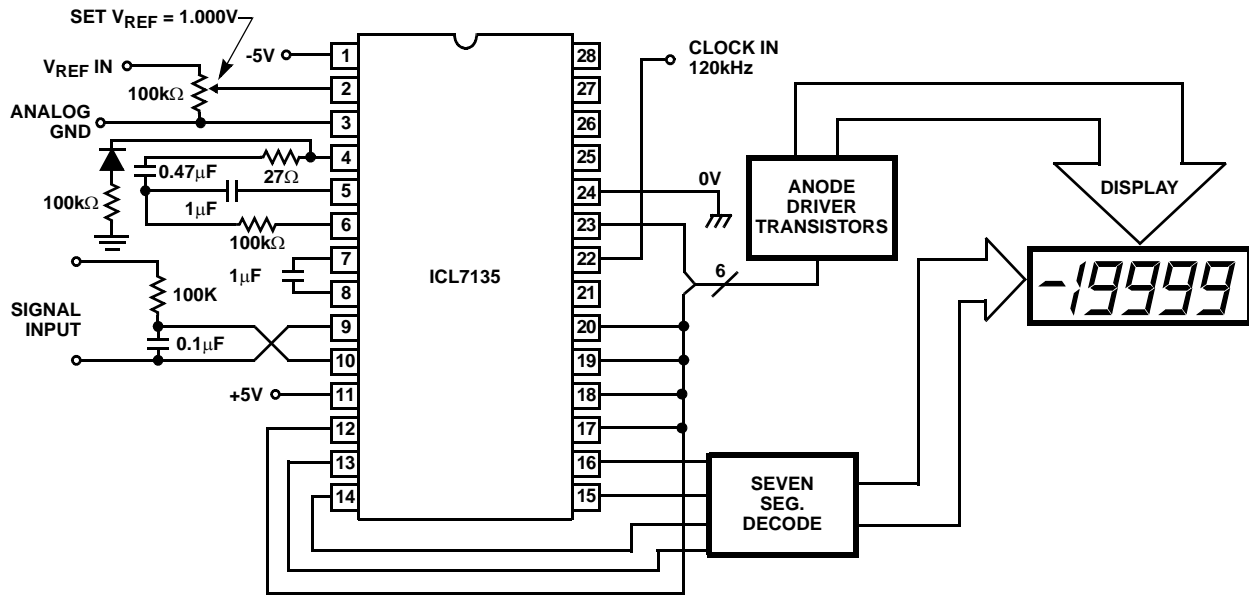

ICL7135

Absolute Maximum Ratings

Supply Voltage V+	+6V
V-	-9V
Analog Input Voltage (Either Input) (Note 1)	V+ to V-
Reference Input Voltage (Either Input)	V+ to V-
Clock Input Voltage	GND to V+

Operating Conditions

Temperature Range	0°C to 70°C
-------------------	-------------

Thermal Information

Thermal Resistance (Typical, Note 2)	θ_{JA} (°C/W)
PDIP Package	55
Maximum Junction Temperature	150°C
Maximum Storage Temperature Range	-65°C to 150°C
Maximum Lead Temperature (Soldering 10s)	300°C

NOTE: Pb-free PDIPs can be used for through hole wave solder processing only. They are not intended for use in Reflow solder processing applications.

CAUTION: Stresses above those listed in "Absolute Maximum Ratings" may cause permanent damage to the device. This is a stress only rating and operation of the device at these or any other conditions above those indicated in the operational sections of this specification is not implied.

NOTES:

- Input voltages may exceed the supply voltages provided the input current is limited to +100 μ A.
- θ_{JA} is measured with the component mounted on a low effective thermal conductivity test board in free air. See Tech Brief TB379 for details.

Electrical Specifications V+ = +5V, V- = -5V, T_A = 25°C, f_{CLK} Set for 3 Readings/s, Unless Otherwise Specified

PARAMETER	TEST CONDITIONS	MIN	TYP	MAX	UNITS	
ANALOG (Notes 3, 4)						
Zero Input Reading	V _{IN} = 0V, V _{REF} = 1.000V	-00000	+00000	+00000	Counts	
Ratiometric Error (Note 4)	V _{IN} = V _{REF} = 1.000V	-3	0	+3	Counts	
Linearity Over \pm Full Scale (Error of Reading from Best Straight Line)	-2V \leq V _{IN} \leq +2V	-	0.5	1	LSB	
Differential Linearity (Difference Between Worst Case Step of Adjacent Counts and Ideal Step)	-2V \leq V _{IN} \leq +2V	-	0.01	-	LSB	
Rollover Error (Difference in Reading for Equal Positive and Negative Voltage Near Full Scale)	-V _{IN} \equiv +V _{IN} \approx 2V	-	0.5	1	LSB	
Noise (Peak-to-Peak Value Not Exceeded 95% of Time), e _N	V _{IN} = 0V, Full scale = 2.000V	-	15	-	μ V	
Input Leakage Current, I _{ILK}	V _{IN} = 0V	-	1	10	pA	
Zero Reading Drift (Note 7)	V _{IN} = 0V, 0°C to 70°C	-	0.5	2	μ V/°C	
Scale Factor Temperature Coefficient, T _C (Notes 5 and 7)	V _{IN} = +2V, 0°C to 70°C Ext. Ref. 0ppm/°C	-	2	5	ppm/x°C	
DIGITAL INPUTS						
Clock In, Run/Hold (See Figure 2)	V _{INH}	2.8	2.2	-	V	
	V _{INL}	-	1.6	0.8	V	
	I _{INL}	V _{IN} = 0V	-	0.02	0.1	mA
	I _{INH}	V _{IN} = +5V	-	0.1	10	μ A
DIGITAL OUTPUTS						
All Outputs, V _{OL}	I _{OL} = 1.6mA	-	0.25	0.40	V	
B1, B2, B4, B8, D1, D2, D3, D4, D5, V _{OH}	I _{OH} = -1mA	2.4	4.2	-	V	
BUSY, $\overline{\text{STROBE}}$, $\overline{\text{OVERRANGE}}$, $\overline{\text{UNDERRANGE}}$, POLARITY, V _{OH}	I _{OH} = -10 μ A	4.9	4.99	-	V	
SUPPLY						
+5V Supply Range, V+		+4	+5	+6	V	
-5V Supply Range, V-		-3	-5	-8	V	
+5V Supply Current, I+	f _C = 0	-	1.1	3.0	mA	
-5V Supply Current, I-	f _C = 0	-	0.8	3.0	mA	
Power Dissipation Capacitance, C _{PD}	vs Clock Frequency	-	40	-	pF	
CLOCK						
Clock Frequency (Note 6)		DC	2000	1200	kHz	

NOTES:

- Tested in 4^{1/2} digit (20,000 count) circuit shown in Figure 3. (Clock frequency 120kHz.)
- Tested with a low dielectric absorption integrating capacitor, the 27 Ω INT OUT resistor shorted, and R_{INT} = 0. See Component Value Selection Discussion.
- The temperature range can be extended to 70°C and beyond as long as the auto-zero and reference capacitors are increased to absorb the higher leakage of the ICL7135.
- This specification relates to the clock frequency range over which the ICL7135 will correctly perform its various functions See "Max Clock Frequency" section for limitations on the clock frequency range in a system.
- Parameter guaranteed by design or characterization. Not production tested.

ICL7135

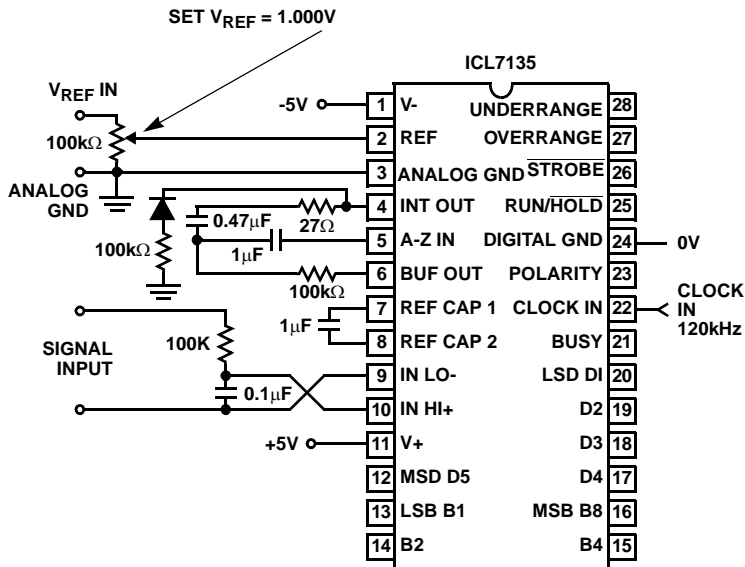

FIGURE 1. ICL7135 TEST CIRCUIT

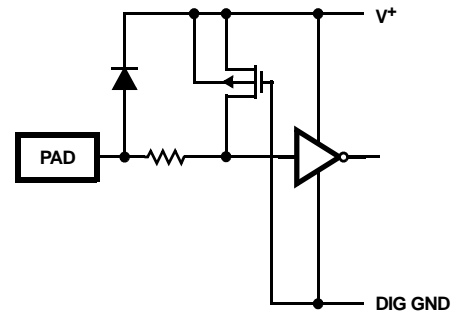

FIGURE 2. ICL7135 DIGITAL LOGIC INPUT

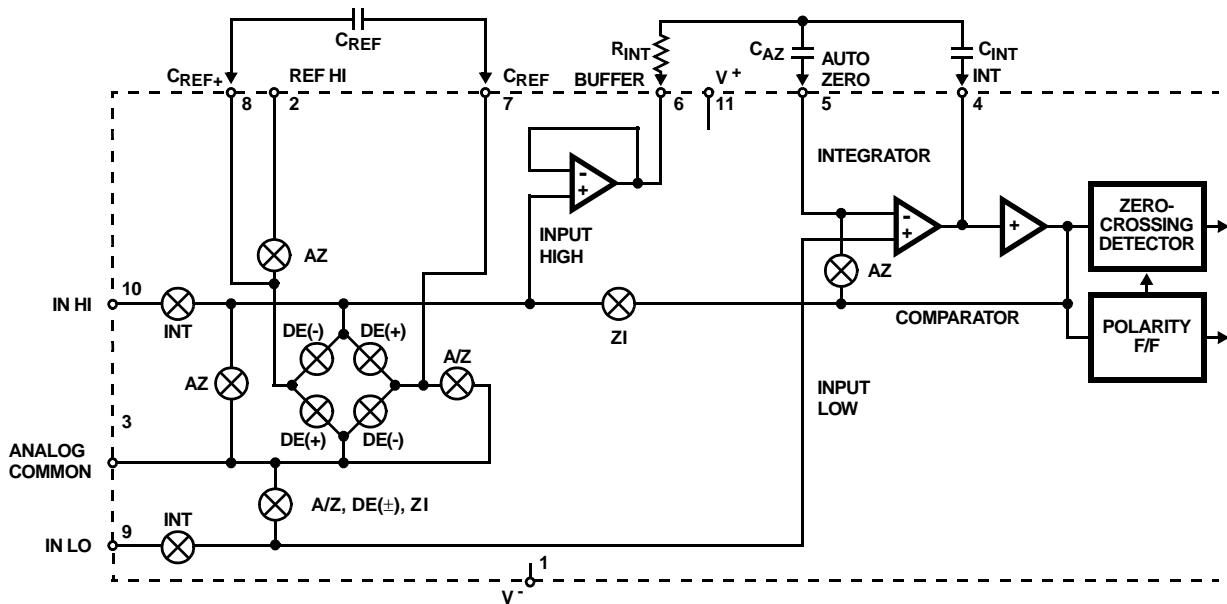

FIGURE 3. ANALOG SECTION OF ICL7135

Detailed Description

Analog Section

Figure 3 shows the Block Diagram of the Analog Section for the ICL7135. Each measurement cycle is divided into four phases. They are (1) auto-zero (AZ), (2) signal-integrate (INT), (3) de-integrate (DE) and (4) zero-integrator (ZI).

Auto-Zero Phase

During auto-zero, three things happen. First, input high and low are disconnected from the pins and internally shorted to analog COMMON. Second, the reference capacitor is charged to the reference voltage. Third, a feedback loop is closed around the system to charge the auto-zero capacitor C_{AZ} to compensate for offset voltages in the buffer amplifier, integrator, and comparator. Since the comparator is included in the loop, the AZ accuracy is limited only by the noise of the system. In any case, the offset referred to the input is less than $10\mu\text{V}$.

Signal Integrate Phase

During signal integrate, the auto-zero loop is opened, the internal short is removed, and the internal input high and low are connected to the external pins. The converter then integrates the differential voltage between IN HI and IN LO for a fixed time. This differential voltage can be within a wide common mode range; within one volt of either supply. If, on the other hand, the input signal has no return with respect to the converter power supply, IN LO can be tied to analog COMMON to establish the correct common-mode voltage. At the end of this phase, the polarity of the integrated signal is latched into the polarity F/F.

De-Integrate Phase

The third phase is de-integrate or reference integrate. Input low is internally connected to analog COMMON and input high is connected across the previously charged reference capacitor. Circuitry within the chip ensures that the capacitor will be connected with the correct polarity to cause the integrator output to return to zero. The time required for the output to return to zero is proportional to the input signal. Specifically the digital reading displayed is:

$$\text{OUTPUT COUNT} = 10,000 \left(\frac{V_{\text{IN}}}{V_{\text{REF}}} \right).$$

Zero Integrator Phase

The final phase is zero integrator. First, input low is shorted to analog COMMON. Second, a feedback loop is closed around the system to input high to cause the integrator output to return to zero. Under normal condition, this phase lasts from 100 to 200 clock pulses, but after an overrange conversion, it is extended to 6200 clock pulses.

Differential Input

The input can accept differential voltages anywhere within the common mode range of the input amplifier; or specifically from 0.5V below the positive supply to 1V above the negative supply. In this range the system has a CMRR of 86dB typical.

However, since the integrator also swings with the common mode voltage, care must be exercised to assure the integrator output does not saturate. A worst case condition would be a large positive common-mode voltage with a near full scale negative differential input voltage. The negative input signal drives the integrator positive when most of its swing has been used up by the positive common mode voltage. For these critical applications the integrator swing can be reduced to less than the recommended 4V full scale swing with some loss of accuracy. The integrator output can swing within 0.3V of either supply without loss of linearity.

Analog COMMON

Analog COMMON is used as the input low return during auto-zero and de-integrate. If IN LO is different from analog COMMON, a common mode voltage exists in the system and is taken care of by the excellent CMRR of the converter. However, in most applications IN LO will be set at a fixed known voltage (power supply common for instance). In this application, analog COMMON should be tied to the same point, thus removing the common mode voltage from the converter. The reference voltage is referenced to analog COMMON.

Reference

The reference input must be generated as a positive voltage with respect to COMMON, as shown in Figure 4.

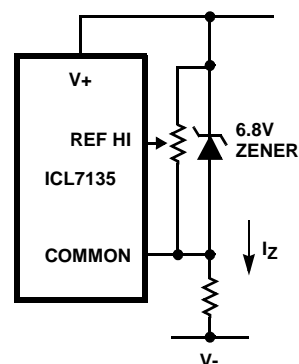

FIGURE 4A.

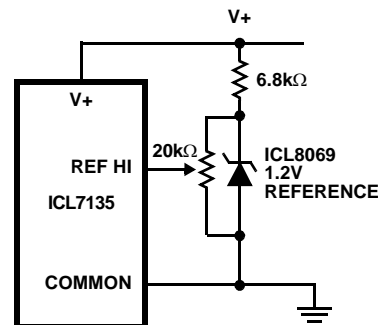

FIGURE 4B.

FIGURE 4. USING AN EXTERNAL REFERENCE

ICL7135

Digital Section

Figure 5 shows the Digital Section of the ICL7135. The ICL7135 includes several pins which allow it to operate conveniently in more sophisticated systems. These include:

Run/HOLD (Pin 25)

When high (or open) the A/D will free-run with equally spaced measurement cycles every 40,002 clock pulses. If taken low, the converter will continue the full measurement cycle that it is doing and then hold this reading as long as $\overline{R/\overline{H}}$ is held low. A short positive pulse (greater than 300ns) will now initiate a new measurement cycle, beginning with between 1 and 10,001 counts of auto zero. If the pulse occurs before the full measurement cycle (40,002 counts) is completed, it will not be recognized and the converter will simply complete the measurement it is doing. An external indication that a full measurement cycle has been completed is that the first strobe pulse (see below) will occur 101 counts after the end of this cycle. Thus, if $\overline{R/\overline{H}}$ is low and has been low for at least 101 counts, the converter is holding and ready to start a new measurement when pulsed high.

STROBE (Pin 26)

This is a negative going output pulse that aids in transferring the BCD data to external latches, UARTs, or microprocessors. There are 5 negative going \overline{STROBE} pulses that occur in the center of each of the digit drive pulses and occur once and only once for each measurement cycle starting 101 clock pulses after the end of the full measurement cycle. Digit 5 (MSD) goes high at the end of the measurement cycle and stays on for 201 counts. In the center of this digit pulse (to avoid race conditions between changing BCD and digit drives) the first \overline{STROBE} pulse goes negative for $1/2$ clock pulse width. Similarly, after digit 5, digit 4 goes high (for 200 clock pulses) and 100 pulses later the \overline{STROBE} goes negative for the second time. This continues through digit 1 (LSD) when the fifth and last \overline{STROBE} pulse is sent. The digit drive will continue to scan (unless the

previous signal was overrange) but no additional \overline{STROBE} pulses will be sent until a new measurement is available.

BUSY (Pin 21)

BUSY goes high at the beginning of signal integrate and stays high until the first clock pulse after zero crossing (or after end of measurement in the case of an overrange). The internal latches are enabled (i.e., loaded) during the first clock pulse after busy and are latched at the end of this clock pulse. The circuit automatically reverts to $\overline{auto-zero}$ when not BUSY, so it may also be considered a $(\overline{ZI} + \overline{AZ})$ signal. A very simple means for transmitting the data down a single wire pair from a remote location would be to AND BUSY with clock and subtract 10,001 counts from the number of pulses received - as mentioned previously there is one "NO-count" pulse in each reference integrate cycle.

OVERRANGE (Pin 27)

This pin goes positive when the input signal exceeds the range (20,000) of the converter. The output F/F is set at the end of BUSY and is reset to zero at the beginning of reference integrate in the next measurement cycle.

UNDERRANGE (Pin 28)

This pin goes positive when the reading is 9% of range or less. The output F/F is set at the end of BUSY (if the new reading is 1800 or less) and is reset at the beginning of signal integrate of the next reading.

POLARITY (Pin 23)

This pin is positive for a positive input signal. It is valid even for a zero reading. In other words, +0000 means the signal is positive but less than the least significant bit. The converter can be used as a null detector by forcing equal frequency of (+) and (-) readings. The null at this point should be less than 0.1 LSB. This output becomes valid at the beginning of reference integrate and remains correct until it is revalidated for the next measurement.

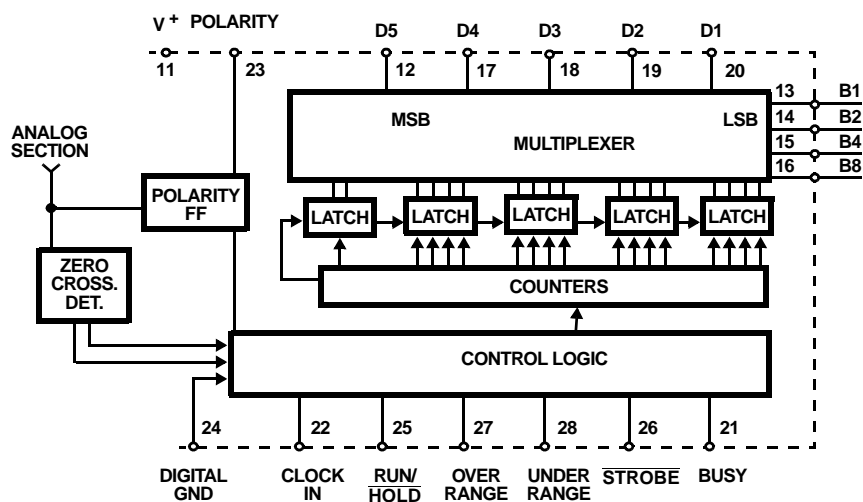

FIGURE 5. DIGITAL SECTION OF THE ICL7135

Digit Drives (Pins 12, 17, 18, 19 and 20)

Each digit drive is a positive going signal that lasts for 200 clock pulses. The scan sequence is D5 (MSD), D4, D3, D2, and D1 (LSD). All five digits are scanned and this scan is continuous unless an overrange occurs. Then all digit drives are blanked from the end of the strobe sequence until the beginning of Reference Integrate when D5 will start the scan again. This can give a blinking display as a visual indication of overrange.

BCD (Pins 13, 14, 15 and 16)

The Binary coded Decimal bits B8, B4, B2, and B1 are positive logic signals that go on simultaneously with the digit driver signal.

Component Value Selection

For optimum performance of the analog section, care must be taken in the selection of values for the integrator capacitor and resistor, auto-zero capacitor, reference voltage, and conversion rate. These values must be chosen to suit the particular application.

Integrating Resistor

The integrating resistor is determined by the full scale input voltage and the output current of the buffer used to charge the integrator capacitor. Both the buffer amplifier and the integrator have a class A output stage with 100µA of quiescent current. They can supply 20µA of drive current with negligible non-linearity. Values of 5µA to 40µA give good results, with a nominal of 20µA, and the exact value of integrating resistor may be chosen by:

$$R_{INT} = \frac{\text{full scale voltage}}{20\mu\text{A}}$$

Integrating Capacitor

The product of integrating resistor and capacitor should be selected to give the maximum voltage swing which ensures that the tolerance built-up will not saturate the integrator swing (approx. 0.3V from either supply). For ±5V supplies and analog COMMON tied to supply ground, a ±3.5V to ±4V full scale integrator swing is fine, and 0.47µF is nominal. In general, the value of C_{INT} is given by:

$$C_{INT} = \left(\frac{[10,000 \times \text{clock period}] \times I_{INT}}{\text{integrator output voltage swing}} \right)$$

$$= \frac{(10,000) (\text{clock period}) (20\mu\text{A})}{\text{integrator output voltage swing}}$$

A very important characteristic of the integrating capacitor is that it has low dielectric absorption to prevent roll-over or ratiometric errors. A good test for dielectric absorption is to use the capacitor with the input tied to the reference.

This ratiometric condition should read half scale 0.9999, and any deviation is probably due to dielectric absorption. Polypropylene capacitors give undetectable errors at reasonable cost. Polystyrene and polycarbonate capacitors may also be used in less critical applications.

Auto-Zero and Reference Capacitor

The physical size of the auto-zero capacitor has an influence on the noise of the system. A larger capacitor value reduces system noise. A larger physical size increases system noise. The reference capacitor should be large enough such that stray capacitance to ground from its nodes is negligible.

The dielectric absorption of the reference cap and auto-zero cap are only important at power-on or when the circuit is recovering from an overload. Thus, smaller or cheaper caps can be used here if accurate readings are not required for the first few seconds of recovery.

Reference Voltage

The analog input required to generate a full scale output is V_{IN} = 2V_{REF}.

The stability of the reference voltage is a major factor in the overall absolute accuracy of the converter. For this reason, it is recommended that a high quality reference be used where high-accuracy absolute measurements are being made.

Rollover Resistor and Diode

A small rollover error occurs in the ICL7135, but this can be easily corrected by adding a diode and resistor in series between the INTEGRATOR OUTPUT and analog COMMON or ground. The value shown in the schematics is optimum for the recommended conditions, but if integrator swing or clock frequency is modified, adjustment may be needed. The diode can be any silicon diode such as 1N914. These components can be eliminated if rollover error is not important and may be altered in value to correct other (small) sources of rollover as needed.

Max Clock Frequency

The maximum conversion rate of most dual-slope A/D converters is limited by the frequency response of the comparator. The comparator in this circuit follows the integrator ramp with a 3µs delay, and at a clock frequency of 160kHz (6µs period) half of the first reference integrate clock period is lost in delay. This means that the meter reading will change from 0 to 1 with a 50µV input, 1 to 2 with a 150µV input, 2 to 3 with a 250µV input, etc. This transition at mid-point is considered desirable by most users; however, if the clock frequency is increased appreciably above 160kHz, the instrument will flash "1" on noise peaks even when the input is shorted.

For many dedicated applications where the input signal is always of one polarity, the delay of the comparator need not be a limitation. Since the non-linearity and noise do not increase substantially with frequency, clock rates of up to ~1MHz may be used. For a fixed clock frequency, the extra count or counts caused by comparator delay will be constant and can be subtracted out digitally.

The clock frequency may be extended above 160kHz without this error, however, by using a low value resistor in series

ICL7135

with the integrating capacitor. The effect of the resistor is to introduce a small pedestal voltage on to the integrator output at the beginning of the reference integrate phase. By careful selection of the ratio between this resistor and the integrating resistor (a few tens of ohms in the recommended circuit), the comparator delay can be compensated and the maximum clock frequency extended by approximately a factor of 3. At higher frequencies, ringing and second order breaks will cause significant non-linearities in the first few counts of the instrument. See Application Note AN017.

The minimum clock frequency is established by leakage on the auto-zero and reference caps. With most devices, measurement cycles as long as 10s give no measurable leakage error.

To achieve maximum rejection of 60Hz pickup, the signal integrate cycle should be a multiple of 60Hz. Oscillator frequencies of 300kHz, 200kHz, 150kHz, 120kHz, 100kHz, 40kHz, $33\frac{1}{3}$ kHz, etc. should be selected. For 50Hz rejection, oscillator frequencies of 250kHz, $166\frac{2}{3}$ kHz, 125kHz, 100kHz, etc. would be suitable. Note that 100kHz (2.5 readings/sec) will reject both 50Hz and 60Hz.

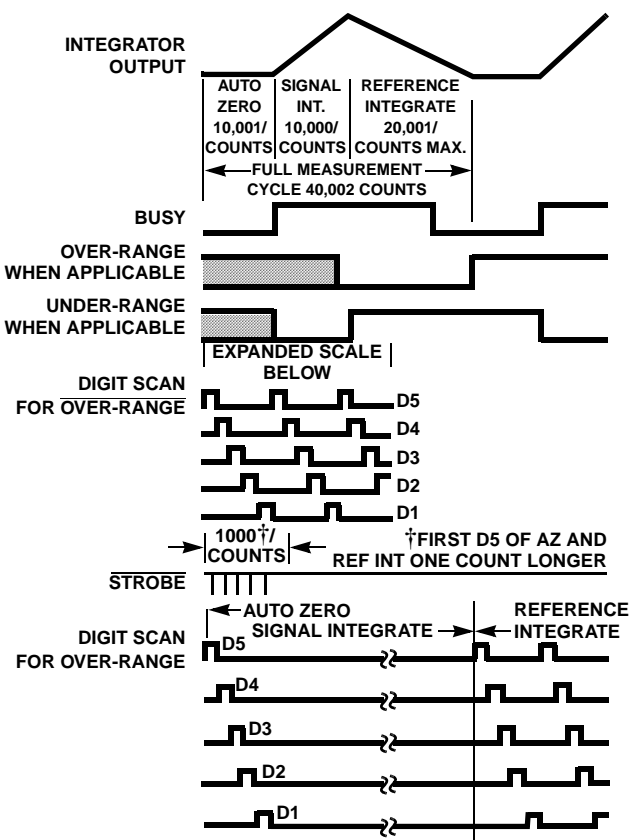

FIGURE 6. TIMING DIAGRAM FOR OUTPUTS

The clock used should be free from significant phase or frequency jitter. Several suitable low-cost oscillators are

shown in the Typical Applications section. The multiplexed output means that if the display takes significant current from the logic supply, the clock should have good PSRR.

Zero-Crossing Flip-Flop

The flip-flop interrogates the data once every clock pulse after the transients of the previous clock pulse and half-clock pulse have died down. False zero-crossings caused by clock pulses are not recognized. Of course, the flip-flop delays the true zero-crossing by up to one count in every instance, and if a correction were not made, the display would always be one count too high. Therefore, the counter is disabled for one clock pulse at the beginning of phase 3. This one-count delay compensates for the delay of the zero-crossing flip-flop, and allows the correct number to be latched into the display. Similarly, a one-count delay at the beginning of phase 1 gives an overload display of 0000 instead of 0001. No delay occurs during phase 2, so that true ratiometric readings result.

Evaluating The Error Sources

Errors from the "ideal" cycle are caused by:

1. Capacitor droop due to leakage.
2. Capacitor voltage change due to charge "suck-out" (the reverse of charge injection) when the switches turn off.
3. Non-linearity of buffer and integrator.
4. High-frequency limitations of buffer, integrator, and comparator.
5. Integrating capacitor non-linearity (dielectric absorption).
6. Charge lost by C_{REF} in charging C_{STRAY} .
7. Charge lost by C_{AZ} and C_{INT} to charge C_{STRAY} .

Each error is analyzed for its error contribution to the converter in application notes listed on the back page, specifically Application Note AN017 and Application Note AN032.

Noise

The peak-to-peak noise around zero is approximately $15\mu\text{V}$ (peak-to-peak value not exceeded 95% of the time). Near full scale, this value increases to approximately $30\mu\text{V}$. Much of the noise originates in the auto-zero loop, and is proportional to the ratio of the input signal to the reference.

Analog And Digital Grounds

Extreme care must be taken to avoid ground loops in the layout of ICL7135 circuits, especially in high-sensitivity circuits. It is most important that return currents from digital loads are not fed into the analog ground line.

ICL7135

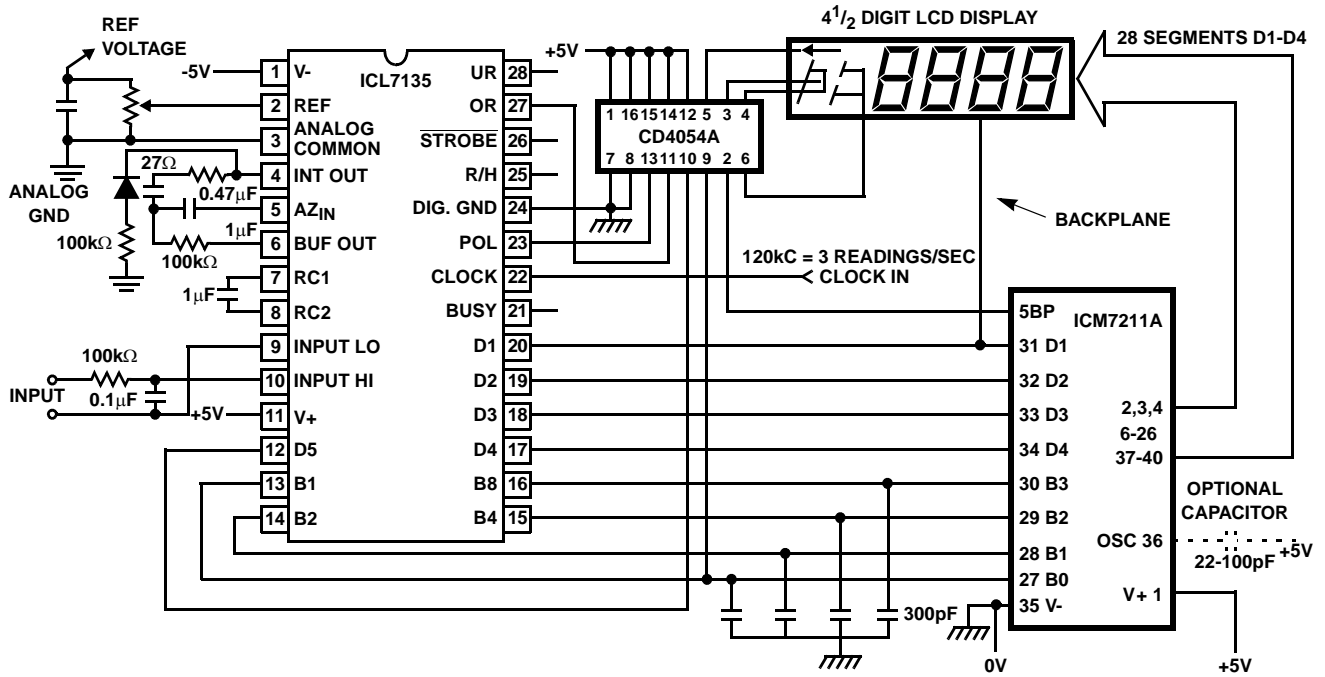

FIGURE 10. DRIVING LCD DISPLAYS

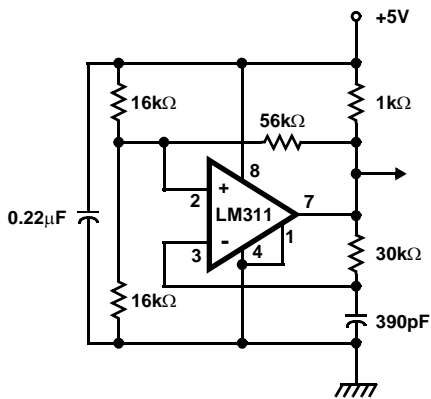

FIGURE 11. LM311 CLOCK SOURCE

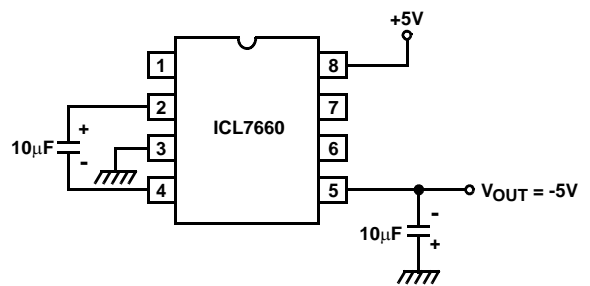

FIGURE 12. GENERATING A NEGATIVE SUPPLY FROM +5V

Design Information Summary Sheet

• **CLOCK INPUT**

The ICL7135 does not have an internal oscillator. It requires an external clock.

$$f_{\text{CLOCK}} (\text{Typ}) = 120\text{kHz}$$

• **CLOCK PERIOD**

$$t_{\text{CLOCK}} = 1/f_{\text{CLOCK}}$$

• **INTEGRATION PERIOD**

$$t_{\text{INT}} = 10,000 \times t_{\text{CLOCK}}$$

• **60/50Hz REJECTION CRITERION**

$$t_{\text{INT}}/t_{60\text{Hz}} \text{ or } t_{\text{INT}}/t_{50\text{Hz}} = \text{Integer}$$

• **OPTIMUM INTEGRATION CURRENT**

$$I_{\text{INT}} = 20\mu\text{A}$$

• **FULL-SCALE ANALOG INPUT VOLTAGE**

$$V_{\text{INFS}} (\text{Typ}) = 200\text{mV or } 2\text{V}$$

• **INTEGRATE RESISTOR**

$$R_{\text{INT}} = \frac{V_{\text{INFS}}}{I_{\text{INT}}}$$

• **INTEGRATE CAPACITOR**

$$C_{\text{INT}} = \frac{(t_{\text{INT}})(I_{\text{INT}})}{V_{\text{INT}}}$$

• **INTEGRATOR OUTPUT VOLTAGE SWING**

$$V_{\text{INT}} = \frac{(t_{\text{INT}})(I_{\text{INT}})}{C_{\text{INT}}}$$

• **V_{INT} MAXIMUM SWING:**

$$(V^- + 0.5) < V_{\text{INT}} < (V^+ - 0.5\text{V})$$

V_{INT} Typically = 2.7V

• **DISPLAY COUNT**

$$\text{COUNT} = 10,000 \times \frac{V_{\text{IN}}}{V_{\text{REF}}}$$

• **CONVERSION CYCLE**

$$t_{\text{CYC}} = t_{\text{CLOCK}} \times 40002$$

when $f_{\text{CLOCK}} = 120\text{kHz}$, $t_{\text{CYC}} = 333\text{ms}$

• **COMMON MODE INPUT VOLTAGE**

$$(V^- + 1\text{V}) < V_{\text{IN}} < (V^+ - 0.5\text{V})$$

• **AUTO-ZERO CAPACITOR**

$$0.01\mu\text{F} < C_{\text{AZ}} < 1\mu\text{F}$$

• **REFERENCE CAPACITOR**

$$0.1\mu\text{F} < C_{\text{REF}} < 1\mu\text{F}$$

• **POWER SUPPLY: DUAL ±5V**

V+ = +5V to GND

V- = -5V to GND

• **OUTPUT TYPE**

4 BCD Nibbles with Polarity and Overrange Bits

There is no internal reference available on the ICL7135. An external reference is required due to the ICL7135's $4^{1/2}$ digit resolution.

Typical Integrator Amplifier Output Waveform (INT Pin)

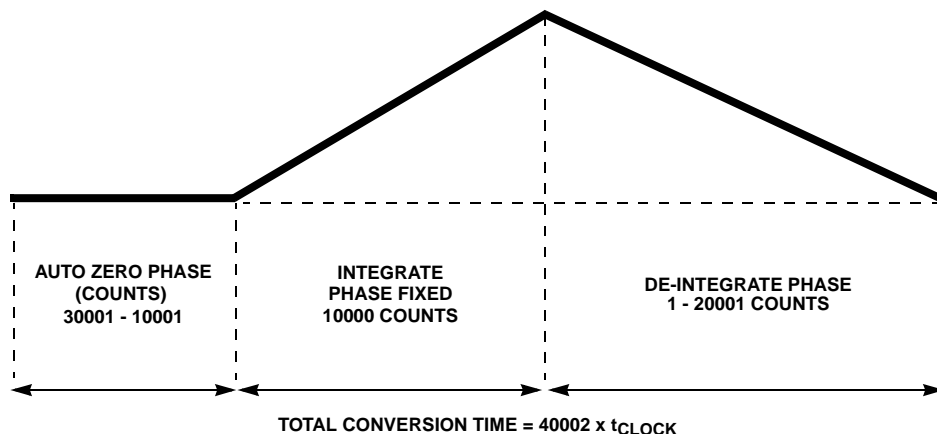

ICL7135

Die Characteristics

DIE DIMENSIONS:

(120 mils x 130 mils) x 525 μ m \pm 25 μ m

METALLIZATION:

Type: Al

Thickness: 10k \AA \pm 1k \AA

PASSIVATION:

Type: Nitride/Silox Sandwich

Thickness: 8k Nitride over 7k Silox

Metallization Mask Layout

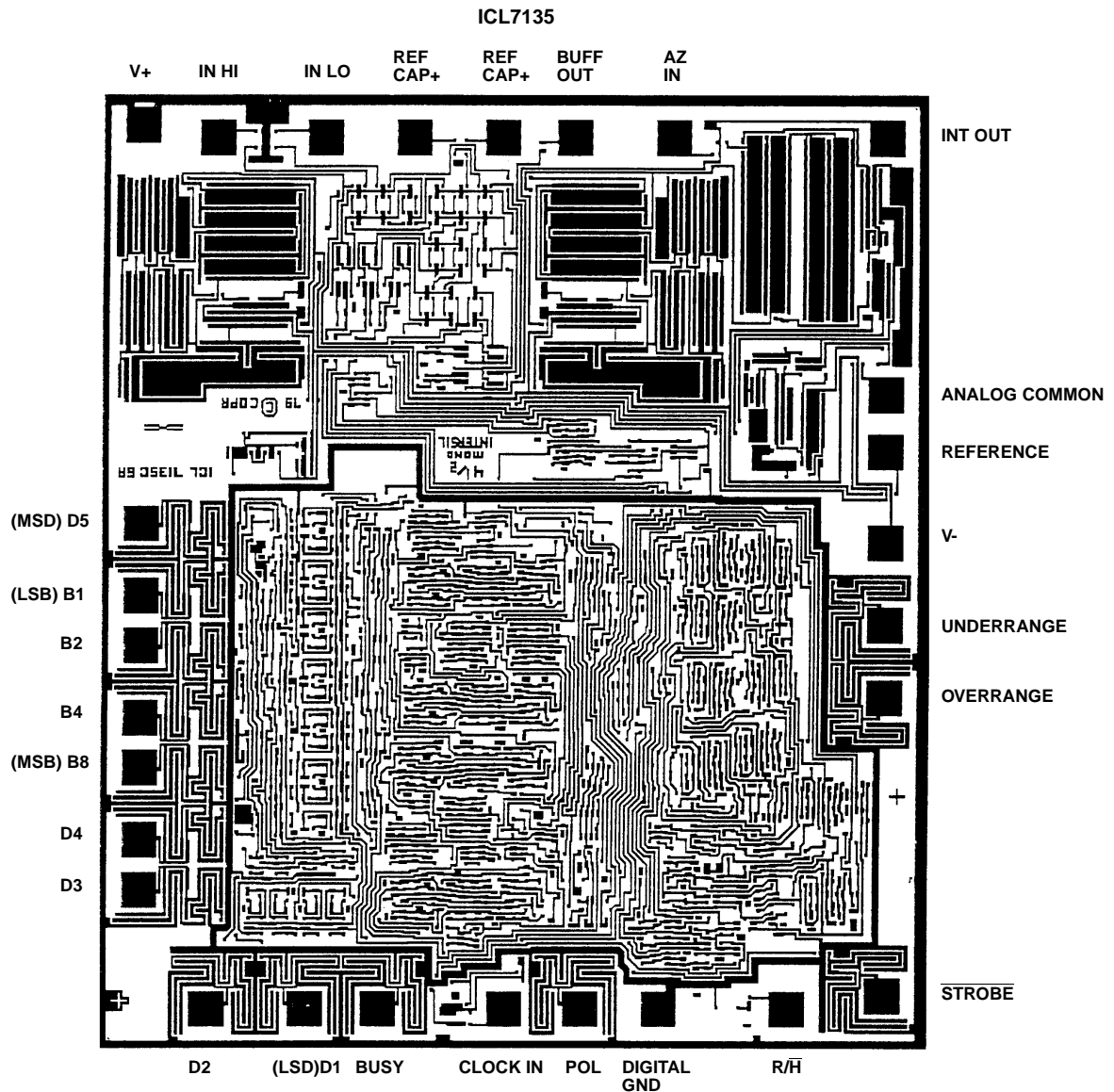

ICL7135

Dual-In-Line Plastic Packages (PDIP)

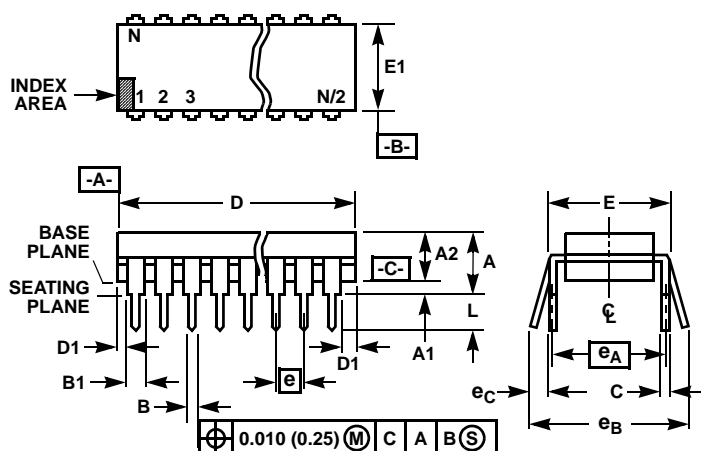

NOTES:

- Controlling Dimensions: INCH. In case of conflict between English and Metric dimensions, the inch dimensions control.
- Dimensioning and tolerancing per ANSI Y14.5M-1982.
- Symbols are defined in the "MO Series Symbol List" in Section 2.2 of Publication No. 95.
- Dimensions A, A1 and L are measured with the package seated in JEDEC seating plane gauge GS-3.
- D, D1, and E1 dimensions do not include mold flash or protrusions. Mold flash or protrusions shall not exceed 0.010 inch (0.25mm).
- E and e_A are measured with the leads constrained to be perpendicular to datum $-C-$.
- e_B and e_C are measured at the lead tips with the leads unconstrained. e_C must be zero or greater.
- B1 maximum dimensions do not include dambar protrusions. Dambar protrusions shall not exceed 0.010 inch (0.25mm).
- N is the maximum number of terminal positions.
- Corner leads (1, N, N/2 and N/2 + 1) for E8.3, E16.3, E18.3, E28.3, E42.6 will have a B1 dimension of 0.030 - 0.045 inch (0.76 - 1.14mm).

E28.6 (JEDEC MS-011-AB ISSUE B) 28 LEAD DUAL-IN-LINE PLASTIC PACKAGE

SYMBOL	INCHES		MILLIMETERS		NOTES
	MIN	MAX	MIN	MAX	
A	-	0.250	-	6.35	4
A1	0.015	-	0.39	-	4
A2	0.125	0.195	3.18	4.95	-
B	0.014	0.022	0.356	0.558	-
B1	0.030	0.070	0.77	1.77	8
C	0.008	0.015	0.204	0.381	-
D	1.380	1.565	35.1	39.7	5
D1	0.005	-	0.13	-	5
E	0.600	0.625	15.24	15.87	6
E1	0.485	0.580	12.32	14.73	5
e	0.100 BSC		2.54 BSC		-
e_A	0.600 BSC		15.24 BSC		6
e_B	-	0.700	-	17.78	7
L	0.115	0.200	2.93	5.08	4
N	28		28		9

Rev. 1 12/00

All Intersil U.S. products are manufactured, assembled and tested utilizing ISO9000 quality systems.
Intersil Corporation's quality certifications can be viewed at www.intersil.com/design/quality

Intersil products are sold by description only. Intersil Corporation reserves the right to make changes in circuit design, software and/or specifications at any time without notice. Accordingly, the reader is cautioned to verify that data sheets are current before placing orders. Information furnished by Intersil is believed to be accurate and reliable. However, no responsibility is assumed by Intersil or its subsidiaries for its use; nor for any infringements of patents or other rights of third parties which may result from its use. No license is granted by implication or otherwise under any patent or patent rights of Intersil or its subsidiaries.

For information regarding Intersil Corporation and its products, see www.intersil.com