



March 2001

CLC001 Serial Digital Cable Driver with Adjustable Outputs

General Description

The CLC001 is a monolithic, high-speed cable driver designed for use in SMPTE 259M serial digital video and ITU-T G.703 serial digital data transmission applications. The CLC001 drives 75Ω transmission lines (Belden 8281 or equivalent) at data rates up to 622 Mbps. Controlled output rise and fall times (400 ps typical) minimize transition-induced jitter. The output voltage swing is adjustable from 800 mV_{p-p} to 1.0 V_{p-p} using an external resistor.

The CLC001's output stage consumes less power than other designs. The differential inputs accept LVDS signal levels, LVPECL levels directly or PECL with attenuation networks.

All these make the CLC001 an excellent general purpose high speed driver for high-speed, long distance data transmission applications.

The CLC001 is powered from a single +3.3V supply and comes in a small 8-pin SOIC package.

Key Specifications

- 400 ps rise and fall times
- Data rates to 622 Mbps
- 100 mV differential input threshold
- Low residual jitter

Features

- Adjustable output amplitude
- Differential input and output
- Accepts LVPECL or LVDS input swings
- Low power dissipation
- Single +3.3V supply

Applications

- Digital routers and distribution amplifiers
- Coaxial cable driver for digital transmission lines
- Twisted pair driver
- Serial digital video interfaces for the commercial and broadcast industry
- SMPTE, Sonet/SDH, and ATM compatible driver
- Buffer applications

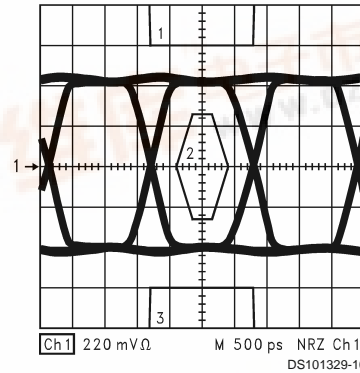

622 Mbps Eye Pattern with STM-4 Signal Mask

Connection Diagram (8-Pin SOIC)

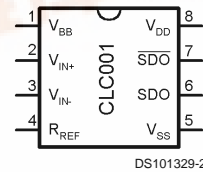

Order Number CLC001AJE
See NS Package Number M08A

Typical Application

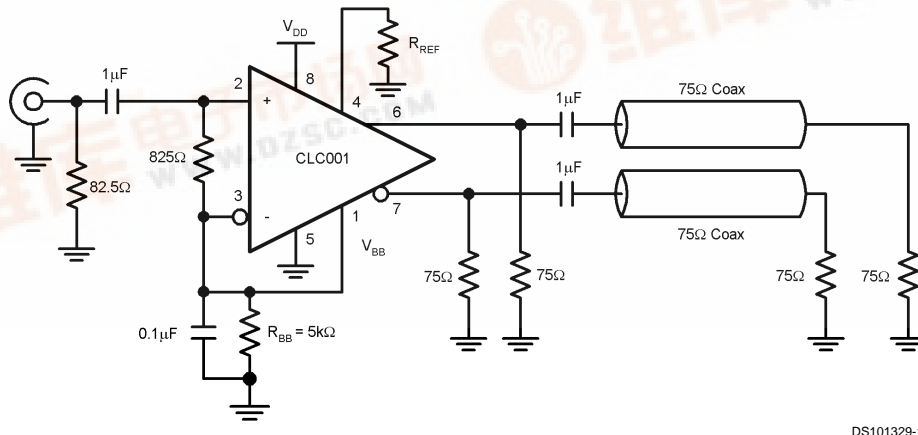

DS101329-1

CLC001 Serial Digital Cable Driver with Adjustable Outputs



Absolute Maximum Ratings (Note 1)

If Military/Aerospace specified devices are required, please contact the National Semiconductor Sales Office/Distributors for availability and specifications.

Supply Voltage	4V
Output Current	27 mA
Maximum Junction Temperature	+125°C
Storage Temperature Range	-65°C to +150°C
Lead Temperature (Soldering 10 seconds)	+300°C

ESD Rating (HBM)	≥ 7 kV
ESD Rating (MM)	≥ 500V
Package Thermal Resistance θ_{JA} Surface Mount AJE	125°C/W
θ_{JC} Surface Mount AJE	105°C/W
Reliability Information Transistor count	291

Recommended Operating Conditions

Supply Voltage Range ($V_{DD} - V_{SS}$)	+3.0V to +3.6V
Operating Free Air Temperature (T_A)	-40°C to +85°C
R_{BB} Range (applied to V_{BB} input) (Note 6)	1.3k Ω to 11.5k Ω

Electrical Characteristics

Over recommended operating supply and temperature ranges unless otherwise specified (Notes 2 and 3)

Symbol	Parameter	Conditions	Min	Typ	Max	Units
OUTPUT DC SPECIFICATIONS						
V_{SDO}	Serial Driver Output Voltage	$R_L = 75\Omega$ 1%, $R_{REF} = 1.91\text{ k}\Omega$ 1% (for 800 mV _{p-p}), Figure 1	720	800	880	mV
		$R_L = 75\Omega$ 1%, $R_{REF} = 1.5\text{ k}\Omega$ 1% (for 1.0 V _{p-p}), Figure 1	900	1000	1100	mV
INPUT DC SPECIFICATIONS						
V_{TH}	Differential Input High Threshold	$V_{CM} = +0.05V$ or +1.2V or +3.25V, $V_{DD} = 3.3V$		0	+100	mV
V_{TL}	Differential Input Low Threshold		-100	0		mV
V_{CMR}	Common Mode Voltage Range	$V_{ID} = 100\text{mV}$, $V_{DD} = 3.3V$	0.05		3.25	V
I_{IN}	Input Current	$V_{IN} = 0V$ or +3.0V, $V_{DD} = 3.6V$ or 0V		±1	±10	μA
I_{INB}	Input Current Balance	$V_{IN} = 0V$ or +3.0V, $V_{DD} = 3.6V$ or 0V, (Note 8)		0.23		μA
SUPPLY CURRENT						
I_{DD}	Total Dynamic Power Supply Current (includes load current)	$R_L = 75\Omega$, $R_{REF} = 1.91\text{ k}\Omega$ 1% ($V_{SDO} = 800\text{ mV}_{p-p}$ @ 270 Mbps)		70	115	mA
		$R_L = 75\Omega$, $R_{REF} = 1.5\text{ k}\Omega$ 1% ($V_{SDO} = 1.0\text{ V}_{p-p}$ @ 622 Mbps)		85	130	mA
MISCELLANEOUS PARAMETERS						
L_{GEN}	Output Inductance			6		nH
R_{GEN}	Output Resistance			25		k Ω
I_{BB}	V_{BB} Current	$R_{REF} = 1.91\text{ k}\Omega$ 1%, (Note 6)		250		μA
		$R_{REF} = 1.5\text{ k}\Omega$ 1%, (Note 6)		315		μA

AC Electrical Characteristics

Over recommended operating supply and temperature ranges unless otherwise specified (Note 3)

Symbol	Parameter	Conditions	Min	Typ	Max	Units
t_r, t_f	Rise time, Fall time	20%–80%, (Notes 4, 5)		400	800	ps
t_{os}	Output overshoot			5		%
t_{jit}	Output jitter	(Note 7)		25		ps
t_{pd}	Propagation delay	(Note 5)		1.9		ns

Note 1: “Absolute Maximum Ratings” are those values beyond which the safety of the device cannot be guaranteed. They are not meant to imply that the devices should be operated at these limits. The table of “Electrical Characteristics” specifies conditions of device operation.

Note 2: Current flow into device pins is defined as positive. Current flow out of device pins is defined as negative. All voltages are stated referenced to $V_{SS} = 0V$.

Note 3: Typical values are at 25°C and 3.3V.

Note 4: This parameter is Guaranteed by Design.

Note 5: $R_L = 75\Omega$, AC-coupled at 270 Mbps, $R_{REF} = 1.91\text{ k}\Omega$ 1% (for $V_{SDO} = 800\text{ mV}_{p-p} \pm 10\%$), C_L not greater than 5pF (See Figure 1)

Note 6: The V_{BB} output is intended as a bias supply pin for the inputs of this device only. It is not designed as a power supply output and should not be used to power other devices.

Note 7: $R_L = 75\Omega$, AC-coupled at 622 Mbps, $R_{REF} = 1.5\text{ k}\Omega$ 1% (for $V_{SDO} = 1.0\text{ V}_{p-p} \pm 10\%$), clock pattern input.

Note 8: Input Current Balance (I_{INB}) is the difference between the Input Current (I_{IN}) on V_{IN+} and V_{IN-} for the same bias condition.

Test Loads

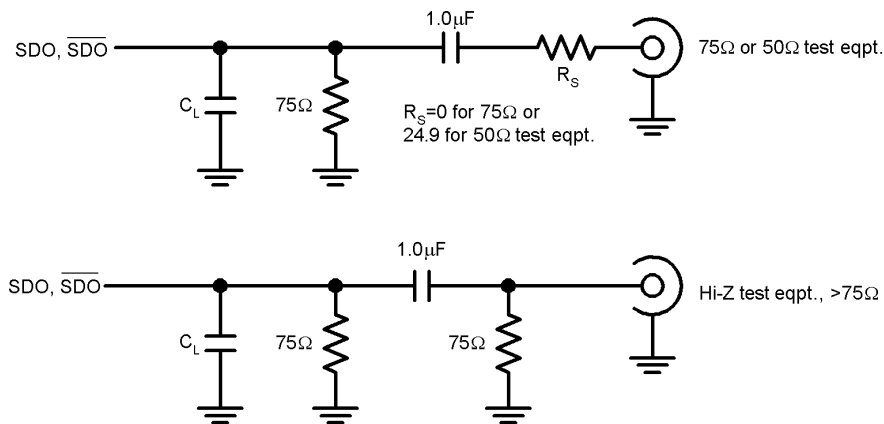

C_L represents probe and test fixture capacitance and is not greater than 5pF.

DS101329-4

FIGURE 1. Test Loads

Test Loads (Continued)

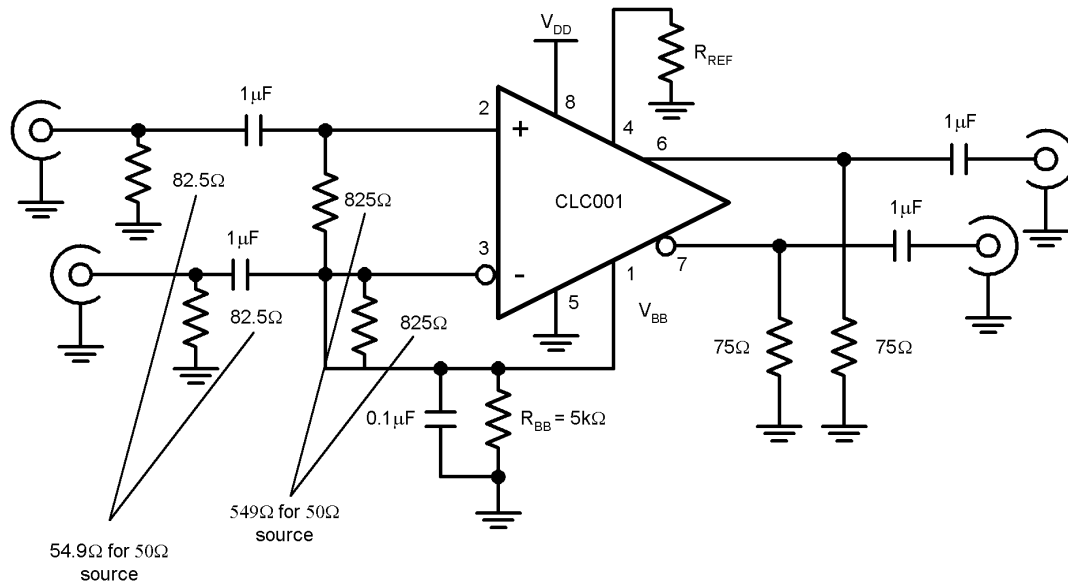

DS101329-3

FIGURE 2. Test Circuit

Pin Descriptions

Pin #	Name	Description
1	V_{BB}	Optional, bias voltage (may be used to bias inputs) - see device operation section for details. If unused leave as no connect (NC).
2	V_{IN+}	Positive input pin
3	V_{IN-}	Negative input pin
4	R_{REF}	Output driver level control. Connect a resistor to ground to set output voltage swing.
5	V_{SS}	Negative power supply
6	\overline{SDO}	Serial data true output
7	\overline{SDO}	Serial data complement output
8	V_{DD}	Positive power supply

Device Operation

INPUT INTERFACING

Numerous input configurations exist for applying PECL, LVPECL, and LVDS signals to the input of the CLC001. Inputs may be single-ended or differential, AC or DC coupled.

The V_{BB} pin may be used to provide a DC bias voltage to the inputs. Leave this pin as a no connect when no bias is needed. Note that DC-coupled inputs such as direct LVDS and LVPECL connections are self-biasing and do not require use of the V_{BB} pin. I_{BB} , the current produced by the V_{BB} pin, depends on R_{REF} . For a given R_{REF} , the I_{BB} current will remain constant, and the bias voltage is determined by the value of resistance, R_{BB} , between the V_{BB} pin and ground. *Figure 3* and *Figure 4* show how R_{BB} corresponds to some common V_{BB} values with R_{REF} held at 1.91 k Ω and 1.5 k Ω , respectively. Some common input configurations are shown in *Figure 5* through *Figure 9*.

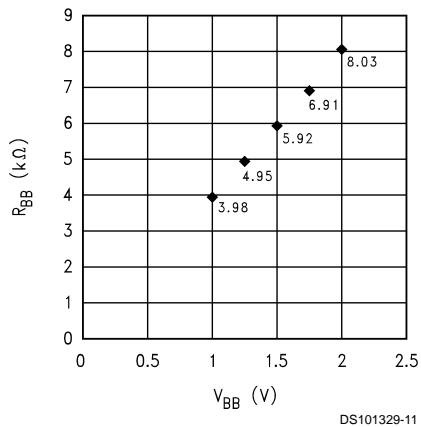

FIGURE 3. R_{BB} vs. V_{BB} for $R_{REF} = 1.91$ k Ω

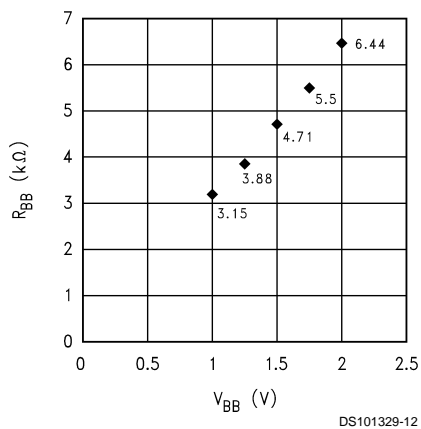
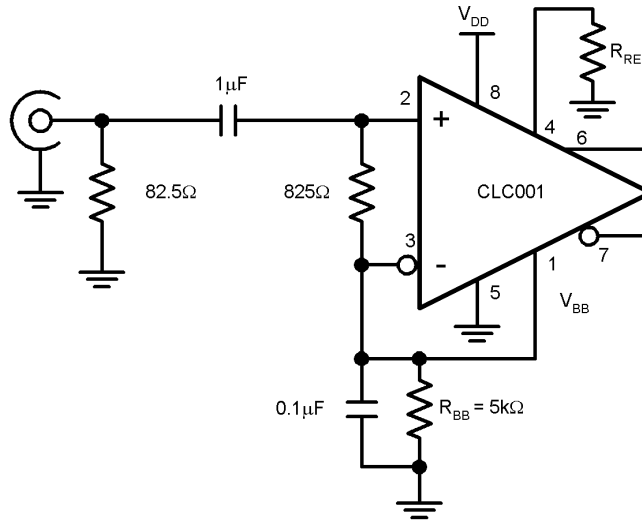

FIGURE 4. R_{BB} vs. V_{BB} for $R_{REF} = 1.5$ k Ω

Device Operation (Continued)

Figure 5 shows the CLC001 with an AC-coupled, single ended input connection. The 82.5Ω resistor in parallel

with 825Ω gives the equivalent termination resistance of 75Ω. R_{BB} set at 5kΩ provides 1.25V of DC bias to the input.



DS101329-5

FIGURE 5. Single Ended 75Ω Coaxial Cable, AC-coupled

A typical DC-coupled, twisted pair cable connection is shown in Figure 6. The CLC001 is driven differentially. The line is terminated with a termination resistor equal to the impedance of the line being driven. The actual resistor value is media specific, but typically is between 100 and

120Ω depending upon the cable. This resistor should be located close to the CLC001 inputs pins to minimize the resulting stub length between the resistor and device pads.

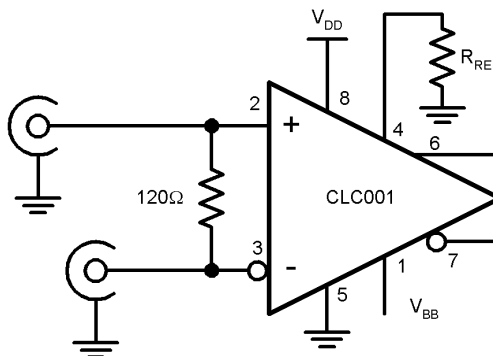

DS101329-6

FIGURE 6. Twisted Pair Cable, DC-coupled

Device Operation (Continued)

Figure 7 shows an AC-coupled, twisted pair cable application. It implements a center tap capacitance

termination used in conjunction with two 50Ω resistors to filter common mode noise. R_{BB} set at 5kΩ provides 1.25V of DC bias to each input.

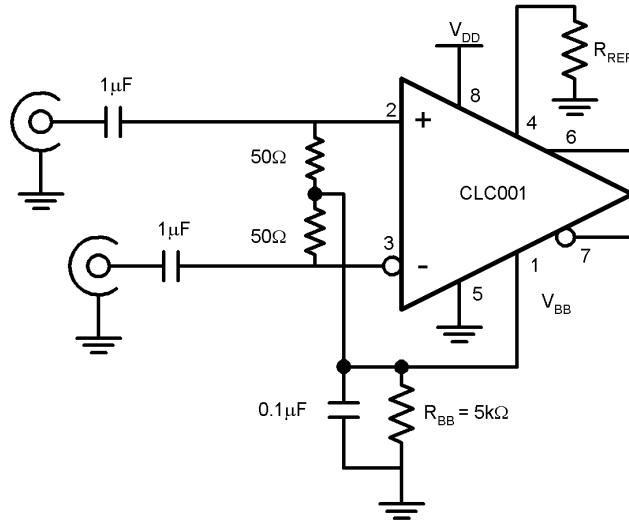

DS101329-7

FIGURE 7. Twisted Pair Cable, AC-coupled

PECL or LVPECL drivers may be interfaced to the CLC001 as shown in Figure 8. The voltage divider network will reduce the PECL output to the proper levels. For LVPECL, the 100Ω series resistors should be

removed, since the common mode range inputs of the CLC001 are wide enough to accept LVPECL levels directly. No external DC biasing is required for PECL/LVPECL connections.

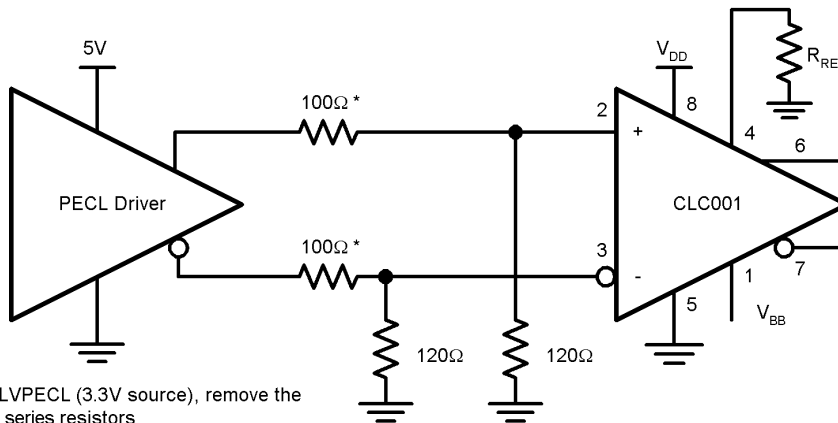

* For LVPECL (3.3V source), remove the 100Ω series resistors

DS101329-8

FIGURE 8. PECL, DC-coupled

Device Operation (Continued)

A typical LVDS input connection is shown in *Figure 9*. The media is driven differentially by an LVDS driver. The line is terminated with a termination resistor equal to the impedance of the line being driven. The actual resistor value is media specific, but typically is between 100 and

120 Ω . This resistor should be located close to the CLC001 inputs pins to minimize the resulting stub length between the resistor and device pads. The CLC001 supports $\pm 100\text{mV}$ thresholds across the entire LVDS common mode range of 0.1V to 2.3V for a 200mV differential signal.

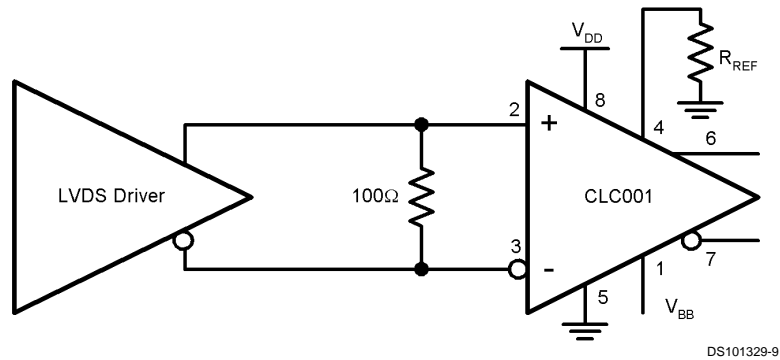

FIGURE 9. LVDS, DC-coupled

Device Operation (Continued)

OUTPUT INTERFACING

The CLC001 has two complementary, ground referenced outputs designed to drive AC-coupled and terminated 75Ω coaxial cables. The outputs are single ended; however, they could be treated as a single differential output as long as current paths from each output go to ground.

The output of the CLC001 is a high impedance current source. It expects to see a 75Ω shunt resistor before driving cable to convert the current output to a voltage and provide proper back-matching. No series back-matching resistors should be used. Refer to *Typical Application* for an illustration.

Output levels range from 800 mV_{p-p} to 1.0 V_{p-p} ±10% into 75Ω AC-coupled, back-matched loads. Output level is controlled by the value of R_{REF} connected to pin 4. R_{REF} is 1.91 kΩ ±1% for 800 mV_{p-p}, and 1.5 kΩ ±1% for 1.0 V_{p-p}. Refer to *Figure 10* for the output level's sensitivity to R_{REF}.

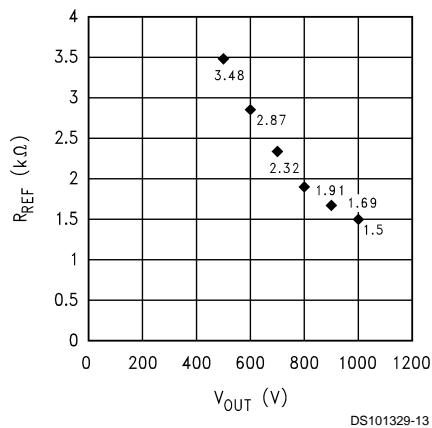

FIGURE 10. Output level's sensitivity to R_{REF}

The CLC001 is designed as an AC-coupled 75Ω cable driver. It is not intended to drive 50Ω loads. The current source output does not provide enough current to allow for 800mV across a 50Ω doubly terminated load.

Evaluation Board

Evaluation boards are available for a nominal charge that demonstrate the basic operation of the SDI/SDV/SDH devices. The evaluation boards can be ordered through National's Distributors. Supplies are limited, please check for current availability.

The SD001EVK evaluation kit for the CLC001, Serial Digital Cable Driver with Adjustable Outputs, provides an operating environment in which the cable driver can be evaluated by system / hardware designers. The evaluation board has all the needed circuitry and connectors for easy connection and checkout of the device circuit options as discussed in the CLC001 datasheet. A schematic, parts list and pictorial drawing are provided with the board.

From the WWW, the following information may be viewed / downloaded for most evaluation boards: www.national.com/appinfo/interface

- Device Datasheet and / or EVK User Manual
- View a picture of the EVK
- View the EVK Schematic
- View the top assembly drawing and BOM
- View the bottom assembly drawing and BOM

PCB Layout Recommendations

Printed circuit board layout affects the performance of the CLC001. The following guidelines will aid in achieving satisfactory device performance.

- Use a ground plane or power/ground plane sandwich design for optimum performance.
- Bypass device power with a 0.01 μF monolithic ceramic capacitor in parallel with a 6.8 μF tantalum electrolytic capacitor located no more than 0.1" (2.5 mm) from the device power pins.
- Provide short, symmetrical ground return paths for:
 - inputs,
 - supply bypass capacitors and
 - the output load.
- Provide short, grounded guard traces located
 - under the centerline of the package,
 - 0.1" (2.5 mm) from the package pins
 - on both top and bottom of the board with connecting vias.

Physical Dimensions inches (millimeters) unless otherwise noted

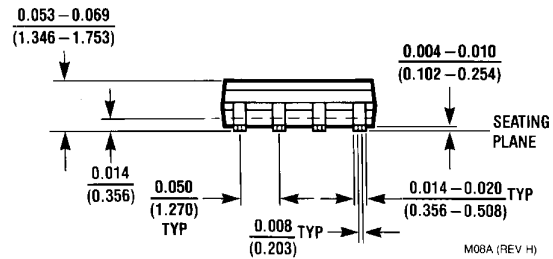
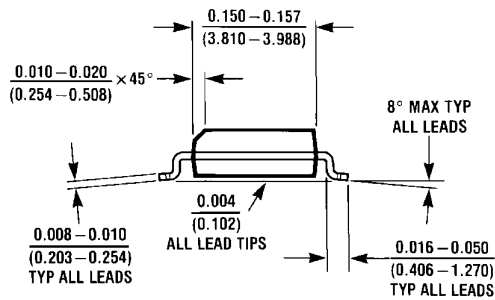
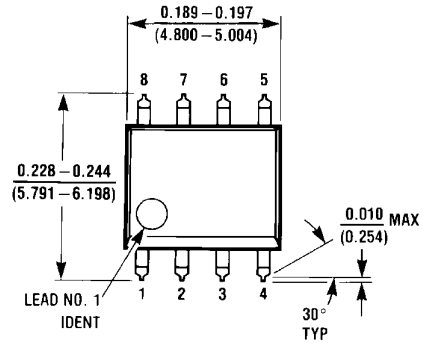

Order Number CLC001AJE
NS Package Number M08A

LIFE SUPPORT POLICY

NATIONAL'S PRODUCTS ARE NOT AUTHORIZED FOR USE AS CRITICAL COMPONENTS IN LIFE SUPPORT DEVICES OR SYSTEMS WITHOUT THE EXPRESS WRITTEN APPROVAL OF THE PRESIDENT AND GENERAL COUNSEL OF NATIONAL SEMICONDUCTOR CORPORATION. As used herein:

1. Life support devices or systems are devices or systems which, (a) are intended for surgical implant into the body, or (b) support or sustain life, and whose failure to perform when properly used in accordance with instructions for use provided in the labeling, can be reasonably expected to result in a significant injury to the user.
2. A critical component is any component of a life support device or system whose failure to perform can be reasonably expected to cause the failure of the life support device or system, or to affect its safety or effectiveness.



National Semiconductor Corporation
Americas
Tel: 1-800-272-9959
Fax: 1-800-737-7018
Email: support@nsc.com
www.national.com

National Semiconductor Europe
Fax: +49 (0) 180-530 85 86
Email: europe.support@nsc.com
Deutsch Tel: +49 (0) 69 9508 6208
English Tel: +44 (0) 870 24 0 2171
Français Tel: +33 (0) 1 41 91 8790

National Semiconductor Asia Pacific Customer Response Group
Tel: 65-2544466
Fax: 65-2504466
Email: ap.support@nsc.com

National Semiconductor Japan Ltd.
Tel: 81-3-5639-7560
Fax: 81-3-5639-7507