

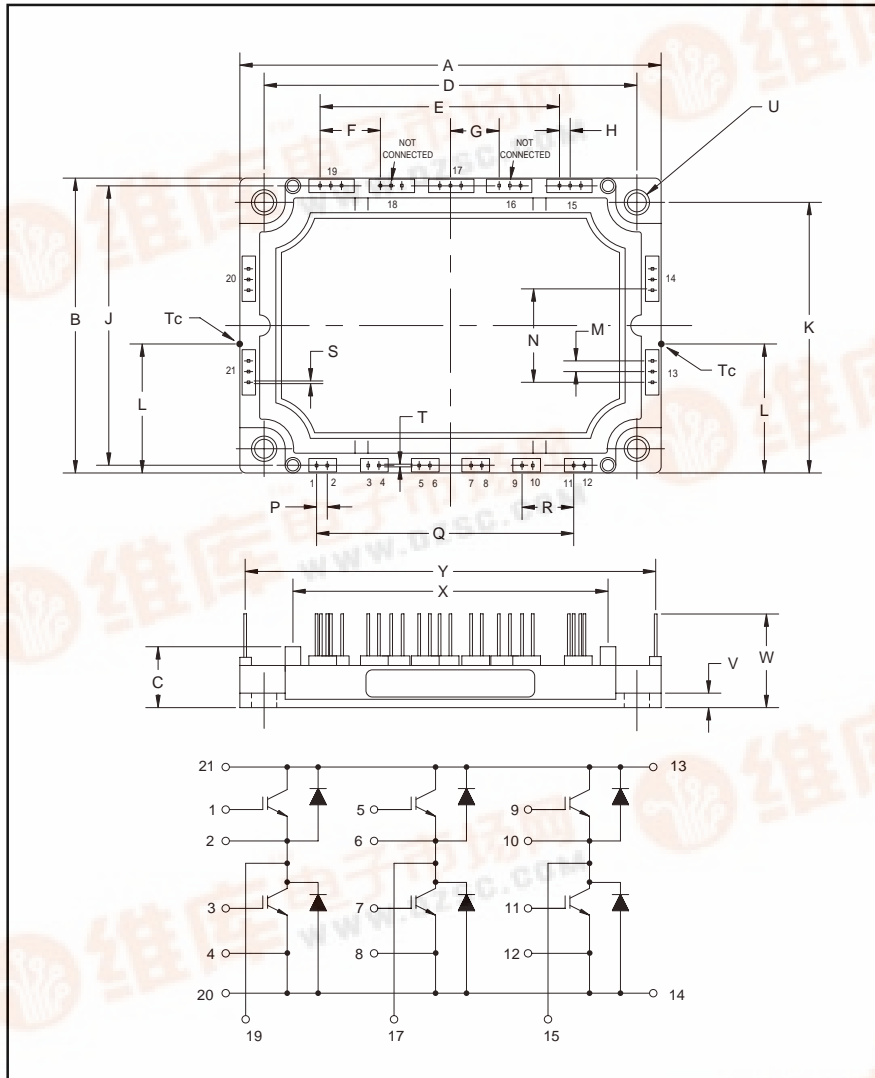

Powerex, Inc., 200 Hillis Street, Youngwood, Pennsylvania 15697-1800 (724) 925-7272

CM75TJ-24F

Trench Gate Design Six IGBTMOD™ 75 Amperes/1200 Volts



Outline Drawing and Circuit Diagram

Dimensions	Inches	Millimeters
A	4.78	121.5
B	2.42	61.5
C	0.67	17.0
D	4.33±0.01	110.0±0.25
E	3.00	76.2
F	0.75	19.05
G	0.60	15.24
H	0.15	3.81
J	2.26	57.5
K	1.97±0.01	50.0±0.25
L	1.07	27.0

Dimensions	Inches	Millimeters
M	0.15	3.81
N	0.75	19.05
P	0.15	3.81
Q	3.00	76.2
R	0.60	15.24
S	0.45	1.15
T	0.04	1.0
U	0.22 Dia.	5.5 Dia.
V	0.12	3.0
W	0.81	20.5
X	3.72	94.5
Y	4.62	118.11



Description:

Powerex IGBTMOD™ Modules are designed for use in switching applications. Each module consists of six IGBT Transistors in a three phase bridge configuration, with each transistor having a reverse-connected super-fast recovery free-wheel diode. All components and interconnects are isolated from the heat sinking baseplate, offering simplified system assembly and thermal management.

Features:

- Low Drive Power
- Low $V_{CE(sat)}$
- Discrete Super-Fast Recovery Free-Wheel Diode
- Isolated Baseplate for Easy Heat Sinking

Applications:

- AC Motor Control
- UPS
- Battery Powered Supplies

Ordering Information:

Example: Select the complete module number you desire from the table - i.e. CM75TJ-24F is a 1200V (V_{CES}), 75 Ampere Six-IGBT IGBTMOD™ Power Module.

Type	Current Rating Amperes	V_{CES} Volts (x 50)
CM	75	24





Powerex, Inc., 200 Hillis Street, Youngwood, Pennsylvania 15697-1800 (724) 925-7272

CM75TJ-24F
Trench Gate Design Six IGBTMOD™
 75 Amperes/1200 Volts

Absolute Maximum Ratings, $T_j = 25\text{ }^\circ\text{C}$ unless otherwise specified

Ratings	Symbol	CM75TJ-24F	Units
Junction Temperature	T_j	-40 to 150	$^\circ\text{C}$
Storage Temperature	T_{stg}	-40 to 125	$^\circ\text{C}$
Collector-Emitter Voltage (G-E SHORT)	V_{CES}	1200	Volts
Gate-Emitter Voltage (C-E SHORT)	V_{GES}	± 20	Volts
Collector Current ($T_c = 25^\circ\text{C}$)	I_C	75	Amperes
Peak Collector Current ($T_j \leq 150^\circ\text{C}$)	I_{CM}	150*	Amperes
Emitter Current ($T_c = 25^\circ\text{C}$)**	I_E	75	Amperes
Peak Emitter Current**	I_{EM}	150*	Amperes
Maximum Collector Dissipation ($T_j < 150^\circ\text{C}$) ($T_c = 25^\circ\text{C}$)	P_c	357	Watts
Mounting Torque, M5 Mounting	–	31	in-lb
Weight	–	300	Grams
Isolation Voltage (Main Terminal to Baseplate, AC 1 min.)	V_{iso}	2500	Volts

Static Electrical Characteristics, $T_j = 25\text{ }^\circ\text{C}$ unless otherwise specified

Characteristics	Symbol	Test Conditions	Min.	Typ.	Max.	Units
Collector-Cutoff Current	I_{CES}	$V_{CE} = V_{CES}, V_{GE} = 0V$	–	–	1	mA
Gate Leakage Current	I_{GES}	$V_{GE} = V_{GES}, V_{CE} = 0V$	–	–	20	μA
Gate-Emitter Threshold Voltage	$V_{GE(th)}$	$I_C = 7.5\text{mA}, V_{CE} = 10V$	5	6	7	Volts
Collector-Emitter Saturation Voltage	$V_{CE(sat)}$	$I_C = 75A, V_{GE} = 15V, T_j = 25^\circ\text{C}$	–	1.8	2.4	Volts
		$I_C = 75A, V_{GE} = 15V, T_j = 125^\circ\text{C}$	–	1.9	–	Volts
Total Gate Charge	Q_G	$V_{CC} = 600V, I_C = 75A, V_{GE} = 15V$	–	825	–	nC
Emitter-Collector Voltage**	V_{EC}	$I_E = 75A, V_{GE} = 0V$	–	–	3.3	Volts

* Pulse width and repetition rate should be such that the device junction temperature (T_j) does not exceed $T_{j(max)}$ rating.

** Represents characteristics of the anti-parallel, emitter-to-collector free-wheel diode (FWDi).



Powerex, Inc., 200 Hillis Street, Youngwood, Pennsylvania 15697-1800 (724) 925-7272

CM75TJ-24F
Trench Gate Design Six IGBTMOD™
 75 Amperes/1200 Volts

Dynamic Electrical Characteristics, $T_j = 25\text{ }^\circ\text{C}$ unless otherwise specified

Characteristics	Symbol	Test Conditions	Min.	Typ.	Max.	Units
Input Capacitance	C_{ies}		–	–	29	nf
Output Capacitance	C_{oes}	$V_{CE} = 10V, V_{GE} = 0V, f = 1MHz$	–	–	1.3	nf
Reverse Transfer Capacitance	C_{res}		–	–	1.2	nf
Inductive Load	Turn-on Delay Time	$V_{CC} = 600V,$ $I_C = 75A,$	–	–	100	ns
	Rise Time					
Switch Times	Turn-off Delay Time	$V_{GE1} = V_{GE2} = 15V,$ $R_G = 4.2\Omega,$	–	–	400	ns
	Fall Time					
Diode Reverse Recovery Time**	t_{rr}	Inductive Load	–	–	150	ns
Diode Reverse Recovery Charge**	Q_{rr}	Switching Operation	–	3.1	–	μC

Thermal and Mechanical Characteristics, $T_j = 25\text{ }^\circ\text{C}$ unless otherwise specified

Characteristics	Symbol	Test Conditions	Min.	Typ.	Max.	Units
Thermal Resistance, Junction to Case	$R_{th(j-c)Q}$	Per IGBT 1/6 Module, T_C Reference Point per Outline Drawing	–	–	0.35	$^\circ\text{C/W}$
Thermal Resistance, Junction to Case	$R_{th(j-c)D}$	Per FWDi 1/6 Module, T_C Reference Point per Outline drawing	–	–	0.47	$^\circ\text{C/W}$
Thermal Resistance, Junction to Case	$R_{th(j-c)'Q}$	Per IGBT 1/6 Module, T_C Reference Point Under Chip	–	0.22	–	$^\circ\text{C/W}$
Thermal Resistance, Junction to Case	$R_{th(j-c)'D}$	Per FWDi 1/6 Module, T_C Reference Point Under Chip	–	0.25	–	$^\circ\text{C/W}$
Contact Thermal Resistance	$R_{th(c-f)}$	Per Module, Thermal Grease Applied	–	0.13	–	$^\circ\text{C/W}$

** Represents characteristics of the anti-parallel, emitter-to-collector free-wheel diode (FWDi).



Powerex, Inc., 200 Hillis Street, Youngwood, Pennsylvania 15697-1800 (724) 925-7272

CM75TJ-24F
Trench Gate Design Six IGBTMOD™
 75 Amperes/1200 Volts

