

# 6-PIN PHOTOTRANSISTOR OPTOCOUPLERS

## CNX82A.W, CNX83A.W, SL5582.W & SL5583.W

### DESCRIPTION

The CNX82A.W, CNX83A.W, SL5582.W AND SL5583.W, consist of a gallium arsenide infrared emitting diode driving a silicon phototransistor in a 6-pin dual in-line package.

### FEATURES

- Input/Output pin distance 10.16 mm
- UL recognized (File # E90700)

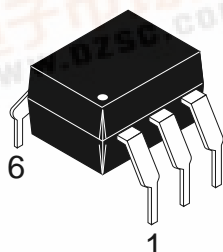

### APPLICATIONS

- Power supply regulators
- Digital logic inputs
- Microprocessor inputs

#### SCHEMATIC

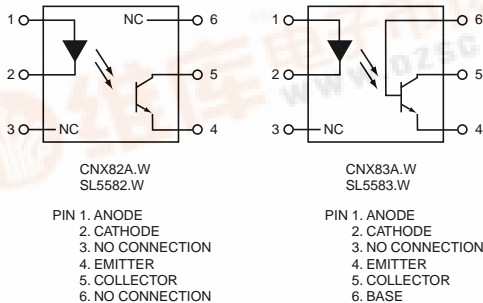

### PACKAGE DIMENSIONS

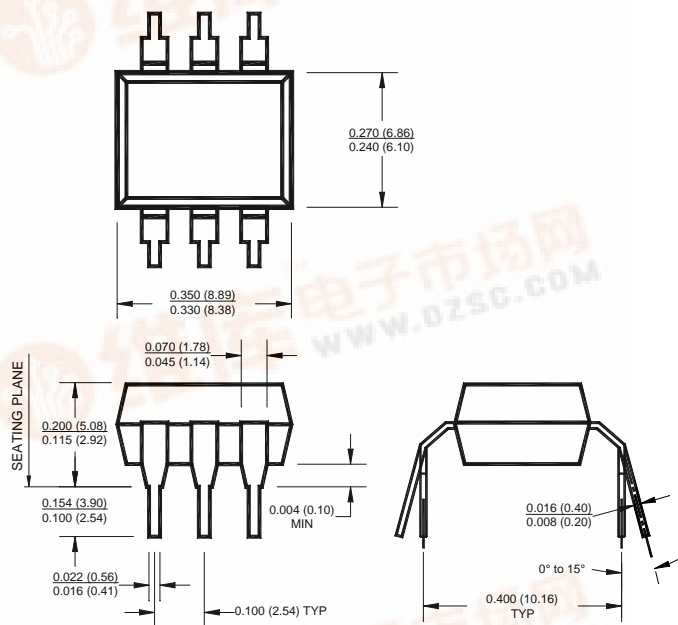

#### NOTE

All dimensions are in inches (millimeters)

### ABSOLUTE MAXIMUM RATINGS

Parameter	Symbol	Value	Units
<b>TOTAL DEVICE</b>			
Storage Temperature	$T_{STG}$	-55 to +150	°C
Operating Temperature	$T_{OPR}$	-55 to +100	°C
Lead Solder Temperature	$T_{SOL}$	260 for 10 sec	°C
Junction Temperature	$T_J$	125	°C
Total Device Power Dissipation @ $T_A = 25^\circ\text{C}$	$P_D$	250	mW
<b>EMITTER</b>			
DC/Average Forward Input Current	$I_F$	100	mA
Reverse Input Voltage	$V_R$	5.0	V
Forward Current - Peak (1 $\mu\text{s}$ pulse, 300pps)	$I_F(pk)$	3.0	A
LED Power Dissipation @ $T_A = 25^\circ\text{C}$	$P_D$	140	mW
Derate above 25°C		1.33	mW/°C
<b>DETECTOR</b>			
Collector-Emitter Voltage	$V_{CEO}$	50	V
Collector-Base Voltage (CNX83A)	$V_{CBO}$	70	V
Emitter-Collector Voltage	$V_{ECO}$	7	V
Continuous Collector Current	$I_C$	100	mA
Detector Power Dissipation @ $T_A = 25^\circ\text{C}$	$P_D$	150	mW
Derate above 25°C		2.0	mW/°C



# 6-PIN PHOTOTRANSISTOR OPTOCOUPLEDERS

## CNX82A.W, CNX83A.W, SL5582.W & SL5583.W

### ELECTRICAL CHARACTERISTICS ( $T_A = 25^\circ\text{C}$ Unless otherwise specified.)

#### INDIVIDUAL COMPONENT CHARACTERISTICS

Parameter	Test Conditions	Symbol	Device	Min	Typ**	Max	Unit
<b>EMITTER</b>							
Input Forward Voltage	( $I_F = 10\text{ mA}$ )	$V_F$	ALL		1.2	1.50	V
Reverse Leakage Current	( $V_R = 5.0\text{ V}$ )	$I_R$	ALL		0.001	10	$\mu\text{A}$
<b>DETECTOR</b>							
Collector-Emitter Breakdown Voltage	( $I_C = 1.0\text{ mA}$ , $I_F = 0$ )	$BV_{CEO}$	ALL	50	100		V
Collector-Base Breakdown Voltage	( $I_C = 100\text{ }\mu\text{A}$ , $I_F = 0$ )	$BV_{CBO}$	CNX83A.W SL5583.W	70	120		V
Emitter-Collector Breakdown Voltage	( $I_E = 100\text{ }\mu\text{A}$ , $I_F = 0$ )	$BV_{ECO}$	ALL	7	10		V
Collector-Emitter Dark Current	(V <sub>CE</sub> = 10 V, I <sub>F</sub> = 0)	$I_{CEO}$	ALL		0.001	0.050	$\mu\text{A}$
			CNX82A.W CNX83A.W		0.5	10	
	(V <sub>CE</sub> = 10 V, I <sub>F</sub> = 0) (T <sub>A</sub> = 70°C)	SL5582.W SL5583.W			0.5		
		SL5582.W SL5583.W			50		
Collector-Base Dark Current	(V <sub>CB</sub> = 10 V)	$I_{CBO}$	CNX83A.W SL5583.W			20	nA
Capacitance	(V <sub>CE</sub> = 0 V, f = 1 MHz)	$C_{CE}$	ALL		8		pF

Note

\*\* Typical values at  $T_A = 25^\circ\text{C}$

Call QT Optoelectronics for more information or the phone number of your nearest distributor.

United States 800-533-6786 • France 33 [0] 1.45.18.78.78 • Germany 49 [0] 89/96.30.51 • United Kingdom 44 [0] 1296 394499 • Asia/Pacific 603-7352417



# 6-PIN PHOTOTRANSISTOR OPTOCOUPLEDERS

## CNX82A.W, CNX83A.W, SL5582.W & SL5583.W

TRANSFER CHARACTERISTICS (T <sub>A</sub> = 25°C Unless otherwise specified.)							
DC Characteristic	Test Conditions	Symbol	Device	Min	Typ**	Max	Units
Current Transfer Ratio, Collector-Emitter	(I <sub>F</sub> = 10 mA, V <sub>CE</sub> = 0.4 V)	CTR	ALL	40			%
	(I <sub>F</sub> = 10 mA, V <sub>CE</sub> = 5 V)		CNX82A.W CNX83A.W	40		250	
			SL5582.W SL5583.W	40		320	
	(I <sub>F</sub> = 10 mA, V <sub>CE</sub> = 5 V) (T <sub>A</sub> = 100°C)		SL5582.W SL5583.W	25		320	
	(I <sub>F</sub> = 1 mA, V <sub>CE</sub> = 5 V)		CNX82A.W CNX83A.W	10		100	
	(I <sub>F</sub> = 2 mA, V <sub>CE</sub> = 5 V)		SL5582.W SL5583.W	20			
	(I <sub>F</sub> = 2 mA, V <sub>CE</sub> = 5 V) (T <sub>A</sub> = 100°C)		SL5582.W SL5583.W	15			
Saturation Voltage	(I <sub>F</sub> = 10 mA, I <sub>C</sub> = 4 mA)	V <sub>CE(sat)</sub>	ALL		0.19	0.4	V
Turn-on Time	(I <sub>C</sub> = 2 mA, V <sub>CC</sub> = 5 V, R <sub>L</sub> = 100 Ω)	t <sub>on</sub>	ALL		3		μs
	(I <sub>C</sub> = 2 mA, V <sub>CC</sub> = 5 V, R <sub>L</sub> = 1 kΩ)		ALL		12		
	(I <sub>F</sub> = 16 mA, V <sub>CC</sub> = 5 V, R <sub>L</sub> = 1 kΩ)		SL5582.W SL5583.W			20	
Turn-off Time	(I <sub>C</sub> = 2 mA, V <sub>CC</sub> = 5 V, R <sub>L</sub> = 100 Ω)	t <sub>off</sub>	ALL		3		μs
	(I <sub>C</sub> = 2 mA, V <sub>CC</sub> = 5 V, R <sub>L</sub> = 1 kΩ)		ALL		12		
	(I <sub>F</sub> = 16 mA, V <sub>CC</sub> = 5 V, R <sub>L</sub> = 1 kΩ)		SL5582.W SL5583.W			50	

ISOLATION CHARACTERISTICS							
Characteristic	Test Conditions	Symbol	Min	Typ**	Max	Units	
Input-Output Isolation Voltage	(I <sub>I-O</sub> ≤ 1 μA, 1 min.)	V <sub>ISO</sub>	5300			Vac(rms)	
Isolation Resistance	(V <sub>I-O</sub> = 500 VDC)	R <sub>ISO</sub>	10 <sup>11</sup>			Ω	
Isolation Capacitance	(V <sub>I-O</sub> = ∅, f = 1 MHz)	C <sub>ISO</sub>		0.5		pf	
External air gap (clearance)			9.6			mm	
External tracking path (creepage)			8.0			mm	
Internal plastic gap (clearance)			1.0			mm	

Note

\*\* Typical values at T<sub>A</sub> = 25°C

## ORDERING INFORMATION

Option	Order Entry Identifier	Description
300	.300W	VDE 0884

## CNX82A.W, CNX83A.W, SL5582.W & SL5583.W

### TYPICAL CHARACTERISTICS

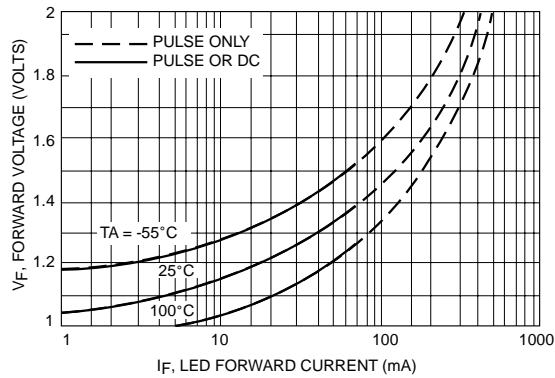

Figure 1. LED Forward Voltage versus Forward Current

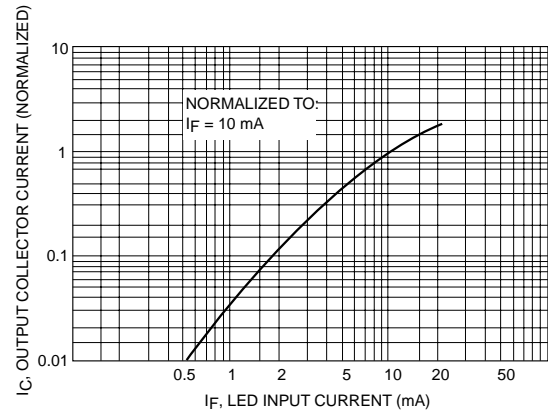

Figure 2. Output Current versus Input Current

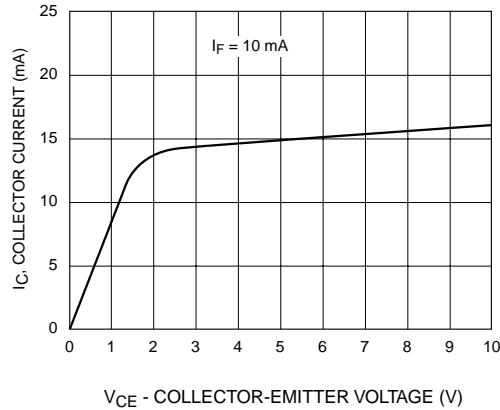

Figure 3. Collector Current versus Collector-Emitter Voltage

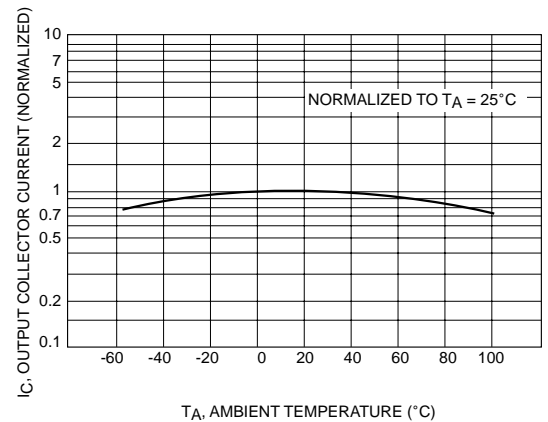

Figure 4. Output Current versus Ambient Temperature

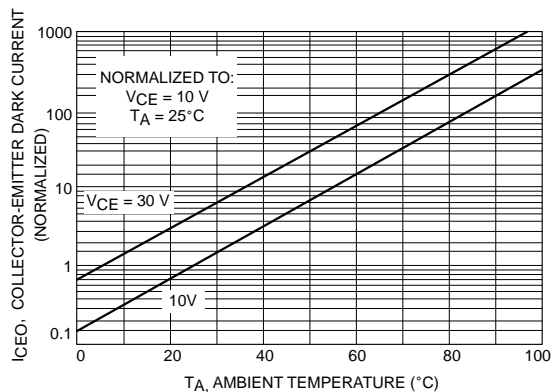

Figure 5. Dark Current versus Ambient Temperature

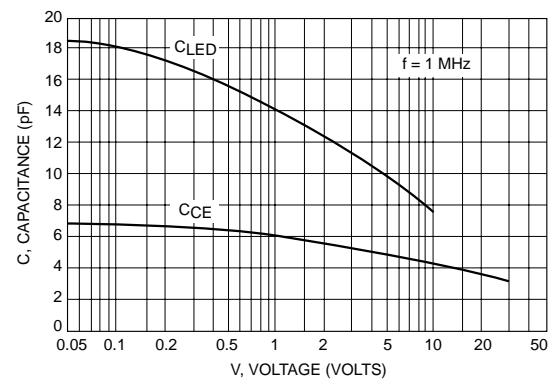

Figure 6. Capacitance versus Voltage