

# HD64180R/Z

查询IC64180R供应商

捷多邦，专业PCB打样工厂，24小时加

急出货

## 8-BIT CMOS (Micro Processing Unit)

Based on a microcoded execution unit and advanced CMOS manufacturing technology, the HD64180 is an 8-bit MPU which provides the benefits of high performance, reduced system cost and low power operation while maintaining compatibility with the large base of industry standard 8-bit software.

Performance is improved by virtue of high operating frequency, pipelining, enhanced instruction set and an integrated Memory Management Unit (MMU) with 1M or 512k bytes memory physical address space.

System cost is reduced by incorporating key system functions on-chip including the MMU, two channel refresh, two channel Asynchronous Serial Communication Interface (ASCI), Clocked Serial I/O Port (CSI/O), two channel 16-bit Programmable Reload Timer (PRT), Versatile I2 source interrupt controller and a 'dual' (68x x, 80x x) bus interface.

Low power consumption during normal CPU operation is supplemented by two specific software controlled low power operation modes.

The HD64180, when combined with CMOS VLSI memories and peripherals, is useful in system applications requiring high performance, battery power operation and standard software compatibility.

The HD64180Z is fully compatible with Z80180 (Z180) which is marketed by Zilog Inc.

### ■ Software Features

- Enhanced standard 8-bit software architecture:  
Upward compatible with CP/M-80®

### ■ Hardware Features

- On-chip MMU supporting 1M byte memory (Provided 512K byte for DP-64S).
- Two channel DMAC with memory-memory, memory-I/O and memory-memory mapped I/O transfer capabilities
- Two channel, full duplex asynchronous serial communication interface (ASC) with programmable baud rate generator and modem control handshake signals
- One channel clocked serial I/O port with serial/parallel shift register
- Two channel 16-bit programmable reload timer for output waveform generation
- Four external and eight internal interrupts
- Dual bus interface compatible with Motorola 68 family and with Intel 80 family
- On-chip clock generator
- Operating Frequency up to 10 MHz
- Low power dissipation: 50 mW at 4 MHz Operation (typ.)
- R = Interface with 63/68, 80xx peripherals
- Z = Interface with Z80 peripherals

HD64180RP  
HD64180ZP

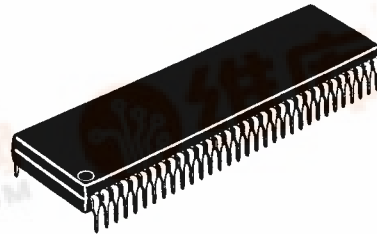

(DP-64S)

HD64180RCP  
HD64180ZCP

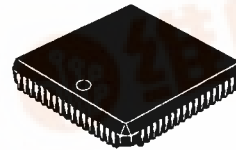

(CP-68)

HD64180RF  
HD64180ZF

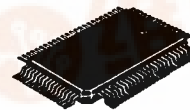

(FP-80B)

Pin Function Differences in the HD64180 Series

Package * Type	Pin No.	HD64180R1	HD64180Z
CP-68	18	V <sub>SS</sub>	V <sub>SS</sub>
	35	A <sub>19</sub>	A <sub>19</sub>
	52	NC	TEST
FP-80B	12	V <sub>SS</sub>	V <sub>SS</sub>
	33	A <sub>19</sub>	A <sub>19</sub>
	53	NC	TEST

\*"J" after package designation indicates industrial temperature parts.

HD64180R

Part No.	Clock Frequency (MHz)	Package Type	Address Space
HD64180RP-6	6	DP-64S	512 K Byte
HD64180RP-8	8		
HD64180RP-10	10		
HD64180RF-6X	6	FP-80	1 M Byte
HD64180RF-8X	8		
HD64180RF-10X	10		
HD64180RCP-6X	6	CP-68	1 M Byte
HD64180RCP-8X	8		
HD64180RCP-10X	10		

HD64180Z

Part No.	Clock Frequency (MHz)	Package Type	Address Space
HD64180ZP-6	6	DP-64S	512 K Byte
HD64180ZP-8	8		
HD64180ZP-10	10		
HD64180ZF-6X	6	FP-80	1 M Byte
HD64180ZF-8X	8		
HD64180ZF-10X	10		
HD64180ZCP-6X	6	CP-68	1 M Byte
HD64180ZCP-8X	8		
HD64180ZCP-10X	10		

■ PIN ASSIGNMENT

• HD64180R

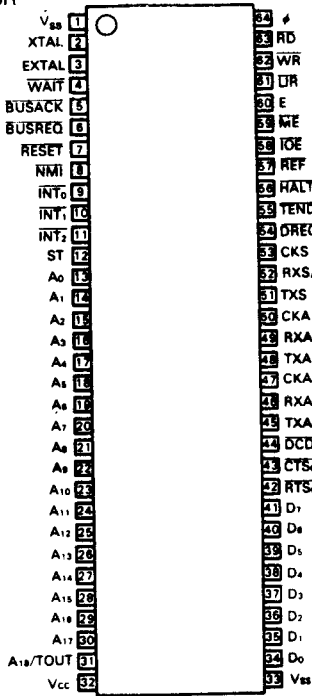

(DP-64S)

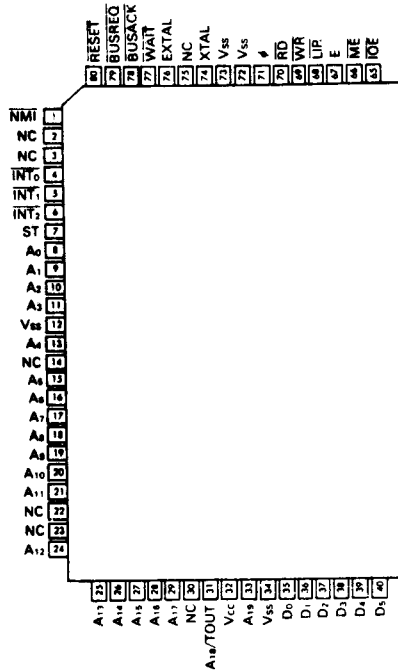

(FP-80B)

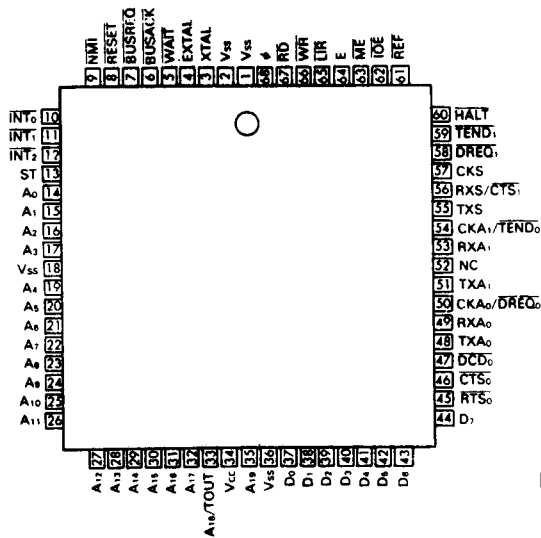

(CP-68)

NC: Not connected.  
Please leave the NC pins open.

# HD64180R/Z

## PIN ASSIGNMENT

• HD64180Z

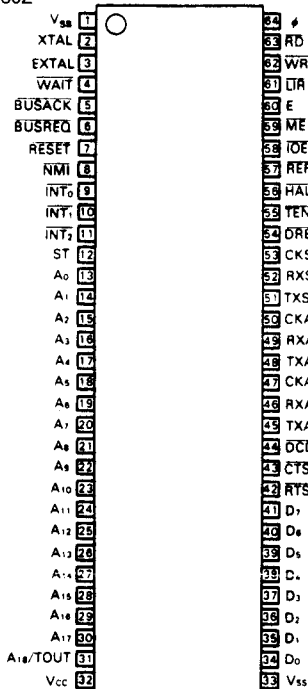

(DP-64S)

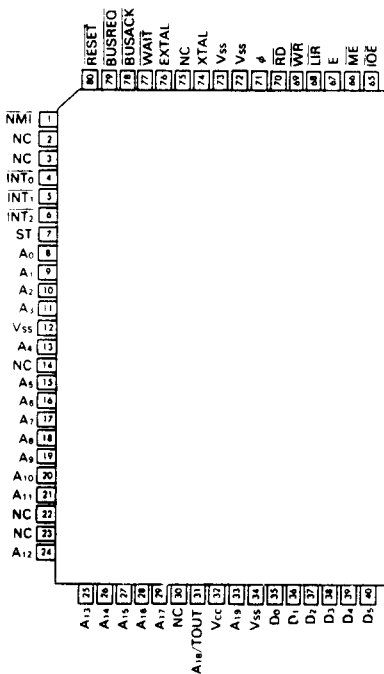

(FP-80B)

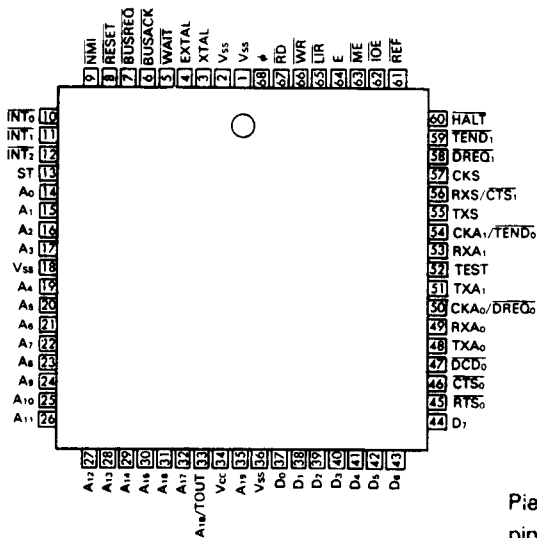

■ HD64180 BLOCK DIAGRAM

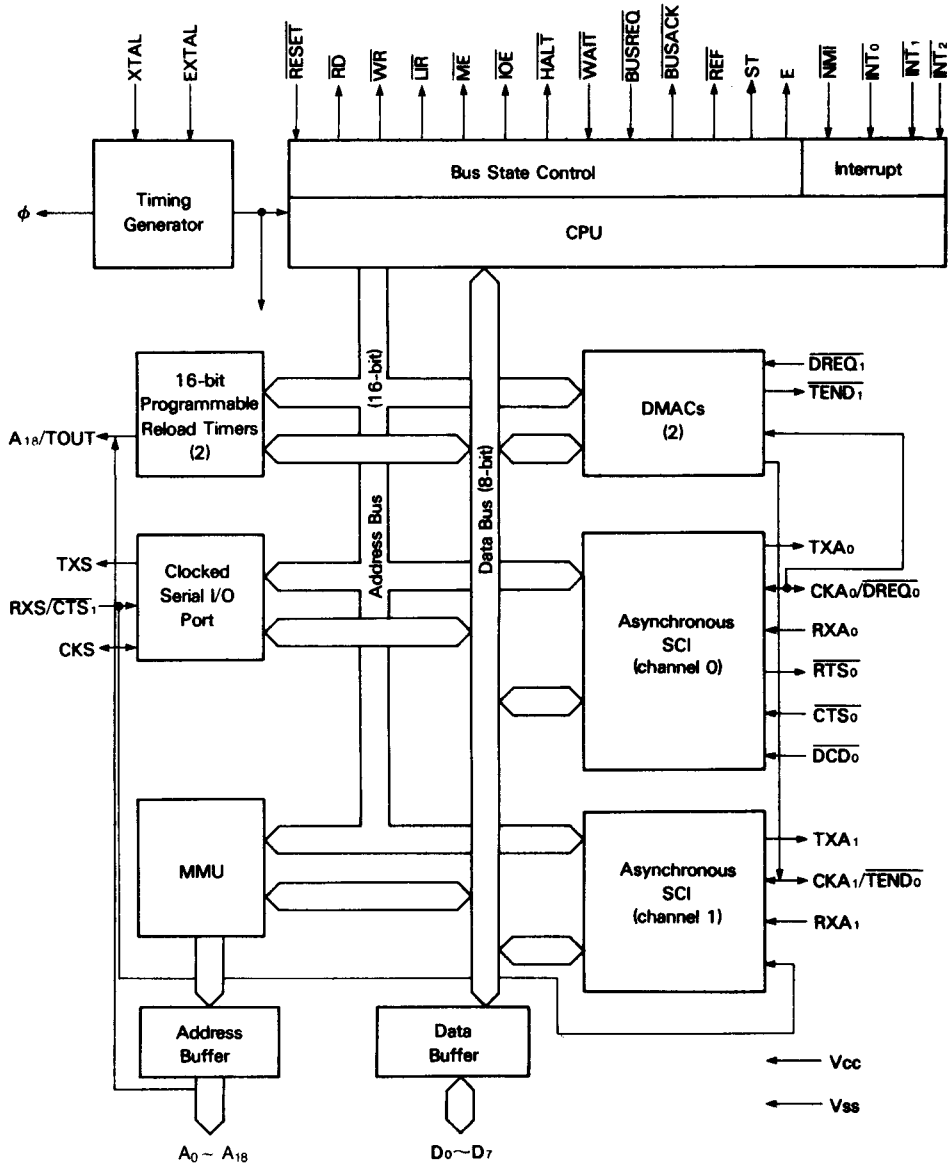

(A<sub>0</sub> ~ A<sub>19</sub>: HD64180R1, HD64180Z; FP-80, CP-68)

# HD64180R/Z

## ■ ABSOLUTE MAXIMUM RATINGS

Item	Symbol	Value	Unit
Supply Voltage	$V_{CC}$	-0.3 ~ +7.0	V
Input Voltage	$V_{in}$	-0.3 ~ $V_{CC} + 0.3$	V
Operating Temperature	$T_{opr}$	$\frac{-20 \sim +75^*}{-40 \sim +85^{**}}$	°C
Storage Temperature	$T_{stg}$	-55 ~ +150	°C

(NOTE) Permanent LSI damage may occur if maximum ratings are exceeded. Normal operation should be under recommended operating conditions. If these conditions are exceeded, it could affect reliability of LSI.

\*Standard Temp.  
\*\*Industrial Temp.

## ■ ELECTRICAL CHARACTERISTICS

- DC CHARACTERISTICS ( $V_{CC} = 5V \pm 10\%$ ,  $V_{SS} = 0V$ ,  $t_a = -20 \sim +75^\circ C$ , Industrial Temp  
 $T_a = -40 \sim +85^\circ C$ , unless otherwise noted.)

Item	Symbol	Condition	min.	typ.	max.	Unit	
Input "H" Voltage RESET, EXTAL, NMI	$V_{IH1}$		$V_{CC} - 0.6$	—	$V_{CC} + 0.3$	V	
Input "H" Voltage Except RESET, EXTAL, NMI	$V_{IH2}$		2.0	—	$V_{CC} + 0.3$	V	
Input "L" Voltage RESET, EXTAL, NMI	$V_{IL1}$		-0.3	—	0.6	V	
Input "L" Voltage Except RESET, EXTAL, NMI	$V_{IL2}$		-0.3	—	0.8	V	
Output "H" Voltage All Outputs	$V_{OH}$	$\frac{I_{OH} = -200\mu A}{I_{OH} = -20\mu A}$	$\frac{2.4}{V_{CC} - 1.2}$	—	—	V	
Output "L" Voltage All Outputs	$V_{OL}$	$I_{OL} = 2.2mA$	—	—	0.45	V	
Input Leakage Current All Inputs Except XTAL, EXTAL	$I_{IL}$	$V_{in} = 0.5 \sim V_{CC} - 0.5$	—	—	1.0	$\mu A$	
Three State Leakage Current	$I_{TL}$	$V_{in} = 0.5 \sim V_{CC} - 0.5$	—	—	1.0	$\mu A$	
Power Dissipation (Normal Operation)	$I_{CC}^*$	$\frac{f = 4MHz}{f = 6MHz}{f = 8MHz}{f = 10MHz}$	—	$\frac{10}{15}{20}{25}$	$\frac{20}{30}{40}{50}$	mA	
Power Dissipation (SYSTEM STOP mode)		$\frac{f = 4MHz}{f = 6MHz}{f = 8MHz}{f = 10MHz}$	—	$\frac{2.5}{3.3}{5.0}{6.3}$	$\frac{5.0}{7.5}{10.0}{12.5}$		
Pin Capacitance	$C_p$	$\frac{V_{in} = 0V, f = 1MHz}{T_a = 25^\circ C}$	—	—	12		pF

\* $V_{IH} \text{ min.} = V_{CC} - 1.0V$ ,  $V_{IL} \text{ max.} = 0.8V$  (all output terminal are at no load)

• DC CHARACTERISTICS ( $V_{CC}=5V \pm 10\%$ ,  $V_{SS}=0V$ ,  $t_a=-20 \sim +75^\circ C$ , Industrial Temp  
 $T_a=-40 \sim +85^\circ C$ , unless otherwise noted.)

Item	Symbol	HD64180R/Z-4		HD64180R/Z-6		HD64180R/Z-8		HD64180R/Z-10		unit
		min.	max.	min.	max.	min.	max.	min.	max.	
Clock Cycle Time	$t_{cyc}$	250	2000	162	2000	125	2000	100	2000	ns
Clock "H" Pulse Width	$t_{CHW}$	110		65		50		40		ns
Clock "L" Pulse Width	$t_{CLW}$	110		65		50		40		ns
Clock Fall Time	$t_{cf}$		15		15		15		10	ns
Clock Rise Time	$t_{cr}$		15		15		15		10	ns
Address Delay Time	$t_{AD}$		110		90		80		70	ns
Address Set-up Time ( $\overline{ME}$ or $\overline{IQE} \downarrow$ )	$t_{AS}$	50		30		20			70	ns
$\overline{ME}$ Delay Time 1	$t_{MED1}$		85		60		45	10		ns
$\overline{RD}$ Delay Time 1	$t_{RDD1}$	$IO C = 1$	85		60		45		50	ns
		$IO C = 0$	85		65		60		55	
$\overline{LIR}$ Delay Time 1	$t_{LD1}$		100		80		70*		60	ns
Address Hold Time 1 ( $\overline{ME}$ , $\overline{IQE}$ , $\overline{RD}$ or $\overline{WR} \uparrow$ )	$t_{AH}$	80		35		20		10		ns
$\overline{ME}$ Delay Time 2	$t_{MED2}$		85		60		45		50	ns
$\overline{RD}$ Delay Time 2	$t_{RDD2}$		85		60		45		50	ns
$\overline{LIR}$ Delay Time 2	$t_{LD2}$		100		80		70*		60	ns
Data Read Set-up Time	$t_{DRS}$	50		40		30		25		ns
Data Read Hold Time	$t_{DRH}$	0		0		0		0		ns
ST Delay Time 1	$t_{STD1}$		110		90		70		60	ns
ST Delay Time 2	$t_{STD2}$		110		90		70		60	ns
$\overline{WAIT}$ Set-up Time	$t_{WS}$	80		40		40		30		ns
$\overline{WAIT}$ Hold Time	$t_{WH}$	70		40		40		30		ns
Write Data Floating Delay Time	$t_{WDZ}$		100		95		70		60	ns
$\overline{WR}$ Delay Time 1	$t_{WRD1}$		90		65		60		50	ns
Write Data Delay Time	$t_{WDD}$		110		90		80		60	ns
Write Data Set-up Time ( $\overline{WR} \downarrow$ )	$t_{WDS}$	60		40		20		15		ns
$\overline{WR}$ Delay Time 2	$t_{WRD2}$		90		80		60		50	ns
$\overline{WR}$ Pulse Width	$t_{WRP}$	280		170		130		110		ns

\*For a loading capacitance of less than or equal to 40 picofarads and operating temperature from 0 to 50 degrees, subtract 10 nanoseconds from the value given in the maximum columns.

# HD64180R/Z

Item	Symbol	HD64180R/Z-4		HD64180R/Z-6		HD64180R/Z-8		HD64180R/Z-10		unit
		min.	max.	min.	max.	min.	max.	min.	max.	
Write Data Hold Time ( $\overline{WR} \uparrow$ )	$t_{WDH}$	60		40		15		10		ns
IOE Delay Time 1	$t_{IOD1}$		85		60		45		50	ns
			85		65		60		55	ns
IOE Delay Time 2	$t_{IOD2}$		85		60		45		50	ns
IOE Delay Time 2 ( $\overline{LIR} \downarrow$ )	$t_{IOD3}$	540		340		250		200		ns
INT Set-up Time ( $\phi \downarrow$ )	$t_{INTS}$	80		40		40		30		ns
INT Hold Time ( $\phi \downarrow$ )	$t_{INTH}$	70		40		40		30		ns
NMI Pulse Width	$t_{NMIW}$	120		120		100		80		ns
BUSREQ Set-up Time ( $\phi \downarrow$ )	$t_{BRS}$	80		40		40		30		ns
BUSREQ Hold Time	$t_{BRH}$	70		40		40		30		ns
BUSACK Delay Time 1	$t_{BAD1}$		100		95		70		60	ns
BUSACK Delay Time 2	$t_{BAD2}$		100		95		70		60	ns
Bus Floating Delay Time	$t_{BZD}$		130		125		90		70	ns
$\overline{ME}$ Pulse Width (HIGH)	$t_{MEWH}$	200		110		90		70		ns
$\overline{ME}$ Pulse Width (LOW)	$t_{MEWL}$	210		125		100		80		ns
$\overline{REF}$ Delay Time 1	$t_{RFD1}$		110		90		80		60	ns
$\overline{REF}$ Delay Time 2	$t_{RFD2}$		110		90		80		60	ns
$\overline{HALT}$ Delay Time 1	$t_{HAD1}$		110		90		80		50	ns
$\overline{HALT}$ Delay Time 2	$t_{HAD2}$		110		90		80		50	ns
$\overline{DREQ}$ i Set-up Time	$t_{DRQS}$	80		40		40		30		ns
$\overline{DREQ}$ i Hold Time	$t_{DRQH}$	70		40		40		30		ns
$\overline{TEND}$ i Delay Time 1	$t_{TED1}$		85		70		60		50	ns
$\overline{TEND}$ i Delay Time 2	$t_{TED2}$		85		70		60		50	ns
Enable Delay Time 1	$t_{ED1}$		100		95		70		60	ns
Enable Delay Time 2	$t_{ED2}$		100		95		70		60	ns
E Pulse Width (HIGH)	$P_{WEH}$	150		75		65		55		ns
E Pulse Width (LOW)	$P_{WEL}$	300		180		130		110		ns



Item	Symbol	HD64180R/Z-4		HD64180R/Z-6		HD64180R/Z-8		HD64180R/Z-10		unit
		min.	max.	min.	max.	min.	max.	min.	max.	
Enable Rise Time	$t_{Er}$		25		20		20		20	ns
Enable Fall Time	$t_{Ef}$		25		20		20		20	ns
Timer Output Delay Time	$t_{TOD}$		300		300		200		150	ns
CSI/O Transmit Data Delay Time (Internal Clock Operation)	$t_{STDI}$		200		200		200		150	ns
CSI/O Transmit Data Delay Time (External Clock Operation)	$t_{STDE}$		7.5tcyc + 300		7.5tcyc + 300		7.5tcyc + 200		7.5tcyc + 150	ns
CSI/O Receive Data Set-up Time (Internal Clock Operation)	$t_{SRSI}$	1		1		1		1		tcyc
CSI/O Receive Data Hold Time (Internal Clock Operation)	$t_{SRHI}$	1		1		1		1		tcyc
CSI/O Receive Data Set-up Time (External Clock Operation)	$t_{SRSE}$	1		1		1		1		tcyc
CSI/O Receive Data Hold Time (External Clock Operation)	$t_{SRHE}$	1		1		1		1		tcyc
RESET Set-up Time	$t_{RES}$	120		120		100		80		ns
RESET Hold Time	$t_{REH}$	80		80		70		60		ns
Oscillator Stabilization Time	$t_{OSC}$		20		20		20		40	ms
External Clock Rise Time (EXTAL)	$t_{EXr}$		25		25		25		25	ns
External Clock Fall Time (EXTAL)	$t_{EXf}$		25		25		25		25	ns
RESET Rise Time	$t_{Rr}$		50		50		50		50	ms
RESET Fall Time	$t_{Rf}$		50		50		50		50	ms
Input Rise Time (except EXTAL, RESET)	$t_{Ir}$		10		100		100		100	ns
Input Fall Time (except EXTAL, RESET)	$t_{If}$		100		100		100		100	ns

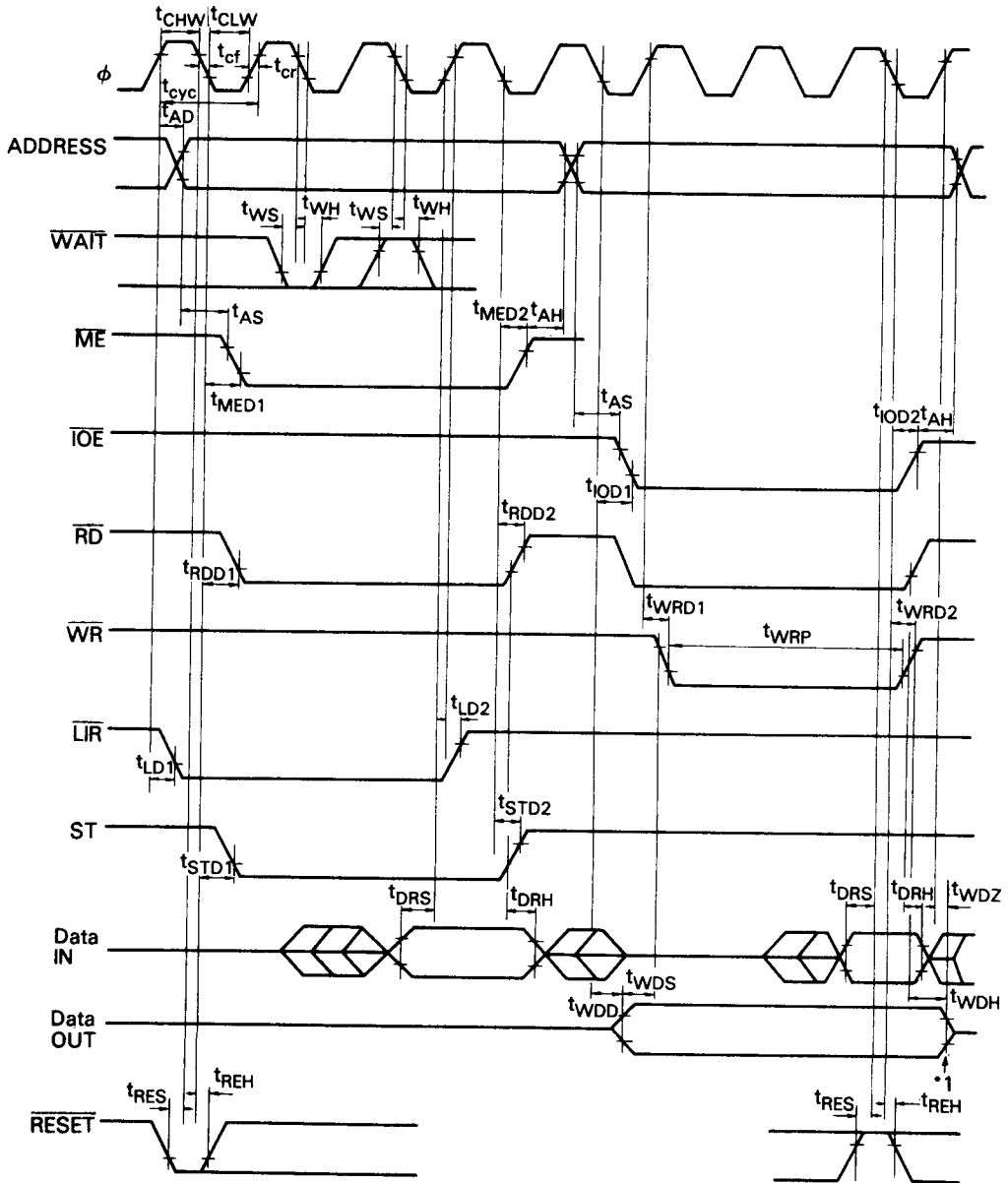

\*1 Output buffer is off at this point.

Figure 1 CPU Timing (1)

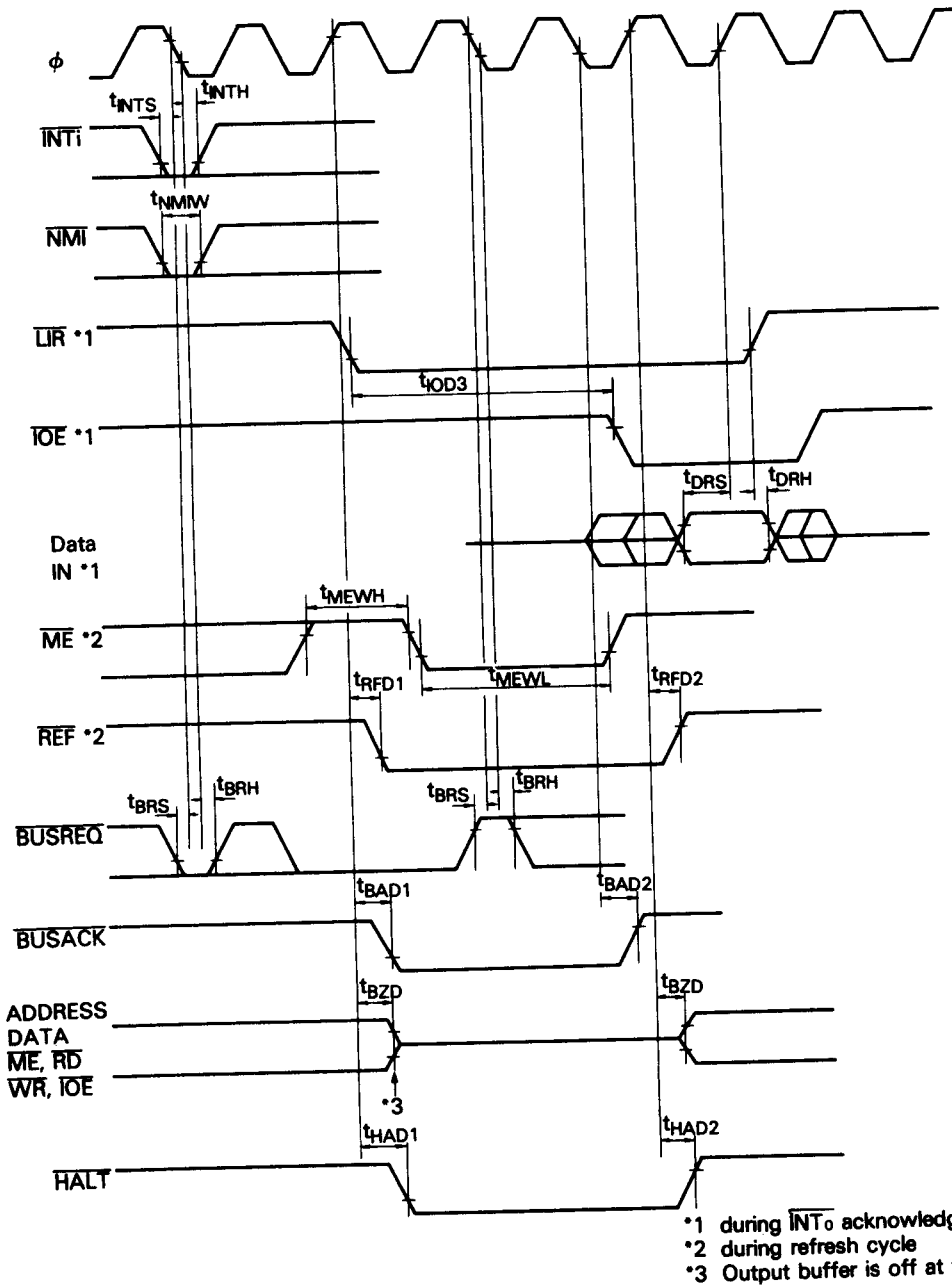

Figure 1 CPU Timing (2)

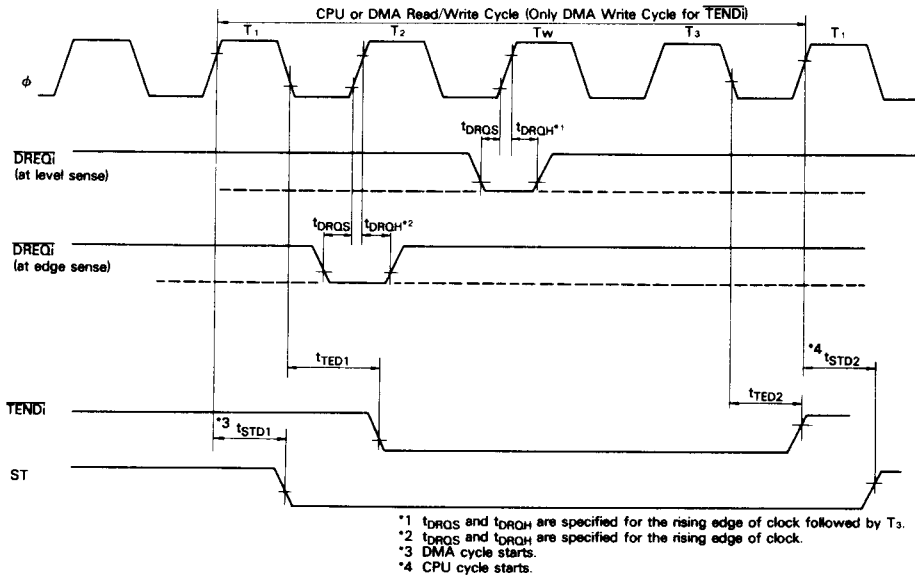

Figure 2 DMA Control Signals

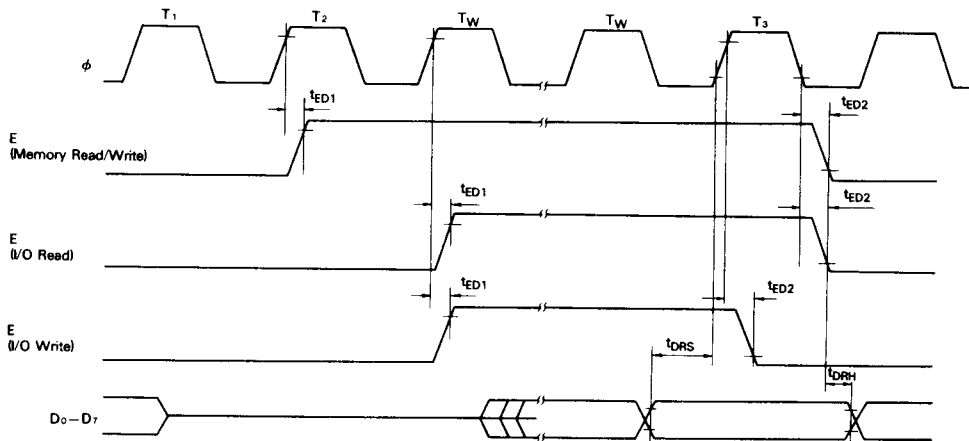

Figure 3 E Clock Timing (1)

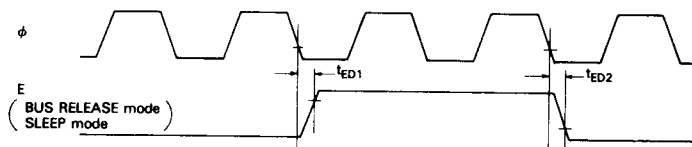

Figure 3 E Clock Timing (2)

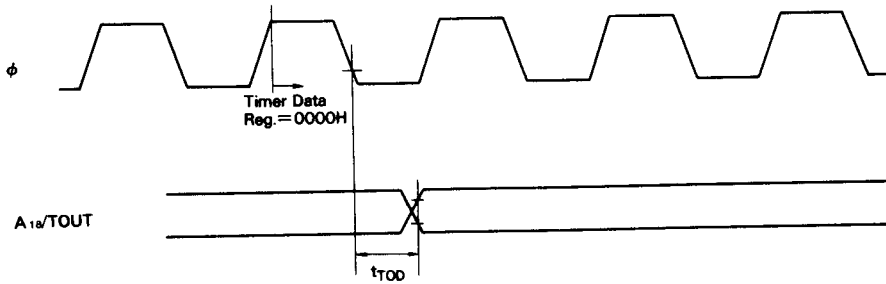

Figure 4 Timer Output Timing

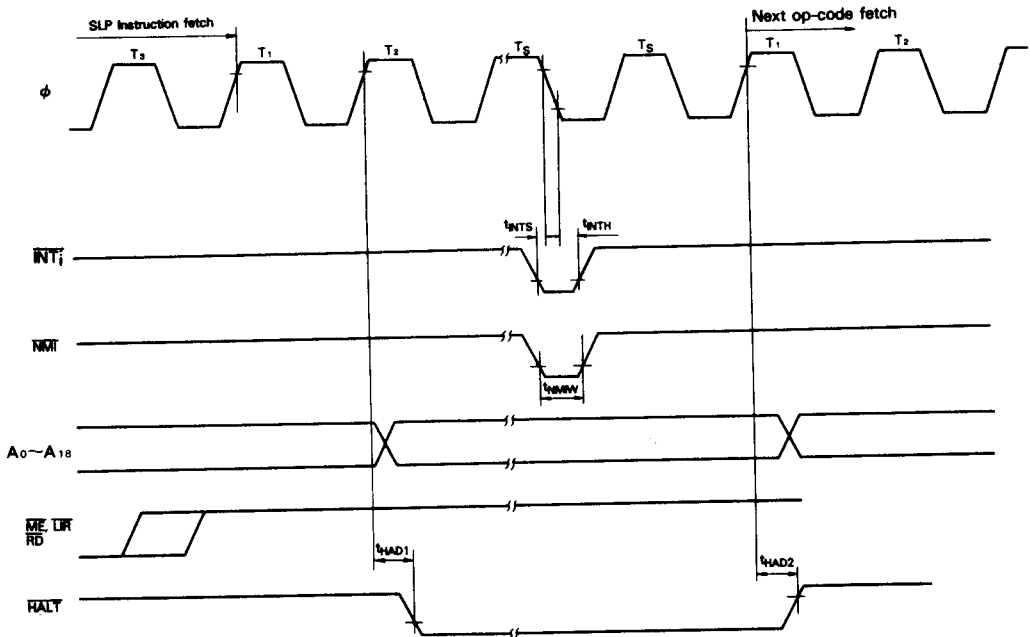

Figure 5 SLP Execution Cycle

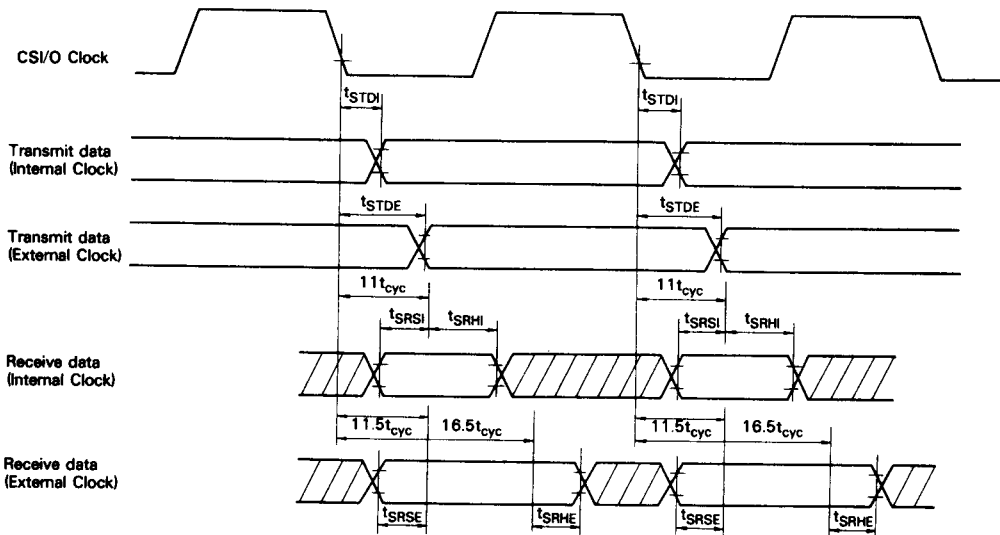
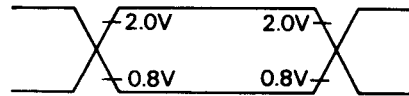
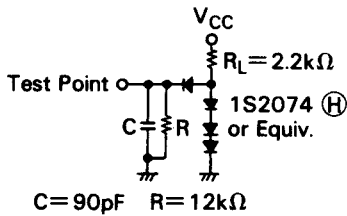
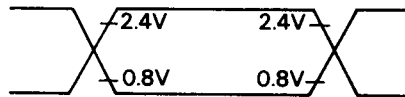

Figure 6 CSI/O Receive/Transmit Timing



Reference Level (Input)



Reference Level (Output)

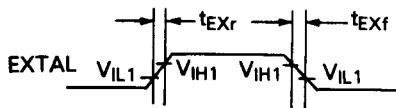

EXTAL Rise time and Fall time

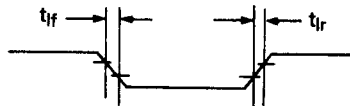

Inputs, other than EXTERNAL, Rise time and Fall time

Figure 7 Bus Timing Test Load (TTL Load)

**1 PIN DESCRIPTION**

**XTAL (IN)**

Crystal oscillator connection. Should be left open if an external TTL clock is used. It is noted this input is not a TTL level input. See Table D.C. characteristics.

**EXTAL (IN)**

Crystal oscillator connection. An external TTL clock can be input on this line. This input is schmitt triggered.

**φ (OUT)**

System Clock. The frequency is equal to one-half of crystal oscillator.

**RESET — CPU Reset (IN)**

When LOW, initializes the HD64180 CPU. All output signals are held inactive during RESET.

**A<sub>0</sub>-A<sub>17</sub> — Address Bus (OUT, 3-STATE)**

**A<sub>18</sub>/TOUT**

19-bit address bus provides physical memory addresses of up to 512k bytes. The address bus enters the high impedance state during RESET and when another device acquires the bus as indicated by BUSREQ and BUSACK LOW. A<sub>18</sub> is multiplexed with the TOUT output from PRT channel 1. During RESET, the address bus function is selected. TOUT function can be selected under software control.

**D<sub>0</sub>-D<sub>7</sub> — Data Bus (IN/OUT, 3-STATE)**

Bidirectional 8-bit data bus. The data bus enters the high impedance state during RESET and when another device acquires the bus as indicated by BUSREQ and BUSACK LOW.

**RD — Read (OUT, 3-STATE)**

Used during a CPU read cycle to enable transfer from the external memory or I/O device to the CPU data bus.

**WR — Write (OUT, 3-STATE)**

Used during a CPU write cycle to enable transfer from the CPU data bus to the external memory or I/O device.

**ME — Memory Enable (OUT, 3-STATE)**

Indicates memory read or write operation. The HD64180 asserts ME LOW in the following cases.

- (a) When fetching instructions and operands.
- (b) When reading or writing memory data.
- (c) During memory access cycles of DMA.
- (d) During dynamic RAM refresh cycles.

**IOE — I/O Enable (OUT, 3-STATE)**

Indicates I/O read or write operation. The HD64180 asserts IOE LOW in the following cases.

- (a) When reading or writing I/O data.
- (b) During I/O access cycles of DMA.
- (c) During INT<sub>0</sub> acknowledge cycle

**WAIT — Bus Cycle Wait (IN)**

Introduces wait states to extend memory and I/O cycles. If LOW at the falling edge of T<sub>2</sub>, a wait state (T<sub>w</sub>) is inserted. Wait states will continue to be inserted until the WAIT input is sampled HIGH at the falling edge of T<sub>w</sub>, at which time the bus cycle will proceed to completion.

**E — Enable (OUT)**

Synchronous clock for connection to HD63 × × series and other 6800/6500 series compatible peripheral LSIs.

**BUSREQ — Bus Request (IN)**

Another device may request use of the bus by asserting BUSREQ LOW. The CPU will stop executing instructions and

places the address bus, data bus, RD, WR, ME and IOE in the high impedance state.

**BUSACK — Bus Acknowledge (OUT)**

When the CPU completes bus release (in response to BUSREQ LOW), it will assert BUSACK LOW. This acknowledges that the bus is free for use by the requesting device.

**HALT — Halt/Sleep Status (OUT)**

Asserted LOW after execution of the HALT or SLP instructions. Used with LIR and ST output pins to encode CPU status.

**LIR — Load Instruction Register (OUT)**

Asserted LOW when the current cycle is an op-code fetch cycle. Used with HALT and ST output pins to encode CPU status.

**ST — Status (OUT)**

Used with the HALT and LIR output pins to encode CPU status.

Table 1 Status Summary

ST	HALT	LIR	Operation
0	1	0	CPU operation (1st op-code fetch)
1	1	0	CPU operation (2nd op-code and 3rd op-code fetch)
1	1	1	CPU operation (MC except for op-code fetch)
0	X	1	DMA operation
0	0	0	HALT mode
1	0	1	SLEEP mode (including SYSTEM STOP mode)

NOTE) X: Don't care  
MC: Machine cycle

**REF — Refresh (OUT)**

When LOW, indicates the CPU is in the dynamic RAM refresh cycle and the low-order 8 bits (A<sub>6</sub>-A<sub>7</sub>) of the address bus contain the refresh address.

**NMI — Non-Maskable Interrupt (IN)**

When edge transition from HIGH to LOW is detected, forces the CPU to save certain state information and vector to an interrupt service routine at address 0066H. The saved state information is restored by executing the RETN (Return from Non-Maskable Interrupt) instruction.

**INT<sub>0</sub> — Maskable Interrupt Level 0 (IN)**

When LOW, requests a CPU interrupt (unless masked) and saves certain state information unless masked by software. INT<sub>0</sub> requests service using one of three software programmable interrupt modes.

Mode	Operation
0	Instruction fetched and executed from data bus.
1	Instruction fetched and executed from address 003BH.
2	Vector System — Low-order 8 bits vector table address fetched from data bus.

In all modes, the saved state information is restored by executing RETI (Return from Interrupt) instruction.



## HD64180R/Z

### $\overline{INT}_1, \overline{INT}_2$ – Maskable Interrupt Level 1, 2 (IN)

When LOW, requests a CPU interrupt (unless masked) and saves certain state information unless masked by software.  $\overline{INT}_1$  and  $\overline{INT}_2$  (and internally generated interrupts) request interrupt service using a vector system similar to Mode 2 of  $\overline{INT}_0$ .

### $\overline{DREQ}_0$ – DMA Request – Channel 0 (IN)

When LOW (programmable edge or level sensitive), requests DMA transfer service from channel 0 of the HD64180 DMAC.  $\overline{DREQ}_0$  is used for Channel 0 memory  $\longleftrightarrow$  I/O and memory  $\longleftrightarrow$  memory mapped I/O transfers.  $\overline{DREQ}_0$  is not used for memory  $\longleftrightarrow$  memory transfers. This pin is multiplexed with  $\overline{CKA}_0$ .

### $\overline{TEND}_0$ – Transfer End – Channel 0 (OUT)

Asserted LOW synchronous with the last write cycle of channel 0 DMA transfer to indicate DMA completion to an external device. This pin is multiplexed with  $\overline{CKA}_1$ .

### $\overline{DREQ}_1$ – DMA Request – Channel 1 (IN)

When LOW (programmable edge or level sense), requests DMA transfer service from channel 1 of the HD64180 DMAC. Channel 1 supports Memory  $\longleftrightarrow$  I/O transfers.

### $\overline{TEND}_1$ – Transfer End – Channel 1 (OUT)

Asserted LOW synchronous with the last write cycle of channel 1 DMA transfer to indicate DMA completion to an external device.

### $\overline{TXA}_0$ – Asynchronous Transmit Data – Channel 0 (OUT)

Asynchronous transmit data from channel 0 of the Asynchronous Serial Communication Interface (ASCI).

### $\overline{RXA}_0$ – Asynchronous Receive Data – Channel 0 (IN)

Asynchronous receive data to channel 0 of the ASCI.

### $\overline{CKA}_0$ – Asynchronous Clock – Channel 0 (IN/OUT)

Clock input/output for channel 0 of the ASCI. This pin is multiplexed (software selectable) with  $\overline{DREQ}_0$ .

### $\overline{RTS}_0$ – Request to Send – Channel 0 (OUT)

Programmable modem control output signal for channel 0 of the ASCI.

### $\overline{CTS}_0$ – Clear to Send – Channel 0 (IN)

Modem control input signal for channel 0 of the ASCI.

### $\overline{DCD}_0$ – Data Carrier Detect – Channel 0 (IN)

Modem control input signal for channel 0 of the ASCI.

### $\overline{TXA}_1$ – Asynchronous Transmit Data – Channel 1 (OUT)

Asynchronous transmit data from channel 1 of the ASCI.

### $\overline{RXA}_1$ – Asynchronous Receive Data – Channel 1 (IN)

Asynchronous receive data to channel 1 of the ASCI.

### $\overline{CKA}_1$ – Asynchronous Clock – Channel 1 (IN/OUT)

Clock input/output for channel 1 of the ASCI. This pin is multiplexed (software selectable) with  $\overline{TEND}_0$ .

### $\overline{CTS}_1$ – Clear to Send – Channel 1 (IN)

Modem control input signal for channel 1 of the ASCI. This pin is multiplexed (software selectable) with RXS.

### $\overline{TXS}$ – Clocked Serial Transmit Data (OUT)

Clocked serial transmit data from the Clocked Serial I/O Port (CSI/O).

### $\overline{RXS}$ – Clocked Serial Receive Data (IN)

Clocked serial receive data to the CSI/O. This pin is multiplexed (software selectable) with ASCI channel 1  $\overline{CTS}_1$  modem control input.

### $\overline{CKS}$ – Serial Clock (IN/OUT)

Input or output clock for the CSI/O.

### $\overline{TOUT}$ – Timer Output (OUT)

Pulse output from Programmable Reload Timer channel 1. This pin is multiplexed (software selectable) with  $A_{18}$  (Address 18).

### $V_{CC}$ – Power Supply

### $V_{SS}$ – Ground

### Multiplexed pin descriptions

#### $A_{18}/\overline{TOUT}$

During RESET, this pin is initialized as  $A_{18}$  pin. If either TOCl or TOC0 bit in Timer Control Register (TCR) is set to 1,  $\overline{TOUT}$  function is selected.

If TOCl and TOC0 bits are cleared to 0,  $A_{18}$  function is selected.

#### $\overline{CKA}_0/\overline{DREQ}_0$

During RESET, this pin is initialized as  $\overline{CKA}_0$  pin. If either DM1 or SM1 in DMA Mode Register (DMODE) is set to 1,  $\overline{DREQ}_0$  function is always selected.

#### $\overline{CKA}_1/\overline{TEND}_0$

During RESET, this pin is initialized as  $\overline{CKA}_1$  pin. If  $\overline{CKA1D}$  bit in ASCI control register ch 1 (CNTLA1) is set to 1,  $\overline{TEND}_0$  function is selected. If  $\overline{CKA1D}$  bit is set to 0,  $\overline{CKA}_1$  function is selected.

#### $\overline{RXS}/\overline{CTS}_1$

During RESET, this pin is initialized as  $\overline{RXS}$  pin. If CTS1E bit in ASCI status register ch1 (STAT1) is set to 1,  $\overline{CTS}_1$  function is selected.

If CTS1E bit is set to 0,  $\overline{RXS}$  function is selected.



**2 CPU REGISTERS**

The HD64180 CPU registers consist of Register Set GR, Register Set GR' and Special Registers.

The Register Set GR consists of 8-bit Accumulator (A), 8-bit Flag Register (F), and three General Purpose Registers (BC, DE, and HL) which may be treated as 16-bit registers (BC, DE, and HL) or as individual 8-bit registers (B, C, D, E, H, and L) depending on the instruction to be executed. The Register Set GR' is alternate register set of Register Set GR and also contains Accumulator

(A'), Flag Register (F') and three General Purpose Registers (BC', DE', and HL'). While the alternate Register Set GR' contents are not directly accessible, the contents can be programmably exchanged at high speed with those of Register Set GR.

The Special Registers consist of 8-bit Interrupt Vector Register (I), 8-bit R Counter (R), two 16-bit Index Registers (IX and IY), 16-bit Stack Pointer (SP), and 16-bit Program Counter (PC).

Fig. 8 shows CPU registers configuration.

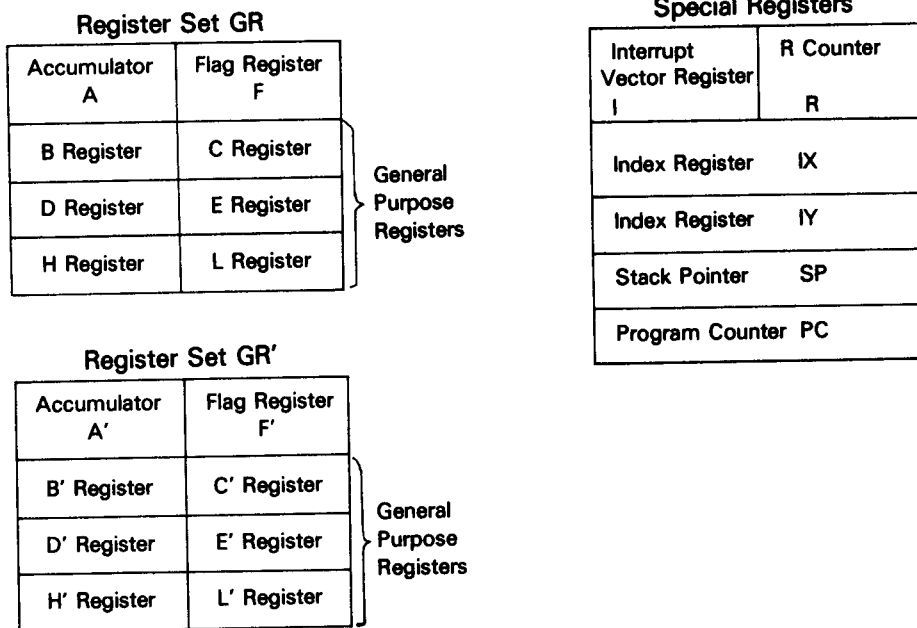

Figure 8 CPU Register Configuration

**2.1 Register Description**

**(1) Accumulator (A, A')**

The Accumulator (A) serves as the primary register used for many arithmetic, logical and I/O instructions.

**(2) Flag Registers (F, F')**

The flag register stores various status bits (described in the next section) which reflect the results of instruction execution.

**(3) General Purpose Registers (BC, BC', DE, DE', HL, HL')**

The General Purpose Registers are used for both address and data operation. Depending on instruction, each half (8 bits) of these registers (B, C, D, E, H, and L) may also be used.

**(4) Interrupt Vector Register (I)**

For interrupts which require a vector table address to be calculated (INT<sub>0</sub> Mode 2, INT<sub>1</sub>, INT<sub>2</sub> and internal interrupts), the Interrupt Vector Register (I) provides the most significant byte of the vector table address.

**(5) R Counter (R)**

The least significant seven bits of the R Counter (R) serve to count the number of instructions executed by the HD64180. R is

incremented for each CPU op-code fetch cycles (each LIR cycles).

**(6) Index Registers (IX, and IY)**

The Index Registers are used for both address and data operations. For addressing, the contents of a displacement specified in the instruction are added to or subtracted from the Index Register to determine an effective operand address.

**(7) Stack Pointer (SP)**

The Stack Pointer (SP) contains the memory address based LIFO stack.

**(8) Program Counter (PC)**

The Program Counter (PC) contains the address of the instruction to be executed and is automatically updated after each instruction fetch.

**(9) Flag Register (F)**

The Flag Register stores the logical state reflecting the results of instruction execution. The contents of the Flag Register are used to control program flow and instruction operation.

# HD64180R/Z

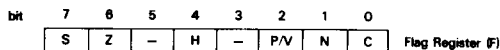

### S: Sign (bit 7)

S stores the state of the most significant bit (bit 7) of the result. This is useful for operations with signed numbers in which values with bit 7 = 1 are interpreted as negative.

### Z: Zero (bit 6)

Z is set to 1 when instruction execution results containing 0. Otherwise, Z is reset to 0.

### H: Half Carry (bit 4)

H is used by the DAA (Decimal Adjust Accumulator) instruction to reflect borrow or carry from the least significant 4 bits and thereby adjust the results of BCD addition and subtraction.

### P/V: Parity/Overflow (bit 2)

P/V serves a dual purpose. For logical operations P/V is set to 1 if the number of 1 bit in the result is even and P/V is reset to 0 if the number of 1 bit in the result is odd. For two complement arithmetic, P/V is set to 1 if the operation produces a result which is outside the allowable range (+127 to -128 for 8-bit operations, +32767 to -32768 for 16-bit operations).

### N: Negative (bit 1)

N is set to 1 if the last arithmetic instruction was a subtract operation (SUB, DEC, CP, etc.) and N is reset to 0 if the last arithmetic

instruction was an addition operation (ADD, INC, etc.).

### C: Carry (bit 0)

C is set to 1 when a carry (addition) or borrow (subtraction) from the most significant bit of the result occurs. C is also affected by Accumulator logic operations such as shifts and rotates.

## 3 ADDRESSING MODES

The HD64180 instruction set includes eight addressing modes.

- Implied Register
- Register Direct
- Register Indirect
- Indexed
- Extended
- Immediate
- Relative
- IO

### (1) Implied Register (IMP)

Certain op-codes automatically imply register usage, such as the arithmetic operations which inherently reference the Accumulator, Index Registers, Stack Pointer and General Purpose Registers.

### (2) Register Direct (REG)

Many op-codes contain bit fields specifying registers to be used for the operation. The exact bit field definition vary depending on instruction as follows.

## 8-bit Register

g or g' field	Register
0 0 0	B
0 0 1	C
0 1 0	D
0 1 1	E
1 0 0	H
1 0 1	L
1 1 0	-
1 1 1	A

ww field	Register
0 0	BC
0 1	DE
1 0	HL
1 1	SP

xx field	Register
0 0	BC
0 1	DE
1 0	IX
1 1	SP

## 16-bit Register

zz field	Register
0 0	BC
0 1	DE
1 0	HL
1 1	AF

yy field	Register
0 0	BC
0 1	DE
1 0	IY
1 1	SP

Suffixed H and L to ww,xx,yy,zz (ex. wwH,IXL) indicate upper and lower 8-bit of the 16-bit register respectively.

**(3) Register Indirect (REG)**

The memory operand address is contained in one of the 16-bit General Purpose Registers (BC, DE and HL).



**(6) Immediate (IMMED)**

The memory operands are contained within one or two bytes of the instruction.

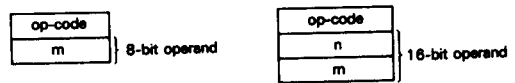

**(4) Indexed (INDX)**

The memory operand address is calculated using the contents of an Index Register (IX or IY) and an 8-bit signed displacement specified in the instruction.

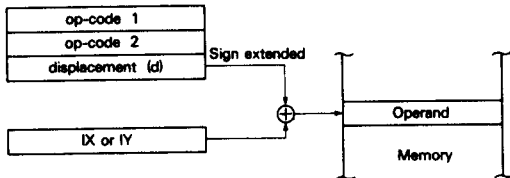

**(7) Relative (REL)**

Relative addressing mode is only used by the conditional and unconditional branch instructions. The branch displacement (relative to the contents of the program counter) is contained in the instruction.

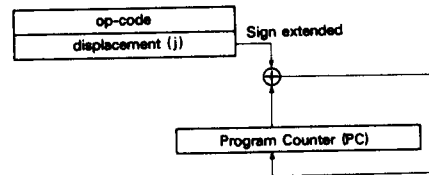

**(5) Extended (EXT)**

The memory operand address is specified by two bytes contained in the instruction.

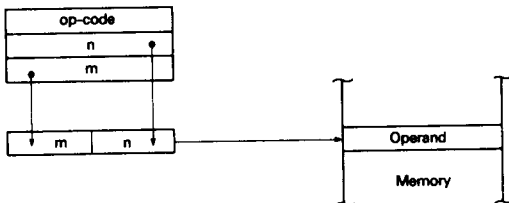

**(8) IO (IO)**

IO addressing mode is used only by I/O instructions. This mode specifies I/O address ( $\overline{IOE} = 0$ ) and outputs them as follows.

- (1) An operand is output to  $A_0-A_7$ . The Contents of Accumulator is output to  $A_8-A_{15}$ .
- (2) The Contents of Register B is output to  $A_0-A_7$ . The Contents of Register C is output to  $A_8-A_{15}$ .
- (3) An operand is output to  $A_0-A_7$ . 00H is output to  $A_8-A_{15}$ . (useful for internal I/O register access)
- (4) The Contents of Register C is output to  $A_0-A_7$ . 00H is output to  $A_8-A_{15}$ . (useful for internal I/O register access)

# HD64180R/Z

## ■ CPU BUS TIMING

This section explains the HD64180 CPU timing for the following operations.

- (1) Instruction (op-code) fetch timing.
- (2) Operand and data read/write timing.
- (3) I/O read/write timing.
- (4) Basic instruction (fetch and execute) timing.
- (5) RESET timing.
- (6) BUSREQ/BUSACK bus exchange timing.

The basic CPU operation consists of one or more "machine cycles" (MC). A machine cycle consists of three system clocks,  $T_1$ ,  $T_2$  and  $T_3$  while accessing memory or I/O, or it consists of one system clock,  $T_1$  while the CPU internal operation. The system clock ( $\phi$ ) is half frequency of crystal oscillation (Ex. 8 MHz crystal  $\rightarrow \phi$  of 4

MHz, 250 nsec). For interfacing to slow memory or peripherals, optional wait states ( $T_w$ ) may be inserted between  $T_2$  and  $T_3$ .

### • Instruction (op-code) Fetch Timing

Fig. 9 shows the instruction (op-code) fetch timing with no wait states.

An op-code fetch cycle is externally indicated when the  $\overline{\text{LIR}}$  (Load Instruction Register) output pin is LOW.

In the first half of  $T_1$ , the address bus ( $A_0-A_{18}$ ) is driven with the contents of the Program Counter (PC). Note that this is the translated address output of the HD64180 on-chip MMU.

In the second half of  $T_1$ , the  $\overline{\text{ME}}$  (Memory Enable) and  $\overline{\text{RD}}$  (Read) signals are asserted LOW, enabling the memory.

The op-code on the data bus is latched at the rising edge of  $T_3$  and the bus cycle terminates at the end of  $T_3$ .

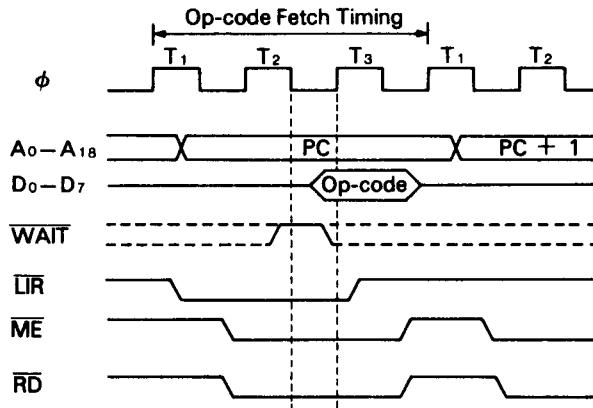

Figure 9 Op-Code Fetch Timing

Fig. 10 illustrates the insertion of wait states ( $T_w$ ) into the op-code fetch cycle. Wait states ( $T_w$ ) are controlled by the external  $\overline{\text{WAIT}}$  input combined with an on-chip programmable wait state generator.

At the falling edge of  $T_2$  the combined  $\overline{\text{WAIT}}$  input is sampled. If

$\overline{\text{WAIT}}$  input is asserted LOW, a wait state ( $T_w$ ) is inserted. The address bus,  $\overline{\text{ME}}$ ,  $\overline{\text{RD}}$  and  $\overline{\text{LIR}}$  are held stable during wait states. When the  $\overline{\text{WAIT}}$  is sampled inactive HIGH at the falling edge of  $T_w$ , the bus cycle enters  $T_3$  and completes at the end of  $T_3$ .

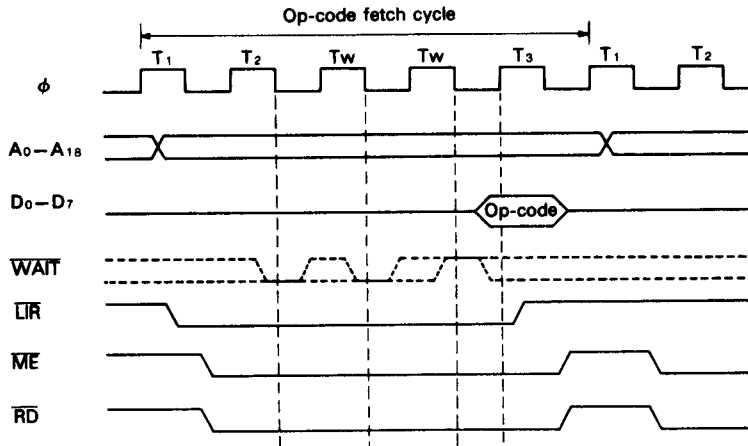

Figure 10 Op-Code Fetch Timing (with wait state)

• **Operand and Data Read/Write Timing**

The instruction operand and data read/write timing differs from op-code fetch timing in two ways. First, the LIR output is held inactive. Second, the read cycle timing is relaxed by one-half clock cycle since data is latched at the falling edge of  $T_3$ .

Instruction operands include immediate data, displacement and extended addresses and have the same timing as memory data reads.

During memory write cycles the  $\overline{ME}$  signal goes active in the

second half of  $T_1$ . At the end of  $T_1$ , the data bus is driven with the write data.

At the start of  $T_2$ , the  $\overline{WR}$  signal is asserted LOW enabling the memory.  $\overline{ME}$  and  $\overline{WR}$  go inactive in the second half of  $T_3$  followed by deactivation of the write data on the data bus.

Wait states ( $T_w$ ) are inserted as previously described for op-code fetch cycles.

Fig. 11 illustrates the read/write timing without wait states ( $T_w$ ), while Fig. 12 illustrates read/write timing with wait states ( $T_w$ ).

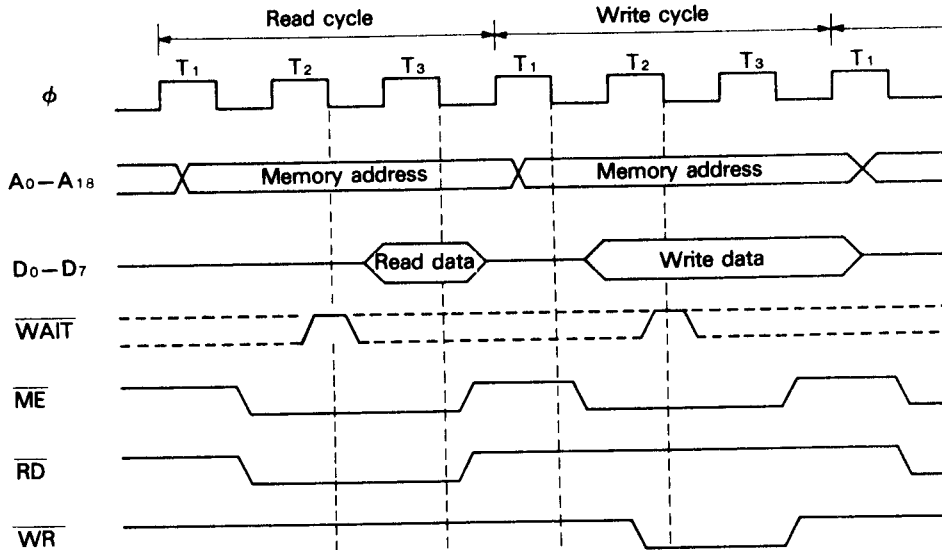

Figure 11 Memory Read/Write Timing (without wait state)

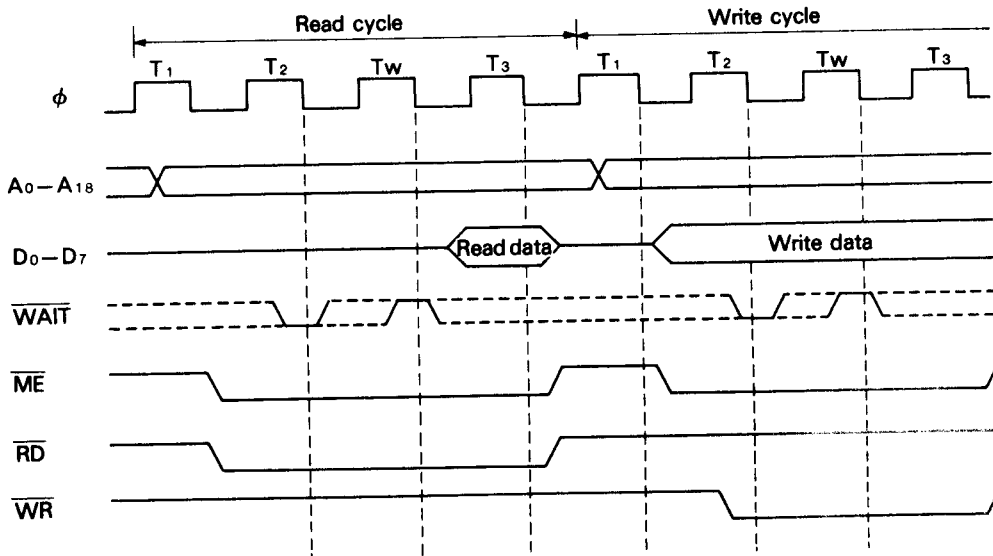

Figure 12 Memory Read/Write Timing (with wait state)

# HD64180R/Z

## 4.3 I/O Read/Write Timing

I/O instructions cause data read/write transfer which differs from memory data transfer in the following three ways. The IOE (I/O Enable) signal is asserted LOW instead of the ME signal. The 16-bit I/O address is not translated by the MMU and  $A_{16}-A_{18}$  are held

LOW. At least one wait state ( $T_w$ ) is always inserted for I/O read and write cycles (except internal I/O cycles).

Fig. 13 shows I/O read/write timing with the automatically inserted wait state ( $T_w$ ).

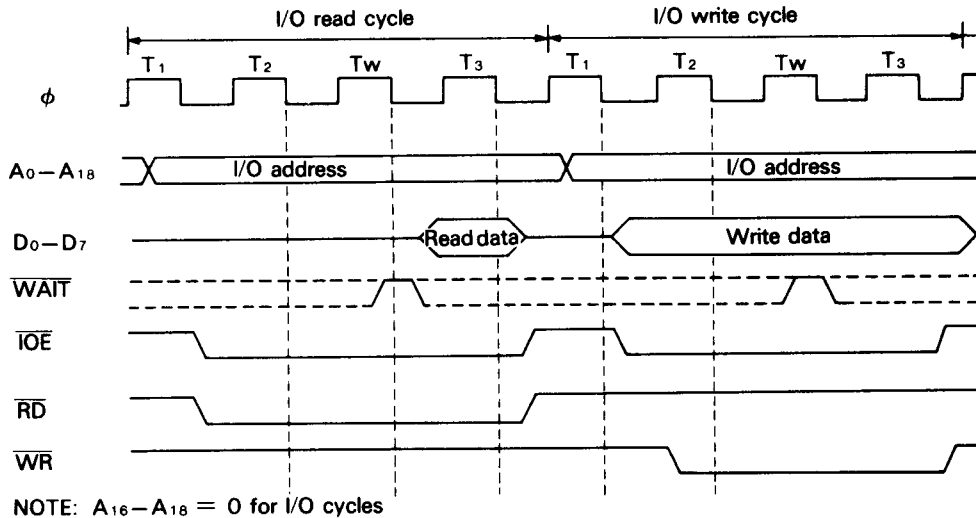

Figure 13 I/O Read/Write Timing

## 4.4 Basic Instruction Timing

An instruction may consist of a number of machine cycles including op-code fetch, operand fetch and data read/write cycles. An instruction may also include cycles for internal processing in which case the bus is idle.

The example in Fig. 14 illustrates the bus timing for the data transfer instruction LD (IX+d).g. This instruction moves the contents of a CPU register (g) to the memory location with address

computed by adding a signed 8-bit displacement (d) to the contents of an index register (IX).

The instruction cycle starts with the two machine cycles to read the two bytes instruction op-code as indicated by  $\overline{LIR}$  LOW. Next, the instruction operand (d) is fetched.

The external bus is idle while the CPU computes the effective address. Finally, the computed memory location is written with the contents of the CPU register (g).

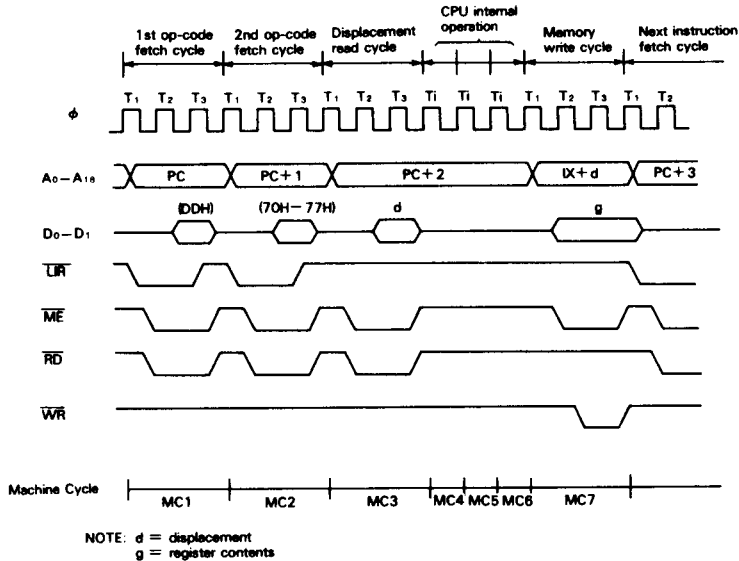

Figure 14 LD (IX+d), g Instruction Timing

**4.5 RESET Timing**

Fig. 15 shows the HD64180 hardware RESET timing. If the RESET pin is LOW for at least six clock cycles, processing is terminated and the HD64180 restarts execution from (logical and physical) address 00000H.

ated and the HD64180 restarts execution from (logical and physical) address 00000H.

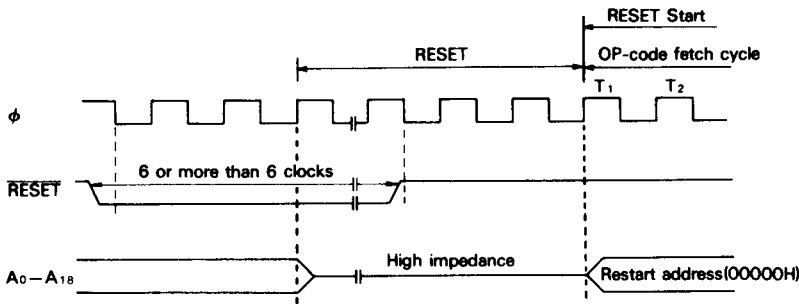

Figure 15 RESET Timing

**4.6 BUSREQ/BUSACK Bus Exchange Timing**

The HD64180 can coordinate the exchange of control, address and data bus ownership with another bus master. The alternate bus master can request the bus release by asserting the BUSREQ (Bus Request) input LOW. After the HD64180 releases the bus, it relinquishes control to the alternate bus master by asserting the BUSACK (Bus Acknowledge) output LOW.

The bus may be released by the HD64180 at the end of each machine cycle. In this context a machine cycle consists of a minimum of 3 clock cycles (more if wait states are inserted) for op-code fetch, memory read/write and I/O read/write cycles. Except for these cases, a machine cycle corresponds to one clock cycle.

When the bus is released, the address ( $A_0-A_{16}$ ), data ( $D_0-D_7$ )

and control ( $\overline{ME}$ ,  $\overline{IOE}$ ,  $\overline{RD}$ , and  $\overline{WR}$ ) signals are placed in the high impedance state.

Note that dynamic RAM refresh is not performed when the HD64180 has released the bus. The alternate bus master must provide dynamic memory refreshing if the bus is released for long periods of time.

Fig. 16 illustrates BUSREQ/BUSACK bus exchange during a memory read cycle. Fig. 17 illustrates bus exchange when the bus release is requested during an HD64180 CPU internal operation. BUSREQ is sampled at the falling edge of the system clock prior to  $T_3$ ,  $T_1$  and  $T_x$  (BUS RELEASE state). If BUSREQ is asserted LOW at the falling edge of the clock state prior to  $T_x$ , another  $T_x$  is executed.

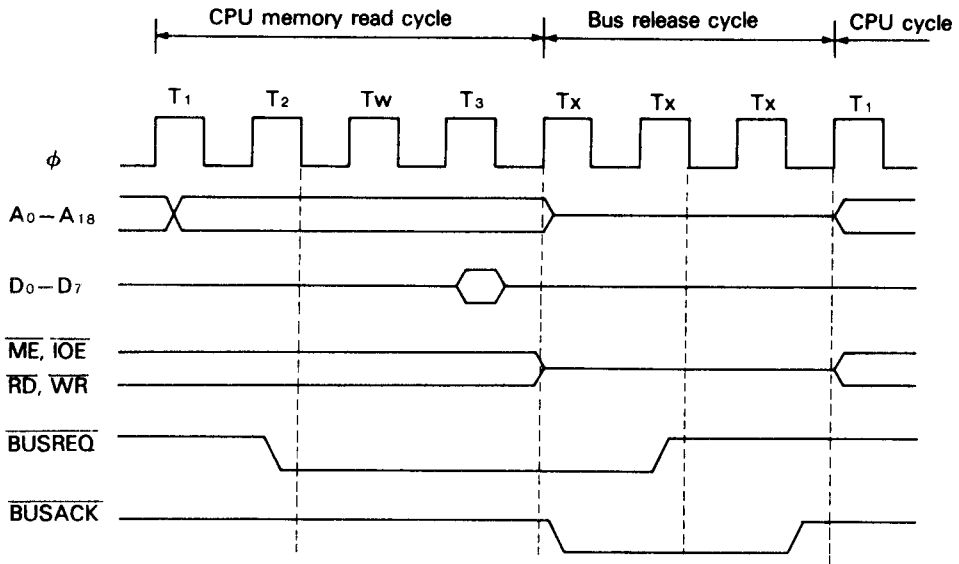

Figure 16 Bus Exchange Timing (1)

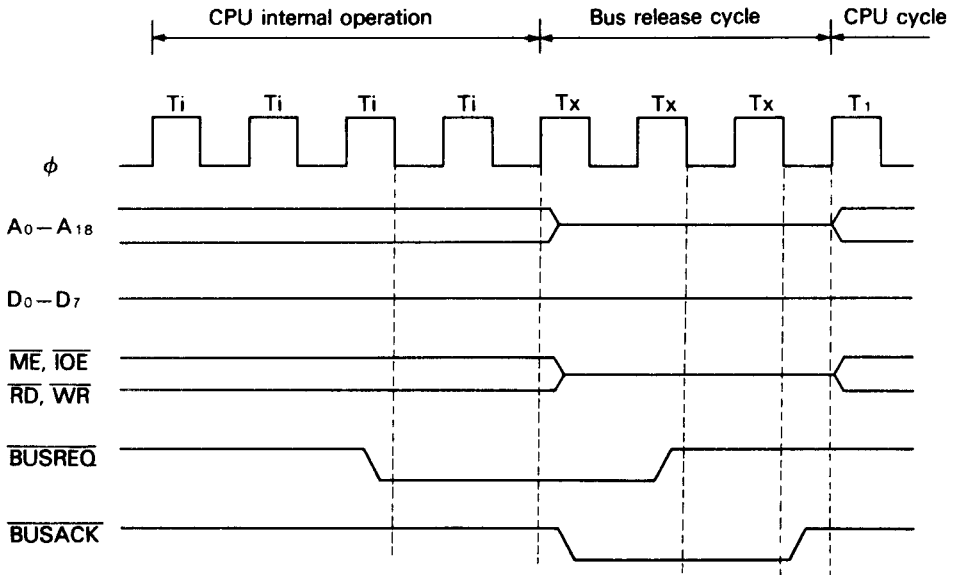

Figure 17 Bus Exchange Timing (2)



**5 HALT AND LOW POWER OPERATION MODES**

The HD64180 can operate in 4 different modes. HALT mode, IOSTOP mode and two low power operation modes – SLEEP and SYSTEM STGP. Note that in all operating modes, the basic CPU clock (XTAL, EXTAL) must remain active.

**5.1 HALT Mode**

HALT mode is entered by execution of the HALT instruction (op-code = 76H) and has the following characteristics.

- (1) The internal CPU clock remains active.
- (2) All internal and external interrupts can be received.
- (3) Bus exchange (BUSREQ and BUSACK) can occur.
- (4) Dynamic RAM refresh cycle (REF) insertion continues at the programmed interval.
- (5) I/O operations (ASCI, CSI/O and PRT) continue.
- (6) The DMAC can operate.
- (7) The HALT output pin is asserted LOW.
- (8) The external bus activity consists of repeated 'dummy' fetches of the op-code following the HALT instruction.

Essentially, the HD64180 operates normally in HALT mode, except that instruction execution is stopped.

HALT mode can be exited in the following two ways.

**RESET Exit from HALT Mode**

If the RESET input is asserted LOW for at least six clock cycles, HALT mode is exited and the normal RESET sequence (restart at address 00000H) is initiated.

**Interrupt Exit from HALT Mode**

When an internal or external interrupt is generated, HALT mode is exited and the normal interrupt response sequence is initiated.

If the interrupt source is masked (individually by enable bit, or globally by IEF<sub>1</sub> state), the HD64180 remains in HALT mode. However, NMI interrupt will initiate the normal NMI interrupt response sequence independent of the state of IEF<sub>1</sub>.

HALT timing is shown in Fig. 18.

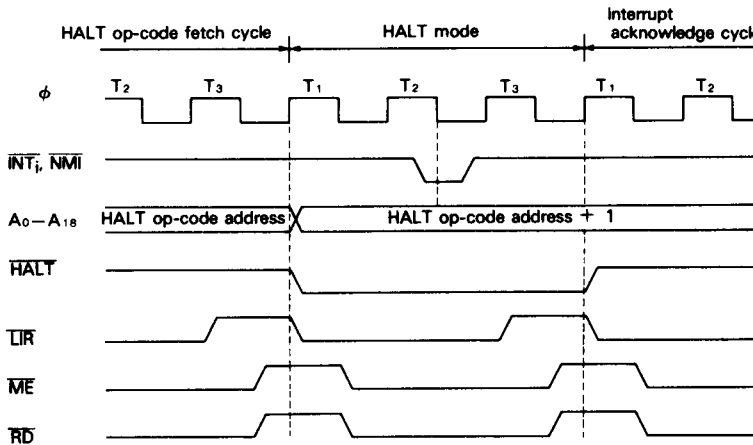

Figure 18 HALT Timing

**5.2 SLEEP Mode**

SLEEP mode is entered by execution of the 2 byte SLP instruction. SLEEP mode has the following characteristics.

- (1) The internal CPU clock stops, reducing power consumption.
- (2) The internal crystal oscillator does not stop.
- (3) Internal and external interrupt inputs can be received.
- (4) DRAM refresh cycles stop.
- (5) I/O operations using on-chip peripherals continue.
- (6) The internal DMAC stop.
- (7) BUSREQ can be received and acknowledged.
- (8) Address outputs go HIGH and all other control signal output become inactive HIGH.
- (9) Data Bus, 3-state.

SLEEP mode is exited in one of two ways as shown below.

**RESET Exit from SLEEP Mode**

If the RESET input is held LOW for at least six clock cycles, the HD64180 will exit SLEEP mode and begin the normal RESET sequence with execution starting at address (logical and physical) 00000H.

**Interrupt Exit from SLEEP Mode**

The SLEEP mode is exited by detection of an external (NMI, INT<sub>0</sub>, INT<sub>1</sub>, INT<sub>2</sub>) or internal (ASCI, CSI/O, PRT) interrupt.

In the case of NMI, SLEEP Mode is exited and the CPU begins the normal NMI interrupt response sequence.

In the case of all other interrupts, the interrupt response depends on the state of the global interrupt enable flag (IEF<sub>1</sub>) and the individual interrupt source enable bit.

If the individual interrupt condition is disabled by the corresponding enable bit, occurrence of that interrupt is ignored and the CPU remains in the SLEEP state.

Assuming the individual interrupt condition is enabled, the response to that interrupt depends on the global interrupt enable flag (IEF<sub>1</sub>). If interrupts are globally enabled (IEF<sub>1</sub>=1) and an individually enabled interrupt occurs, SLEEP mode is exited and the appropriate normal interrupt response sequence is executed.

If interrupts are globally disabled (IEF<sub>1</sub>=0) and an individually enabled interrupt occurs, SLEEP mode is exited and instruction execution begins with the instruction following the SLP instruction. Note that this provides a technique for synchronization with high speed external events without incurring the latency imposed by an interrupt response sequence.

Fig. 19 shows SLEEP timing.

**5.3 IOSTOP Mode**

IOSTOP mode is entered by setting the IOSTP bit of the I/O Control Register (ICR) to 1. In this case, on-chip I/O (ASCI, CSI/O, PRT) stops operating. However, the CPU continues to operate. Recovery from IOSTOP mode is by clearing the IOSTP bit in ICR to 0.

**5.4 SYSTEM STOP Mode**

SYSTEM STOP mode is the combination of SLEEP and IOSTOP modes. SYSTEM STOP mode is entered by setting the IOSTP bit in ICR to 1 followed by execution of the SLP instruction. In this mode, on-chip I/O and CPU stop operating, reducing power consumption. Recovery from SYSTEM STOP mode is the same as recovery from SLEEP mode, noting that internal I/O sources (disabled by IOSTOP) cannot generate a recovery interrupt.

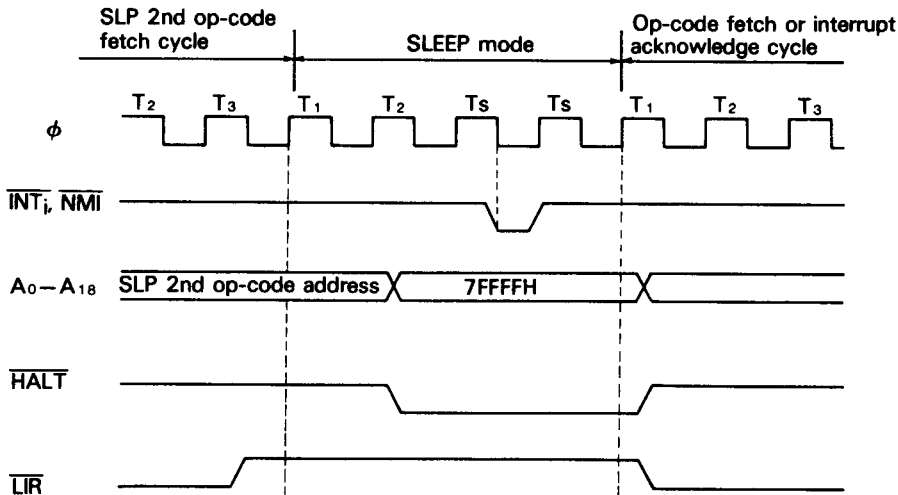

Figure 19 SLEEP Timing

**6 INTERRUPTS**

The HD64180 CPU has twelve interrupt sources, four external and eight internal, with fixed priority.

This section explains the CPU registers associated with interrupt

processing, the TRAP interrupt, interrupt response modes and the external interrupts. The detailed discussion of internal interrupt generation (except TRAP) is presented in the appropriate hardware section (i.e. PRT, DMAC, ASCI and CSI/O).

Priority	Interrupt	
Higher	1	TRAP (Undefined Op-code Trap) . . . . . Internal Interrupt
Priority	2	NMI (Non Maskable Interrupt)
	3	INT <sub>0</sub> (Maskable Interrupt Level 0)
	4	INT <sub>1</sub> (Maskable Interrupt Level 1)
	5	INT <sub>2</sub> (Maskable Interrupt Level 2)
	6	Timer 0
Lower	7	Timer 1
	8	DMA channel 0
	9	DMA channel 1
	10	Clocked Serial I/O Port
	11	Asynchronous SCI channel 0
	12	Asynchronous SCI channel 1

Figure 20 Interrupt Sources

**6.1 Interrupt Control Registers and Flags**

The HD64180 contains three registers and two flags which are associated with interrupt processing.

Register and Flag Name	Function	Access Method
I	Contains upper 8-bit of interrupt vector	LD A, I and LD I, A instructions
IL	Contains lower 8-bit of interrupt vector	I/O instruction (addr = 33H)
ITC	Interrupt/Trap control	I/O instruction (addr = 34H)
IEF <sub>1</sub> , IEF <sub>2</sub>	Enable/disable interrupt	EI, DI, LD A, I, and LD A, R instructions

**(1) Interrupt Vector Register (I)**

Mode 2 for INT<sub>0</sub> external interrupt, INT<sub>1</sub> and INT<sub>2</sub> external interrupts and all internal interrupts (except TRAP) use a programmable vectored technique to determine the address at which interrupt processing starts. In response to the interrupt a 16-bit address is generated. This address accesses a vector table in memory to obtain the address at which execution restarts.

While the method for generation of the least significant byte of the table address differs, all vectored interrupts use the contents of I as the most significant byte of the table address. By programming the contents of I, vector tables can be relocated on 256 bytes boundaries throughout the 64k bytes logical address space.

Note that I is read/written with the LD A, I and LD I, A instructions rather than I/O (IN, OUT) instructions.

I is initialized to 00H during RESET.

**(2) Interrupt Vector Low Register (IL)**

Interrupt Vector Low Register (IL : I/O Address = 33H)

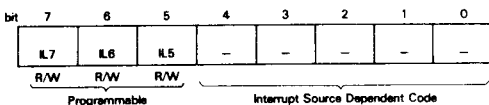

This register determines the most significant three bits of the low-order byte of the interrupt vector table address for external interrupts INT<sub>1</sub> and INT<sub>2</sub> and all internal interrupts (except TRAP). The five least significant bits are fixed for each specific interrupt source. By programming IL the vector table can be relocated on 32 bytes boundaries.

IL is initialized to 00H during RESET.

**(3) INT/TRAP Control Register (ITC)**

INT/TRAP Control Register (ITC : I/O Address = 34H)

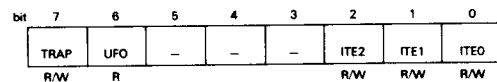

ITC is used to handle TRAP interrupts and to enable or disable the external maskable interrupt inputs INT<sub>0</sub>, INT<sub>1</sub>, and INT<sub>2</sub>.

**TRAP (bit 7)**

This bit is set to 1 when an undefined op-code is fetched. TRAP can be reset under program control by writing it with 0, however it cannot be written with 1 under program control. TRAP is cleared to 0 during RESET.

**UFO: Undefined Fetch Object (bit 6)**

When a TRAP interrupt occurs (TRAP bit is set to 1), the contents of UFO allow determination of the starting address of the undefined instruction. This is necessary since the TRAP may occur on either the second or third byte of the op-code. UFO allows the stacked PC value (stacked in response to TRAP) to be correctly adjusted. If UFO = 0, the first op-code should be interpreted as the stacked PC-1. If UFO = 1, the first op-code address is stacked PC-2. UFO is read-only.

**ITE2, 1, 0: Interrupt Enable 2, 1, 0 (bits 2-0)**

ITE2, ITE1 and ITE0 enable and disable the external interrupt inputs INT<sub>2</sub>, INT<sub>1</sub>, and INT<sub>0</sub> respectively. If cleared to 0, the interrupt is masked. During RESET, ITE0 is initialized to 1 while ITE1 and ITE2 are initialized to 0.

**Interrupt Enable Flag 1, 2 (IEF<sub>1</sub>, IEF<sub>2</sub>)**

IEF<sub>1</sub> controls the overall enabling and disabling of all internal and external maskable interrupts (i.e. all interrupts except NMI and



## HD64180R/Z

TRAP).

If  $IEF_1 = 0$ , all maskable interrupts are disabled.  $IEF_1$  can be reset to 0 by the DI (Disable Interrupts) instruction and set to 1 by the EI (Enable Interrupts) instruction.

The purpose of  $IEF_2$  is to correctly manage the occurrence of NMI. During NMI, the prior interrupt reception state is saved and all maskable interrupts are automatically disabled ( $IEF_1$  copied to

$IEF_2$  and then  $IEF_1$  cleared to 0). At the end of the NMI interrupt service routine, execution of the RETN (Return from Non-maskable Interrupt) will automatically restore the interrupt receiving state (by copying  $IEF_2$  to  $IEF_1$ ) prior to the occurrence of NMI.

$IEF_2$  state can be reflected in the P/V bit of the CPU Status register by executing LD A, I or LD A, R instructions.

Table 2 shows the state of  $IEF_1$  and  $IEF_2$ .

Table 2 State of  $IEF_1$  and  $IEF_2$

CPU Operation	$IEF_1$	$IEF_2$	REMARKS
RESET	0	0	Inhibits the interrupt except NMI and TRAP.
NMI	0	$IEF_1$	Copies the contents of $IEF_1$ to $IEF_2$ .
RETN	$IEF_2$	not affected	Returns from the NMI service routine.
Interrupt except NMI and TRAP	0	0	Inhibits the interrupt except NMI and TRAP.
RETI	not affected	not affected	
TRAP	not affected	not affected	
EI	1	1	
DI	0	0	
LD A, I	not affected	not affected	Transfers the contents of $IEF_2$ to P/V flag.
LD A, R	not affected	not affected	Transfers the contents of $IEF_2$ to P/V flag.

### 6.2 TRAP Interrupt

The HD64180 generates a non-maskable (not affected by the state of  $IEF_1$ ) TRAP interrupt when an undefined op-code fetch occurs. This feature can be used to increase software reliability, implement an 'extended' instruction set, or both. TRAP may occur during op-code fetch cycles and also if an undefined op-code is fetched during the interrupt acknowledge cycle for  $\overline{INT}_0$  when Mode 0 is used.

When a TRAP interrupt occurs the HD64180 operates as follows.

- (1) The TRAP bit in the Interrupt TRAP/Control (ITC) register is set to 1.
- (2) The current PC (Program Counter) value, reflecting the location of the undefined op-code, is saved on the stack.
- (3) The HD64180 vectors to logical address 0. Note that if logical

address 0000H is mapped to physical address 00000H, the vector is the same as for RESET. In this case, testing the TRAP bit in ITC will reveal whether the restart at physical address 00000H was caused by RESET or TRAP.

The state of the UFO (Undefined Fetch Object) bit in ITC allows TRAP manipulation software to correctly 'adjust' the stacked PC depending on whether the second or third byte of the op-code generated the TRAP. If  $UFO = 0$ , the starting address of the invalid instruction is equal to the stacked PC-1. If  $UFO = 1$ , the starting address of the invalid instruction is equal to the stacked PC-2. Fig. 21 shows TRAP Timing.

Note that Bus Release cycle, Refresh cycle, DMA cycle and WAIT cycle can't be inserted just after  $T_{TP}$  state which is inserted for TRAP interrupt sequence.

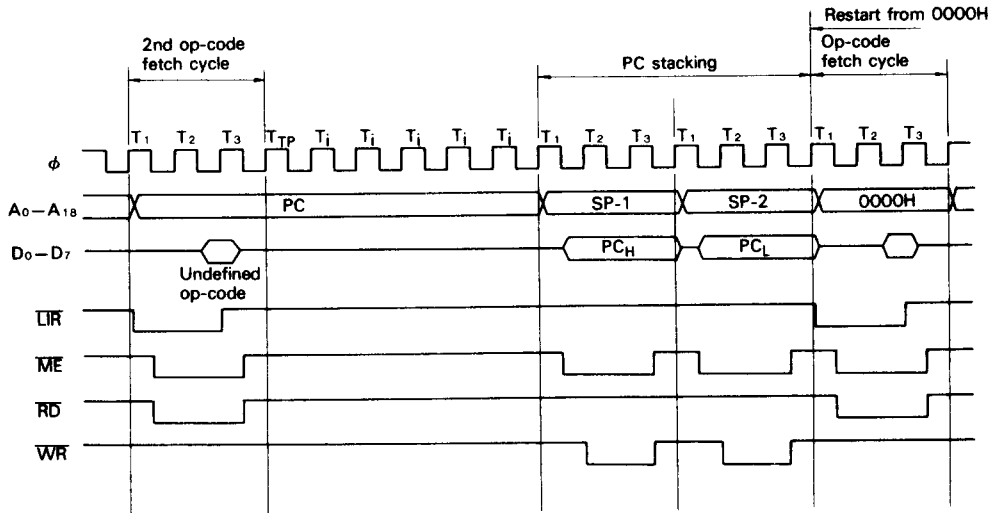

Figure 21 (a) TRAP Timing – 2nd Op-code Undefined

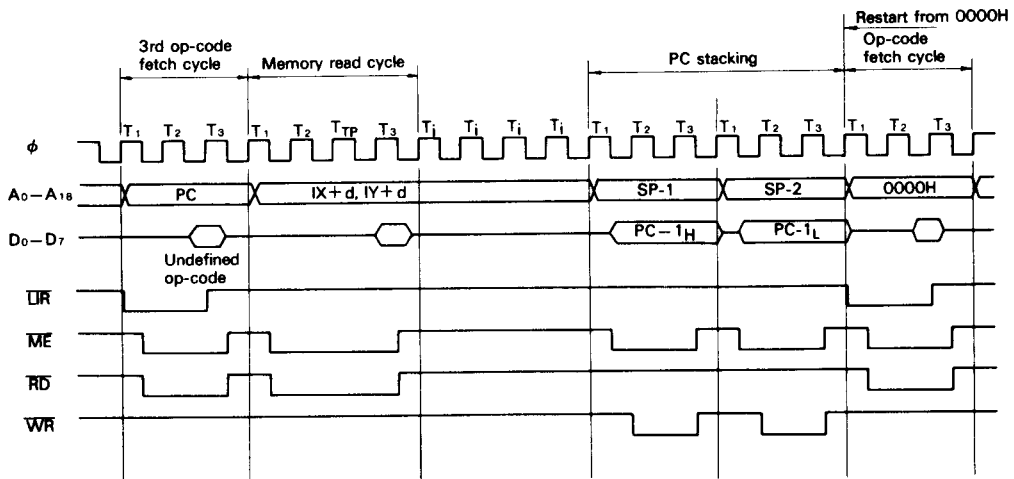

Figure 21 (b) TRAP Timing – 2nd Op-code Undefined

# HD64180R/Z

## 6.3 External Interrupts

The HD64180 has four external hardware interrupt inputs.

- (1)  $\overline{\text{NMI}}$  – Non-maskable Interrupt
- (2)  $\overline{\text{INT}}_0$  – Maskable Interrupt Level 0
- (3)  $\overline{\text{INT}}_1$  – Maskable Interrupt Level 1
- (4)  $\overline{\text{INT}}_2$  – Maskable Interrupt Level 2

$\overline{\text{NMI}}$ ,  $\overline{\text{INT}}_1$  and  $\overline{\text{INT}}_2$  have fixed interrupt response modes.  $\overline{\text{INT}}_0$  has three different software programmable interrupt response modes – Mode 0, Mode 1 and Mode 2.

## 6.4 $\overline{\text{NMI}}$ – Non-Maskable Interrupt

The  $\overline{\text{NMI}}$  interrupt input is edge sensitive and cannot be masked by software. When  $\overline{\text{NMI}}$  is detected, the HD64180 operates as follows.

- (1) DMAC operation is suspended by clearing the DME (DMA Main Enable) bit in DCNTL.
- (2) The PC is pushed onto the stack.
- (3) The contents of  $\text{IEF}_1$  are copied to  $\text{IEF}_2$ . This saves the interrupt reception state that existed prior to  $\overline{\text{NMI}}$ .
- (4)  $\text{IEF}_1$  is cleared to 0. This disables all external and internal maskable interrupts (i.e. all interrupts except  $\overline{\text{NMI}}$  and TRAP).

- (5) Execution commences at logical address 0066H.

The last instruction of an  $\overline{\text{NMI}}$  service routine should be RETN (Return from Non-maskable Interrupt). This restores the stacked PC, allowing the interrupted program to continue. Furthermore, RETN causes  $\text{IEF}_2$  to be copied to  $\text{IEF}_1$ , restoring the interrupt reception state that existed prior to the  $\overline{\text{NMI}}$ .

Note that  $\overline{\text{NMI}}$ , since it can be accepted during HD64180 on-chip DMAC operation, can be used to externally interrupt DMA transfer. The  $\overline{\text{NMI}}$  service routine can reactivate or abort the DMAC operation as required by the application.

For  $\overline{\text{NMI}}$ , special care must be taken to insure that interrupt inputs do not 'overrun' the  $\overline{\text{NMI}}$  service routine. Unlimited  $\overline{\text{NMI}}$  inputs without a corresponding number of RETN instructions will eventually cause stack overflow.

Fig. 22 shows the use of  $\overline{\text{NMI}}$  and RETN while Fig. 23 details  $\overline{\text{NMI}}$  response timing.  $\overline{\text{NMI}}$  is edge sensitive and the internally latched  $\overline{\text{NMI}}$  falling edge is held until it is sampled. If the falling edge of  $\overline{\text{NMI}}$  is latched before the falling edge of clock state prior to  $T_3$  or  $T_i$  in the last machine cycle, the internally latched  $\overline{\text{NMI}}$  is sampled at the falling edge of the clock state prior to  $T_3$  or  $T_i$  in the last machine cycle and  $\overline{\text{NMI}}$  acknowledge cycle begins at the end of the current machine cycle.

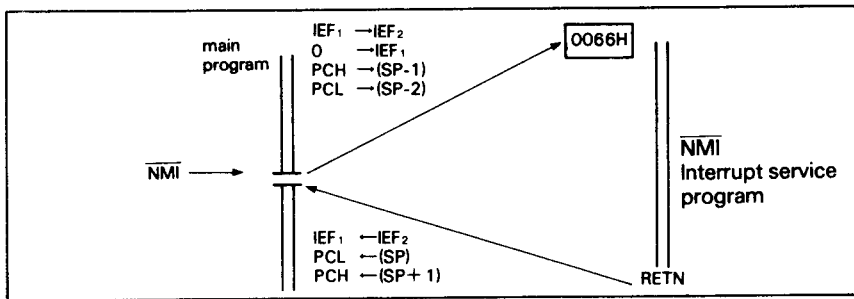

Figure 22  $\overline{\text{NMI}}$  Sequence

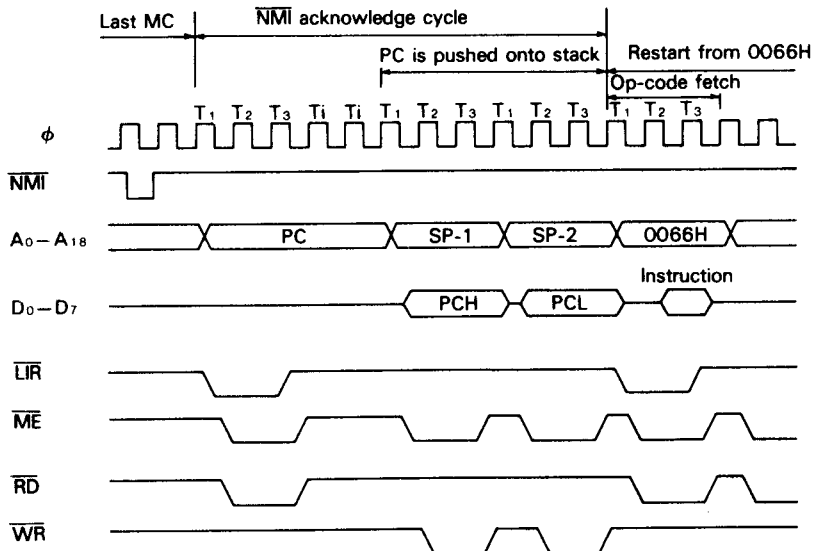

Figure 23  $\overline{\text{NMI}}$  Timing

**6.5  $\overline{INT}_0$  – Maskable Interrupt Level 0**

The next highest priority external interrupt after  $\overline{NMI}$  is  $\overline{INT}_0$ .  $\overline{INT}_0$  is sampled at the falling edge of the clock state prior to  $T_3$  or  $T_i$  in the last machine cycle. If  $\overline{INT}_0$  is asserted LOW at the falling edge of the clock state prior to  $T_3$  or  $T_i$  in the last machine cycle,  $\overline{INT}_0$  is accepted. The interrupt is masked if either the IEF<sub>0</sub> flag or the ITE0 (Interrupt Enable 0) bit in ITC are cleared to 0. Note that after RESET the state is as follows.

- (1) IEF<sub>0</sub> is 0, so  $\overline{INT}_0$  is masked.
- (2) ITE0 is 1, so  $\overline{INT}_0$  is enabled by execution of the EI (Enable Interrupts) instruction.

The  $\overline{INT}_0$  interrupt is unique in that three programmable interrupt response modes are available – Mode 0, Mode 1, and Mode 2. The specific mode is selected with the IM 0, IM 1 and IM 2 (Set Interrupt Mode) instructions. During RESET, the HD64180 is initialized to use Mode 0 for  $\overline{INT}_0$ .

The three interrupt response modes for  $\overline{INT}_0$  are...

- (1) Mode 0 – Instruction fetch from data bus.
- (2) Mode 1 – Restart at logical address 0038H.
- (3) Mode 2 – Low byte vector table address fetch from data bus.

**$\overline{INT}_0$  Mode 0**

During the interrupt acknowledge cycle, an instruction is fetched from the data bus ( $D_0-D_7$ ) at the rising edge of  $T_3$ . Often, this instruction is one of the eight single byte RST (RESTART) instructions which stack the PC and restart execution at a fixed logical address. However, multibyte instructions can be processed if the interrupt acknowledging device can provide a multibyte response. Unlike all other interrupts, the PC is not automatically stacked.

Note that TRAP interrupt will occur if an invalid instruction is fetched during  $\overline{INT}_0$  Mode 0 interrupt acknowledge.

Fig. 24 shows  $\overline{INT}_0$  Mode 0 Timing.

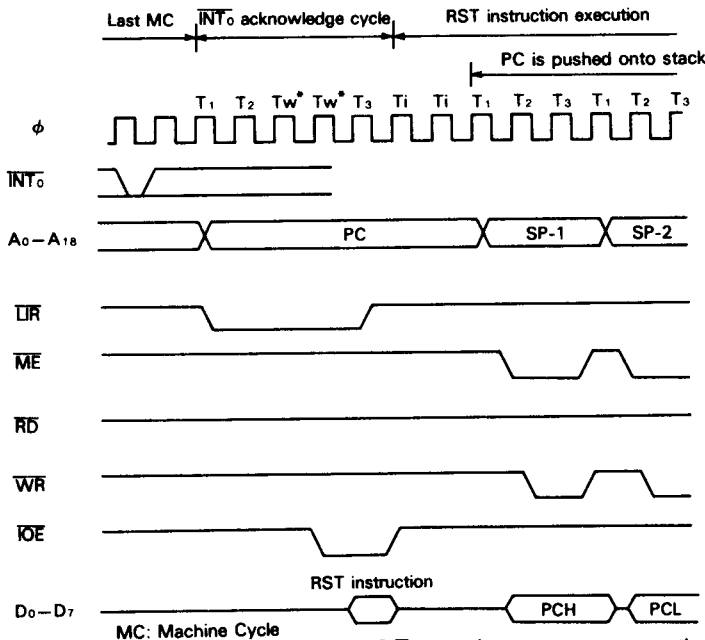

\* Two wait states are automatically inserted.

Figure 24  $\overline{INT}_0$  Mode 0 Timing (RST Instruction on the Data Bus)

# HD64180R/Z

## $\overline{INT}_0$ Mode 1

When  $\overline{INT}_0$  is received, the PC is stacked and instruction execution restarts at logical address 0038H. Both  $IEF_1$  and  $IEF_2$  flags are reset to 0, disabling all maskable interrupts. The interrupt service routine should normally terminate with the EI (Enable Interrupts) instruction followed by the RETI (Return from Interrupt) instruction, so that the interrupts are reenabled. Fig. 25 shows the use of  $\overline{INT}_0$  (Mode 1) and RETI.

Fig. 26 shows  $\overline{INT}_0$  Mode 1 timing.

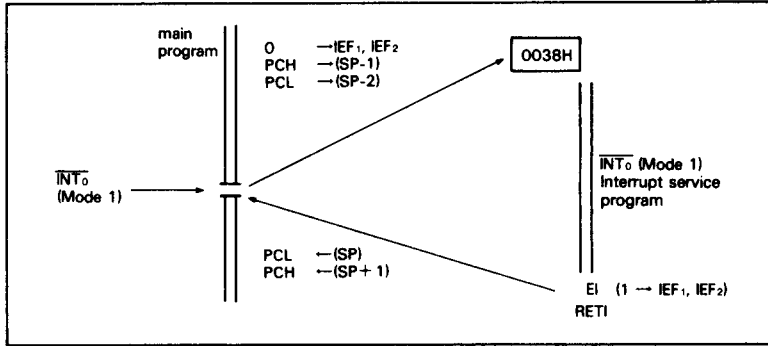
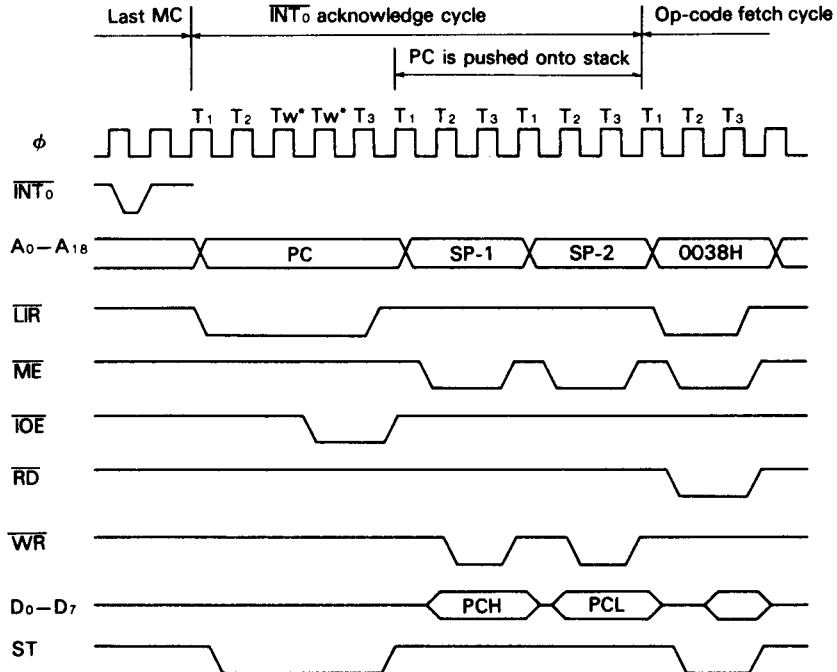

Figure 25  $\overline{INT}_0$  Mode 1 Interrupt Sequence



\* Two wait states are automatically inserted.

Figure 26  $\overline{INT}_0$  Mode 1 Timing



**$\overline{INT}_0$  Mode 2**

This method determines the restart address by reading the contents of a table residing in memory. The vector table consists of up to 128 two-byte restart addresses stored in low byte, high byte order.

The vector table address is located on 256 bytes boundaries in the 64k bytes logical address space as programmed in the 8-bit Interrupt Vector Register (I). Fig. 27 shows the  $\overline{INT}_0$  Mode 2 Vector acquisition.

During  $\overline{INT}_0$  Mode 2 acknowledge cycle, first, the low-order 8 bits of vector is fetched from the data bus at the rising edge of  $T_3$

and CPU acquires the 16-bit vector.

Next, the PC is stacked. Finally, the 16-bit restart address is fetched from the vector table and execution commences at that address.

Note that external vector acquisition is indicated by  $\overline{LIR}$  and  $\overline{IOE}$  both LOW. Two wait states ( $T_w$ ) are automatically inserted for external vector fetch cycles.

During RESET the Interrupt Vector Register (I) is initialized to 00H and, if necessary, should be set to a different value prior to the occurrence of a  $\overline{INT}_0$  Mode 2 interrupt. Fig. 28 shows  $\overline{INT}_0$  Mode 2 interrupt Timing.

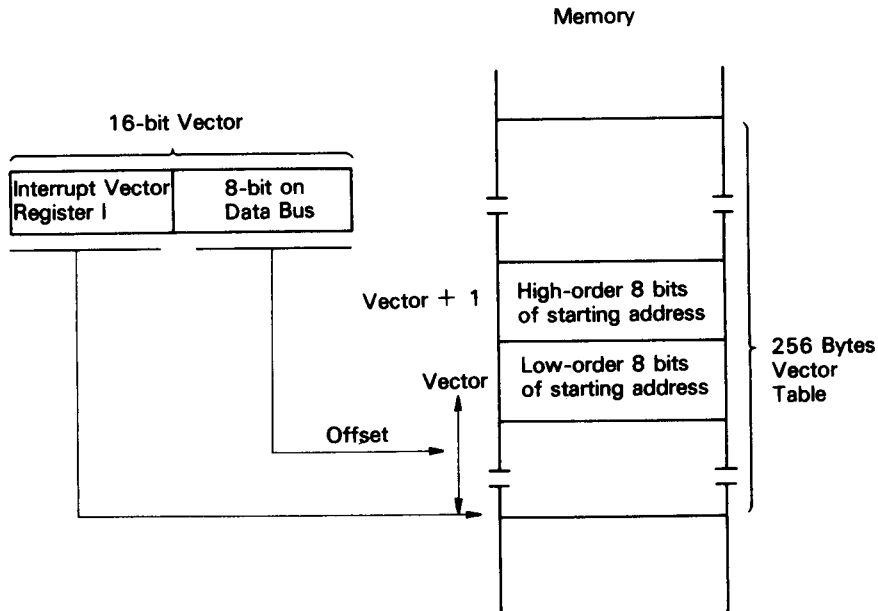
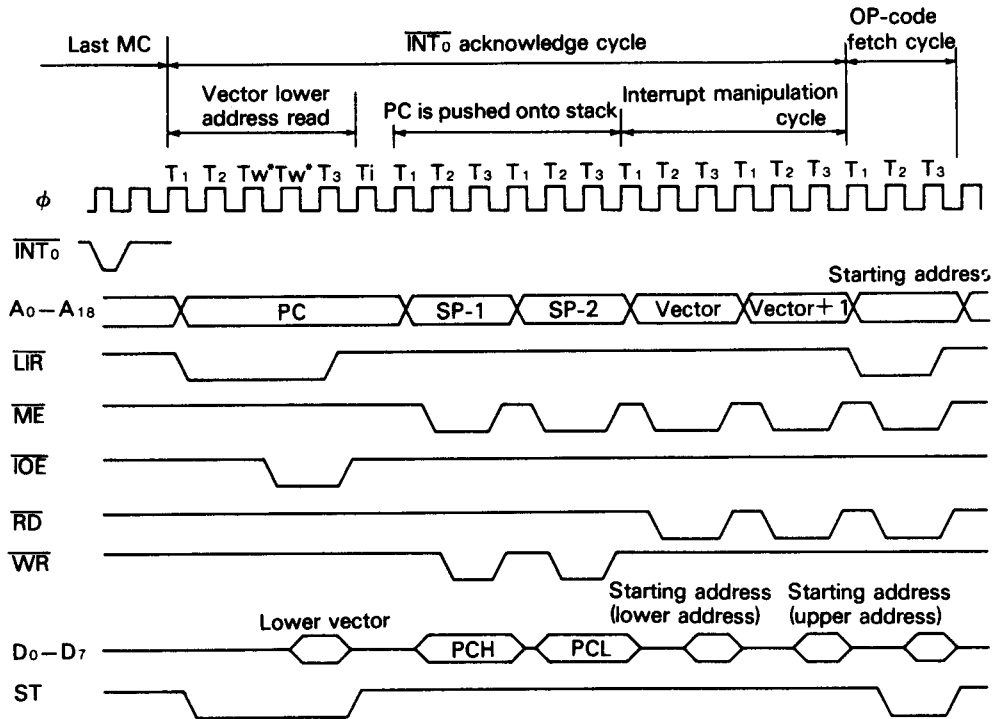

Figure 27  $\overline{INT}_0$  Mode 2 Vector Acquisition



\* Two wait states are automatically inserted.

Figure 28  $\overline{INT}_0$  Mode 2 Timing

### 6.6 $\overline{INT}_1, \overline{INT}_2$

The operation of external interrupts  $\overline{INT}_1$  and  $\overline{INT}_2$  is a vector mode similar to  $\overline{INT}_0$  Mode 2. The difference is that  $\overline{INT}_1$  and  $\overline{INT}_2$  generate the low-order byte of vector table address using the IL (Interrupt Vector Low) register rather than fetching it from the data bus. This is also the interrupt response sequence used for all internal interrupts (except TRAP).

As shown in Fig. 29 the low-order byte of vector table address is comprised of the most significant three bits of the software programmable IL register and the least significant five bits which are a unique fixed value for each interrupt ( $\overline{INT}_1, \overline{INT}_2$  and internal) source.

$\overline{INT}_1$  and  $\overline{INT}_2$  are globally masked by  $IEF_1 = 0$ . Each is also individually maskable by respectively clearing the ITE1 and ITE2 (bits 1, 2) of the INT/TRAP control register to 0.

During RESET, IEF<sub>1</sub>, ITE1 and ITE2 bits are initialized to 0.

### 6.7 Internal Interrupts

Internal interrupts (except TRAP) use the same vectored response mode as  $\overline{INT}_1$  and  $\overline{INT}_2$  (Fig. 29). Internal interrupts are globally masked by  $IEF_1 = 0$ . Individual internal interrupts are enabled/disabled by programming each individual I/O (PRT, DMAC, CSI/O, ASCI) control register. The lower vector of  $\overline{INT}_1, \overline{INT}_2$ , and internal interrupt are summarized in Table 3.

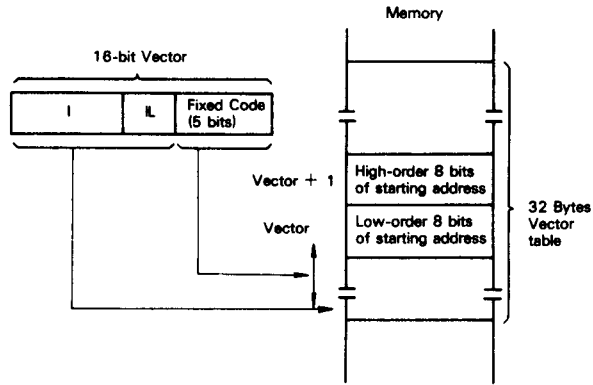

Figure 29  $\overline{INT_1}$ ,  $\overline{INT_2}$  and Internal Interrupts Vector Acquisition

Table 3 Interrupt Source and Lower Vector

Interrupt Source	Priority	IL			Fixed Code				
		b <sub>7</sub>	b <sub>6</sub>	b <sub>5</sub>	b <sub>4</sub>	b <sub>3</sub>	b <sub>2</sub>	b <sub>1</sub>	b <sub>0</sub>
$\overline{INT_1}$	Highest ↑ ↓ Lowest	•	•	•	0	0	0	0	0
$\overline{INT_2}$		•	•	•	0	0	0	1	0
PRT channel 0		•	•	•	0	0	1	0	0
PRT channel 1		•	•	•	0	0	1	1	0
DMA channel 0		•	•	•	0	1	0	0	0
DMA channel 1		•	•	•	0	1	0	1	0
CSI/O		•	•	•	0	1	1	0	0
ASCI channel 0		•	•	•	0	1	1	1	0
ASCI channel 1		•	•	•	1	0	0	0	0

\* Programmable

# HD64180R/Z

## Interrupt Acknowledge Cycle Timing

Fig. 30 shows interrupt acknowledge cycle timing for internal interrupts,  $\overline{INT}_1$ , and  $\overline{INT}_2$ .  $\overline{INT}_1$  and  $\overline{INT}_2$  are sampled at the falling

edge of clock state prior to  $T_3$  or  $T_i$  in the last machine cycle. If  $\overline{INT}_1$  or  $\overline{INT}_2$  is asserted LOW at the falling edge of clock state prior to  $T_3$  or  $T_i$  in the last machine cycle, the interrupt request is accepted.

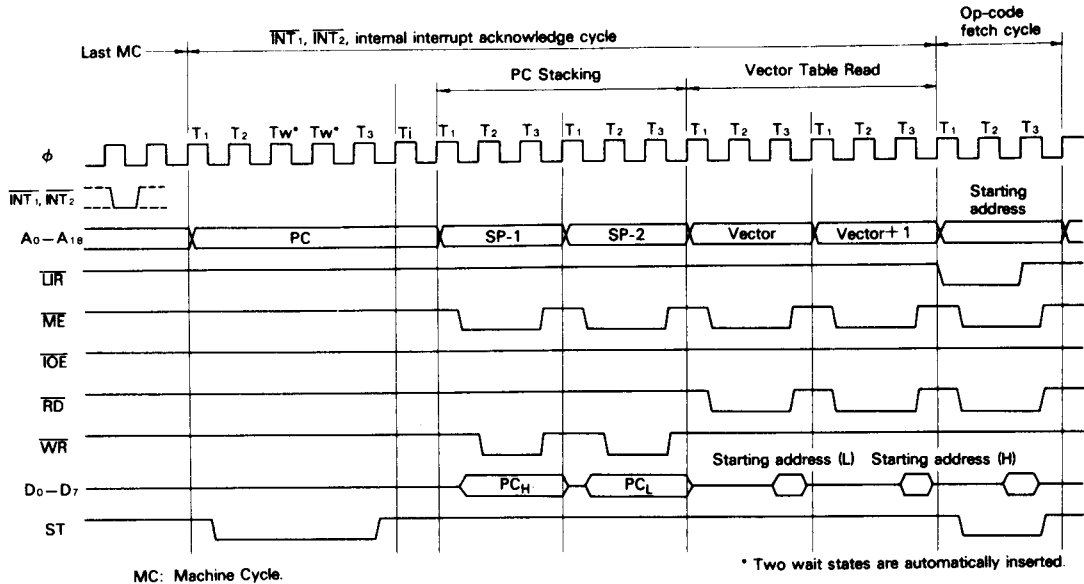

Figure 30  $\overline{INT}_1, \overline{INT}_2$  and Internal Interrupts Timing

## 6.8 Interrupt Sources and Reset

### (1) Interrupt Vector Register (I)

All bits are reset to 0.  
Since I = 0 locates the vector tables starting at logical address 0000H, vectored interrupts ( $\overline{INT}_0$  Mode 2,  $\overline{INT}_1$ ,  $\overline{INT}_2$  and internal interrupts) will overlap with fixed restart interrupts like RESET (0), NMI (0066H),  $\overline{INT}_0$  Mode 1 (0038H) and RST (0000H - 0038H). The vector table(s) can be built elsewhere in memory and located on 256 bytes boundaries by reprogramming I with the LD I, A instruction.

### (2) IL Register

Bits 7 - 5 are reset to 0.  
The IL Register can be programmed to locate the vector table for  $\overline{INT}_1$ ,  $\overline{INT}_2$  and internal interrupts on 32 bytes sub-boundaries within the 256 bytes area specified by I.

### (3) IEF<sub>1</sub>, IEF<sub>2</sub> Flags

Reset to 0.  
Interrupts other than  $\overline{NMI}$  and TRAP are disabled.

### (4) ITC Register

ITE0 are set to 1. ITE1 and ITE2 are reset to 0.  
 $\overline{INT}_0$  can be enabled by the EI instruction, which sets IEF<sub>1</sub> = 1. To enable  $\overline{INT}_1$  and  $\overline{INT}_2$  also requires that the ITE1 and ITE2 bits be respectively set = 1 by writing to ITC.

### (5) I/O Control Registers

Interrupt enable bits reset to 0.  
All HD64180 on-chip I/O (PRT, DMAC, CSI/O, ASCII) interrupts are disabled and can be individually enabled by writing to each I/O control register interrupt enable bit.

## 6.9 Difference between $\overline{INT}_0$ interrupt and the other interrupts ( $\overline{INT}_1$ , $\overline{INT}_2$ and internal interrupts) in the interrupt acknowledge cycles

As shown in Fig. 24, Fig. 26, Fig. 28 and Fig. 30, the interrupt acknowledge cycle of  $\overline{INT}_0$  is different from those of the other interrupts, that is,  $\overline{INT}_1$ ,  $\overline{INT}_2$  and internal interrupts concerning the state of control signals. The state of the control signals in each interrupt acknowledge cycle are shown below.

$\overline{INT}_0$  interrupt acknowledge cycle:  $\overline{LIR} = 0$ ,  $\overline{IOE} = 0$ ,  $\overline{ST} = 0$   
 $\overline{INT}_1, \overline{INT}_2$ , and internal interrupt acknowledge cycle:  $\overline{LIR} = 1$ ,  $\overline{IOE} = 1$ ,  $\overline{ST} = 0$

**7 MEMORY MANAGEMENT UNIT (MMU)**

The HD64180 contains an on-chip MMU which performs the translation of the CPU 64k bytes (16-bit addresses- 0000H to FFFFH) logical memory address space into a 512k bytes (19-bit addresses- 00000H to 7FFFFH) physical memory address space. Address translation occurs internally in parallel with other CPU operation.

**7.1 Logical Address Spaces**

The 64k bytes CPU logical address space is interpreted by the MMU as consisting of up to three separate logical address areas, Common Area 0, Bank Area and Common Area 1.

As shown in Fig. 31 a variety of logical memory configurations are possible. The boundaries between the Common and Bank Areas can be programmed with 4k bytes resolution.

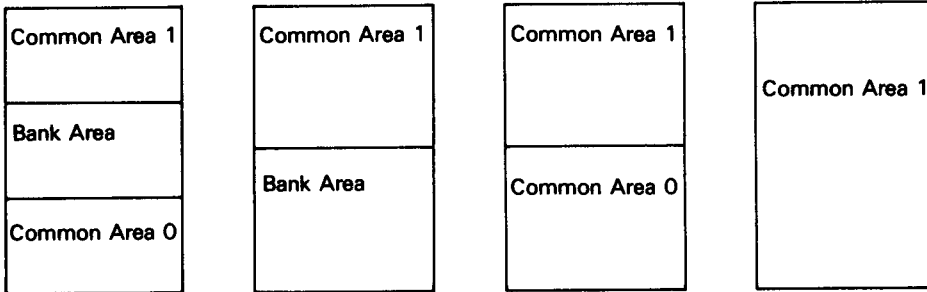

Figure 31 Logical Address Mapping Examples

**7.2 Logical to Physical Address Translation**

Fig. 32 shows an example in which the three logical address space portions are mapped into a 512k bytes physical address space. The important points to note are that Common and Bank Areas can

overlap and that Common Area 1 and Bank Area can be freely relocated (on 4k bytes physical address boundaries). Common Area 0 (if it exists) is always based at physical address 00000H.

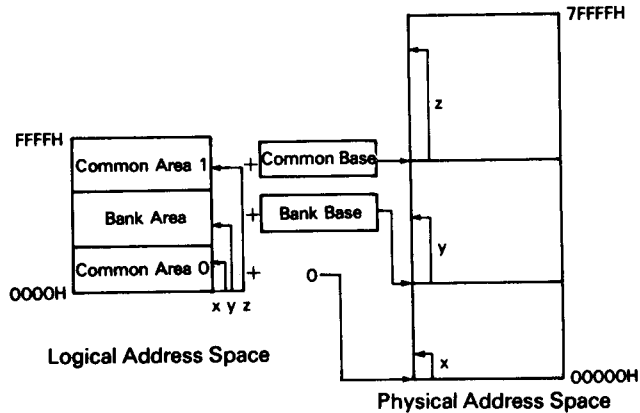

Figure 32 Logical → Physical Memory Mapping Example

# HD64180R/Z

## 7.3 MMU Block Diagram

The MMU block diagram is shown in Fig. 33. The MMU translates internal 16-bit logical addresses to external 19-bit physical addresses.

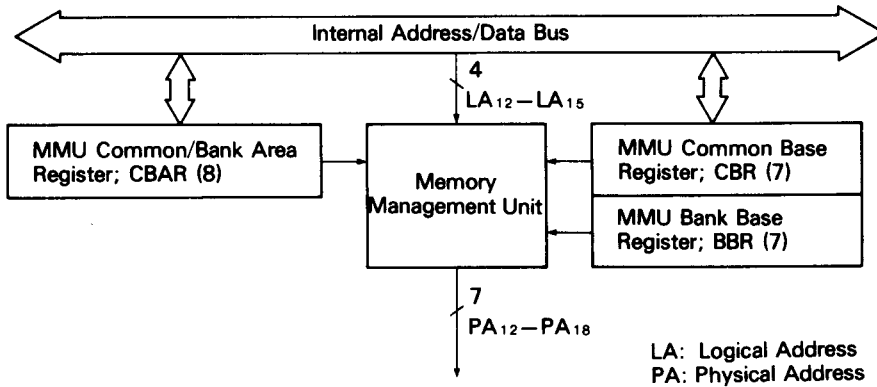

Figure 33 MMU Block Diagram

Whether address translation takes place depends on the type of CPU cycle as follows.

### (1) Memory Cycles

Address Translation occurs for all memory access cycles including instruction and operand fetches, memory data reads and writes, hardware interrupt vector fetch and software interrupt restarts.

### (2) I/O Cycles

The MMU is logically bypassed for I/O cycles. The 16-bit logical I/O address space corresponds directly with the 16-bit physical I/O address space. The upper three bits ( $A_{18}$ - $A_{16}$ ) of the physical address are always 0 during I/O cycles.

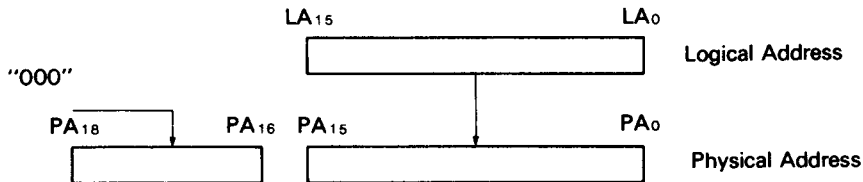

Figure 34 I/O Address Translation

### (3) DMA Cycles

When the HD64180 on-chip DMAC is using the external bus, the MMU is physically bypassed. The 19-bit source and destination

registers in the DMAC are directly output on the physical address bus ( $A_0$ - $A_{18}$ ).

**7.4 MMU Registers**

Three MMU registers are used to program a specific configuration of logical and physical memory.

- (1) MMU Common/Bank Area Register (CBAR)
- (2) MMU Common Base Register (CBR)
- (3) MMU Bank Base Register (BBR)

CBAR is used to define the logical memory organization, while CBR and BBR are used to relocate logical areas within the 512k bytes physical address space. The resolution for both setting boundaries within the logical space and relocation within the physical

space is 4k bytes.

The CAR field of CBAR determines the start address of Common Area 1 (Upper Common) and by default, the end address of the Bank Area. The BAR field determines the start address of the Bank Area and by default, the end address of Common Area 0 (Lower Common).

The CA and BA fields of CBAR may be freely programmed subject only to the restriction that CA may never be less than BA. Fig. 35 and Fig. 36 shows example of logical memory organizations associated with different values of CA and BA.

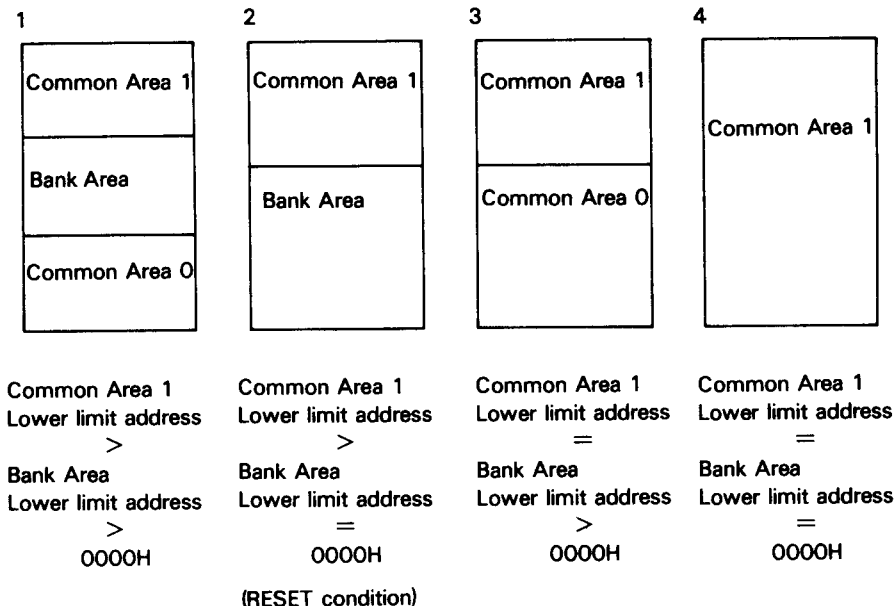

Figure 35 Logical Memory Organization

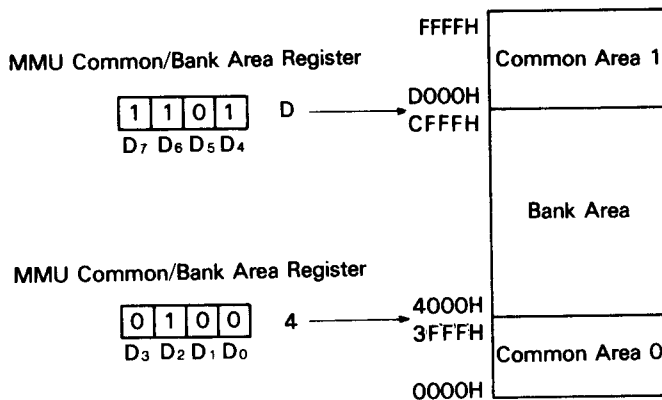

Figure 36 Logical Space Configuration (Example)

# HD64180R/Z

## 7.5 MMU Register Description

### (1) MMU Common/Bank Area Register (CBAR)

CBAR specifies boundaries within the HD64180 64k bytes logical address space for up to three areas, Common Area 0, Bank Area, and Common Area 1.

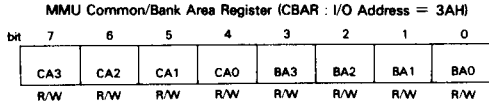

### CA3-CA0: CA (bits 7-4)

CA specifies the start (low) address (on 4k bytes boundaries) for the Common Area 1. This also determines the last address of the Bank Area. All bits of CA are initialized to 1 during RESET.

### BA3-BA0: BA (bits 3-0)

BA specifies the start (low) address (on 4k bytes boundaries) for the Bank Area. This also determines the last address of the Common Area 0. All bits of BA are initialized to 0 during RESET.

### (2) MMU Common Base Register (CBR)

CBR specifies the base address (on 4k bytes boundaries) used to generate a 19-bit physical address for Common Area 1 accesses. All bits of CBR are initialized to 0 during RESET.

MMU Common Base Register (CBR : I/O Address = 3BH)

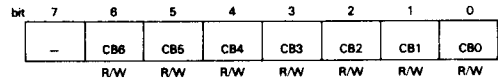

### (3) MMU Bank Base Register (BBR)

BBR specifies the base address (on 4k bytes boundaries) used to generate a 19-bit physical address for Bank Area accesses. All bits of BBR are initialized to 0 during RESET.

MMU Bank Base Register (BBR : I/O Address = 39H)

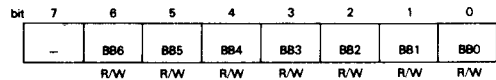

## 7.6 Physical Address Translation

Fig. 37 shows the way in which physical addresses are generated based on the contents of CBAR, CBR and BBR. MMU comparators classify an access by logical area as defined by CBAR. Depending on which of the three potential logical areas (Common Area 1, Bank Area or Common Area 0) is being accessed, the appropriate 7-bit base address is added to the upper 4 bits of the logical address, yielding a 19-bit physical address. CBR is associated with Common Area 1 accesses. Common Area 0 accesses use a (non-accessible, internal) base register which contains 0. Thus, Common Area 0, if defined, is always based at physical address 00000H.

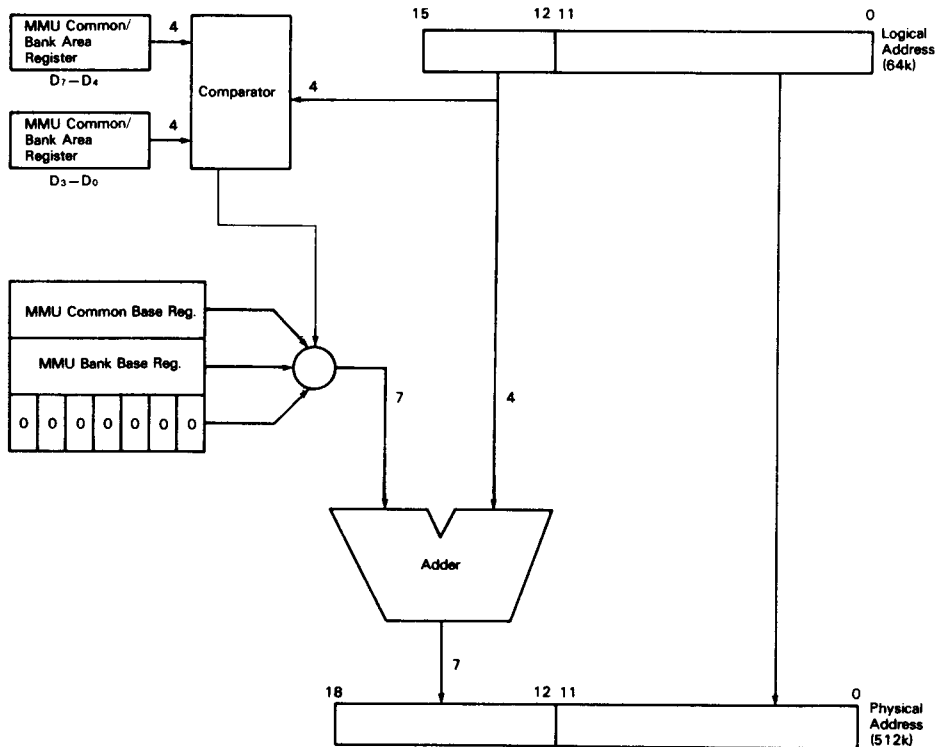

Figure 37 Physical Address Generation



**7.7 MMU and RESET**

During RESET, all bits of the CA field of CBAR are set to 1 while all bits of the BA field of CBAR, CBR, and BBR are cleared to 0. The logical 64k bytes address space corresponds directly with the first 64k bytes (0000H to FFFFH) of the 512k bytes (00000H to 7FFFFH) physical address space. Thus, after RESET, the HD64180 will begin execution at logical and physical address 0.

**7.8 MMU Register Access Timing**

When data is written into CBAR, CBR, or BBR, the value will be effective from the cycle immediately following the I/O write cycle which updates these registers.

Care must be taken during MMU programming to insure that CPU program execution is not disrupted. Observe that the next cycle following MMU register programming will normally be an opcode fetch from the newly translated address. One simple technique is to localize all MMU programming routines in a Common Area that is always enabled.

**8 DYNAMIC RAM REFRESH CONTROL**

The HD64180 incorporates a dynamic RAM refresh control circuit including 8-bit refresh address generation and programmable refresh timing. This circuit generates asynchronous refresh cycles inserted at the programmable interval independent of CPU program execution. For systems which don't use dynamic RAM, the refresh function can be disabled.

When the internal refresh controller determines that a refresh cycle should occur, the current instruction is interrupted at the first breakpoint between machine cycles. The refresh cycle is inserted by placing the refresh address on A<sub>0</sub>-A<sub>7</sub> and the REF output is driven LOW.

Refresh cycles may be programmed to be either two or three clock cycles in duration by programming the REFW (Refresh Wait) bit in Refresh Control Register (RCR). Note that the external WAIT input and the internal wait state generator are not effective during refresh.

Fig. 38 shows the timing of a refresh cycle with a refresh wait (T<sub>RW</sub>) cycle.

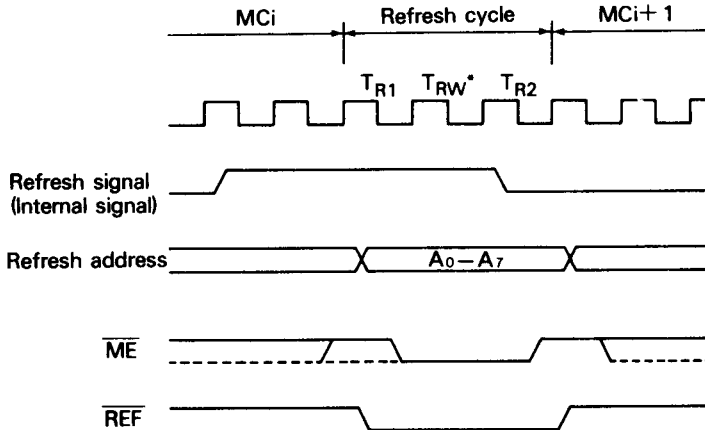

NOTE: \* If three refresh cycles are specified, T<sub>RW</sub> is inserted. Otherwise, T<sub>RW</sub> is not inserted.  
MC: Machine Cycle

Figure 38 Refresh Timing

**8.1 Refresh Control Register (RCR)**

RCR specifies the interval and length of refresh cycles, as well as enabling or disabling the refresh function.

Refresh Control Register (RCR: I/O Address = 36H)

bit 7	6	5	4	3	2	1	0
REFE	REFW	-	-	-	-	CYC1	CYC0
R/W	R/W					R/W	R/W

**REFE: Refresh Enable (bit 7)**

REFE = 0 disables the refresh controller while REFE = 1 enables refresh cycle insertion. REFE is set to 1 during RESET.

**REFW: Refresh Wait (bit 6)**

REFW = 0 causes the refresh cycle to be two clocks in duration. REFW = 1 causes the refresh cycle to be three clocks in duration by adding a refresh wait cycle (T<sub>RW</sub>). REFW is set to 1 during RESET.

**CYC1, 0: Cycle Interval (bits 1-0)**

CYC1 and CYC0 specify the interval (in clock cycles) between refresh cycles.

In the case of dynamic RAMs requiring 128 refresh cycles every 2 ms (or 256 cycles every 4 ms), the required refresh interval is less than or equal to 15.625 μs. Thus, the underlined values indicate the best refresh interval depending on CPU clock frequency. CYC0 and CYC1 are cleared to 0 during RESET.

Table 4 Refresh Interval

CYC1	CYC0	insertion interval	Time interval				
			$\phi$ : 10 MHz	8 MHz	6 MHz	4 MHz	2.5 MHz
0	0	10 states	(1.0 $\mu$ s)*	(1.25 $\mu$ s)*	1.66 $\mu$ s	2.5 $\mu$ s	4.0 $\mu$ s
0	1	20 states	(2.0 $\mu$ s)*	(2.5 $\mu$ s)*	3.3 $\mu$ s	5.0 $\mu$ s	8.0 $\mu$ s
1	0	40 states	(4.0 $\mu$ s)*	(5.0 $\mu$ s)*	6.6 $\mu$ s	10.0 $\mu$ s	16.0 $\mu$ s
1	1	80 states	(8.0 $\mu$ s)*	(10.0 $\mu$ s)*	13.3 $\mu$ s	20.0 $\mu$ s	32.0 $\mu$ s

\* calculated interval

**8.2 Refresh control and reset**

After RESET, based on the initialized value of RCR, refresh cycles will occur with an interval of 10 clock cycles and be 3 clock cycles in duration.

**8.3 Dynamic RAM refresh operation notes**

- (1) Refresh cycle insertion is stopped when the CPU is in the following states.
  - (a) During RESET
  - (b) When the bus is released in response to  $\overline{\text{BUSREQ}}$
  - (c) During SLEEP mode
  - (d) During WAIT states
- (2) Refresh cycles are suppressed when the bus is released in response to  $\overline{\text{BUSREQ}}$ . However, the refresh timer continues to operate. Thus, the time at which the first refresh cycle occurs after the HD64180 re-acquires the bus depends on the refresh timer, and has no timing relationship with the bus exchange.
- (3) Refresh cycles are suppressed during SLEEP mode. If a refresh cycle is requested during SLEEP mode, the refresh cycle request is internally 'latched' (until replaced with the next refresh request). The 'latched' refresh cycle is inserted at the end of the first machine cycle after SLEEP mode is exited. After this initial cycle, the time at which the next refresh cycle will occur depending on the refresh time, and has no timing relationship with the exit from SLEEP mode.
- (4) Regarding (2) and (3), the refresh address is incremented by 1 for each successful refresh cycle, not for each refresh request. Thus, independent of the number of 'missed' refresh requests, each refresh bus cycle will use a refresh address incremented by 1 from that of the previous refresh bus cycles.

**9 WAIT STATE GENERATOR**

**9.1 Wait State Timing**

To ease interfacing with slow memory and I/O devices, the HD64180 uses wait states ( $T_w$ ) to extend bus cycle timing. A wait state(s) is inserted based on the combined (logical OR) state of the external WAIT input and an internal programmable wait state ( $T_w$ ) generator. Wait states ( $T_w$ ) can be inserted in both CPU execution and DMA transfer cycles.

**9.2 WAIT Input**

When the external  $\overline{\text{WAIT}}$  input is asserted LOW, wait state ( $T_w$ ) are inserted between  $T_2$  and  $T_3$  to extend the bus cycle duration. The WAIT input is sampled at the falling edge of the system clock in  $T_2$  or  $T_w$ . If the WAIT input is asserted LOW at the falling edge of the system clock in  $T_w$ , another  $T_w$  is inserted into the bus cycle. Note that WAIT input transitions must meet specified set-up and hold times. This can easily be accomplished by externally synchronizing WAIT input transitions with the rising edge of the system clock.

Dynamic RAM refresh is not performed during wait states ( $T_w$ ) and thus systems designs which uses the automatic refresh function must consider the affects of the occurrence and duration of wait states ( $T_w$ ).

Fig. 39 shows  $\overline{\text{WAIT}}$  timing.

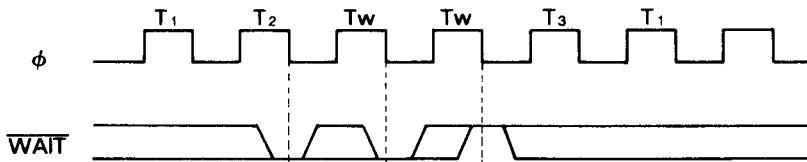
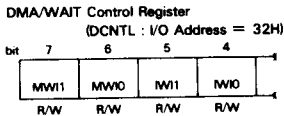

Figure 39  $\overline{\text{WAIT}}$  Timing

**9.3 Programmable Wait State Insertion**

In addition to the  $\overline{\text{WAIT}}$  input, wait states ( $T_w$ ) can also be programmably inserted using the HD64180 on-chip wait state generator. Wait state ( $T_w$ ) timing applies for both CPU execution and on-chip DMAC cycles.

By programming the 4 significant bits of the DMA/WAIT Control Register (DCNTL), the number of wait states ( $T_w$ ) automatically inserted in memory and I/O cycles can be separately specified. Bits 4-5 specify the number of wait states ( $T_w$ ) inserted for I/O access and bits 6-7 specify the number of wait states ( $T_w$ ) inserted for memory access.



The number of wait states ( $T_w$ ) inserted in a specific cycle is the maximum of the number requested by the  $\overline{\text{WAIT}}$  input, and the

number automatically generated by the on-chip wait state generator.

**MW11, MWIO: Memory Wait Insertion (bits 7-6)**

For CPU and DMAC cycles which access memory (including memory mapped I/O), 0 to 3 wait states may be automatically inserted depending on the programmed value in MW11 and MWIO.

MW11	MWIO	The number of wait states
0	0	0
0	1	1
1	0	2
1	1	3

**IW11, IWIO: I/O Wait Insertion (bits 5-4)**

For CPU and DMA cycles which access external I/O (and interrupt acknowledge cycles), 1 to 6 wait states ( $T_w$ ) may be automatically inserted depending on the programmed value in IW11 and IWIO.

IW11	IWIO	The number of wait states				
		For external I/O registers accesses	For internal I/O registers accesses	For $\overline{\text{INT}}_0$ interrupt acknowledge cycles when $\overline{\text{LIR}}$ is LOW	For $\overline{\text{INT}}_1$ , $\overline{\text{INT}}_2$ and internal interrupts acknowledge cycles (Note (2))	For NMI interrupt acknowledge cycles when $\overline{\text{LIR}}$ is LOW (Note (2))
0	0	1	0 (Note (1))	2	2	0
0	1	2		4		
1	0	3		5		
1	1	4		6		

NOTE: (1) For HD64180 internal I/O register access (I/O addresses 0000H-003FH), IW11 and IWIO do not determine wait state ( $T_w$ ) timing. For ASCII, CSI/O and PRT Data Register accesses, 0 to 4 wait states ( $T_w$ ) will be generated. Wait states inserted during access to these registers is a function of internal synchronization requirements and CPU state.

All other on-chip I/O register accesses (i.e. MMU, DMAC, ASCII Control Registers, etc.) have 0 wait states inserted and thus require only three clock cycles.

(2) For interrupt acknowledge cycles in which  $\overline{\text{LIR}}$  is HIGH, such as interrupt vector table read and PC stacking cycle, memory access timing applies.

**9.4 WAIT Input and RESET**

During RESET, MW11, MWIO, IW11 and IWIO are all set to 1, selecting the maximum number of wait states ( $T_w$ ) (3 for memory accesses, 4 for external I/O accesses).

Also, note that the  $\overline{\text{WAIT}}$  input is ignored during RESET. For

example, if RESET is detected while the HD64180 is in a wait state ( $T_w$ ), the wait stated cycle in progress will be aborted, and the RESET sequence initiated. Thus, RESET has higher priority than WAIT.

# HD64180R/Z

## 10 DMA CONTROLLER (DMAC)

The HD64180 contains a two channel DMA (Direct Memory Access) controller which supports high speed data transfer. Both channels (channel 0 and channel 1) have the following capabilities.

### Memory Address Space

Memory source and destination addresses can be directly specified anywhere within the 512k bytes physical address space using 19-bit source and destination memory addresses. In addition, memory transfers can arbitrarily cross 64k bytes physical address boundaries without CPU intervention.

### I/O Address Space

I/O source and destination addresses can be directly specified anywhere within the 64k bytes I/O address space (16-bit source and destination I/O addresses).

### Transfer Length

Up to 64k bytes can be transferred based on a 16-bit byte count register.

### DREQ Input

Level and edge sense  $\overline{\text{DREQ}}$  input detection are selectable.

### TEND Output

Used to indicate DMA completion to external devices.

### Transfer Rate

Each byte transfer can occur every six clock cycles. Wait states can be inserted in DMA cycles for slow memory or I/O devices. At the system clock ( $\phi$ ) = 6 MHz, the DMA transfer rate is as high as 1.0 megabytes/second (no wait states).

Additional feature disk for DMA interrupt request by DMA END.

Each channel has the following additional specific capabilities.

### Channel 0

- Memory  $\longleftrightarrow$  memory, memory  $\longleftrightarrow$  I/O, memory  $\longleftrightarrow$  memory mapped I/O transfers
- Memory address increment, decrement, no-change
- Burst or cycle steal memory  $\longleftrightarrow$  memory transfers
- DMA to and from both ASCII channels
- Higher priority than DMAC channel 1

### Channel 1

- Memory  $\longleftrightarrow$  I/O transfer
- Memory address increment, decrement

### DMAC Registers

Each channel of the DMAC (channel 0, 1) has three registers specifically associated with that channel.

#### Channel 0

- SAR0 – Source Address Register
- DAR0 – Destination Address Register
- BCR0 – Byte Count Register

#### Channel 1

- MAR1 – Memory Address Register
- IAR1 – I/O Address Register
- BCR1 – Byte Count Register

The two channels share the following three additional registers in common.

- DSTAT – DMA Status Register
- DMODE – DMA Mode Register
- DCNTL – DMA Control Register

## 10.1 DMAC Block Diagram

Fig. 40 shows the HD64180 DMAC Block Diagram.

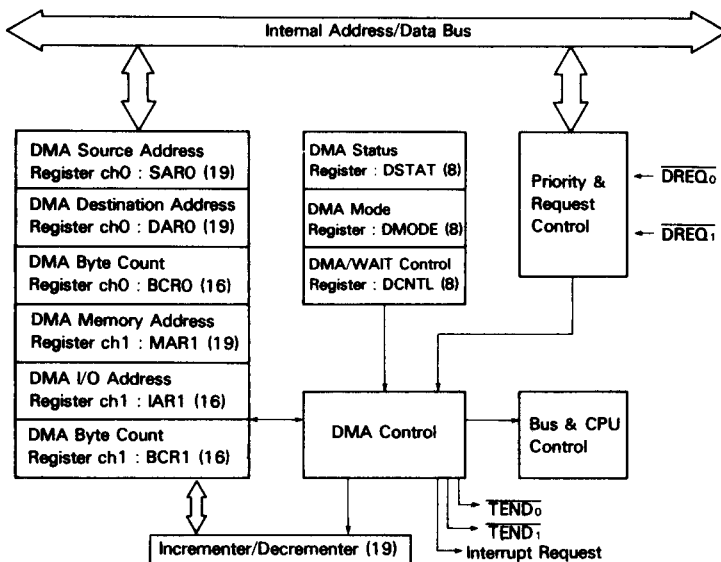
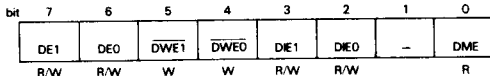

Figure 40 DMAC Block Diagram

10.2 DMAC Register Description

- (1) DMA Source Address Register Channel 0 (SAR0: I/O Address = 20H to 22H)**  
Specifies the physical source address for channel 0 transfers. The register contains 19 bits and may specify up to 512k bytes memory addresses or up to 64k bytes I/O addresses. Channel 0 source can be memory, I/O or memory mapped I/O.
- (2) DMA Destination Address Register Channel 0 (DAR0: I/O Address = 23H to 25H)**  
Specifies the physical destination address for channel 0 transfers. The register contains 19 bits and may specify up to 512k bytes memory addresses or up to 64k bytes I/O addresses. Channel 0 destination can be memory, I/O or memory mapped I/O.
- (3) DMA Byte Count Register Channel 0 (BCR0: I/O Address = 26H to 27H)**  
Specifies the number of bytes to be transferred. This register contains 16 bits and may specify up to 64k bytes transfers. When one byte is transferred, the register is decremented by one. If "n" bytes should be transferred, "n" must be stored before the DMA operation.
- (4) DMA Memory Address Register Channel 1 (MAR1: I/O Address = 28H to 2AH)**  
Specifies the physical memory address for channel 1 transfers. This may be destination or source memory address. This register contains 19 bits and may specify up to 512k bytes memory addresses.
- (5) DMA I/O Address Register Channel 1 (IAR1: I/O Address = 2BH to 2CH)**  
Specifies the I/O address for channel 1 transfers. This may be destination or source I/O address. This register contains 16 bits and may specify up to 64k bytes I/O addresses.
- (6) DMA Byte Count Register Channel 1 (BCR1: I/O Address = 2EH to 2FH)**  
Specifies the number of bytes to be transferred. This register contains 16 bits and may specify up to 64k bytes transfers. When one byte is transferred, the register is decremented by one.
- (7) DMA Status Register (DSTAT)**  
DSTAT is used to enable and disable DMA transfer and DMA termination interrupts. DSTAT also allows determining the status of a DMA transfer i.e. completed or in progress.

DMA Status Register (DSTAT : I/O Address = 30H)



**DE1: DMA Enable Channel 1 (bit 7)**  
When DE1 = 1 and DME = 1, channel 1 DMA is enabled. When a DMA transfer terminates (BCR1 = 0), DE1 is reset to 0 by the DMAC. When DE1 = 0 and the DMA interrupt is enabled (DIE1 = 1), a DMA interrupt request is made to the CPU.  
To perform a software write to DE1, DWE1 should be written with 0 during the same register write access. Writing DE1 to 0 disables channel 1 DMA, but DMA is restartable. Writing DE1 to 1 enables channel 1 DMA and automatically sets DME (DMA Main Enable) to 1. DE1 is cleared to 0 during RESET.

**DE0: DMA Enable Channel 0 (bit 6)**  
When DE0 = 1 and DME = 1, channel 0 DMA is enabled. When a DMA transfer terminates (BCR0 = 0), DE0 is cleared to 0 by the DMAC. When DE0 = 0 and the DMA interrupt is enabled

(DIE0 = 1), a DMA interrupt request is made to the CPU.  
To perform a software write to DE0, DWE0 should be written with 0 during the same register write access. Writing DE0 to 0 disables channel 0 DMA. Writing DE0 to 1 enables channel 0 DMA and automatically sets DME (DMA Main Enable) to 1. DE0 is cleared to 0 during RESET.

**DWE1: DE1 Bit Write Enable (bit 5)**  
When performing any software write to DE1, DWE1 should be written with 0 during the same access. DWE1 write value of 0 is not held and DWE1 is always read as 1.

**DWE0: DE0 Bit Write Enable (bit 4)**  
When performing any software write to DE0, DWE0 should be written with 0 during the same access. DWE0 write value of 0 is not held and DWE0 is always read as 1.

**DIE1: DMA Interrupt Enable Channel 1 (bit 3)**  
When DIE1 is set to 1, the termination of channel 1 DMA transfer (indicated when DE1 = 0) causes a CPU interrupt request to be generated. When DIE1 = 0, the channel 1 DMA termination interrupt is disabled. DIE1 is cleared to 0 during RESET.

**DIE0: DMA Interrupt Enable Channel 0 (bit 2)**  
When DIE0 is set to 1, the termination channel 0 of DMA transfer (indicated when DE0 = 0) causes a CPU interrupt request to be generated. When DIE0 = 0, the channel 0 DMA termination interrupt is disabled. DIE0 is cleared to 0 during RESET.

**DME: DMA Main Enable (bit 0)**  
A DMA operation is only enabled when its DE bit (DE0 for channel 0, DE1 for channel 1) and the DME bit are set to 1.  
When NMI occurs, DME is reset to 0, thus disabling DMA activity during the NMI interrupt service routine. To restart DMA, DE0 and/or DE1 should be written with 1 (even if the contents are already 1). This automatically sets DME to 1, allowing DMA operations to continue. Note that DME cannot be directly written. It is cleared to 0 by NMI or indirectly set to 1 by setting DE0 and/or DE1 to 1. DME is cleared to 0 during RESET.

**(8) DMA Mode Register (DMODE)**  
DMODE is used to set the addressing and transfer mode for channel 0.

DMA Mode Register (DMODE : I/O Address = 31H)

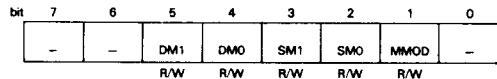

**DM1, DM0: Destination Mode Channel 0 (bits 5, 4)**  
Specifies whether the destination for channel 0 transfers is memory, I/O or memory mapped I/O and the corresponding address modifier. DM1 and DM0 are cleared to 0 during RESET.

Table 5 Destination

DM1	DM0	Memory/I/O	Address Increment/Decrement
0	0	Memory	+1
0	1	Memory	-1
1	0	Memory	fixed
1	1	I/O	fixed



# HD64180R/Z

## SM1, SM0: Source Mode Channel 0 (bits 3, 2)

Specifies whether the source for channel 0 transfers is memory, I/O or memory mapped I/O and the corresponding address modifier. SM1 and SM0 are cleared to 0 during RESET.

Table 7 shows all DMA transfer mode combinations of DM0, DM1, SM0, SM1. Since I/O  $\longleftrightarrow$  I/O transfers are not implemented, twelve combinations are available.

Table 6 Source

SM1	SM0	Memory/I/O	Address Increment/Decrement
0	0	Memory	+1
0	1	Memory	-1
1	0	Memory	fixed
1	1	I/O	fixed

Table 7 Combination of Transfer Mode

DM1	DM0	SM1	SM0	Transfer Mode	Address Increment/Decrement
0	0	0	0	Memory→Memory	SARO+1, DARO+1
0	0	0	1	Memory→Memory	SARO-1, DARO+1
0	0	1	0	Memory*→Memory	SARO fixed, DARO+1
0	0	1	1	I/O→Memory	SARO fixed, DARO+1
0	1	0	0	Memory→Memory	SARO+1, DARO-1
0	1	0	1	Memory→Memory	SARO-1, DARO-1
0	1	1	0	Memory*→Memory	SARO fixed, DARO-1
0	1	1	1	I/O→Memory	SARO fixed, DARO-1
1	0	0	0	Memory→Memory*	SARO+1, DARO fixed
1	0	0	1	Memory→Memory*	SARO-1, DARO fixed
1	0	1	0	reserved	
1	0	1	1	reserved	
1	1	0	0	Memory→I/O	SARO+1, DARO fixed
1	1	0	1	Memory→I/O	SARO-1, DARO fixed
1	1	1	0	reserved	
1	1	1	1	reserved	

\* : includes memory mapped I/O

## MMOD: Memory Mode Channel 0 (bit 1)

When channel 0 is configured for memory  $\longleftrightarrow$  memory transfers, the external DREQ<sub>0</sub> input is not used to control the transfer timing. Instead, two automatic transfer timing modes are selectable - burst (MMOD = 1) and cycle steal (MMOD = 0). For burst memory  $\longleftrightarrow$  memory transfers, the DMAC will seize control of the bus continuously until the DMA transfer completes (as shown by the byte count register = 0). In cycle steal mode, the CPU is given a cycle for each DMA byte transfer cycle until the transfer is completed.

For channel 0 DMA with I/O source or destination, the DREQ<sub>0</sub> input times the transfer and thus MMOD is ignored. MMOD is cleared to 0 during RESET.

## DMA/WAIT Control Register (DCNTL)

DCNTL controls the insertion of wait states into DMAC (and CPU) accesses of memory or I/O. Also, the DMA request mode for each DREQ (DREQ<sub>0</sub> and DREQ<sub>1</sub>) input is defined as level or edge sense. DCNTL also sets the DMA transfer mode for channel 1, which is limited to memory  $\longleftrightarrow$  I/O transfers.

DMA/WAIT Control Register (DCNTL : I/O Address = 32H)

bit	7	6	5	4	3	2	1	0
	MW1	MW0	IW1	IW0	DMS1	DMS0	DIM1	DIM0
	R/W	R/W	R/W	R/W	R/W	R/W	R/W	R/W

## MW1, MW0: Memory Wait Insertion (bits 7-6)

Specifies the number of wait states introduced into CPU or DMAC memory access cycles. MW1 and MW0 are set to 1 during RESET. See section of Wait State Control for details.

## IW1, IW0: I/O Wait Insertion (bits 5-4)

Specifies the number of wait states introduced into CPU or DMAC I/O access cycles. IW1 and IW0 are set to 1 during RESET. See section of Wait State Control for details.

## DMS1, DMS0: DMA Request Sense (bits 3-2)

DMS1 and DMS0 specify the DMA request sense for channel 0 (DREQ<sub>0</sub>) and channel 1 (DREQ<sub>1</sub>) respectively. When reset to 0, the input is level sense. When set to 1, the input is edge sense. DMS1 and DMS0 are cleared to 0 during RESET.

## DIM1, DIM0: DMA Channel 1 I/O and Memory Mode (bits 1-0)

Specifies the source/destination and address modifier for channel 1 memory  $\longleftrightarrow$  I/O transfer modes. IM1 and IM0 are cleared to 0 during RESET.

Table 8 Channel 1 Transfer Mode

DIM1	DIM0	Transfer Mode	Address Increment/Decrement
0	0	Memory→I/O	MAR1+1, IAR1 fixed
0	1	Memory→I/O	MAR1-1, IAR1 fixed
1	0	I/O→Memory	IAR1 fixed, MAR1+1
1	1	I/O→Memory	IAR1 fixed, MAR1-1

## 10.3 DMA Operation

This section discusses the three DMA operation modes for channel 0, memory  $\longleftrightarrow$  memory, memory  $\longleftrightarrow$  I/O and memory  $\longleftrightarrow$  memory mapped I/O. In addition, the operation of channel 0 DMA with the on-chip ASCI (Asynchronous Serial Communication Interface) as well as Channel 1 DMA are described.

**(1) Memory ↔ Memory – Channel 0**

For memory ↔ memory transfers, the external  $\overline{DREQ}_0$  input is not used for DMA transfer timing. Rather, the DMA operation is timed in one of two programmable modes – burst or cycle steal. In both modes, the DMA operation will automatically proceed until termination as shown by byte count (BCR0) = 0.

In burst mode, the DMA operation will proceed until termination. In this case, the CPU cannot perform any program execution

until the DMA operation is completed.

In cycle steal mode, the DMA and CPU operation are alternated after each DMA byte transfer until the DMA is completed. The sequence ...



... is repeated until DMA is completed. Fig. 41 shows cycle steal mode DMA timing.

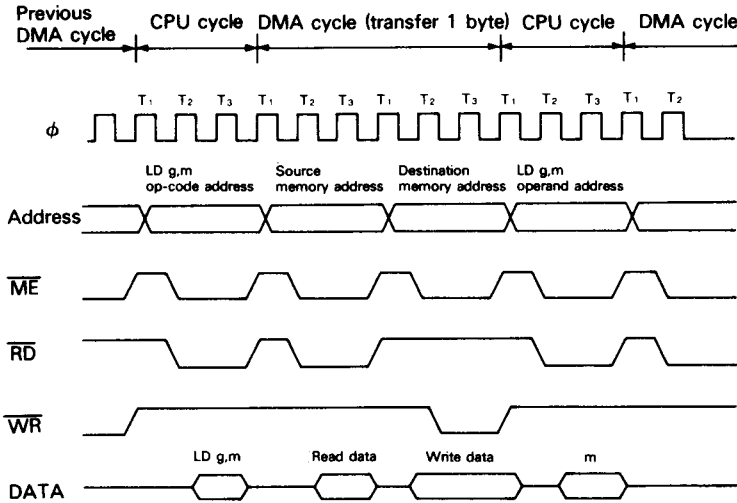

Figure 41 Cycle Steal Mode DMA Timing

To initiate memory ↔ memory DMA transfer for channel 0, perform the following operations.

- ① Load the memory source and destination addresses into SAR0 and DAR0.
- ② Specify memory ↔ memory mode and address increment/decrement in the SM0, SM1, DM0 and DM1 bits of DMODE.
- ③ Load the number of bytes to transfer in BCR0.
- ④ Specify burst or cycle steal mode in the MMOD bit of DCNTL.
- ⑤ Program DE0 = 1 (with  $\overline{DWE0} = 0$  in the same access) in DSTAT and the DMA operation will start 1 machine cycle later. If interrupt occurs at the same time, the DIE0 bit should be set to 1.

**(2) Memory ↔ I/O (Memory Mapped I/O) – Channel 0**

For memory ↔ I/O (and memory ↔ memory mapped I/O) the  $\overline{DREQ}_0$  input is used to time the DMA transfers. In addition, the  $\overline{TEND}_0$  (Transfer End) output is used to indicate the last (byte count register BCR0 = 00H) transfer.

The  $\overline{DREQ}_0$  input can be programmed as level or edge sensitive.

When level sense is programmed, the DMA operation begins when  $\overline{DREQ}_0$  is sampled LOW. If  $\overline{DREQ}_0$  is sampled HIGH, after the next DMA byte transfer, control is relinquished to the HD64180 CPU. As shown in Fig. 42.  $\overline{DREQ}_0$  is sampled at the rising edge of the clock cycle prior to T<sub>3</sub> i.e. either T<sub>2</sub> or T<sub>w</sub>.

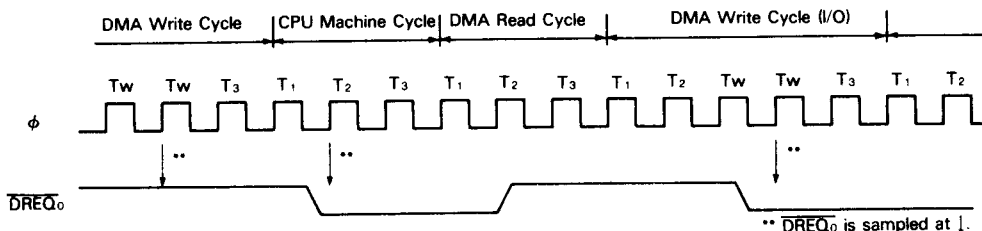

Figure 42 CPU Operation and DMA Operation ( $\overline{DREQ}_0$  is programmed for level sense)

## HD64180R/Z

When edge sense is programmed, DMA operation begins at the falling edge of  $\overline{DREQ}_0$ . If another falling edge is detected before the rising edge of the clock prior to  $T_3$  during DMA write cycle (i.e.  $T_2$  or  $T_w$ ), the DMAC continues operating. If an edge is not detected, the CPU is given control after the current byte DMA transfer com-

pletes. The CPU will continue operating until a  $\overline{DREQ}_0$  falling edge is detected before the rising edge of the clock prior to  $T_3$  at which time the DMA operation will (re)start. Fig. 43 shows the edge sense DMA timing.

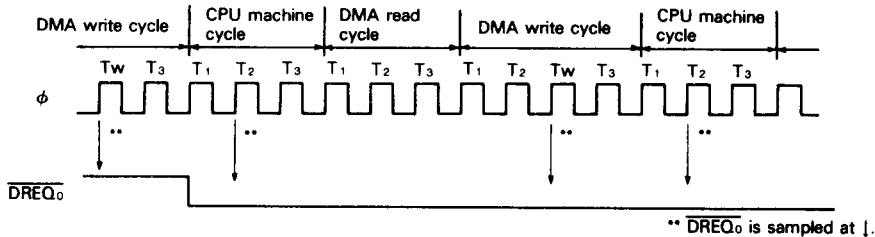

Figure 43 CPU Operation and DMA Operation  
( $\overline{DREQ}_0$  is programmed for edge sense)

During the transfers for channel 0, the  $\overline{TEND}_0$  output will go LOW synchronous with the write cycle of the last (BCR0 = 00H)

DMA transfer as shown in Fig. 44.

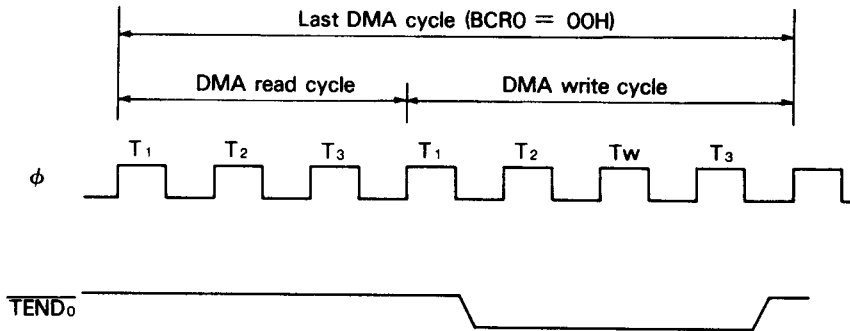

Figure 44  $\overline{TEND}_0$  Output Timing

The  $\overline{DREQ}_0$  and  $\overline{TEND}_0$  pins are programmably multiplexed with the CKA0 and CKA1 ASCII clock input/outputs. However, when DMA channel 0 is programmed for memory  $\leftrightarrow$  I/O (and memory  $\leftrightarrow$  memory mapped I/O) transfers, the CKA0/ $\overline{DREQ}_0$  pin automatically functions as input pin even if it has been programmed as output pin for CKA0. And the CKA1/ $\overline{TEND}_0$  pin functions as output pin for  $\overline{TEND}_0$  by setting CKA1D to 1 in CNTLA1.

To initiate memory  $\leftrightarrow$  I/O (and memory  $\leftrightarrow$  memory mapped I/O) DMA transfer for channel 0, perform the following operations.

- ① Load the memory and I/O or memory mapped I/O source and destination addresses into SAR0 and DAR0. Note that I/O addresses (not memory mapped I/O) are limited to 16 bits ( $A_0$ - $A_{15}$ ). Make sure that bits  $A_{16}$  and  $A_{17}$  are 0 ( $A_{18}$  is a don't care) to correctly enable the external  $\overline{DREQ}_0$  input.
- ② Specify memory  $\leftrightarrow$  I/O or memory  $\leftrightarrow$  memory mapped I/O mode and address increment/decrement in the SM0, SM1, DM0, and DM1 bits of DMODE.
- ③ Load the number of bytes to transfer in BCR0.
- ④ Specify whether  $\overline{DREQ}_0$  is edge or level sense by programming the DMS0 bit of DCNTL.
- ⑤ Enable or disable DMA termination interrupt with the DIE0 bit in DSTAT.
- ⑥ Program DE0 = 1 (with  $\overline{DWE0}$  = 0 in the same access) in

DSTAT and the DMA operation will begin under the control of the  $\overline{DREQ}_0$  input.

### (3) Memory $\leftrightarrow$ ASCII - Channel 0

Channel 0 has extra capability to support DMA transfer to and from the on-chip two channel ASCII. In this case the external  $\overline{DREQ}_0$  input is not used for DMA timing. Rather, the ASCII status bits are used to generate an internal  $\overline{DREQ}_0$ . The TDRE (Transmit Data Register Empty) bit and the RDRF (Receive Data Register Full) bit are used to generate an internal  $\overline{DREQ}_0$  for ASCII transmission and reception respectively.

To initiate memory  $\leftrightarrow$  ASCII DMA transfer, perform the following operations.

- ① Load the source and destination addresses into SAR0 and DAR0. Specify the I/O (ASCII) address as follows.  
Bits  $A_0$ - $A_7$  should be contain the address of the ASCII channel transmitter or receiver (I/O addresses 06H-09H).  
Bits  $A_8$ - $A_{15}$  should equal 0.  
Bits  $A_{17}$ - $A_{16}$  should be set according to the following table to enable use of the appropriate ASCII status bit as an internal DMA request.



Table 9 DMA Request

SAR18	SAR17	SAR16	DMA Transfer Request
X	0	0	DREQ <sub>0</sub>
X	0	1	RDRF (ASCI channel 0)
X	1	0	RDRF (ASCI channel 1)
X	1	1	reserved

X: Don't care

DAR18	DAR17	DAR16	DMA Transfer Request
X	0	0	DREQ <sub>0</sub>
X	0	1	TDRE (ASCI channel 0)
X	1	0	TDRE (ASCI channel 1)
X	1	1	reserved

X: Don't care

- ② Specify memory ↔ I/O transfer mode and address increment/decrement in the SM0, SM1, DM0 and DM1 bits of DMODE.
- ③ Load the number of bytes to transfer in BCR0.
- ④ The DMA request sense mode (DMS0 bit in DCNTL) MUST be specified as 'edge sense'.
- ⑤ Enable or disable DMA termination interrupt with the DIE0 bit in DSTAT.
- ⑥ Program DE0 = 1 (with DWE0 = 0 in the same access) in DSTAT and the DMA operation with the ASCII will begin under control of the ASCII generated internal DMA request. The ASCII receiver or transmitter being used for DMA must be initialized to allow the first DMA transfer to begin. The ASCII receiver must be 'empty' as shown by RDRF = 0. The ASCII transmitter must be 'full' as shown by TDRE = 0. Thus, the first byte should be written to the ASCII Transmit Data Register under program control. The remaining bytes will be transferred using DMA.

**(4) Channel 1 DMA**

DMAC Channel 1 can perform memory ↔ I/O transfers. Except for different registers and status/control bits, operation is exactly the same as described for channel 0 memory ↔ I/O DMA.

To initiate DMA channel 1 memory ↔ I/O transfer perform the following operations.

- ① Load the memory address (19 bits) into MAR1.
- ② Load the I/O address (16 bits) into IAR1.
- ③ Program the source/destination and address increment/decrement mode using the DIM1 and DIM0 bits in DCNTL.
- ④ Specify whether DREQ<sub>1</sub> is level or edge sense in the DMS1 bit

in DCNTL.

- ⑤ Enable or disable DMA termination interrupt with the DIE1 bit in DSTAT.
- ⑥ Program DE1 = 1 (with DWE1 = 0 in the same access) in DSTAT and the DMA operation with the external I/O device will begin using the external DREQ<sub>1</sub> input and TEND<sub>1</sub> output.

**10.4 DMA Bus Timing**

When memory (and memory mapped I/O) is specified as a source or destination, ME goes LOW during the memory access. When I/O is specified as a source or destination, IOE goes LOW during the I/O access.

When I/O (and memory mapped I/O) is specified as a source or destination, the DMA timing is controlled by the external DREQ input and the TEND output indicates DMA termination. Note that external I/O devices may not overlap addresses with internal I/O and control registers, even using DMA.

For I/O accesses, 1 wait state is automatically inserted. Additional wait states can be inserted by programming the on-chip wait state generator or using the external WAIT input. Note that for memory mapped I/O accesses, this automatic I/O wait state is not inserted.

For memory to memory transfers (channel 0 only), the external DREQ<sub>0</sub> input is ignored. Automatic DMA timing is programmed as either burst or cycle steal.

When a DMA memory address carry/borrow between bits A<sub>15</sub> and A<sub>16</sub> of the address bus occurs (when crossing 64k bytes boundaries), the minimum bus cycle is extended to four clocks by automatic insertion of one internal T1 state.

**10.5 DMAC Channel Priority**

For simultaneous DREQ<sub>0</sub> and DREQ<sub>1</sub> requests, channel 0 has priority over channel 1. When channel 0 is performing a memory ↔ memory transfer, channel 1 cannot operate until the channel 0 operation has terminated. If channel 1 is operating, channel 0 cannot operate until channel 1 releases control of the bus.

**10.6 DMAC and BUSREQ, BUSACK**

The BUSREQ and BUSACK inputs allow another bus master to take control of the HD64180 bus. BUSREQ and BUSACK have priority over the on-chip DMAC and will suspend DMAC operation. The DMAC releases the bus to the external bus master at the breakpoint of the DMAC memory or I/O access. Since a single byte DMAC transfer requires a read and a write cycle, it is possible for the DMAC to be suspended after the DMAC read, but before the DMAC write. Even in this case, when the external master releases the HD64180 bus (BUSREQ HIGH), the on-chip DMAC will correctly continue the suspended DMA operation.

**10.7 DMAC Internal Interrupts**

Fig. 45 illustrates the internal DMA interrupt generation circuit.

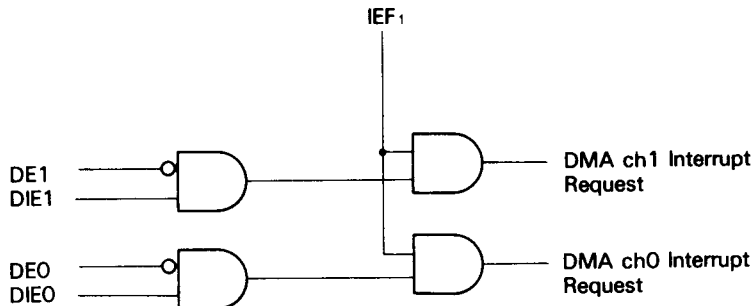

Figure 45 DMAC Interrupt Request Circuit Diagram



DE0 and DE1 are automatically cleared to 0 by the HD64180 at the completion (byte count = 0) of a DMA operation for channel 0 and channel 1 respectively. They remain 0 until a 1 is written. Since DE0 and DE1 use level sense, an interrupt will occur if the CPU IEF<sub>1</sub> flag is set to 1. Therefore, the DMA termination interrupt service routine should disable further DMA interrupts (by programming the channel DIE bit = 0) before enabling CPU interrupts (i.e. IEF<sub>1</sub> is set to 1). After reloading the DMAC address and count registers, the DIE bit can be set to 1 to reenble the channel interrupt, and at the same time DMA can resume by programming the channel DE bit = 1.

**10.8 DMAC and  $\overline{\text{NMI}}$**

$\overline{\text{NMI}}$ , unlike all other interrupts, automatically disables DMAC operation by clearing the DME bit of DSTAT. Thus, the  $\overline{\text{NMI}}$  interrupt service routine may respond to time critical events without delay due to DMAC bus usage. Also,  $\overline{\text{NMI}}$  can be effectively used as an external DMA abort input, recognizing that both channels are suspended by the clearing of DME.

If the falling edge of  $\overline{\text{NMI}}$  occurs before the falling clock of the state prior to T<sub>3</sub> (T<sub>2</sub> or T<sub>w</sub>) of the DMA write cycle, the DMAC will be suspended and the CPU will start the  $\overline{\text{NMI}}$  response at the end of the current cycle.

By setting a channels DE bit to 1, that channels operation can be restarted, and DMA will correctly resume from the point at which it was suspended by  $\overline{\text{NMI}}$ . See Fig. 46 for details.

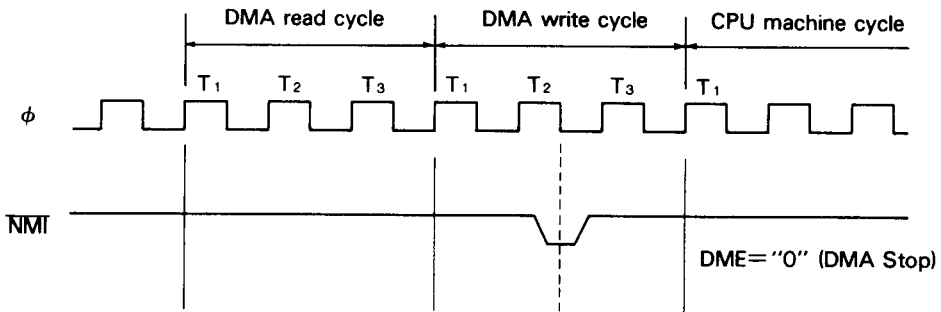

Figure 46  $\overline{\text{NMI}}$  and DMA Operation

**10.9 DMAC and RESET**

During RESET the bits in DSTAT, DMODE, and DCNTL are initialized as stated in their individual register descriptions. Any DMA operation in progress is stopped allowing the CPU to use the

bus to perform the RESET sequence. However, the address register (SAR0, DAR0, MAR1, IAR1) and byte count register (BCR0, BCR1) contents are not changed during RESET.

**11 ASYNCHRONOUS SERIAL COMMUNICATION INTERFACE (ASCI)**

The HD64180 on-chip ASCI has two independent full duplex channels. Based on full programmability of the following functions, the ASCI can directly communicate with a wide variety of standard UARTs (Universal Asynchronous Receiver/Transmitter) including the HD6350 CMOS ACIA and the Serial Communication Interface (SCI) contained on the HD6301 series CMOS single chip controllers.

The key functions for ASCI are shown below. Each channel is independently programmable.

- Full duplex communication
- 7- or 8-bit data length
- Program controlled 9th data bit for multiprocessor communication

- 1 or 2 stop bits
- Odd, even, no parity
- Parity, overrun, framing error detection
- Programmable baud rate generator, /16 and /64 modes  
Speed to 38.4k bits per second (CPU  $f_C = 6.144 \text{ MHz}$ )
- Modem control signals – Channel 0 has  $\overline{\text{DCD}}$ ,  $\overline{\text{CTS}}$  and  $\overline{\text{RTS}}$ , Channel 1 has  $\overline{\text{CTS}}$
- Programmable interrupt condition enable and disable
- Operation with on-chip DMAC

**11.1 ASCI Block Diagram**

Fig. 47 shows the ASCI Block Diagram.

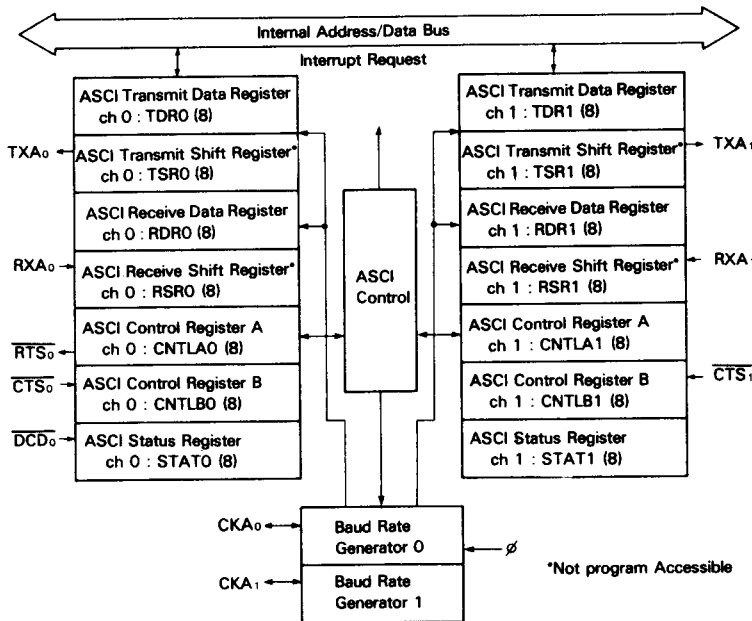

Figure 47 ASCI Block Diagram

**11.2 ASCI Register Description**

**(1) ASCI Transmit Shift Register 0, 1 (TSRO, 1)**

When the ASCI Transmit Shift Register receives data from the ASCI Transmit Data Register (TDR), the data is shifted out to the TXA pin. When transmission is completed, the next byte (if available) is automatically loaded from TDR into TSR and the next transmission starts. If no data is available for transmission, TSR idles by outputting a continuous HIGH level. This register is not program accessible.

**(2) ASCI Transmit Data Register 0, 1 (TDRO, 1: I/O Address = 06H, 07H)**

Data written to the ASCI Transmit Data Register is transferred to the TSR as soon as TSR is empty. Data can be written while TSR is shifting out the previous byte of data. Thus, the ASCI transmitter is double buffered.

Data can be written into and read from the ASCI Transmit Data Register.

If data is read from the ASCI Transmit Data Register, the ASCI

data transmit operation won't be affected by this read operation.

**(3) ASCI Receive Shift Register 0, 1 (RSRO, 1)**

This register receives data shifted in on the RXA pin. When full, data is automatically transferred to the ASCI Receive Data Register (RDR) if it is empty. If RSR is not empty when the next incoming data byte is shifted in, an overrun error occurs. This register is not program accessible.

**(4) ASCI Receive Data Register 0, 1 (RDRO, 1: I/O Address = 08H, 09H)**

When a complete incoming data byte is assembled in RSR, it is automatically transferred to the RDR if RDR is empty. The next incoming data byte can be shifted into RSR while RDR contains the previous received data byte. Thus, the ASCI receiver is double buffered.

The ASCI Receive Data Register is read-only-register.

However, if RDRF = 0, data can be written into the ASCI Receive Data Register, and the data can be read.

# HD64180R/Z

## (5) ASCII Status Register 0 (STAT0, 1)

Each channel status register allows interrogation of ASCII communication, error and modem control signal status as well as enabling and disabling of ASCII interrupts.

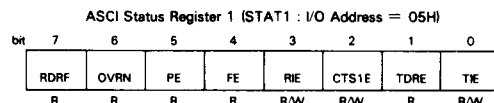
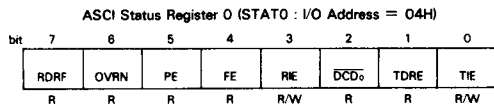

### RDRF: Receive Data Register Full (bit 7)

RDRF is set to 1 when an incoming data byte is loaded into RDR. Note that if a framing or parity error occurs, RDRF is still set and the receive data (which generated the error) is still loaded into RDR. RDRF is cleared to 0 by reading RDR, when the DCD<sub>0</sub> input is HIGH, in IOSTOP mode and during RESET.

### OVRN: Overrun Error (bit 6)

OVRN is set to 1 when RDR is full and RSR becomes full. OVRN is cleared to 0 when the EFR bit (Error Flag Reset) of CNTLA is written to 0, when DCD<sub>0</sub> is HIGH, in IOSTOP mode and during RESET.

### PE: Parity Error (bit 5)

PE is set to 1 when a parity error is detected on an incoming data byte and ASCII parity detection is enabled (the MOD1 bit of CNTLA is set to 1). PE is cleared to 0 when the EFR bit (Error Flag Reset) of CNTLA is written to 0, when DCD<sub>0</sub> is HIGH, in IOSTOP mode and during RESET.

### FE: Framing Error (bit 4)

If a receive data byte frame is delimited by an invalid stop bit (i.e. 0, should be 1), FE is set to 1. FE is cleared to 0 when the EFR bit (Error Flag Reset) of CNTLA is written to 0, when DCD<sub>0</sub> is HIGH, in IOSTOP mode and during RESET.

### RIE: Receive Interrupt Enable (bit 3)

RIE should be set to 1 to enable ASCII receive interrupt requests. When RIE to 1, if any of the flags RDRF, OVRN, PE, FE become set to 1 an interrupt request is generated. For channel 0, an interrupt will also be generated by the transition of the external DCD<sub>0</sub> input from LOW to HIGH. RIE is cleared to 0 during RESET.

### DCD<sub>0</sub>: Data Carrier Detect (bit 2 STAT0)

Channel 0 has an external DCD<sub>0</sub> input pin. The DCD<sub>0</sub> bit is set to 1 when the DCD<sub>0</sub> input is HIGH. It is cleared to 0 on the first read of STAT0 following the HIGH to LOW transition of DCD<sub>0</sub> input and during RESET. When DCD<sub>0</sub> = 1, receiver unit is reset and receiver operation is inhibited.

### CTS1E: Channel 1 CTS Enable (bit 2 STAT1)

Channel 1 has an external CTS<sub>1</sub> input which is multiplexed with the receive data pin (RXS) for the CSI/O (Clocked Serial I/O Port). Setting CTS1E to 1 selects the CTS<sub>1</sub> function and clearing CTS1E to 0 selects the RXS function.

### TDRE: Transmit Data Register Empty (bit 1)

TDRE = 1 indicates that the TDR is empty and the next transmit data byte can be written to TDR. After the byte is written to TDR, TDRE is cleared to 0 until the ASCII transfers the byte from the TDR to the TSR, at which time TDRE is again set to 1. TDRE

is set to 1 in IOSTOP mode and during RESET. When the external CTS input is HIGH, TDRE is reset to 0.

### TIE: Transmit Interrupt Enable (bit 0)

TIE should be set to 1 to enable ASCII transmit interrupt requests. If TIE = 1, an interrupt will be requested when TDRE = 1. TIE is cleared to 0 during RESET.

## ASCII Control Register A0, 1 (CNTLA0, 1)

Each ASCII channel Control Register A configures the major operating modes such as receiver/transmitter enable and disable, data format, and multiprocessor communication mode.

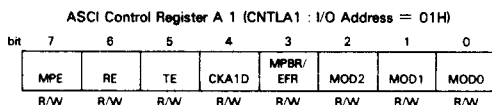
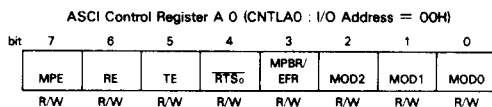

### MPE: Multi Processor Mode Enable (bit 7)

The ASCII has a multiprocessor communication mode which utilizes an extra data bit for selective communication when a number of processors share a common serial bus. Multiprocessor data format is selected when the MP bit in CNTLB is set to 1. If multiprocessor mode is not selected (MP bit in CNTLB = 0), MPE has no effect. If multiprocessor mode is selected, MPE enables or disables the 'wake-up' feature as follows. If MPE is set to 1, only received bytes in which the MPB (multiprocessor bit) = 1 can affect the RDRF and error flags. Effectively, other bytes (with MPB = 0) are 'ignored' by the ASCII. If MPE is reset to 0, all bytes, regardless of the state of the MPB data bit, affect the RDRF and error flags. MPE is cleared to 0 during RESET.

### RE: Receiver Enable (bit 6)

When RE is set to 1, the ASCII receiver is enabled. When RE is cleared to 0, the receiver is disabled and any receive operation in progress is interrupted. However, the RDRF and error flags are not reset and the previous contents of RDRF and error flags are held. RE is cleared to 0 in IOSTOP mode and during RESET.

### TE: Transmitter Enable (bit 5)

When TE is set to 1, the ASCII transmitter is enabled. When TE is cleared to 0, the transmitter is disabled and any transmit operation in progress is interrupted. However, the TDRE flag is not reset and the previous contents of TDRE are held. TE is cleared to 0 in IOSTOP mode and during RESET.

### RTS<sub>0</sub> - Request to Send Channel 0 (bit 4 in CNTLA0)

When RTS<sub>0</sub> is cleared to 0, the RTS<sub>0</sub> output pin will go LOW. When RTS<sub>0</sub> is set to 1, the RTS<sub>0</sub> output immediately goes HIGH. RTS<sub>0</sub> is set to 1 during RESET.

### CKA1D: CKA1 Clock Disable (bit 4 in CNTLA1)

When CKA1D is set to 1, the multiplexed CKA1/TEND<sub>0</sub> pin is used for the TEND<sub>0</sub> function. When CKA1D = 0, the pin is used as CKA1, an external data clock input/output for channel 1. CKA1D is cleared to 0 during RESET.

### MPBR/EFR: Multiprocessor Bit Receive/Error Flag Reset (bit 3)

When multiprocessor mode is enabled (MP in CNTLB = 1), MPBR, when read, contains the value of the MPB bit for the last re-

ceive operation. When written to 0, the EFR function is selected to reset all error flags (OVRN, FE and PE) to 0. MPBR/EFR is undefined during RESET.

**MOD2, 1, 0: ASCII Data Format Mode 2, 1, 0 (bits 2-0)**

These bits program the ASCII data format as follows.

- MOD2
  - = 0 → 7 bit data
  - = 1 → 8 bit data
- MOD1
  - = 0 → No parity
  - = 1 → Parity enabled
- MOD0
  - = 0 → 1 stop bit
  - = 1 → 2 stop bits

The data formats available based on all combinations of MOD2, MOD1 and MOD0 are shown in Table 10.

Table 10 Combination of Data Format

MOD2	MOD1	MOD0	Data Format
0	0	0	Start+7 bit data+1 stop
0	0	1	Start+7 bit data+2 stop
0	1	0	Start+7 bit data+parity+1 stop
0	1	1	Start+7 bit data+parity+2 stop
1	0	0	Start+8 bit data+1 stop
1	0	1	Start+8 bit data+2 stop
1	1	0	Start+8 bit data+parity+1 stop
1	1	1	Start+8 bit data+parity+2 stop

**(6) ASCII Control Register B0, 1 (CNTLB0, 1)**

Each ASCII channel control register B configures multiprocessor mode, parity and baud rate selection.

ASCII Control Register B 0 (CNTLB0 : I/O Address = 02H)  
 ASCII Control Register B 1 (CNTLB1 : I/O Address = 03H)

bit	7	6	5	4	3	2	1	0
	MPBT	MP	CTS/PS	PEO	DR	SS2	SS1	SS0
	R/W	R/W	R/W	R/W	R/W	R/W	R/W	R/W

**MPBT: Multiprocessor Bit Transmit (bit 7)**

When multiprocessor communication format is selected (MP bit = 1), MPBT is used to specify the MPB data bit for transmission. If MPBT = 1, then MPB = 1 is transmitted. If MPBT = 0, then MPB = 0 is transmitted. MPBT state is undefined during and after RESET.

**MP: Multiprocessor Mode (bit 6)**

When MP is set to 1, the data format is configured for multiprocessor mode based on the MOD2 (number of data bits) and MOD0 (number of stop bits) bits in CNTLA. The format is as follows.

Start bit + 7 or 8 data bits + MPB bit + 1 or 2 stop bits

Note that multiprocessor (MP = 1) format has no provision for parity. If MP = 0, the data format is based on MOD0, MOD1 and MOD2 and may include parity. The MP bit is cleared to 0 during RESET.

**CTS/PS: Clear to Send/Prescale (bit 5)**

When read, CTS/PS reflects the state of the external CTS input. If the CTS input pin is HIGH, CTS/PS will be read as 1. Note that when the CTS input pin is HIGH, the TDRE bit is inhibited (i.e. held at 0). For channel 1, the CTS<sub>1</sub> input is multiplexed with RXS pin (Clocked Serial Receive Data). Thus, CTS/PS is only valid when read if the channel 1 CTS1E bit = 1 and the CTS<sub>1</sub> input pin function is selected. The read data of CTS/PS is not affected by RESET.

When written, CTS/PS specifies the baud rate generator prescale factor. If CTS/PS is set to 1, the system clock ( $\phi$ ) is prescaled by 30 while if CTS/PS is cleared to 0, the system clock is prescaled by 10. CTS/PS is cleared to 0 during RESET.

**PEO: Parity Even Odd (bit 4)**

PEO selects even or odd parity. PEO does not affect the enabling/disabling of parity (MOD1 bit of CNTLA). If PEO is cleared to 0, even parity is selected. If PEO is set to 1, odd parity is selected. PEO is cleared to 0 during RESET.

**DR: Divide Ratio (bit 3)**

DR specifies the divider used to obtain baud rate from the data sampling clock. If DR is cleared to 0, divide by 16 is used while if DR is set to 1, divide by 64 is used. DR is cleared to 0 during RESET.

**SS2, 1, 0: Source/Speed Select 2, 1, 0 (bits 2-0)**

Specify the data clock source (internal or external) and baud rate prescale factor. SS2, SS1, and SS0 are all set to 1 during RESET. Table 11 shows the divide ratio corresponding to SS2, SS1, and SS0.

Table 11 Divide Ratio

SS2	SS1	SS0	Divide Ratio
0	0	0	+1
0	0	1	+2
0	1	0	+4
0	1	1	+8
1	0	0	+16
1	0	1	+32
1	1	0	+64
1	1	1	external clock

The external ASCII channel 0 data clock pins are multiplexed with DMA control lines (CKA<sub>0</sub>/DREQ<sub>0</sub> and CKA<sub>1</sub>/TEND<sub>0</sub>). During RESET, these pins are initialized as ASCII data clock inputs. If SS2, SS1, and SS0 are reprogrammed (any other value than SS2, SS1, SS0 = 1) these pins become ASCII data clock outputs. However, if DMAC channel 0 is configured to perform memory ↔ I/O (and memory mapped I/O) transfers the CKA<sub>0</sub>/DREQ<sub>0</sub> pin revert to DMA control signals regardless of SS2, SS1, and SS0 programming. Also, if the CKA1D bit in the CNTLA register is set to 1, then the CKA<sub>1</sub>/TEND<sub>0</sub> reverts to the DMA Control output function regardless of SS2, SS1, and SS0 programming.

Final data clock rates are based on CTS/PS (prescale), DR, SS2, SS1, SS0, and the HD64180 system clock ( $\phi$ ) frequency as shown in Table 12.

Table 12 Baud Rate List

Prescaler		Sampling Rate		Baud Rate				General Divide Ratio	Baud Rate (Example) (BPS)			CKA	
PS	Divide Ratio	DR	Rate	SS2	SS1	SS0	Divide Ratio		$\phi=6.144$ MHz	$\phi=4.608$ MHz	$\phi=3.072$ MHz	I/O	Clock Frequency
0	$\phi \div 10$	0	16	0	0	0	$\div 1$	$\phi \div 160$	38400		19200	0	$\phi \div 10$
				0	0	1	2	320	19200	9600	20		
				0	1	0	4	640	9600	4800	40		
				0	1	1	8	1280	4800	2400	80		
				1	0	0	16	2560	2400	1200	160		
				1	0	1	32	5120	1200	600	320		
				1	1	0	64	10240	600	300	640		
		1	1	1	—	$fc \div 16$	—	—	fc				
		1	64	0	0	0	$\div 1$	$\phi \div 640$	9600		4800	0	$\phi \div 10$
				0	0	1	2	1280	4800	2400	20		
				0	1	0	4	2560	2400	1200	40		
				0	1	1	8	5120	1200	600	80		
				1	0	0	16	10240	600	300	160		
				1	0	1	32	20480	300	150	320		
1	1			0	64	40960	150	75	640				
1	1	1	—	$fc \div 64$	—	—	fc						
1	$\phi \div 30$	0	16	0	0	0	$\div 1$	$\phi \div 480$		9600	0	$\phi \div 30$	
				0	0	1	2	960	4800	4800		60	
				0	1	0	4	1920	2400	2400		120	
				0	1	1	8	3840	1200	1200		240	
				1	0	0	16	7680	600	600		480	
				1	0	1	32	15360	300	300		960	
				1	1	0	64	30720	150	150		1920	
		1	1	1	—	$fc \div 16$	—	—	fc				
		1	64	0	0	0	$\div 1$	$\phi \div 1920$		2400		0	$\phi \div 30$
				0	0	1	2	3840	1200	1200	60		
				0	1	0	4	7680	600	600	120		
				0	1	1	8	15360	300	300	240		
				1	0	0	16	30720	150	150	480		
				1	0	1	32	61440	75	75	960		
1	1			0	64	122880	37.5	37.5	1920				
1	1	1	—	$fc \div 64$	—	—	fc						

**11.3 MODEM Control Signals**

ASCII channel 0 has  $\overline{CTS}_0$ ,  $\overline{DCD}_0$ , and  $\overline{RTS}_0$  external modem control signals. ASCII channel 1 has a  $\overline{CTS}_1$  modem control signal which is multiplexed with RXS pin (Clocked Serial Receive Data).

**(1)  $\overline{CTS}_0$ : Clear to Send 0 (input)**

The  $\overline{CTS}_0$  input allows external control (start/stop) of ASCII channel 0 transmit operations. When  $\overline{CTS}_0$  is HIGH, channel 0 TDRE bit is held at 0 regardless of whether the TDR0 (Transmit Data Register) is full or empty. When  $\overline{CTS}_0$  is LOW, TDRE will reflect the state of TDR0. Note that the actual transmit operation is not disabled by  $\overline{CTS}_0$  HIGH, only TDRE is inhibited.

**(2)  $\overline{DCD}_0$ : Data Carrier Detect 0 (input)**

The  $\overline{DCD}_0$  input allows external control (start/stop) of ASCII channel 0 receive operations. When  $\overline{DCD}_0$  is HIGH, channel 0 RDRF bit is held at 0 regardless of whether the RDR0 (Receive Data Register) is full or empty. The error flags (PE, FE and OVRN bits) are also held at 0. Even after the  $\overline{DCD}_0$  input goes LOW, these

bits will not resume normal operation until the status register (STAT0) is read. Note that this first read of STAT0, while enabling normal operation, will still indicate the  $\overline{DCD}_0$  input is HIGH ( $\overline{DCD}_0$  bit = 1) even though it has gone LOW. Thus, the STAT0 register should be read twice to insure the  $\overline{DCD}_0$  bit is cleared to 0.

**(3)  $\overline{RTS}_0$ : Request to Send 0 (output)**

$\overline{RTS}_0$  allows the ASCII to control (start/stop) another communication devices transmission (for example, by connection to that devices  $\overline{CTS}$  input).  $\overline{RTS}_0$  is essentially a 1 bit output port, having no side effects on other ASCII registers or flags.

**(4)  $\overline{CTS}_1$ : Clear to Send 1 (input)**

Channel 1  $\overline{CTS}_1$  input is multiplexed with the RXS pin (Clocked Serial Receive Data). The  $\overline{CTS}_1$  function is selected when the CTS1E bit in STAT1 is set to 1. When enabled, the  $\overline{CTS}_1$  operation is equivalent to  $\overline{CTS}_0$ .

Modem control signal timing is shown in Fig. 48 (a) and Fig. 48 (b).

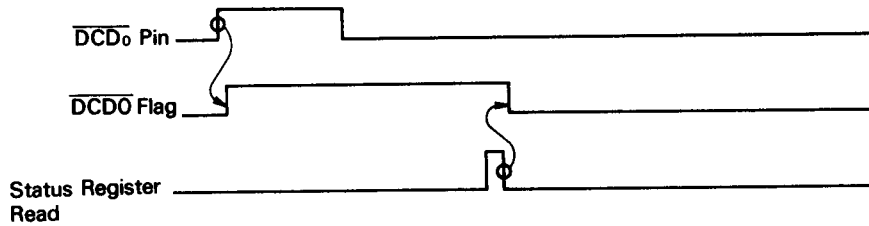

Figure 48 (a)  $\overline{DCD0}$  Timing

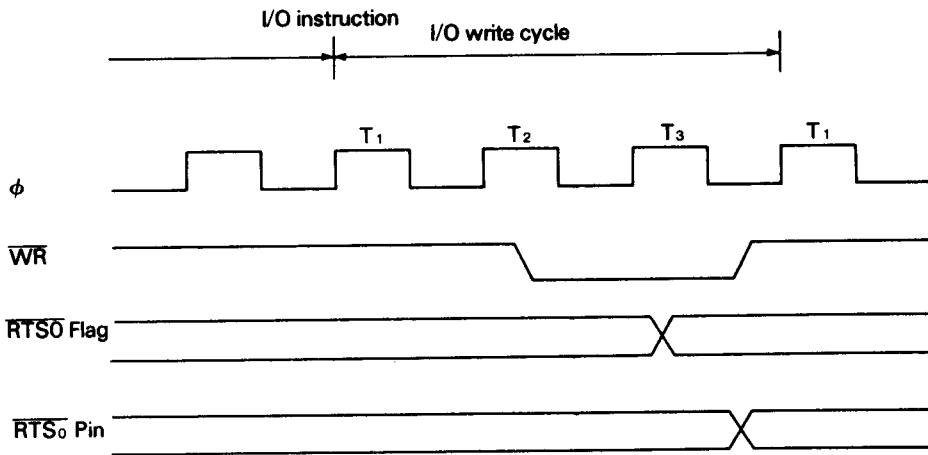

Figure 48 (b)  $\overline{RTS0}$  Timing

11.4 ASCII Interrupts

Fig. 49 shows the ASCII interrupt request generation circuit.

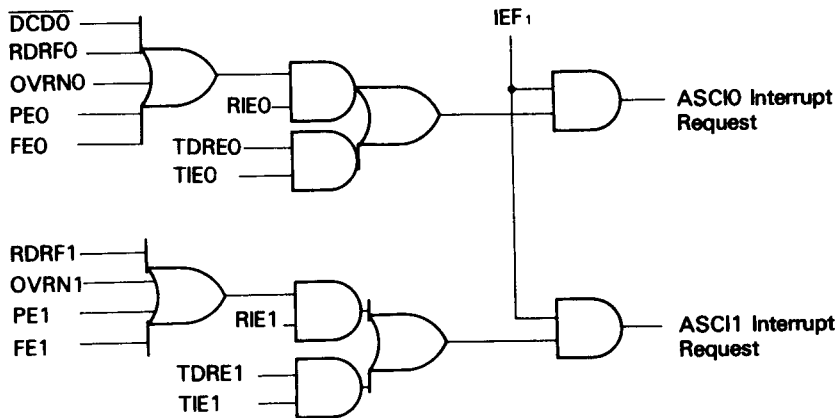

Figure 49 ASCII Interrupt Request Circuit Diagram

# HD64180R/Z

## 11.5 ASCII ↔ DMAC operation

Operation of the ASCII with the on-chip DMAC channel 0 requires the DMAC be correctly configured to utilize the ASCII flags as DMA request signals.

## 11.6 ASCII and RESET

During RESET, the ASCII status and control registers are initialized as defined in the individual register descriptions.

Receive and Transmit operations are stopped during RESET. However, the contents of the transmit and receive data registers (TDR and RDR) are not changed by RESET.

## 11.7 ASCII Clock

In external clock input mode, the external clock is directly input to the sampling rate ( $\div 16/\div 64$ ) as shown in Fig. 50.

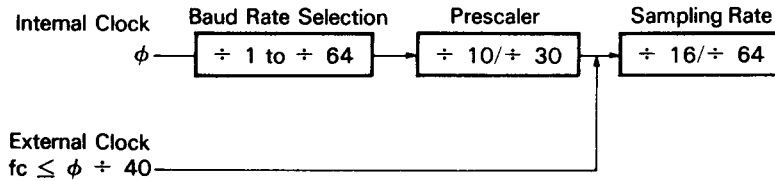

Figure 50 ASCII Clock Block Diagram

## 12 CLOCKED SERIAL I/O PORT (CSI/O)

The HD64180 includes a simple, high speed clock synchronous serial I/O port. The CSI/O includes transmit/receive (half duplex), fixed 8-bit data and internal or external data clock selection. High speed operation (baud rate as high as 200k bits/second at  $f_c = 4$  MHz) is provided. The CSI/O is ideal for implementing a multiprocessor communication link between the HD64180 and the HMCS400 series (4-bit) and the HD6301 series (8-bit) single chip

controllers as well as additional HD64180s. These secondary devices may typically perform a portion of the system I/O processing such as keyboard scan/decode, LDC interface etc.

### 12.1 CSI/O Block Diagram

The CSI/O block diagram is shown in Fig. 51. The CSI/O consists of two registers – the Transmit/Receive Data Register (TRDR) and Control Register (CNTR).

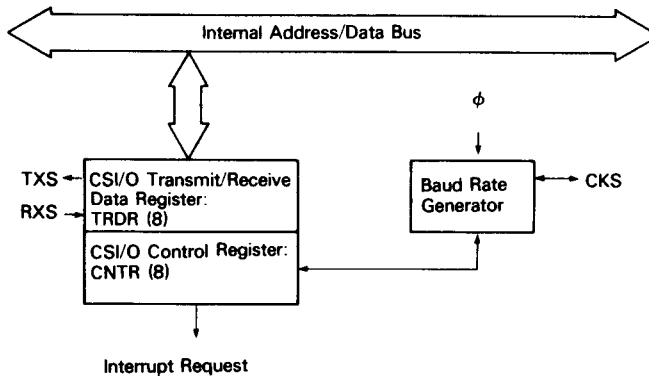

Figure 51 CSI/O Block Diagram

### 12.2 CSI/O Register Description

#### (1) CSI/O Transmit/Receive Data Register (TRDR: I/O Address = 0BH)

TRDR is used for both CSI/O transmission and reception. Thus, the system design must insure that the constraints of half-duplex operation are met (Transmit and receive operation can't occur simultaneously). For example, if a CSI/O transmission is attempted at the same time that the CSI/O is receiving data, a CSI/O will not work. Also note that TRDR is not buffered. Therefore, attempting to perform a CSI/O transmit while the previous transmit data is still being shifted out causes the shift data to be immediately updated, thereby corrupting the transmit operation in progress. Similarly, reading TRDR while a transmit or receive is in progress should be avoided.

#### (2) CSI/O Control/Status Register (CNTR: I/O Address = 0AH)

CNTR is used to monitor CSI/O status, enable and disable the CSI/O, enable and disable interrupt generation and select the data clock speed and source.

CSI/O Control Register (CNTR : I/O Address = 0AH)								
bit	7	6	5	4	3	2	1	0
	EF	EE	RE	TE	–	SS2	SS1	SS0
	R	R/W	R/W	R/W		R/W	R/W	R/W

#### EF: End Flag (bit 7)

EF is set to 1 by the CSI/O to indicate completion of an 8-bit data transmit or receive operation. If EIE (End Interrupt Enable)



bit = 1 during the time EF = 1, a CPU interrupt request will be generated. Program access of TRDR should only occur if EF = 1. The CSI/O clears EF to 0 when TRDR is read or written. EF is cleared to 0 during RESET and IOSTOP mode.

**EIE: End Interrupt Enable (bit 6)**

EIE should be set to 1 to enable EF = 1 to generate a CPU interrupt request. The interrupt request is inhibited if EIE is cleared to 0. EIE is cleared to 0 during RESET.

**RE: Receive Enable (bit 5)**

A CSI/O receive operation is started by setting RE to 1. When RE is set to 1, the data clock is enabled. In internal clock mode, the data clock is output from the CKS pin. In external clock mode, the clock is input on the CKS pin. In either case, data is shifted in on the RXS pin in synchronization with the (internal or external) data clock. After receiving 8 bits of data, the CSI/O automatically clears RE to 0, EF is set to 1 and an interrupt (if enabled by EIE = 1) will be generated. Note that RE and TE should never both be set to 1 at the same time. RE is cleared to 0 during RESET and IOSTOP mode.

Note that the RXS pin (pin 52) is multiplexed with  $\overline{CTS}$ , modem control input of ASCII channel 1. In order to enable the RXS function, the CTSIE bit in CNTA1 should be reset to 0.

**TE: Transmit Enable (bit 4)**

A CSI/O transmit operation is started by setting TE to 1. When TE is set to 1, the data clock is enabled. In internal clock mode, the data clock is output from the CKS pin. In external clock mode, the clock is input on the CKS pin. In either case, data is shifted out on the TXS pin synchronous with the (internal or external) data clock. After transmitting 8 bits of data, the CSI/O automatically clears TE

to 0, EF is set to 1 and an interrupt (if enabled by EIE = 1) will be generated. Note that TE and RE should never both be set to 1 at the same time. TE is cleared to 0 during RESET and IOSTOP mode.

**SS2, 1, 0: Speed Select 2, 1, 0 (bits 2-0)**

SS2, SS1 and SS0 select the CSI/O transmit/receive clock source and speed. SS2, SS1 and SS0 are all set to 1 during RESET. Table 13 shows CSI/O Baud Rate Selection.

Table 13 CSI/O Baud Rate Selection

SS2	SS1	SS0	Divide Ratio	Baud Rate
0	0	0	+ 20	(200000)
0	0	1	+ 40	(100000)
0	1	0	+ 80	(50000)
0	1	1	+ 160	(25000)
1	0	0	+ 320	(12500)
1	0	1	+ 640	(6250)
1	1	0	+ 1280	(3125)
1	1	1	external Clock input (less than + 20)	

( ) shows the baud rate (BPS) at  $\phi = 4$  MHz.

After RESET, the CKS pin is configured as an external clock input (SS2, SS1, SS0 = 1). Changing these values causes CKS to become an output pin and the selected clock will be output when transmit or receive operations are enabled.

**12.3 CSI/O Interrupts**

The CSI/O interrupt request circuit is shown in Fig. 52.

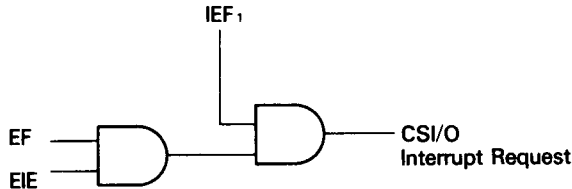

Figure 52 CSI/O Interrupt Circuit Diagram

**12.4 CSI/O Operation**

The CSI/O can be operated using status polling or interrupt driven algorithms.

**(1) Transmit – Polling**

- ① Poll the TE bit in CNTR until TE = 0.
- ② Write the transmit data into TRDR.
- ③ Set the TE bit in CNTR to 1.
- ④ Repeat 1 to 3 for each transmit data byte.

**(2) Transmit – Interrupts**

- ① Poll the TE bit in CNTR until TE = 0.
- ② Write the first transmit data byte into TRDR.
- ③ Set the TE and EIE bits in CNTR to 1.
- ④ When the transmit interrupt occurs, write the next transmit data byte into TRDR.
- ⑤ Set the TE bit in CNTR to 1.
- ⑥ Repeat 4 to 5 for each transmit data byte.

**(3) Receive – Polling**

- ① Poll the RE bit in CNTR until RE = 0.
- ② Set the RE bit in CNTR to 1.
- ③ Poll the RE bit in CNTR until RE = 0.

- ④ Read the receive data from TRDR.
- ⑤ Repeat 2 to 4 for each receive data byte.

**(4) Receive – Interrupts**

- ① Poll the RE bit in CNTR until RE = 0.
- ② Set the RE and EIE bits in CNTR to 1.
- ③ When the receive interrupt occurs read the receive data from TRDR.
- ④ Set the RE bit in CNTR to 1.
- ⑤ Repeat 3 to 4 for each receive data byte.

**12.5 CSI/O Operation Timing Notes**

- (1) Note that transmitter clocking and receiver sampling timings are different from internal and external clocking modes. Fig. 53 to Fig. 54 shows CSI/O Transmit/Receive Timing.
- (2) The transmitter and receiver should be disabled (TE and RE = 0) when initializing or changing the baud rate.

**12.6 CSI/O Operation Notes**

- (1) Disable the transmitter and receiver (TE and RE = 0) before initializing or changing the baud rate. When changing the baud rate after completion of transmission or reception, a delay of at least one bit time is required before baud rate modification.

# HD64180R/Z

- (2) When RE or TE is cleared to 0 by software, a corresponding receive or transmit operation is immediately terminated. Normally, TE or RE should only be cleared to 0 when EF = 1.
- (3) Simultaneous transmission and reception is not possible. Thus, TE and RE should not both be 1 at the same time.

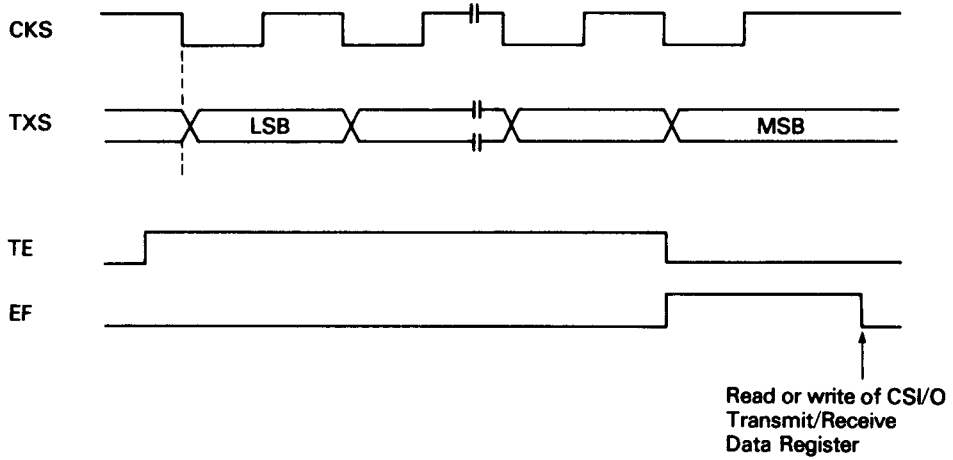

Figure 53 Transmit Timing – Internal Clock

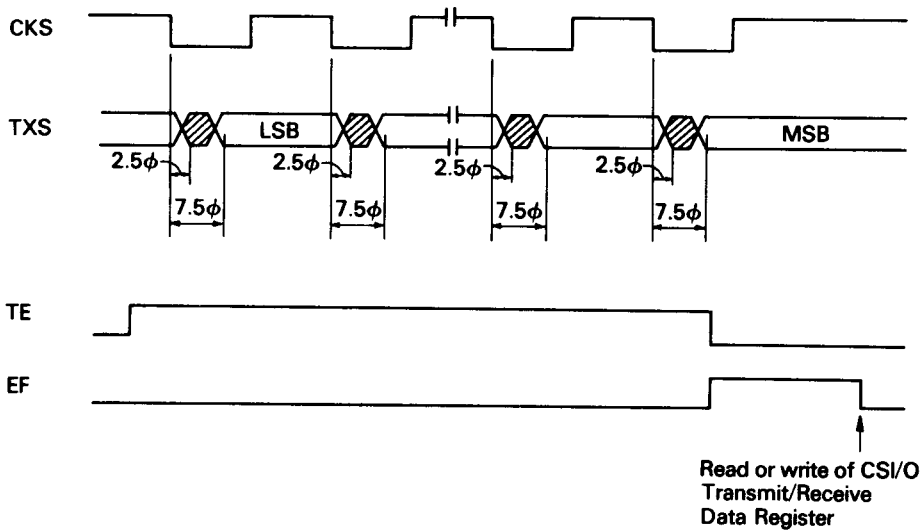

Figure 54 Transmit Timing – External Clock

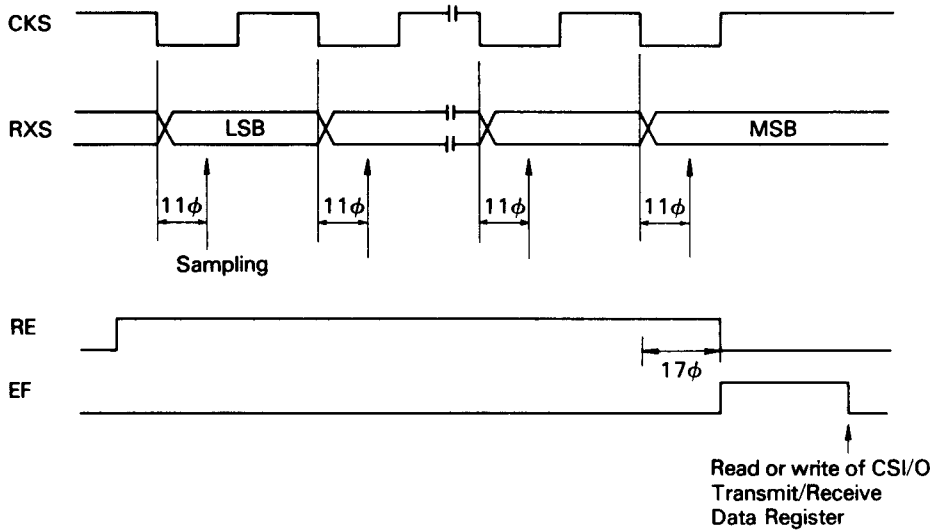

Figure 55 Receive Timing – Internal Clock

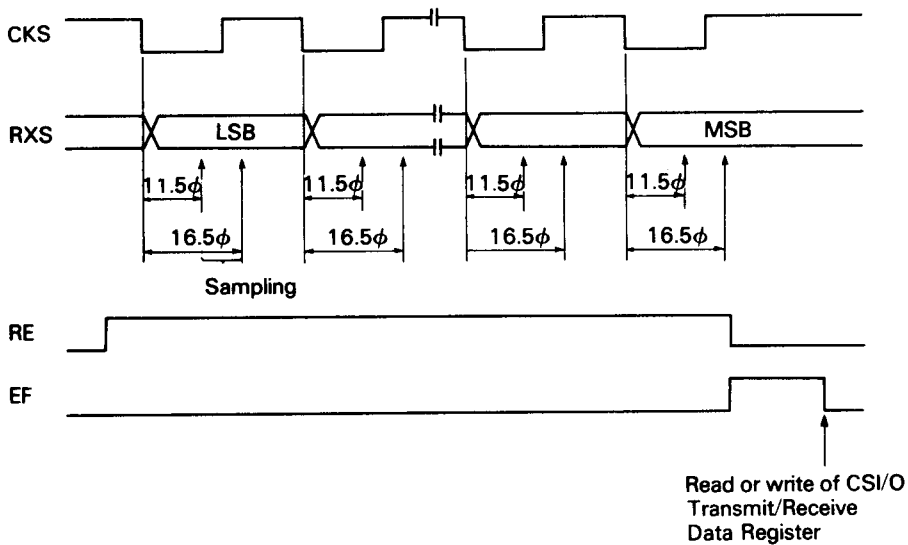

Figure 56 Receive Timing – External Clock

**12.7 CSI/O and RESET**

During RESET each bit in the CNTR is initialized as defined in the CNTR register description.

CSI/O transmit and receive operations in progress are aborted during RESET. However, the contents of TRDR are not changed.

ly enabled or disabled. In addition, PRT channel 1 has a TOUT output pin (multiplexed with  $A_{17}$ ) which can be set HIGH, LOW, or toggled. Thus PRT1 can perform programmable output waveform

have separate timer data and reload registers and a common timer control register. The PRT input clock for both channels is equal to the system clock ( $\phi$ ) divided by 20.

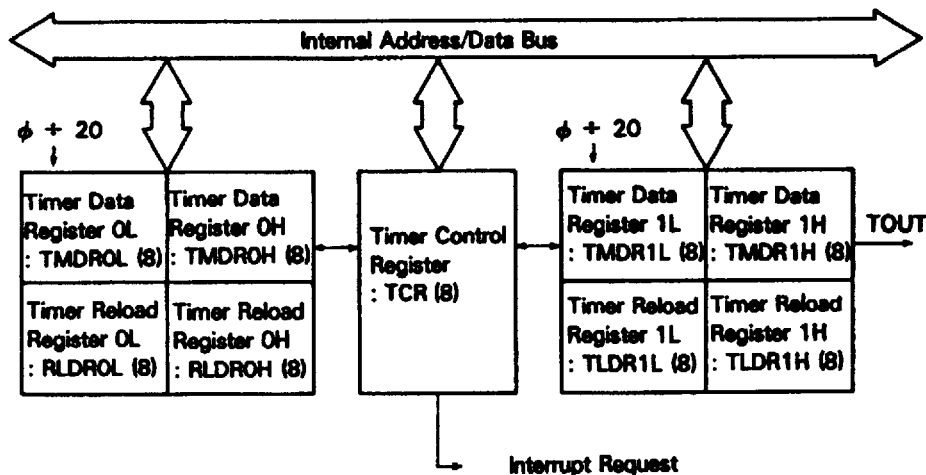

Figure 57 PRT Block Diagram

### 13.2 PRT Register Description

(1) **Timer Data Register (TMDR: I/O Address = CH0: 0DH, 0CH CH1: 16H, 14H)**

PRT0 and PRT1 each have 16-bit Timer Data Registers (TMDR). TMDR0 and TMDR1 are each accessed as low and high byte registers (TMDR0H, TMDROL and TMDR1H, TMDR1L). During RESET, TMDR0 and TMDR1 are set to FFFFH.

TMDR is decremented once every twenty  $\phi$  clocks. When TMDR counts down to 0, it is automatically reloaded with the value contained in the Reload Register (RLDR).

TMDR can be read and written by software using the following procedures. The read procedure uses a PRT internal temporary storage register to return accurate data without requiring the timer to be stopped. The write procedure requires the PRT to be stopped.

For reading (without stopping the timer), TMDR must be read in the order of lower byte — higher byte (TMDRnL, TMDRnH). The lower byte read (TMDRnL) will store the higher byte value in an internal register. The following higher byte read (TMDRnH) will access this internal register. This procedure insures timer data validity by eliminating the problem of potential 16-bit timer updating between each 8-bit read. Specifically, reading TMDR in higher byte — lower byte order may result in invalid data. Note the implications of TMDR higher byte internal storage for applications which may read only the lower and/or higher bytes. In normal operation all TMDR read routines should access both the lower and higher bytes, in that order.

For writing, the TMDR down counting must be inhibited using the TDE (Timer Down Count Enable) bits in the TCR (Timer Control Register), following which any or both higher and lower bytes of TMDR can be freely written (and read) in any order.

(2) **Timer Reload Register (RLDR: I/O Address = CH0: 0EH, 0FH CH1: 16H, 17H)**

PRT0 and PRT1 each have 16-bit Timer Reload Registers (RLDR). RLDR0 and RLDR1 are each accessed as low and high byte registers (RLDR0H, RLDR0L and RLDR1H, RLDR1L). During RESET RLDR0 and RLDR1 are set to FFFFH.

When the TMDR counts down to 0, it is automatically reloaded with the contents of RLDR.

(3) **Timer Control Register (TCR)**

TCR monitors both channels (PRT0, PRT1) TMDR status and controls enabling and disabling of down counting and interrupts as well as controlling the output pin ( $A_{17}$ /TOUT) for PRT 1.

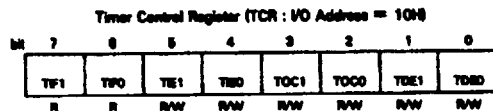

**TIF1: Timer Interrupt Flag 1 (bit 7)**

When TMDR1 decrements to 0, TIF1 is set to 1. This can generate an interrupt request if enabled by TIE1 = 1. TIF1 is reset to 0 when TCR is read and the higher or lower byte of TMDR1 are read. During RESET, TIF1 is cleared to 0.

**TIF0: Timer Interrupt Flag 0 (bit 6)**

When TMDR0 decrements to 0, TIF0 is set to 1. This can generate an interrupt request if enabled by TIE0 = 1. TIF0 is reset to 0 when TCR is read and the higher or lower byte of TMDR0 are read. During RESET, TIF0 is cleared to 0.



**TIE1: Timer Interrupt Enable 1 (bit 5)**

When TIE1 is set to 1, TIF1 = 1 will generate a CPU interrupt request. When TIE1 is reset to 0, the interrupt request is inhibited. During RESET, TIE1 is cleared to 0.

**TIE0: Timer Interrupt Enable 0 (bit 4)**

When TIE0 is set to 1, TIF0 = 1 will generate a CPU interrupt request. When TIE0 is reset to 0, the interrupt request is inhibited. During RESET, TIE0 is cleared to 0.

**TOC1, 0: Timer Output Control (bits 3, 2)**

TOC1 and TOC0 control the output of PRT1 using the multiplexed A<sub>16</sub>/TOUT pin as shown below. During RESET, TOC1 and TOC0 are cleared to 0. This selects the address function for A<sub>16</sub>/TOUT. By programming TOC1 and TOC0, the A<sub>16</sub>/TOUT pin can be forced HIGH, LOW or toggled when TMDR1 decrements to 0.

TOC1	TOC0	OUTPUT	
0	0	inhibited	(A <sub>16</sub> /TOUT pin is selected as an address output function.)
0	1	toggled*	(A <sub>16</sub> /TOUT pin is selected as a PRT1 output function.)
1	0		
1	1		

\* When TMDR1 decrements to 0, TOUT level is reversed. This can provide square wave with 50% duty to external devices without any software support.

**TDE1, 0: Timer Down Count Enable (bits 1, 0)**

TDE1 and TDE0 enable and disable down counting for TMDR1 and TMDR0 respectively. When TDEn (n = 0, 1) is set to 1, down counting is executed for TMDRn. When TDEn is reset to 0, down counting is stopped and TMDRn can be freely read or written. TDE1 and TDE0 are cleared to 0 during RESET and TMDRn will not decrement until TDEn is set to 1.

Fig. 58 shows timer initialization, count down and reload timing. Fig. 59 shows timer output (A<sub>16</sub>/TOUT) timing.

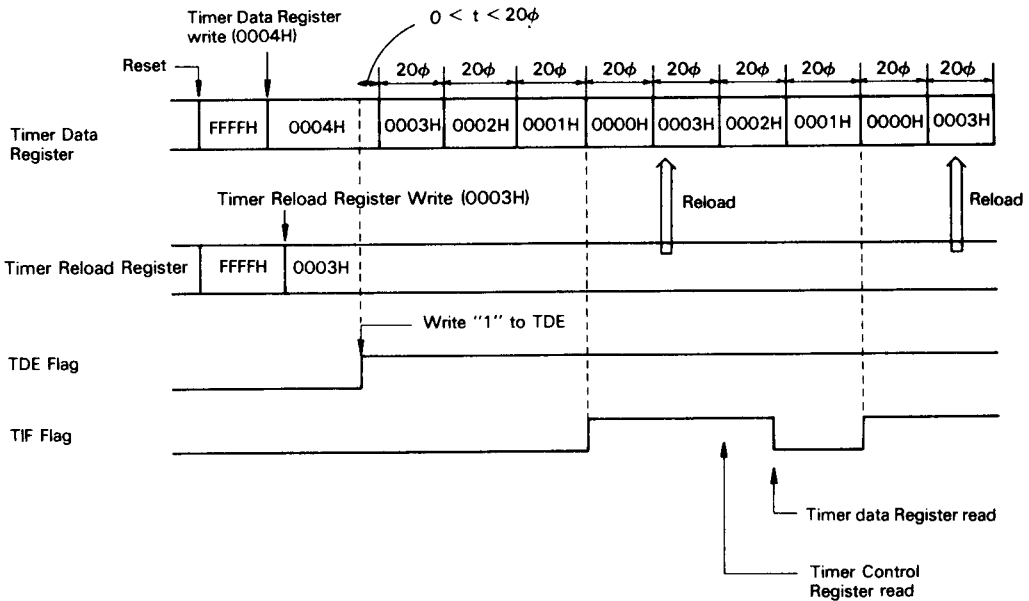

Figure 58 PRT Operation Timing

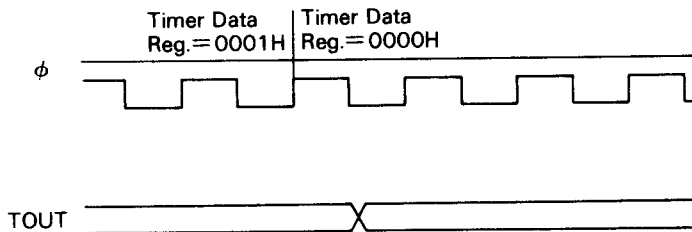

Figure 59 PRT Output Timing

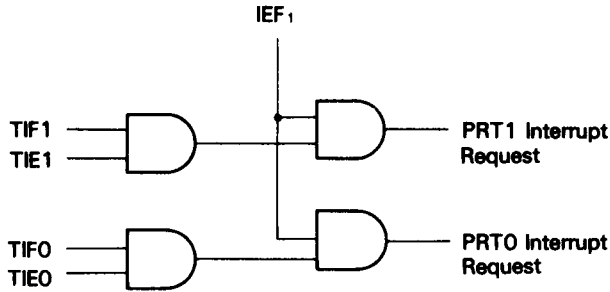

Figure 60 PRT Interrupt Request Circuit Diagram

**13.3 PRT Interrupts**

The PRT interrupt request circuit is shown in Fig. 60.

**13.4 PRT and RESET**

During RESET the bits in TCR are initialized as defined in the TCR register description. Down counting is stopped and the TMDR and RLDR registers are initialized to FFFFH. The  $A_{1n}/TOUT$  pin reverts to the address output function.

**13.5 PRT Operation Notes**

- (1) TMDR data can be accurately read without stopping down counting by reading the lower (TMDRnL\*) and higher (TMDRnH\*) bytes in that order. Or, TMDR can be freely read or written by stopping the down counting.
- (2) Care should be taken to insure that a timer reload does not occur during or between lower (RLDRnL\*) and higher (RLDRnH\*) byte writes. This may be guaranteed by system design/timing or by stopping down counting (with TMDR containing a non-zero value) during the RLDR updating. Similarly, in applications in which TMDR is written at each TMDR overflow, the system/software design should guarantee that RLDR can be updated before the next overflow occurs. Otherwise, time base inaccuracy will occur.  
NOTE: \* n = 0, 1
- (3) During RESET, the multiplexed  $A_{1n}/TOUT$  pin reverts to the address output.  
By reprogramming the TOC1 and TOC0 bits, the timer output

function for PRT channel 1 can be selected. The following shows the initial state of the TOUT pin after TOC1 and TOC0 are programmed to select the PRT channel 1 timer output function.

(i) PRT (channel 1) has not counted down to 0.

If the PRT has not counted down to 0 (timed out), the initial state of TOUT depends on the programmed value in TOC1 and TOC0.

TOC1	TOC0	TOUT State After Programming TOC1/TOC0	TOUT State After Next Timeout
0	1	HIGH (1)	LOW (0)
1	0	HIGH (1)	LOW (0)
1	1	HIGH (1)	HIGH (1)

(ii) PRT (channel 1) has counted down to 0 at least once.

If the PRT has counted down to 0 (timed out) at least once, the initial state of TOUT depends on the number of time outs (even or odd) that have occurred.

Numbers of Timeouts (even or odd)	TOUT State After Programming TOC1/TOC0
Even (2, 4, 6 ...)	HIGH (1)
Odd (1, 3, 5 ...)	LOW (0)

**14 INTERNAL I/O REGISTERS**

The HD64180 internal I/O Registers occupy 64 I/O addresses (including reserved addresses). These registers access the internal I/O modules (ASCI, CSI/O, PRT) and control functions (DMAC, DRAM refresh, interrupts, wait state generator, MMU and I/O relocation).

To avoid address conflicts with external I/O, the HD64180 internal I/O addresses can be relocated on 64 bytes boundaries within the bottom 256 bytes of the 64k bytes I/O address space.

**14.1 I/O Control Register (ICR)**

ICR allows relocating of the internal I/O addresses. ICR also controls enabling/disabling of the IOSTOP mode.

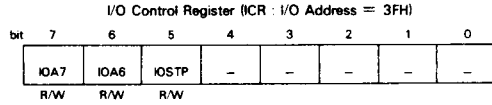

**IOA7,6: I/O Address Relocation (bits 7-6)**

IOA7 and IOA6 relocate internal I/O as shown in Fig. 61. Note that the high-order 8 bits of 16-bit internal I/O addresses are always 0. IOA7 and IOA6 are cleared to 0 during RESET.

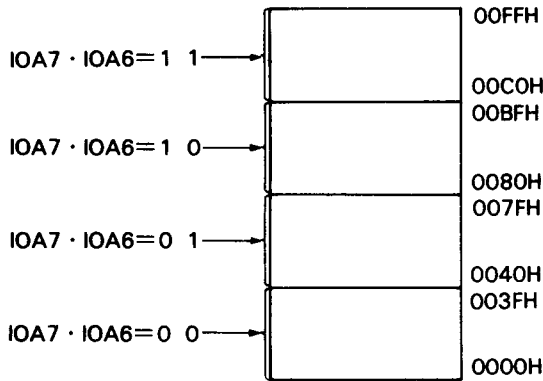

Figure 61 Internal I/O Address Relocation

**IOSTP: IOSTOP Mode (bit 5)**

IOSTOP mode is enabled when IOSTP is set to 1. Normal I/O operation resumes when IOSTP is reset to 0. IOSTP is cleared to 0 during RESET.

**14.2 Internal I/O Registers Address Map**

The internal I/O register addresses are shown in Table 14. These addresses are relative to the 64 bytes boundary base address specified in ICR.

Table 14 Internal I/O Register Address Map (1)

	Register	Mnemonic	Address	
			Binary	Hexadecimal
ASCI	ASCI Control Register A Ch 0	CNTLA0	XX000000	00H
	ASCI Control Register A Ch 1	CNTLA1	XX000001	01H
	ASCI Control Register B Ch 0	CNTLB0	XX000010	02H
	ASCI Control Register B Ch 1	CNTLB1	XX000011	03H
	ASCI Status Register Ch 0	STAT0	XX000100	04H
	ASCI Status Register Ch 1	STAT1	XX000101	05H
	ASCI Transmit Data Register Ch 0	TDR0	XX000110	06H
	ASCI Transmit Data Register Ch 1	TDR1	XX000111	07H
	ASCI Receive Data Register Ch 0	RDR0	XX001000	08H
ASCI Receive Data Register Ch 1	RDR1	XX001001	09H	
CSI/O	CSI/O Control Register	CNTR	XX001010	0AH
	CSI/O Transmit/Receive Data Register	TRDR	XX001011	0BH
Timer	Timer Data Register Ch 0L	TMDROL	XX001100	0CH
	Timer Data Register Ch 0H	TMDROH	XX001101	0DH
	Reload Register Ch 0L	RLDROL	XX001110	0EH
	Reload Register Ch 0H	RLDROH	XX001111	0FH
	Timer Control Register	TCR	XX010000	10H
	Reserved		XX010001	11H
			§	§
			XX010011	13H
	Timer Data Register Ch 1L	TMDR1L	XX010100	14H
	Timer Data Register Ch 1H	TMDR1H	XX010101	15H
Reload Register Ch 1L	RLDR1L	XX010110	16H	
Reload Register Ch 1H	RLDR1H	XX010111	17H	
Others	Free Running Counter	FRC	XX011000	18H
	Reserved		XX011001	19H
			§	§
		XX011111	1FH	



Table 14 Internal I/O Register Address Map (2)

	Register	Mnemonic	Address	
			Binary	Hexadecimal
DMA	DMA Source Address Register Ch 0L	SAR0L	XX100000	20H
	DMA Source Address Register Ch 0H	SAR0H	XX100001	21H
	DMA Source Address Register Ch 0B	SAR0B	XX100010	22H
	DMA Destination Address Register Ch 0L	DAR0L	XX100011	23H
	DMA Destination Address Register Ch 0H	DAR0H	XX100100	24H
	DMA Destination Address Register Ch 0B	DAR0B	XX100101	25H
	DMA Byte Count Register Ch 0L	BCROL	XX100110	26H
	DMA Byte Count Register Ch 0H	BCR0H	XX100111	27H
	DMA Memory Address Register Ch 1L	MAR1L	XX101000	28H
	DMA Memory Address Register Ch 1H	MAR1H	XX101001	29H
	DMA Memory Address Register Ch 1B	MAR1B	XX101010	2AH
	DMA I/O Address Register Ch 1L	IAR1L	XX101011	2BH
	DMA I/O Address Register Ch 1H	IAR1H	XX101100	2CH
	Reserved		XX101101	2DH
	DMA Byte Count Register Ch 1L	BCR1L	XX101110	2EH
	DMA Byte Count Register Ch 1H	BCR1H	XX101111	2FH
	DMA Status Register	DSTAT	XX110000	30H
	DMA Mode Register	DMODE	XX110001	31H
DMA/WAIT Control Register	DCNTL	XX110010	32H	
INT	IL Register (Interrupt Vector Low Register)	IL	XX110011	33H
	INT/TRAP Control Register	ITC	XX110100	34H
	Reserved		XX110101	35H
Refresh	Refresh Control Register	RCR	XX110110	36H
	Reserved		XX110111	37H
MMU	MMU Common Base Register	CBR	XX111000	38H
	MMU Bank Base Register	BBR	XX111001	39H
	MMU Common/Bank Area Register	CBAR	XX111010	3AH
I/O	Reserved		XX111011	3BH
			XX111110	3EH
	I/O Control Register	ICR	XX111111	3FH

3

**14.3 I/O Addressing Notes**

The internal I/O register addresses are located in the I/O address space from 0000H to 00FFH (16-bit I/O addresses). Thus, to access the internal I/O registers (using I/O instructions), the high-order 8 bits of the 16-bit I/O address must be 0.

The conventional I/O instructions (OUT (m), A/ IN A, (m) / OUTI / INI/ etc.) place the contents of a CPU register on the high-order 8 bits of the address bus, and thus may be difficult to use for accessing internal I/O registers.

For efficient internal I/O register access, a number of new instructions have been added, which force the high-order 8 bits of the 16-bit I/O address to 0. These instructions are IN0, OUT0, OTIM,

OTIMR, OTDM, OTDMR and TSTIO (See section 19 Instruction Set).

Note that when writing to an internal I/O register, the same I/O write occurs on the external bus. However, the duplicate external I/O write cycle will exhibit internal I/O write cycle timing. For example, the WAIT input and programmable wait state generator are ignored. Similarly, internal I/O read cycles also cause a duplicate external I/O read cycle — however, the external read data is ignored by the HD64180.

Normally, external I/O addresses should be chosen to avoid overlap with internal I/O addresses to avoid duplicate I/O accesses.

# HD64180R/Z

## 15 E CLOCK OUTPUT TIMING — 6800 TYPE BUS INTERFACE

A large selection of 6800 type peripheral devices can be connected to the HD64180, including the Hitachi 6300 CMOS series (6321 PIA, 6350 ACIA, etc.) as well as 6500 family devices.

These devices require connection with the HD64180 synchronous E clock output. The speed (access time) required for the peripheral device are determined by the HD64180 clock rate. Table 15, Fig. 62 and Fig. 63 define E clock output timing.

Table 15 E Clock Timing in Each Condition

Condition	Duration of E Clock Output "High"
Op-code Fetch Cycle Memory Read/Write Cycle	$T_2 \uparrow - T_3 \downarrow$ $(1.5\phi + n_w \cdot \phi)$
I/O read Cycle	$1st\ Tw \uparrow - T_3 \downarrow$ $(0.5\phi + n_w \cdot \phi)$
I/O Write Cycle	$1st\ Tw \uparrow - T_3 \downarrow$ $(n_w \cdot \phi)$
NMI Acknowledge 1st MC	$T_2 \uparrow - T_3 \downarrow$ $(1.5\phi)$
INT <sub>0</sub> Acknowledge 1st MC	$1st\ Tw \uparrow - T_3 \downarrow$ $(0.5\phi + n_w \cdot \phi)$
BUS RELEASE mode SLEEP mode SYSTEM STOP mode	$\phi \downarrow - \phi \downarrow$ $(2\phi\text{ or }1\phi)$

NOTE)  $n_w$  : the number of wait states  
MC : Machine Cycle

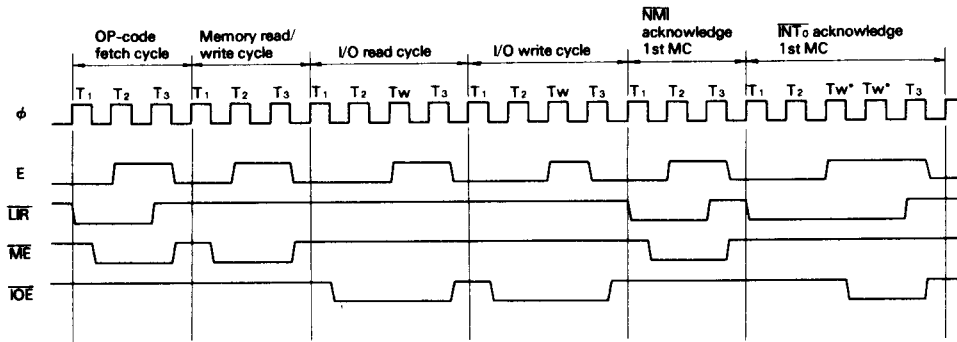

NOTE) MC: Machine Cycle

\* Two wait states are automatically inserted.

Figure 62 E Clock Timing (During Read/Write Cycle and Interrupt Acknowledge Cycle)

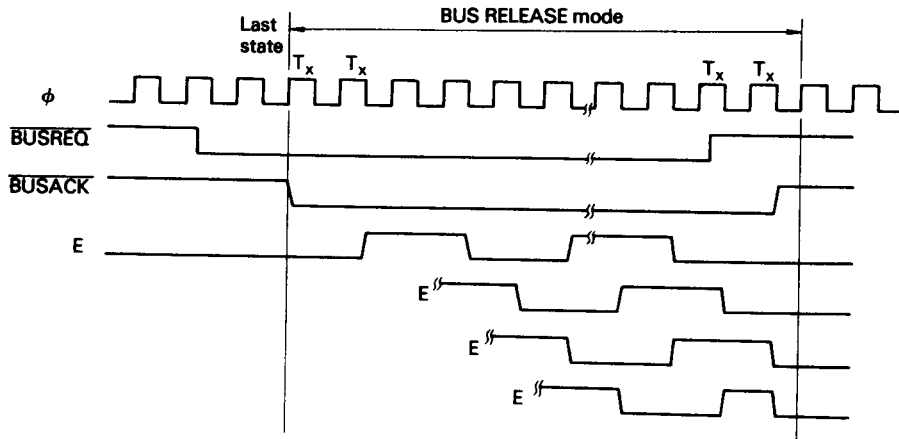

(a) E Clock Timing in BUS RELEASE Mode

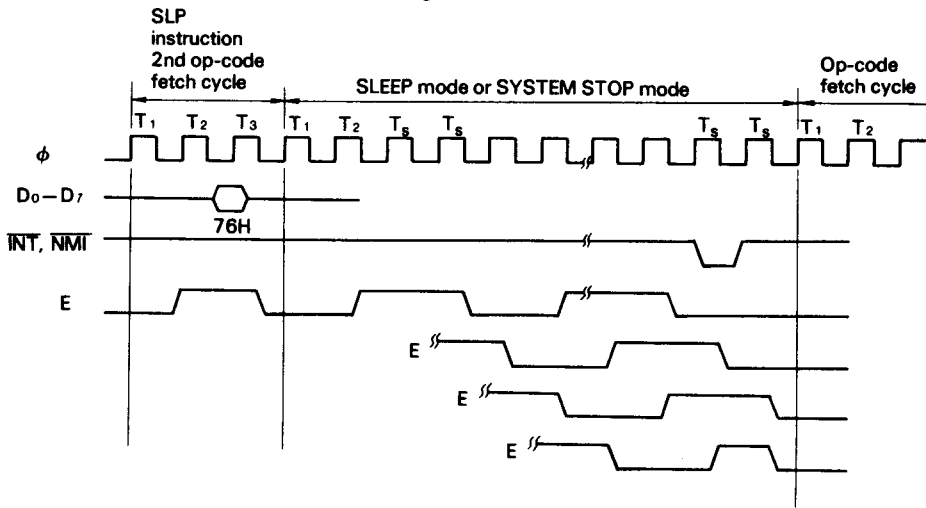

(b) E Clock Timing in SLEEP Mode and SYSTEM STOP Mode

Figure 63 E Clock Timing  
(in BUS RELEASE mode, SLEEP mode, SYSTEM STOP mode)

Wait states inserted in op-code fetch, memory read/write and I/O read/write cycles extend the duration of E clock output HIGH. Note that during I/O read/write cycles with no wait states (only occurs during on-chip I/O register accesses), E will not go HIGH.

The correspondence between the duration of E clock output HIGH and standard peripheral device speed selections is as follows.

Device Speed Selection	Required duration of E clock output HIGH
1.0 MHz (ex: HD6321P)	500 ns min.
1.5 MHz (ex: HD63A21P)	333 ns min.
2.0 MHz (ex: HD63B21P)	230 ns min.

### 15.1 6800 Type Bus Interfacing Note

When the HD64180 is connected to 6800 type peripheral LSIs with E clock, the 6800 type peripheral LSIs should be located in I/O address space.

If the 6800 type peripheral LSIs are located in memory address space, WR set-up time and WR hold time for E clock won't be guaranteed during memory read/write cycles and 6800 type peripheral LSIs can't be connected correctly.

# HD64180R/Z

## 16 ON-CHIP CLOCK GENERATOR

The HD64180 contains a crystal oscillator and system clock ( $\phi$ ) generator. A crystal can be directly connected or an external clock input can be provided. In either case, the system clock ( $\phi$ ) is equal to one-half the input clock. For example, a crystal or external clock

input of 8 MHz corresponds with a system clock rate of  $\phi = 4$  MHz.

The following table shows the AT cut crystal characteristics ( $C_0$ ,  $R_s$ ) and the load capacitance ( $CL_1$ ,  $CL_2$ ) required for various frequencies of HD64180 operation.

Table 16 Crystal Characteristics

Item \ Clock Frequency	4MHz	4MHz < f ≤ 12MHz	12MHz < f ≤ 16MHz
$C_0$	< 7 pF	< 7 pF	< 7 pF
$R_s$	< 60 Ω	< 60 Ω	< 60 Ω
$CL_1, CL_2$	10 to 22 pF ± 10%	10 to 22 pF ± 10%	10 to 22 pF ± 10%

If an external clock input is used instead of a crystal, the waveform (twice the  $\phi$  clock rate) should exhibit a  $50\% \pm 5\%$  duty cycle. Note that the minimum clock input HIGH voltage level is  $V_{CC} - 0.6V$ . The external clock input is connected to the EXTAL pin, while the XTAL pin is left open. Fig. 64 shows external clock interface.

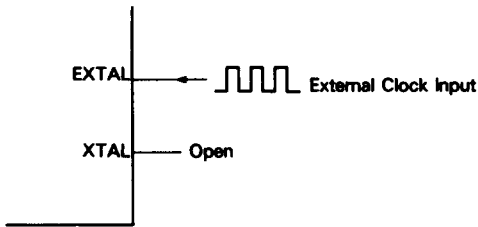

Figure 64 External Clock Interface

Fig. 65 shows the HD64180 clock generator circuit while Fig. 66 and Fig. 67 specify circuit board design rules.

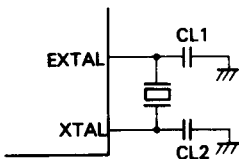

Figure 65 Crystal Interface

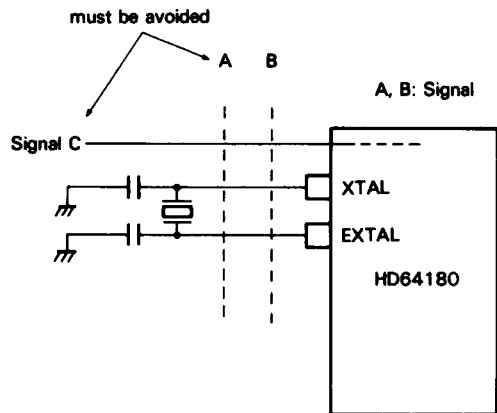
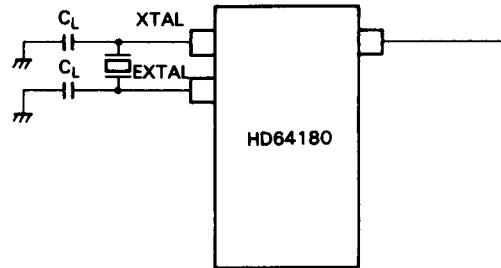

Figure 66 Note for Board Design of the Oscillation Circuit

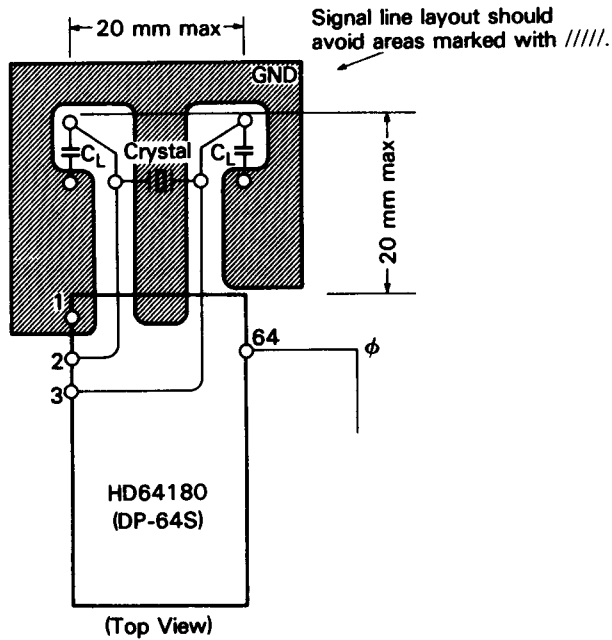

Figure 67 Example of Board Design

Circuit Board design should observe the followings.

- (1) To prevent induced noise, the crystal and load capacitors should be physically located as close to the LSI as possible.
- (2) Signal lines should not run parallel to the clock oscillator inputs. In particular, the clock input circuitry and the system clock  $\phi$  output should be separated as much as possible.
- (3) Similar to (2),  $V_{CC}$  power lines should be separated from the clock oscillator input circuitry.
- (4) Resistivity between XTAL or EXTAL and the other pins should be greater than 10M ohms.  
Signal line layout should avoid areas marked with ////.

# HD64180R/Z

## 17 MISCELLANEOUS

Free Running Counter (I/O Address = 18H)

Read only 8-bit free running counter without control registers and status registers. The contents of the 8-bit free running counter is counted down by 1 with an interval of 10  $\phi$  clock cycles. The free running counter continues counting down without being affected by the read operation.

If data is written into the free running counter, we can't guarantee the interval of DRAM refresh cycle and baud rates of ASCII and CSI/O.

In IOSTOP mode, the free running counter continues counting down. It is initialized to FFH during RESET.

## 18 OPERATION NOTES

### 18.1 Precaution on Interfacing the Z80\* Family Peripheral LSIs to the HD64180

#### (1) Problem

In daisy chain, the Z80\* family peripheral LSI (PIO, DMA, CTC, SIO, or DART) resets interrupt circuit (i.e. IEO changes from LOW to HIGH) by fetching the RETI op-code on the data bus concurrently during the CPU fetches the RETI. Therefore, the followings should be noted for the RETI op-code (EDH, 4DH) fetch timing in the Z80\* peripheral LSI.

When the peripheral LSI fetches the first op-code of RETI (EDH),  $\overline{LIR}$  should be negated HIGH at the rising edge of system clock  $\phi$  as shown in Fig. 71, A. (This isn't referred in the manuals for the Z80\* peripheral LSI.) So,  $\overline{LIR}$  hold time ( $\overline{LIR} = \text{HIGH}$ ) should be required as shown in Fig. 71.

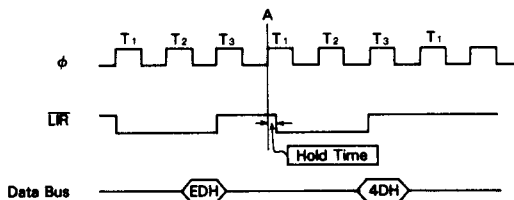

Figure 71  $\overline{LIR}$  Hold Time

Because  $\overline{LIR}$  changes synchronously with the rising edge of system clock  $\phi$ ,  $\overline{LIR}$  delay time is equal to  $\overline{LIR}$  hold time of the Z80\* peripheral LSI. However, this  $\overline{LIR}$  hold time may not be sufficient for the Z80\* peripheral LSI in some case and IEO line may not be reset.

#### (2) An example of countermeasure

Fig. 72 shows an example of circuit, while Fig. 73 shows the  $\overline{LIR}$  and  $\overline{LIR}'$  timing in the circuit.

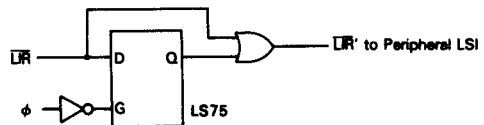

Figure 72 Circuit Example

\* Z80 is a registered trademark of Zilog, Inc.

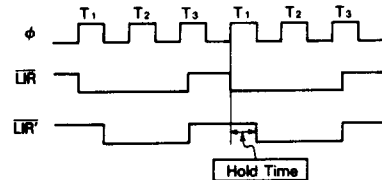

Figure 73  $\overline{LIR}$  and  $\overline{LIR}'$  Timing in the Circuit

$\overline{LIR}'$ , which is synchronized with the falling edge of system clock  $\phi$ , is provided to the peripheral LSI. In this case, one-half clock cycle duration is confirmed as the hold time.

Please carefully examine the circuit before you use it on your application.

**18.5 Precaution on Interfacing HD64180 with Z80\* CTC**  
**(1) Problem**

The following problem may happen when interfacing HD64180 with Z80\* CTC (Z8430). Therefore, countermeasure shown in section 2 should be taken. Fig. 81 illustrates Z80\* CTC write timing specified in Z80\* CTC Data Sheet. Fig. 82 and Fig. 83 show Z80\* I/O write timing and HD64180 I/O write timing respectively.

As shown above,  $\overline{IOE}$  in HD64180 goes LOW by a half  $\phi$  clock cycle faster than  $\overline{IORQ}$  in Z80. When interfacing Z80 with Z80\* CTC, data is written into Z80\* CTC at the rising edge of  $T_w$ . By contrast, when interfacing HD64180 with Z80\* CTC, data is written into Z80\* CTC at the rising edge of  $T_2$ . In the latter case, data may not be written into Z80\* CTC if  $\overline{IOE}$  set-up time for the rising edge of  $T_2$  is less than the set-up time specified in Z80\* CTC.

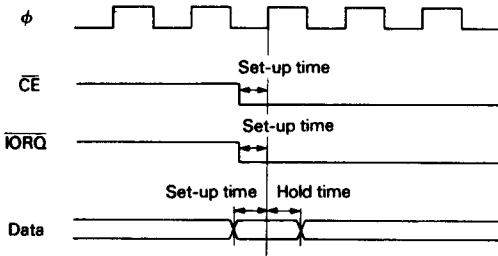

Figure 81 Z80\* CTC Write Timing\*\*

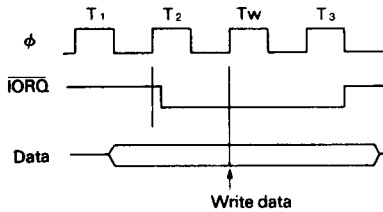

Figure 82 Z80\* I/O Write Timing

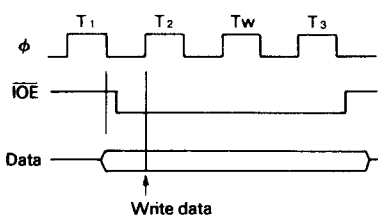
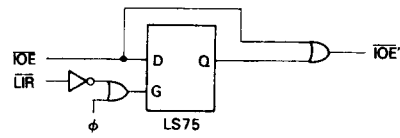

Figure 83 HD64180 I/O Write Timing

**(2) Countermeasure**

To Avoid the problem,  $\overline{IOE}$  in HD64180 should be asserted LOW at the rising edge of  $T_2$  to assure the set-up time specified in Z80\* CTC. Fig. 84 (a) shows a circuit for delaying  $\overline{IOE}$  by a half  $\phi$  clock cycle.

If this circuit is externally connected between HD64180 and Z80\* CTC,  $\overline{IOE}$  will be pulled LOW at the rising edge of  $T_2$  only in I/O read/write cycle as shown in Fig. 84 (b). While in  $\overline{INT}_0$  acknowledge cycle,  $\overline{IOE}$  and  $\overline{IOE}$  are asserted LOW at the timing shown in Fig. 84 (c). In  $\overline{INT}_0$  acknowledge cycle,  $\overline{IOE}$  delays because of propagation time of TTL gates of the countermeasure circuit and the vector access time is shortened. If vector access time for HD64180 is not assured during  $\overline{INT}_0$  acknowledge cycle, wait states should be inserted by programming IW10 and IW11 bits of DMA/WAIT Control Register. However, note that wait states insertion by software should be inhibited during Z80\* CTC read/write cycles, because more than one wait state can not be allowed in the case of Z80\* CTC. (Please see Z80\* CTC Data Sheet. One wait state is automatically inserted during the cycles.) Refer to "Fig. 85 Z80\* CTC Access Flow" for details.



(a) Countermeasure Circuit

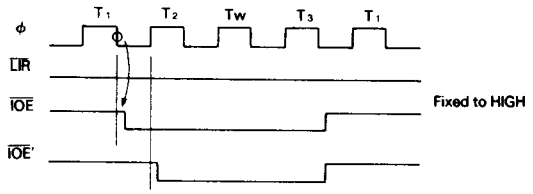

(b) I/O Read/Write Timing

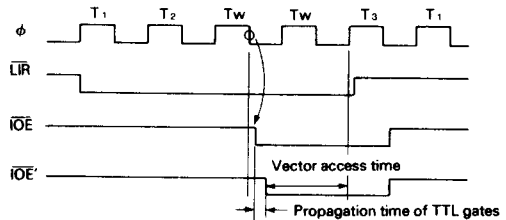

(c)  $\overline{INT}_0$  Acknowledge Cycle Timing

Figure 84 Countermeasure Circuit and Timings in the Circuit

\* Z80 is a registered trademark of Zilog, Inc.  
 \*\* Copied from Z80\* CTC Data Sheet (April, 1985)

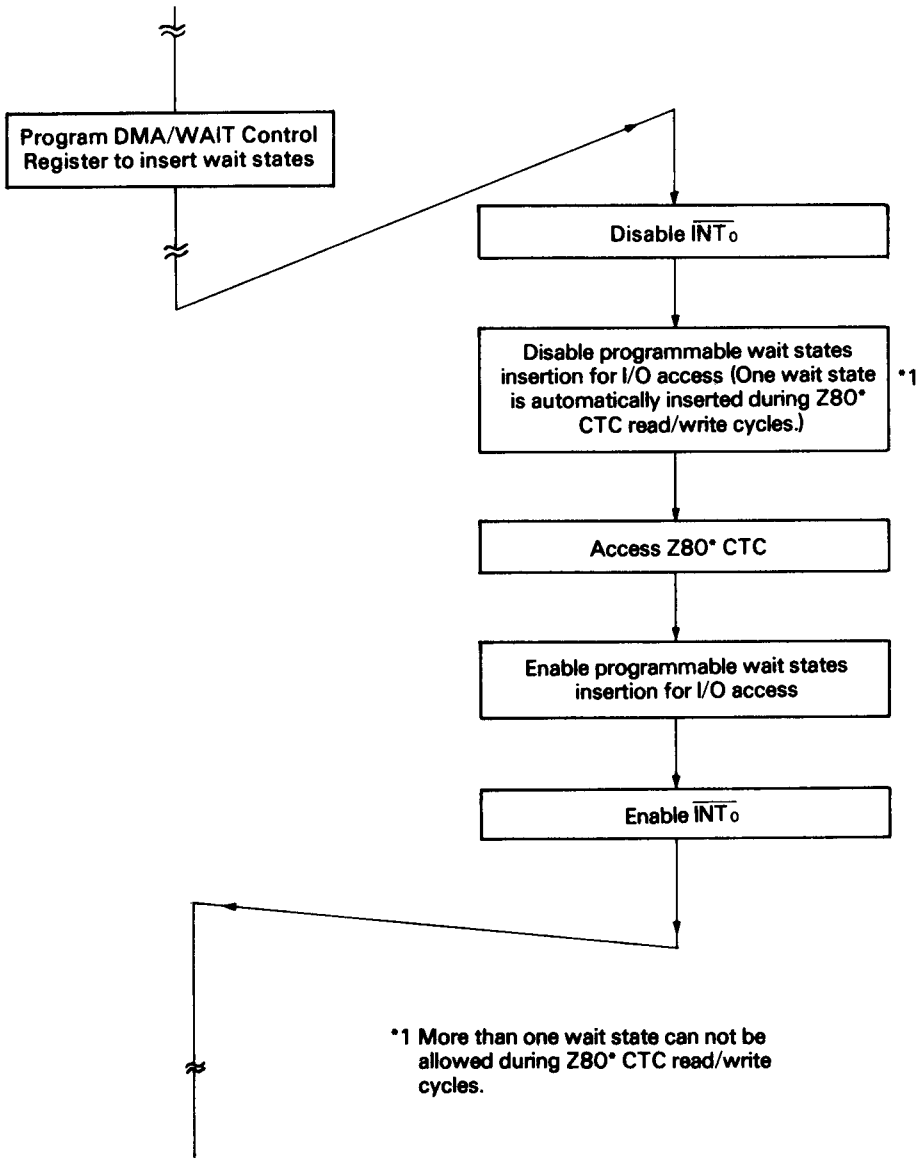

Figure 85 Z80 CTC Access Flow



18.6 Notes on HD64180  $\overline{INT}_0$  Mode 0

(1) Problem

In  $\overline{INT}_0$  Mode 0, the CPU executes an instruction which is placed on the data bus during the interrupt acknowledge cycle. Usually, RST (1-byte instruction) or CALL (3-byte instruction) is placed on the data bus. Then, the CPU pushes the Program Counter (PC) onto the stack and jumps to the interrupt service routine. In the case of RST instruction, the correct return address is pushed onto the stack. However, in the case of CALL instruction, the pushed return address is equal to the correct return address + 2.

(2) Explanation of operation

During the 1st op-code fetch cycle in the interrupt acknowledge

cycle, the CPU stops incrementing the PC. At this time, the PC contains the return address. After the 1st op-code is fetched, the CPU restarts incrementing the PC. Therefore, if RST (1-byte instruction) is executed in the interrupt acknowledge cycle, the correct return address is pushed onto the stack and the CPU can return from the interrupt service routine correctly. While, if CALL (3-byte instruction) is executed in the interrupt acknowledge cycle, the PC is incremented twice during the operand read cycle of the 2 bytes after the 1st op-code is fetched. Therefore, the return address + 2 in the PC is pushed onto the stack. So, when RETI is executed at the end of the interrupt service routine, the CPU can not return from the interrupt correctly.

Fig. 86 shows the CALL execution timing in  $\overline{INT}_0$  Mode 0.

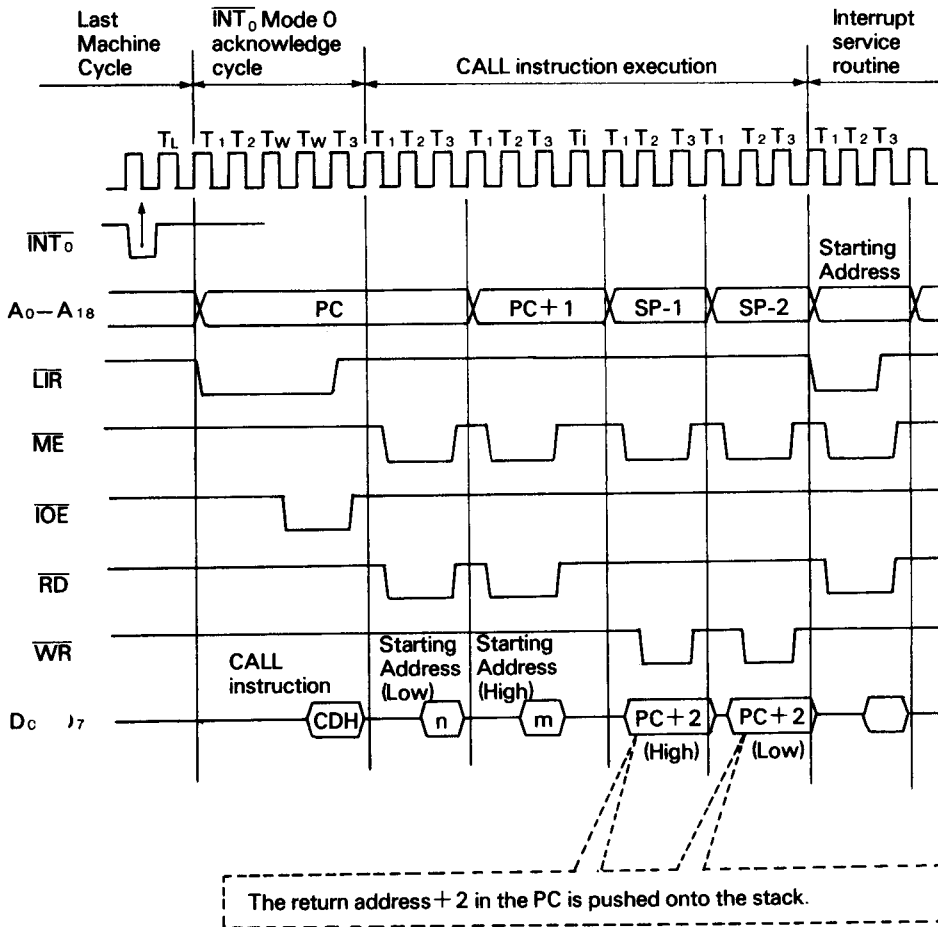

Figure 86 The CALL Execution Timing in  $\overline{INT}_0$  Mode 0

# HD64180R/Z

## (3) Countermeasure

The following explains the countermeasure of the problem in  $\overline{\text{INT}}_0$  Mode 0.

- ① RST  
When RST is executed, the correct return address in the PC is pushed onto the stack.
- ② CALL  
When CALL is executed, the stack contents must be decremented by two in the interrupt service routine to return from the interrupt correctly.

Table 18 summarizes how to adjust the stack contents depending on the instruction to be executed.

Table 18 Stack Contents Adjustment

Instruction	Stack Contents Adjustment
RST	No
CALL	Decrement the stack contents by two
Other instructions	No (The PC is not stacked.)

The  $\overline{\text{INT}}_0$  Mode 0 sequences when executing RST and CALL are shown in Fig. 87.

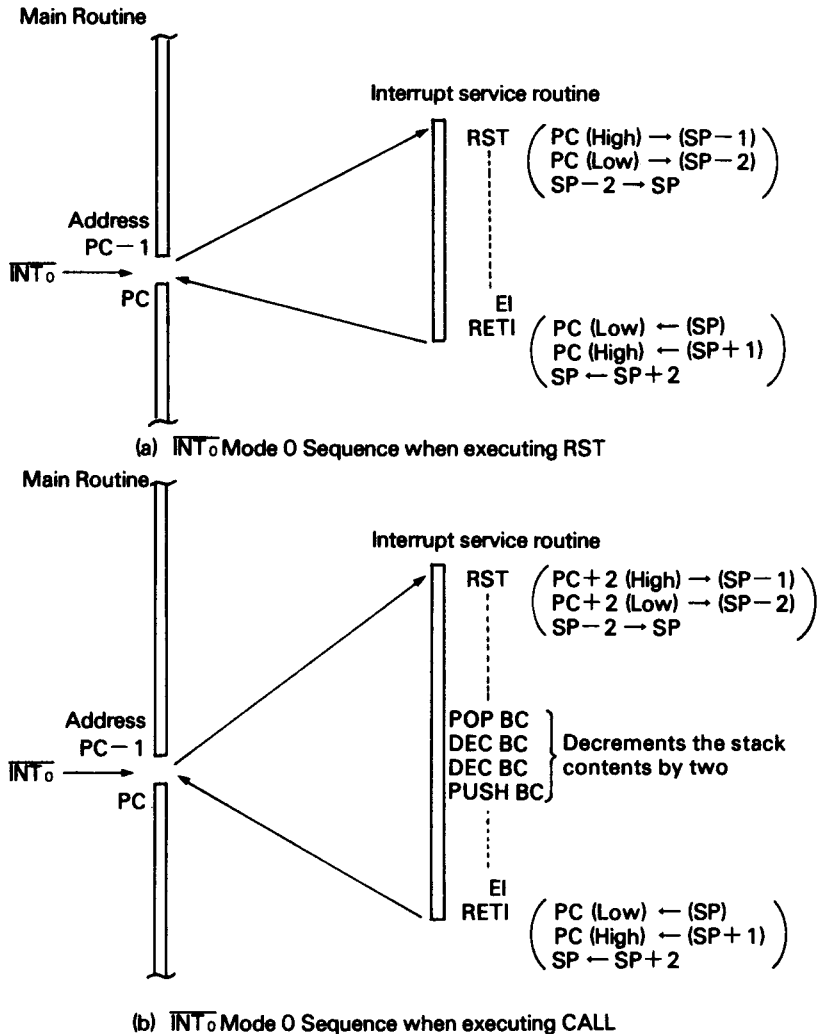

NOTE) PC: PC indicates the return address

Figure 87  $\overline{\text{INT}}_0$  Mode 0 Sequence

**19 INSTRUCTION SET**

**19.1 Instruction set overview**

The HD64180 is object code compatible with standard 8-bit operating system and application software. The instruction set also contains a number of new instructions to improve system and software performance, reliability and efficiency.

New Instructions	Operation
SLP	Enter SLEEP mode
MLT	8-bit multiply with 16-bit result
INO g, (m)	Input contents of immediate I/O address into register
OUT0 (m), g	Output register contents to immediate I/O address
OTIM	Block output – increment
OTIMR	Block output – increment and repeat
OTDM	Block output – decrement
OTDMR	Block output – decrement and repeat
TSTIO m	Non-destructive AND, I/O port and accumulator
TST g	Non-destructive AND, register and accumulator
TST m	Non-destructive AND, immediate data and accumulator
TST (HL)	Non-destructive AND, memory data and accumulator

**(1) SLP – Sleep**

The SLP instruction causes the HD64180 to enter SLEEP low power consumption mode. See section 5 for a complete description of the SLEEP state.

**(2) MLT – Multiply**

The MLT performs unsigned multiplication on two 8 bit numbers yielding a 16 bit result. MLT may specify BC, DE, HL or SP

registers. In all cases, the 8-bit operands are loaded into each half of the 16-bit register and the 16-bit result is returned in that register.

**(3) INO g, (m) – Input, Immediate I/O address**

The contents of immediately specified 8-bit I/O address are input into the specified register. When I/O is accessed, 00H is output in high-order bits of address automatically.

**(4) OUT0 (m), g – Output, immediate I/O address**

The contents of the specified register are output to the immediately specified 8-bit I/O address. When I/O is accessed, 00H is output in high-order bits of address automatically.

**(5) OTIM, OTIMR, OTDM, OTDMR – Block I/O**

The contents of memory pointed to by HL is output to the I/O address in (C). The memory address (HL) and I/O address (C) are incremented in OTIM and OTIMR and decremented in OTDM and OTDMR respectively. B register is decremented. The OTIMR and OTDMR variants repeat the above sequence until register B is decremented to 0. Since the I/O address (C) is automatically incremented or decremented, these instructions are useful for block I/O (such as HD64180 on-chip I/O) initialization. When I/O is accessed, 00H is output in high-order bits of address automatically.

**(6) TSTIO m – Test I/O Port**

The contents of the I/O port addressed by C are ANDed with 8-bit immediate data and the status flags are updated. The I/O port contents are not written (non-destructive AND). When I/O is accessed, 00H is output in higher bits of address automatically.

**(7) TST g – Test Register**

The contents of the specified register are ANDed with the accumulator (A) and the status flags are updated. The accumulator and specified register are not changed (non-destructive AND).

# HD64180R/Z

## (8) TST m – Test Immediate

The 8-bit immediate data is ANDED with the accumulator (A) and the status flags are updated. The accumulator is not changed (non-destructive AND).

## (9) TST (HL) – Test Memory

The contents of memory pointed to by HL are ANDED with the accumulator (A) and the status flags are updated. The memory contents and accumulator are not changed (non-destructive AND).

## 19.2 Instruction set summary

The followings explain the symbols in instruction set, and the following tables summarize the operation of each instruction.

### (1) Register

g, g', ww, xx, yy, and zz specify a register to be used. g and g' specify an 8-bit register. ww, xx, yy, and zz specify a pair of 16-bit registers. The following tables show the correspondence between symbols and registers.

g,g'	Reg.	ww	Reg.	xx	Reg.	yy	Reg.	zz	Reg.
000	B	00	BC	00	BC	00	BC	00	BC
001	C	01	DE	01	DE	01	DE	01	DE
010	D	10	HL	10	IX	10	IY	10	HL
011	E	11	SP	11	SP	11	SP	11	AF
100	H								
101	L								
111	A								

NOTE: Suffixed H and L to ww,xx,yy,zz (ex wwH,IXL) indicate upper and lower 8-bit of the 16-bit register respectively.

### (2) Bit

b specifies a bit to be manipulated in the bit manipulation instruction. The following table shows the correspondence between b and bits.

b	Bit
000	0
001	1
010	2
011	3
100	4
101	5
110	6
111	7

### (3) Condition

f specifies the condition in program control instructions. The following shows the correspondence between f and conditions.

f	Condition
000	NZ non zero
001	Z zero
010	NC non carry
011	C carry
100	PO parity odd
101	PE parity even
110	P sign plus
111	M sign minus

### (4) Restart Address

v specifies a restart address. The following table shows the correspondence between v and restart addresses.

v	Address
000	00H
001	08H
010	10H
011	18H
100	20H
101	28H
110	30H
111	38H

### (5) Flag

The following symbols show the flag conditions.

- : not affected
- ↑ : affected
- × : undefined
- S : set to 1
- R : reset to 0
- P : parity
- V : overflow

### (6) Miscellaneous

- ( )<sub>M</sub> : data in the memory address
- ( )<sub>I</sub> : data in the I/O address
- m or n : 8-bit data
- mn : 16-bit data
- r : 8-bit register
- R : 16-bit register
- b-( )<sub>M</sub> : a content of bit b in the memory address
- b-gr : a content of bit b in the register gr
- d or j : 8-bit signed displacement
- S : source addressing mode
- D : destination addressing mode
- : AND operation
- +
- ⊕ : EXCLUSIVE OR operation

Data Manipulation Instructions

Arithmetic and Logical Instructions (8-bit)

Operation name	MNEEMONCS	OP-code	Addressing								Bytes	States	Operation	Flag							
			IMMED	EXT	IND	REG	REGI	IMP	REL	7				6	4	2	1	0			
																			S	Z	H
ADD	ADD A,g	10 000 g				S		D		1	4	$Ar + gr - Ar$				V	R				
	ADD A, (HL)	10 000 110						S	D	1	6	$Ar + (HL)_8 - Ar$				V	R				
	ADD A,m	11 000 110	S						D	2	6	$Ar + m - Ar$				V	R				
	< m >																				
	ADD A, (X+d)	11 011 101			S				D	3	14	$Ar + (X+d)_8 - Ar$				V	R				
	< d >																				
ADC	ADC A,g	10 001 g				S		D		1	4	$Ar + gr + c - Ar$				V	R				
	ADC A, (HL)	10 001 110						S	D	1	6	$Ar + (HL)_8 + c - Ar$				V	R				
	ADC A,m	11 001 110	S						D	2	6	$Ar + m + c - Ar$				V	R				
	< m >																				
	ADC A, (X+d)	11 011 101			S				D	3	14	$Ar + (X+d)_8 + c - Ar$				V	R				
	< d >																				
AND	AND g	10 100 g				S		D		1	4	$Ar \cdot gr - Ar$				S	P	R	R		
	AND (HL)	10 100 110						S	D	1	6	$Ar \cdot (HL)_8 - Ar$				S	P	R	R		
	AND m	11 100 110	S						D	2	6	$Ar \cdot m - Ar$				S	P	R	R		
	< m >																				
	AND (X+d)	11 011 101			S				D	3	14	$Ar \cdot (X+d)_8 - Ar$				S	P	R	R		
	< d >																				
Compare	CP g	10 111 g				S		D		1	4	$Ar - gr$				V	S				
	CP (HL)	10 111 110						S	D	1	6	$Ar - (HL)_8$				V	S				
	CP m	11 111 110	S						D	2	6	$Ar - m$				V	S				
	< m >																				
	CP (X+d)	11 011 101			S				D	3	14	$Ar - (X+d)_8$				V	S				
	< d >																				
COMPLEMENT	CPL	00 101 111						S/D		1	3	$\bar{Ar} - Ar$	.	.	S	.	S	.			
DEC	DEC g	00 g 101				S/D				1	4	$gr - 1 - gr$				V	S	.			
	DEC (HL)	00 110 101						S/D		1	10	$(HL)_8 - 1 - (HL)_8$				V	S	.			
	DEC (X+d)	11 011 101			S/D					3	18	$(X+d)_8 - 1 - (X+d)_8$				V	S	.			
	< d >																				
	DEC (Y+d)	11 111 101			S/D					3	18	$(Y+d)_8 - 1 - (Y+d)_8$				V	S	.			
	< d >																				
INC	INC g	00 g 100				S/D				1	4	$gr + 1 - gr$				V	R	.			
	INC (HL)	00 110 100						S/D		1	10	$(HL)_8 + 1 - (HL)_8$				V	R	.			
	INC (X+d)	11 011 101			S/D					3	18	$(X+d)_8 + 1 - (X+d)_8$				V	R	.			





(to be continued)

HD64180R/Z

Operation name	MNEMONICS	OP-code	Addressing							Bytes	Status	Operation	Flag							
			IMMED	EXT	IND	REG	REGI	IMP	REL				7	6	4	2	1	0		
													S	Z	H	P/V	N	C		
INC	INC RY+d	< d >			S/D					3	18	RY + d <sub>16</sub> + 1 RY + d <sub>16</sub>	[	]	[	]	V	R	.	
		11 111 101																		
		00 110 100																		
		< d >																		
MULT	MLT ww	11 101 101 01 ww1 100				S/D				2	17	ww1x ww1-ww1	.	.	.	.	.	.	.	
NEGATE	NEG	11 101 101 01 000 100						S/D		2	6	0-Ar-Ar	[	]	[	]	V	S	[	
OR	OR g	10 110 g				S		D		1	4	Ar + gr-Ar	[	]	[	]	R	P	R	R
	OR #HJ	10 110 110						S	D	1	6	Ar + #HJ <sub>16</sub> -Ar	[	]	[	]	R	P	R	R
	OR m	11 110 110	S					D		2	6	Ar + m-Ar	[	]	[	]	R	P	R	R
		< m >							D				[	]	[	]	R	P	R	R
	OR BX+d	11 011 101 10 110 110			S			D		3	14	Ar + BX + d <sub>16</sub> -Ar	[	]	[	]	R	P	R	R
		< d >				S			D		3	14	Ar + BY + d <sub>16</sub> -Ar	[	]	[	]	R	P	R
SUB	SUB g	10 010 g				S		D		1	4	Ar - gr-Ar	[	]	[	]	V	S	[	
	SUB #HJ	10 010 110						S	D	1	6	Ar - #HJ <sub>16</sub> -Ar	[	]	[	]	V	S	[	
	SUB m	11 010 110	S					D		2	6	Ar - m-Ar	[	]	[	]	V	S	[	
		< m >							D				[	]	[	]	V	S	[	
	SUB BX+d	11 011 101 10 010 110			S			D		3	14	Ar - BX + d <sub>16</sub> -Ar	[	]	[	]	V	S	[	
		< d >				S			D		3	14	Ar - BY + d <sub>16</sub> -Ar	[	]	[	]	V	S	[
SUBC	SBC Ag	10 011 g				S		D		1	4	Ar - gr - c-Ar	[	]	[	]	V	S	[	
	SBC A, #HJ	10 011 110						S	D	1	6	Ar - #HJ <sub>16</sub> - c-Ar	[	]	[	]	V	S	[	
	SBC A, m	11 011 110	S					D		2	6	Ar - m - c-Ar	[	]	[	]	V	S	[	
		< m >							D				[	]	[	]	V	S	[	
	SBC A, BX+d	11 011 101 10 011 110			S			D		3	14	Ar - BX + d <sub>16</sub> - c-Ar	[	]	[	]	V	S	[	
		< d >				S			D		3	14	Ar - BY + d <sub>16</sub> - c-Ar	[	]	[	]	V	S	[
TEST	TST g	11 101 101 00 g 100				S				2	7	Ar + gr	[	]	[	]	S	P	R	R
	TST #HJ	11 101 101 00 110 100						S		2	10	Ar + #HJ <sub>16</sub>	[	]	[	]	S	P	R	R
	TST m	11 101 101 01 100 100	S							3	9	Ar + m	[	]	[	]	S	P	R	R
		< m >										[	]	[	]	S	P	R	R	
XOR	XOR g	10 101 g				S		D		1	4	Ar ⊕ gr-Ar	[	]	[	]	R	P	R	R
	XOR #HJ	10 101 110						S	D	1	6	Ar ⊕ #HJ <sub>16</sub> -Ar	[	]	[	]	R	P	R	R
	XOR m	11 101 110	S					D		2	6	Ar ⊕ m-Ar	[	]	[	]	R	P	R	R
		< m >							D				[	]	[	]	R	P	R	R
	XOR BX+d	11 011 101 10 101 110			S			D		3	14	Ar ⊕ BX + d <sub>16</sub> -Ar	[	]	[	]	R	P	R	R
		< d >				S			D		3	14	Ar ⊕ BY + d <sub>16</sub> -Ar	[	]	[	]	R	P	R

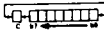

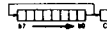

(to be continued)

Rotate and Shift Instructions

Operation name	MNEMONICS	OP-code	Addressing						Bytes	States	Operation	Flag						
			IMMED	EXT	IND	REG	REGI	IMP				REL	7	6	4	2	1	0
													S	Z	H	P/V	N	C
Rotate	RLA	00 010 111				S/D		S/D	1	3		.	.	R	.	R	I	
	RL g	11 001 011				S/D			2	7				R	P	R	I	
and		00 010 g																
	RL #HL	11 001 011						S/D	2	13				R	P	R	I	
Shift		00 010 110																
	RL (X+d)	11 011 101			S/D				4	19				R	P	R	I	
Data		11 001 011																
	RL (Y+d)	11 111 101			S/D				4	19				R	P	R	I	
		11 001 011																
		< d >																
		00 010 110																
	RLCA	00 000 111						S/D	1	3		.	.	R	.	R	I	
	RLC g	11 001 011				S/D			2	7				R	P	R	I	
		00 000 g																
	RLC #HL	11 001 011						S/D	2	13				R	P	R	I	
		00 000 110																
	RLC (X+d)	11 011 101			S/D				4	19				R	P	R	I	
		11 001 011																
		< d >																
		00 000 110																
	RLC (Y+d)	11 111 101			S/D				4	19				R	P	R	I	
		11 001 011																
		< d >																
		00 000 110																
	RLD	11 101 101							S/D	2	16				R	P	R	I
		01 101 111																
	RRA	00 011 111							S/D	1	3		.	.	R	.	R	I
	RR g	11 001 011				S/D			2	7				R	P	R	I	
		00 011 g																
	RR #HL	11 001 011						S/D	2	13				R	P	R	I	
		00 011 110																
	RR (X+d)	11 011 101			S/D				4	19				R	P	R	I	
		11 001 011																
		< d >																
		00 011 110																
	RR (Y+d)	11 111 101			S/D				4	19				R	P	R	I	
		11 001 011																
		< d >																
		00 011 110																
	RRCA	00 001 111							S/D	1	3		.	.	R	.	R	I
	RRC g	11 001 011				S/D			2	7				R	P	R	I	
		00 001 g																
	RRC #HL	11 001 011						S/D	2	13				R	P	R	I	
		00 001 110																
	RRC (X+d)	11 011 101			S/D				4	19				R	P	R	I	
		11 001 011																
		< d >																
		00 001 110																
	RRC (Y+d)	11 111 101			S/D				4	19				R	P	R	I	
		11 001 011																
		< d >																
		00 001 110																

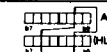
(to be continued)

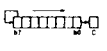
# HD64180R/Z

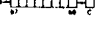
Operation name	MNEMONICS	OP-code	Addressing						Bytes	States	Operation	Flag						
			IMMED	EXT	IND	REG	REGI	IMP				REL	7	6	4	2	1	0
													S	Z	H	P	V	N
Rotate and Shift Data	RRD	11 101 101 01 100 111						S/D		2	16		[	]	R	P	R	]
	SLA g	11 001 011 00 100 g					S/D			2	7		[	]	R	P	R	]
	SLA 16L	11 001 011 00 100 110						S/D		2	13		[	]	R	P	R	]
	SLA 16X + d	11 011 101 11 001 011 < d > 00 100 110				S/D				4	19		[	]	R	P	R	]
	SLA 16Y + d	11 111 101 11 001 011 < d > 00 100 110				S/D				4	19		[	]	R	P	R	]
	SRA g	11 001 011 00 101 g					S/D			2	7		[	]	R	P	R	]
	SRA 16L	11 001 011 00 101 110						S/D		2	13		[	]	R	P	R	]
	SRA 16X + d	11 011 101 11 001 011 < d > 00 101 110				S/D				4	19		[	]	R	P	R	]
	SRA 16Y + d	11 111 101 11 001 011 < d > 00 101 110				S/D				4	19		[	]	R	P	R	]
	SRL g	00 101 110 11 001 011					S/D			2	7		[	]	R	P	R	]
	SRL 16L	11 001 011 00 111 110						S/D		2	13		[	]	R	P	R	]
	SRL 16X + d	11 011 101 11 001 011 < d > 00 111 110				S/D				4	19		[	]	R	P	R	]
	SRL 16Y + d	11 111 101 11 001 011 < d > 00 111 110				S/D				4	19		[	]	R	P	R	]



Bit Manipulation Instructions

Operation name	MNEMONICS	OP-code	Addressing							Bytes	Status	Operation	Flag					
			IMMED	EXT	IND	REG	REGI	IMP	REL				7	6	4	2	1	0
													S	Z	H	P/V	N	C
Bit Set	SET b.g	11 001 011 11 b g				S/D				2	7	1-b · gr	.	.	.	.	.	.
	SET b. #HJ	11 001 011 11 b 110					S/D			2	13	1-b · #HJ <sub>H</sub>	.	.	.	.	.	.
	SET b. BX+d	11 011 101 11 001 011 < d >			S/D					4	19	1-b · BX+d <sub>H</sub>	.	.	.	.	.	.
	SET b. BY+d	11 b 110 11 111 101 11 001 011 < d >			S/D					4	19	1-b · BY+d <sub>H</sub>	.	.	.	.	.	.
Bit Reset	RES b.g	11 001 011 10 b g				S/D				2	7	0-b · gr	.	.	.	.	.	.
	RES b. #HJ	11 001 011 10 b 110					S/D			2	13	0-b · #HJ <sub>H</sub>	.	.	.	.	.	.
	RES b. BX+d	11 011 101 11 001 011 < d >			S/D					4	19	0-b · BX+d <sub>H</sub>	.	.	.	.	.	.
	RES b. BY+d	10 b 110 11 111 101 11 001 011 < d >			S/D					4	19	0-b · BY+d <sub>H</sub>	.	.	.	.	.	.
Bit Test	BIT b.g	11 001 011 01 b g				S				2	6	b · gr-z	X		S	X	R	.
	BIT b. #HJ	11 001 011 01 b 110					S			2	9	b · #HJ <sub>H</sub> -z	X		S	X	R	.
	BIT b. BX+d	11 011 101 11 001 011 < d >			S					4	15	b · BX+d <sub>H</sub> -z	X		S	X	R	.
	BIT b. BY+d	01 b 110 11 111 101 11 001 011 < d >			S					4	15	b · BY+d <sub>H</sub> -z	X		S	X	R	.
		01 b 110																

# HD64180R/Z

## Arithmetic Instructions (16-bit)

Operation name	MNEMONICS	OP-code	Addressing							Bytes	Status	Operation	Flag						
			IMMED	EXT	IND	REG	REGI	IMP	REL				7	6	4	2	1	0	
													S	Z	H	P/V	N	C	
ADD	ADD HL,ww	00 ww1 001				S			D		1	7	$HL_R + ww_R \rightarrow HL_R$	.	.	X	.	R	
	ADD IX,xx	11 011 101				S			D		2	10	$IX_R + xx_R \rightarrow IX_R$	.	.	X	.	R	
	ADD IY,yy	00 xx1 001				S			D		2	10	$IY_R + yy_R \rightarrow IY_R$	.	.	X	.	R	
		00 yy1 001				S			D		2	10	$IY_R + yy_R \rightarrow IY_R$	.	.	X	.	R	
ADC	ADC HL,ww	11 101 101 01 ww1 010				S			D		2	10	$HL_R + ww_R + C \rightarrow HL_R$			X	V	R	
DEC	DEC ww	00 ww1 011				S/D					1	4	$ww_R - 1 \rightarrow ww_R$	.	.	.	.	.	.
	DEC IX	11 011 101				S/D					2	7	$IX_R - 1 \rightarrow IX_R$	.	.	.	.	.	.
	DEC IY	00 101 011				S/D					2	7	$IY_R - 1 \rightarrow IY_R$	.	.	.	.	.	.
		00 101 011				S/D					2	7	$IY_R - 1 \rightarrow IY_R$	.	.	.	.	.	.
INC	INC ww	00 ww0 011				S/D					1	4	$ww_R + 1 \rightarrow ww_R$	.	.	.	.	.	.
	INC IX	11 011 101				S/D					2	7	$IX_R + 1 \rightarrow IX_R$	.	.	.	.	.	.
	INC IY	00 100 011				S/D					2	7	$IY_R + 1 \rightarrow IY_R$	.	.	.	.	.	.
		00 100 011				S/D					2	7	$IY_R + 1 \rightarrow IY_R$	.	.	.	.	.	.
SBC	SBC HL,ww	11 101 101 01 ww0 010				S			D		2	10	$HL_R - ww_R - C \rightarrow HL_R$			X	V	S	

(to be continued)

Data Transfer Instructions

8-Bit Load

Operation name	MNEMONICS	OP-code	Addressing						Bytes	Status	Operation	Flag						
			IMMED	EXT	IND	REG	REGI	IMP				REL	7	6	4	2	1	0
													S	Z	H	P/V	N	C
Load 8-bit	LD AJ	11 101 101 01 010 111						S/D	2	6	R←Ar	I	I	R	EF	R	·	
	LD AR	11 101 101 01 011 111						S/D	2	6	R←Ar	I	I	R	EF	R	·	
Data	LD A, BCJ	00 001 010						S D	1	6	BC <sub>h</sub> ←Ar							
	LD A, DEJ	00 011 010						S D	1	6	DE <sub>h</sub> ←Ar							
	LD A, ImnJ	00 111 010 < n > < m >		S				D D	3	12	Imn <sub>h</sub> ←Ar "							
	LD IA	11 101 101 01 000 111						S/D	2	6	Ar←r							
	LD RA	11 101 101 01 001 111						S/D	2	6	Ar←Rr							
	LD BCJ,A	00 000 010						D S	1	7	Ar←BC <sub>h</sub>							
	LD DEJ,A	00 010 010						D S	1	7	Ar←DE <sub>h</sub>							
	LD ImnJ,A	00 110 010 < n > < m >		D				S	3	13	Ar←Imn <sub>h</sub>							
	LD g,g'	01 g g'					S/D		1	4	g'←gr							
	LD g, ImJ	01 g 110					D	S	1	6	Im <sub>h</sub> ←gr							
	LD g,m	00 g 110 < m >	S				D		2	6	m←gr							
	LD g, BX+d	11 011 101 01 g 110 < d >			S		D		3	14	BX+d <sub>h</sub> ←gr							
	LD g, BY+d	11 111 101 01 g 110 < d >			S		D		3	14	BY+d <sub>h</sub> ←gr							
	LD ImJ,m	00 110 110 < m >	S					D	2	9	m←Im <sub>h</sub>							
	LD BX+d,m	11 011 101 00 110 110 < d > < m >	S		D				4	15	m←BX+d <sub>h</sub>							
	LD BY+d,m	11 111 101 00 110 110 < d > < m >	S		D				4	15	m←BY+d <sub>h</sub>							
	LD ImJ,g	01 110 g					S	D	1	7	gr←Im <sub>h</sub>							
	LD BX+d,g	11 011 101 01 110 g < d >			D		S		3	15	gr←BX+d <sub>h</sub>							
	LD BY+d,g	11 111 101 01 110 g < d >			D		S		3	15	gr←BY+d <sub>h</sub>							

# HD64180R/Z

## 16-Bit Load

Operation name	MNEMONICS	OP-code	Addressing							Bytes	Status	Operation	Flag						
			IMMED	EXT	IND	REG	REG	IMP	REL				7	6	4	2	1	0	
													S	Z	H	P/V	N	C	
Load 16-bit Data	LD ww, mn	00 ww0 001 < n > < m >	S			D					3	9	mn←ww <sub>n</sub>	.	.	.	.	.	.
	LD IX, mn	11 011 101 00 100 001 < n > < m >	S						D		4	12	mn←IX <sub>n</sub>	.	.	.	.	.	.
	LD IY, mn	11 111 101 00 100 001 < n > < m >	S						D		4	12	mn←IY <sub>n</sub>	.	.	.	.	.	.
	LD SP, HL	11 111 001							S/D		1	4	HL <sub>n</sub> ←SP <sub>n</sub>	.	.	.	.	.	.
	LD SP, IX	11 011 101							S/D		2	7	IX <sub>n</sub> ←SP <sub>n</sub>	.	.	.	.	.	.
	LD SP, IY	11 111 001							S/D		2	7	IY <sub>n</sub> ←SP <sub>n</sub>	.	.	.	.	.	.
	LD ww, (mn)	11 101 101 01 ww1 011 < n > < m >		S		D					4	18	(mn+1) <sub>n</sub> ←ww <sub>n</sub> Hr (mn) <sub>n</sub> ←ww <sub>n</sub> Lr	.	.	.	.	.	.
	LD HL, (mn)	00 101 010 < n > < m >		S					D		3	15	(mn+1) <sub>n</sub> ←Hr (mn) <sub>n</sub> ←Lr	.	.	.	.	.	.
	LD IX, (mn)	11 011 101 00 101 010 < n > < m >		S					D		4	18	(mn+1) <sub>n</sub> ←IX <sub>n</sub> Hr (mn) <sub>n</sub> ←IX <sub>n</sub> Lr	.	.	.	.	.	.
	LD IY, (mn)	11 111 101 00 101 010 < n > < m >		S					D		4	18	(mn+1) <sub>n</sub> ←IY <sub>n</sub> Hr (mn) <sub>n</sub> ←IY <sub>n</sub> Lr	.	.	.	.	.	.
	LD (mn), ww	11 101 101 01 ww0 011 < n > < m >		D		S					4	19	ww <sub>n</sub> Hr←(mn+1) <sub>n</sub> ww <sub>n</sub> Lr←(mn) <sub>n</sub>	.	.	.	.	.	.
	LD (mn), HL	00 100 010 < n > < m >		D					S		3	16	Hr←(mn+1) <sub>n</sub> Lr←(mn) <sub>n</sub>	.	.	.	.	.	.
	LD (mn), IX	11 011 101 00 100 010 < n > < m >		D					S		4	19	IX <sub>n</sub> Hr←(mn+1) <sub>n</sub> IX <sub>n</sub> Lr←(mn) <sub>n</sub>	.	.	.	.	.	.
	LD (mn), IY	11 111 101 00 100 010 < n > < m >		D					S		4	19	IY <sub>n</sub> Hr←(mn+1) <sub>n</sub> IY <sub>n</sub> Lr←(mn) <sub>n</sub>	.	.	.	.	.	.

(to be continued)

Block Transfer

Operation name	MNEMONICS	OP-code	Addressing							Bytes	Status	Operation	Flag							
			IMMED	EXT	IND	REG	REGI	IMP	REL				7	6	4	2	1	0		
													S	Z	H	P/V	N	C		
Block Transfer Search Data	CPD	11 101 101					S	S		2	12	Ar = #HL <sub>n</sub> BC <sub>n</sub> - 1 - BC <sub>n</sub> HL <sub>n</sub> - 1 - HL <sub>n</sub>	②	①						
		10 101 001																		
	CPDR	11 101 101					S	S		2	14	BC <sub>n</sub> ≠ 0 Ar ≠ #HL <sub>n</sub> BC <sub>n</sub> = 0 or Ar = #HL <sub>n</sub>			②	①				
		10 111 001										Q { Ar = #HL <sub>n</sub> BC <sub>n</sub> - 1 - BC <sub>n</sub> HL <sub>n</sub> - 1 - HL <sub>n</sub> Repeat Q until Ar = #HL <sub>n</sub> or BC <sub>n</sub> = 0								
	CPI	11 101 101					S	S		2	12	Ar = #HL <sub>n</sub> BC <sub>n</sub> - 1 - BC <sub>n</sub> HL <sub>n</sub> + 1 - HL <sub>n</sub>	②	①						
		10 100 001																		
	CPR	11 101 101					S	S		2	14	BC <sub>n</sub> ≠ 0 Ar ≠ #HL <sub>n</sub> BC <sub>n</sub> = 0 or Ar = #HL <sub>n</sub>			②	①				
		10 110 001										Q { Ar = #HL <sub>n</sub> BC <sub>n</sub> - 1 - BC <sub>n</sub> HL <sub>n</sub> + 1 - HL <sub>n</sub> Repeat Q until Ar = #HL <sub>n</sub> or BC <sub>n</sub> = 0								
	LDD	11 101 101						S/D		2	12	#HL <sub>n</sub> - #DE <sub>n</sub> BC <sub>n</sub> - 1 - BC <sub>n</sub> DE <sub>n</sub> - 1 - DE <sub>n</sub> HL <sub>n</sub> - 1 - HL <sub>n</sub>								①
		10 101 000																		
	LDDR	11 101 101						S/D		2	14 BC <sub>n</sub> ≠ 0 12 BC <sub>n</sub> = 0	Q { #HL <sub>n</sub> - #DE <sub>n</sub> BC <sub>n</sub> - 1 - BC <sub>n</sub> DE <sub>n</sub> - 1 - DE <sub>n</sub> HL <sub>n</sub> - 1 - HL <sub>n</sub> Repeat Q until BC <sub>n</sub> = 0								①
		10 111 000																		
LDI	11 101 101						S/D		2	12	#HL <sub>n</sub> - #DE <sub>n</sub> BC <sub>n</sub> - 1 - BC <sub>n</sub> DE <sub>n</sub> + 1 - DE <sub>n</sub> HL <sub>n</sub> + 1 - HL <sub>n</sub>								①	
	10 100 000																			
LDR	11 101 101						S/D		2	14 BC <sub>n</sub> ≠ 0 12 BC <sub>n</sub> = 0	Q { #HL <sub>n</sub> - #DE <sub>n</sub> BC <sub>n</sub> - 1 - BC <sub>n</sub> DE <sub>n</sub> + 1 - DE <sub>n</sub> HL <sub>n</sub> + 1 - HL <sub>n</sub> Repeat Q until BC <sub>n</sub> = 0								①	
	10 110 000																			

① P/V = 0 : BC<sub>n</sub> - 1 = 0  
P/V = 1 : BC<sub>n</sub> - 1 ≠ 0  
② Z = 1 : Ar = #HL<sub>n</sub>  
Z = 0 : Ar ≠ #HL<sub>n</sub>

# HD64180R/Z

## Stack and Exchange

Operation name	MNEMONICS	OP-code	Addressing							Bytes	States	Operation	Flag						
			IMMED	EXT	IND	REG	REGI	IMP	REL				7	6	4	2	1	0	
													S	Z	H	P/V	N	C	
PUSH	PUSH zz	11 zz0 101				S		D		1	11	zzL ← SP - 2 <sub>W</sub> zzH ← SP - 1 <sub>W</sub> SP <sub>H</sub> - 2 ← SP <sub>H</sub>	.	.	.	.	.	.	
	PUSH IX	11 011 101						S/D		2	14	IXL ← SP - 2 <sub>W</sub> IXH ← SP - 1 <sub>W</sub> SP <sub>H</sub> - 2 ← SP <sub>H</sub>	.	.	.	.	.	.	
		11 100 101							S/D		2	14	IYL ← SP - 2 <sub>W</sub> IYH ← SP - 1 <sub>W</sub> SP <sub>H</sub> - 2 ← SP <sub>H</sub>	.	.	.	.	.	.
	PUSH IY	11 111 101							S/D		2	14	IYL ← SP - 2 <sub>W</sub> IYH ← SP - 1 <sub>W</sub> SP <sub>H</sub> - 2 ← SP <sub>H</sub>	.	.	.	.	.	.
		11 100 101							S/D		2	14	IYL ← SP - 2 <sub>W</sub> IYH ← SP - 1 <sub>W</sub> SP <sub>H</sub> - 2 ← SP <sub>H</sub>	.	.	.	.	.	.
	POP	POP zz	11 zz0 001				D		S		1	9	SP + 1 <sub>W</sub> ← zzH SP <sub>H</sub> ← zzL SP <sub>H</sub> + 2 ← SP <sub>H</sub>	.	.	.	.	.	.
POP IX		11 011 101						S/D		2	12	(SP + 1 <sub>W</sub> ) ← IXH SP <sub>H</sub> ← IXL SP <sub>H</sub> + 2 ← SP <sub>H</sub>	.	.	.	.	.	.	
		11 100 001							S/D		2	12	(SP + 1 <sub>W</sub> ) ← IYH SP <sub>H</sub> ← IYL SP <sub>H</sub> + 2 ← SP <sub>H</sub>	.	.	.	.	.	.
POP IY		11 111 101							S/D		2	12	(SP + 1 <sub>W</sub> ) ← IYH SP <sub>H</sub> ← IYL SP <sub>H</sub> + 2 ← SP <sub>H</sub>	.	.	.	.	.	.
		11 100 001							S/D		2	12	(SP + 1 <sub>W</sub> ) ← IYH SP <sub>H</sub> ← IYL SP <sub>H</sub> + 2 ← SP <sub>H</sub>	.	.	.	.	.	.
Exchange		EX AF,AF'	00 001 000						S/D		1	4	AF <sub>H</sub> ← AF <sub>H</sub> ' AF <sub>L</sub> ← AF <sub>L</sub> '	.	.	.	.	.	.
	EX DE,HL	11 101 011						S/D		1	3	DE <sub>H</sub> ← HL <sub>H</sub> DE <sub>L</sub> ← HL <sub>L</sub>	.	.	.	.	.	.	
	EXX	11 011 001							S/D		1	3	BC <sub>H</sub> ← BC <sub>H</sub> ' BC <sub>L</sub> ← BC <sub>L</sub> '	.	.	.	.	.	.
		11 100 011							S/D		1	3	DE <sub>H</sub> ← DE <sub>H</sub> ' DE <sub>L</sub> ← DE <sub>L</sub> '	.	.	.	.	.	.
	EX (SP),HL	11 100 011						S/D		1	16	H <sub>H</sub> ← SP + 1 <sub>W</sub> H <sub>L</sub> ← SP <sub>H</sub>	.	.	.	.	.	.	
	EX (SP),IX	11 011 101							S/D		2	19	IXH ← SP + 1 <sub>W</sub> IXL ← SP <sub>H</sub>	.	.	.	.	.	.
		11 100 011							S/D		2	19	IXH ← SP + 1 <sub>W</sub> IXL ← SP <sub>H</sub>	.	.	.	.	.	.
	EX (SP),IY	11 111 101							S/D		2	19	IYH ← SP + 1 <sub>W</sub> IYL ← SP <sub>H</sub>	.	.	.	.	.	.
11 100 011								S/D		2	19	IYH ← SP + 1 <sub>W</sub> IYL ← SP <sub>H</sub>	.	.	.	.	.	.	



# HD64180R/Z

Operation name	MNEMONICS	OP-code	Addressing								Bytes	Status	Operation	Flag					
			IMMED	EXT	IND	REG	REGI	IMP	REL	7				6	4	2	1	0	
																			S
Restart	RST v	11 v 111							D		1	11	PCH ← SP - 1 <sub>H</sub> PCL ← SP - 2 <sub>H</sub> 0 ← PCH v ← PCL SP <sub>H</sub> ← Z ← SP <sub>L</sub>	.	.	.	.	.	.

## I/O Instructions

Operation name	MNEMONICS	OP-code	Addressing								Bytes	Status	Operation	Flag							
			IMMED	EXT	IND	REG	REGI	IMP	IO	7				6	4	2	1	0			
																			S	Z	H
INPUT	IN A,(m)	11 011 011 < m >							D	S	2	9	(Am) <sub>1</sub> ← Ar m ← A <sub>0</sub> ← Ar	.	.	.	.	.	.		
	IN g,(C)	11 101 101 01 g 000						D		S	2	9	(BC) <sub>1</sub> ← gr g = 110. Only the flags will change. C ← A <sub>0</sub> ← Ar Br ← A <sub>4</sub> ← A <sub>15</sub>	[	]	R	P	R	.		
	INO g,(m)	11 101 101 00 g 000 < m >						D		S	3	12	(00m) <sub>1</sub> ← gr g = 110. Only the flags will change. m ← A <sub>0</sub> ← Ar OO ← A <sub>4</sub> ← A <sub>15</sub>	[	]	R	P	R	.		
	IND	11 101 101 10 101 010							D		S	2	12	(BC) <sub>1</sub> ← HL <sub>16</sub> HL <sub>1</sub> ← HL <sub>16</sub> Br ← 1 ← Br C ← A <sub>0</sub> ← Ar Br ← A <sub>4</sub> ← A <sub>15</sub>	X	[	X	X	X		X
	INDR	11 101 101 10 111 010							D		S	2	14Br ≠ 0 12Br = 0	(BC) <sub>1</sub> ← HL <sub>16</sub> Q HL <sub>1</sub> ← 1 ← HL <sub>16</sub> Br ← 1 ← Br Repeat Q until Br = 0 C ← A <sub>0</sub> ← Ar Br ← A <sub>4</sub> ← A <sub>15</sub>	X	S	X	X	X		X
	INI	11 101 101 10 100 010							D		S	2	12	(BC) <sub>1</sub> ← HL <sub>16</sub> HL <sub>1</sub> + 1 ← HL <sub>16</sub> Br ← 1 ← Br C ← A <sub>0</sub> ← Ar Br ← A <sub>4</sub> ← A <sub>15</sub>	X	[	X	X	X		X
	INR	11 101 101 10 110 010							D		S	2	14Br ≠ 0 12Br = 0	(BC) <sub>1</sub> ← HL <sub>16</sub> Q HL <sub>1</sub> + 1 ← HL <sub>16</sub> Br ← 1 ← Br Repeat Q until Br = 0 C ← A <sub>0</sub> ← Ar Br ← A <sub>4</sub> ← A <sub>15</sub>	X	S	X	X	X		X

(to be continued)

- ③ Z = 1 : Br = 1 = 0  
Z = 0 : Br = 1 ≠ 0
- ④ N = 1 : MSB of Data = 1  
N = 0 : MSB of Data = 0



Operation name	MNEMONICS	OP-code	Addressing						Bytes	States	Operation	Flag							
			IMMED	EXT	IND	REG	REGI	RMP				IO	7	6	4	2	1	0	
													S	Z	H	P/V	N	C	
OUTPUT	OUT ImJA	11 010 011 < m >						S	D	2	10	Ar ← (Am) m ← Ao ← Ar Ar ← As ← A15	.	.	.	.	.	.	
	OUT (C)g	11 101 101 01 g 001					S		D	2	10	gr ← (BC) Cr ← Ao ← Ar Br ← As ← A15	.	.	.	.	.	.	
	OUTO ImJg	11 101 101 00 g 001 < m >					S		D	3	13	gr ← (OOm) m ← Ao ← Ar OO ← As ← A15	.	.	.	.	.	.	
	OTDM	11 101 101 10 001 011						S		D	2	14	HLN ← (OOCh) HLN ← 1 ← HLN Cr ← 1 ← Cr Br ← 1 ← Br Cr ← Ao ← Ar OO ← As ← A15	③			④		
	OTDMR	11 101 101 10 011 011						S		D	2	16Br ≠ 0 14Br = 0	HLN ← (OOCh) Q HLN ← 1 ← HLN Cr ← 1 ← Cr Br ← 1 ← Br Repeat Q until Br = 0 Cr ← Ao ← Ar OO ← As ← A15	R	S	R	S	I	R
	OTDR	11 101 101 10 111 011						S		D	2	14Br ≠ 0 12Br = 0	HLN ← (BC) Q HLN ← 1 ← HLN Br ← 1 ← Br Repeat Q until Br = 0 Cr ← Ao ← Ar Br ← As ← A15	X	S	X	X	I	X
	OUTI	11 101 101 10 100 011						S		D	2	12	HLN ← (BC) HLN ← 1 ← HLN Br ← 1 ← Br Cr ← Ao ← Ar Br ← As ← A15	X	I	X	X	I	X
	OTR	11 101 101 10 110 011						S		D	2	14Br ≠ 0 12Br = 0	HLN ← (BC) Q HLN ← 1 ← HLN Br ← 1 ← Br Repeat Q until Br = 0 Cr ← Ao ← Ar Br ← As ← A15	X	S	X	X	I	X
	TSTIO m	11 101 101 01 110 100 < m >	S						S	3	12	(OOCh) ← m Cr ← Ao ← Ar OO ← As ← A15	I	I	S	P	R	R	

(to be continued)

- ③ Z=1: Br=1=0  
Z=0: Br=1≠0
- ④ N=1: MSB of Data=1  
N=0: MSB of Data=0





20 INSTRUCTION SUMMARY IN ALPHABETICAL ORDER

MNEMONICS	Bytes	Machine Cycles	States
ADC A,m	2	2	6
ADC A,g	1	2	4
ADC A, (HL)	1	2	6
ADC A, (X+d)	3	6	14
ADC A, (Y+d)	3	6	14
ADD A,m	2	2	6
ADD A,g	1	2	4
ADD A, (HL)	1	2	6
ADD A, (X+d)	3	6	14
ADD A, (Y+d)	3	6	14
ADC HL,ww	2	6	10
ADD HL,ww	1	5	7
ADD IX,xx	2	6	10
ADD IY,yy	2	6	10
AND m	2	2	6
AND g	1	2	4
AND (HL)	1	2	6
AND (X+d)	3	6	14
AND (Y+d)	3	6	14
BIT b, (HL)	2	3	9
BIT b, (X+d)	4	5	15
BIT b, (Y+d)	4	5	15
BIT b,g	2	2	6
CALL f,mn	3	2	6
			(If condition is false)
	3	6	16
			(If condition is true)

(to be continued)

MNEMONICS	Bytes	Machine Cycles	States
CALL mn	3	6	16
CCF	1	1	3
CPD	2	6	12
CPDR	2	8	14
			(if $BC_R \neq 0$ and $Ar \neq (HL)_M$ )
	2	6	12
			(if $BC_R = 0$ or $Ar = (HL)_M$ )
CP (HL)	1	2	6
CPI	2	6	12
CPIR	2	8	14
			(if $BC_R \neq 0$ and $Ar \neq (HL)_M$ )
	2	6	12
			(if $BC_R = 0$ or $Ar = (HL)_M$ )
CP (IX+d)	3	6	14
CP (Y+d)	3	6	14
CPL	1	1	3
CP m	2	2	6
CP g	1	2	4
DAA	1	2	4
DEC (HL)	1	4	10
DEC IX	2	3	7
DEC IY	2	3	7
DEC (IX+d)	3	8	18
DEC (Y+d)	3	8	18
DEC g	1	2	4
DEC ww	1	2	4
DI	1	1	3

(to be continued)

MNEMONICS	Bytes	Machine Cycles	States
DJNZ j	2	5	9 (If Br≠0)
	2	3	7 (If Br=0)
EI	1	1	3
EX AF,AF'	1	2	4
EX DE,HL	1	1	3
EX (SP),HL	1	6	16
EX (SP),IX	2	7	19
EX (SP),IY	2	7	19
EXX	1	1	3
HALT	1	1	3
IM 0	2	2	6
IM 1	2	2	6
IM 2	2	2	6
INC g	1	2	4
INC (HL)	1	4	10
INC (X+d)	3	8	18
INC (Y+d)	3	8	18
INC ww	1	2	4
INC IX	2	3	7
INC IY	2	3	7
IN A,(m)	2	3	9
IN g,(C)	2	3	9
INI	2	4	12
INIR	2	6	14 (If Br≠0)
	2	4	12 (If Br=0)
IND	2	4	12
INDR	2	6	14 (If Br≠0)

(to be continued)

MNEMONICS	Bytes	Machine Cycles	States
INDR	2	4	12 (if Br=0)
INO g,(m)	3	4	12
JP f,mn	3	2	6
			(if f is false)
	3	3	9
			(if f is true)
JP (HL)	1	1	3
JP (IX)	2	2	6
JP (IY)	2	2	6
JP mn	3	3	9
JR j	2	4	8
JR C,j	2	2	6
			(if condition is false)
	2	4	8
			(if condition is true)
JR NC,j	2	2	6
			(if condition is false)
	2	4	8
			(if condition is true)
JR Z,j	2	2	6
			(if condition is false)
	2	4	8
			(if condition is true)
JR NZ,j	2	2	6
			(if condition is false)
	2	4	8
			(if condition is true)

(to be continued)

MNEMONICS	Bytes	Machine Cycles	States
LD A, (BC)	1	2	6
LD A, (DE)	1	2	6
LD A,I	2	2	6
LD A, (mn)	3	4	12
LD A,R	2	2	6
LD (BC),A	1	3	7
LDD	2	4	12
LD (DE),A	1	3	7
LD ww,mn	3	3	9
LD ww,(mn)	4	6	18
LDDR	2	6	14 (if $BC_R \neq 0$ )
	2	4	12 (if $BC_R = 0$ )
LD (HL),m	2	3	9
LD HL,(mn)	3	5	15
LD (HL),g	1	3	7
LDI	2	4	12
LD I,A	2	2	6
LDIR	2	6	14 (if $BC_R \neq 0$ )
	2	4	12 (if $BC_R = 0$ )
LD IX,mn	4	4	12
LD IX,(mn)	4	6	18
LD (IX+d),m	4	5	15
LD (IX+d),g	3	7	15
LD IY,mn	4	4	12
LD IY,(mn)	4	6	18
LD (IY+d),m	4	5	15
LD (IY+d),g	3	7	15

(to be continued)

---

**HD64180R/Z**

---

MNEMONICS	Bytes	Machine Cycles	States
LD (mn),A	3	5	13
LD (mn),ww	4	7	19
LD (mn),HL	3	6	16
LD (mn),IX	4	7	19
LD (mn),IY	4	7	19
LD R,A	2	2	6
LD g,(HL)	1	2	6
LD g,(IX+d)	3	6	14
LD g,(IY+d)	3	6	14
LD g,m	2	2	6
LD g,g'	1	2	4
LD SP,HL	1	2	4
LD SP,IX	2	3	7
LD SP,IY	2	3	7
MLT ww	2	13	17
NEG	2	2	6
NOP	1	1	3
OR (HL)	1	2	6
OR (IX+d)	3	6	14
OR (IY+d)	3	6	14
OR m	2	2	6
OR g	1	2	4
OTDM	2	6	14
OTDMR	2	8	16 (if Br≠0)
	2	6	14 (if Br=0)
OTDR	2	6	14 (if Br≠0)
	2	4	12 (if Br=0)

(to be continued)



MNEMONICS	Bytes	Machine Cycles	States
OTIM	2	6	14
OTIMR	2	8	16 (If Br≠0)
	2	6	14 (If Br=0)
OTIR	2	6	14 (If Br≠0)
	2	4	12 (If Br=0)
OUTD	2	4	12
OUTI	2	4	12
OUT (m),A	2	4	10
OUT (C),g	2	4	10
OUTO (m),g	3	5	13
POP IX	2	4	12
POP IY	2	4	12
POP zz	1	3	9
PUSH IX	2	6	14
PUSH IY	2	6	14
PUSH zz	1	5	11
RES b,(HL)	2	5	13
RES b,(IX+d)	4	7	19
RES b,(IY+d)	4	7	19
RES b,g	2	3	7
RET	1	3	9
RET f	1	3	5
			(If condition is false)
	1	4	10
			(If condition is true)
RETI	2	4	12
RETN	2	4	12

(to be continued)

HD64180R/Z

MNEMONICS	Bytes	Machine Cycles	States
RLA	1	1	3
RLCA	1	1	3
RLC (HL)	2	5	13
RLC (IX+d)	4	7	19
RLC (IY+d)	4	7	19
RLC g	2	3	7
RLD	2	8	16
RL (HL)	2	5	13
RL (IX+d)	4	7	19
RL (IY+d)	4	7	19
RL g	2	3	7
RRA	1	1	3
RRCA	1	1	3
RRC (HL)	2	5	13
RRC (IX+d)	4	7	19
RRC (IY+d)	4	7	19
RRC g	2	3	7
RRD	2	8	16
RR (HL)	2	5	13
RR (IX+d)	4	7	19
RR (IY+d)	4	7	19
RR g	2	3	7
RST v	1	5	11
SBC A,(HL)	1	2	6
SBC A,(IX+d)	3	6	14
SBC A,(IY+d)	3	6	14
SBC A,m	2	2	6

(to be continued)

MNEMONICS	Bytes	Machine Cycles	States
SBC A,g	1	2	4
SBC HL,ww	2	6	10
SCF	1	1	3
SET b,(HL)	2	5	13
SET b,(IX+d)	4	7	19
SET b,(IY+d)	4	7	19
SET b,g	2	3	7
SLA (HL)	2	5	13
SLA (IX+d)	4	7	19
SLA (IY+d)	4	7	19
SLA g	2	3	7
SLP	2	2	8
SRA (HL)	2	5	13
SRA (IX+d)	4	7	19
SRA (IY+d)	4	7	19
SRA g	2	3	7
SRL (HL)	2	5	13
SRL (IX+d)	4	7	19
SRL (IY+d)	4	7	19
SRL g	2	3	7
SUB (HL)	1	2	6
SUB (IX+d)	3	6	14
SUB (IY+d)	3	6	14
SUB m	2	2	6
SUB g	1	2	4
TSTIO m	3	4	12
TST g	2	3	7

(to be continued)

---

**HD64180R/Z**

---

<b>MNEMONICS</b>	<b>Bytes</b>	<b>Machine Cycles</b>	<b>States</b>
TST m	3	3	9
TST (HL)	2	4	10
XOR (HL)	1	2	6
XOR (IX+d)	3	6	14
XOR (IY+d)	3	6	14
XOR m	2	2	6
XOR g	1	2	4



Table 19 2nd op-code map  
Instruction format : CB XX

		b (LO=0~7)															
		0	1	2	3	4	5	6	7	8	9	A	B	C	D	E	F
L	B 0000	0	0	0	0	0	0	0	0	0	0	0	0	0	0	0	0
	C 0001	0	0	0	0	0	0	0	0	0	0	0	0	0	0	0	0
D 0010	0	0	0	0	0	0	0	0	0	0	0	0	0	0	0	0	0
E 0011	0	0	0	0	0	0	0	0	0	0	0	0	0	0	0	0	0
H 0100	0	0	0	0	0	0	0	0	0	0	0	0	0	0	0	0	0
L 0101	0	0	0	0	0	0	0	0	0	0	0	0	0	0	0	0	0
(HL) 0110	0	0	0	0	0	0	0	0	0	0	0	0	0	0	0	0	0
A 0111	0	0	0	0	0	0	0	0	0	0	0	0	0	0	0	0	0
B 1000	0	0	0	0	0	0	0	0	0	0	0	0	0	0	0	0	0
C 1001	0	0	0	0	0	0	0	0	0	0	0	0	0	0	0	0	0
D 1010	0	0	0	0	0	0	0	0	0	0	0	0	0	0	0	0	0
E 1011	0	0	0	0	0	0	0	0	0	0	0	0	0	0	0	0	0
H 1100	0	0	0	0	0	0	0	0	0	0	0	0	0	0	0	0	0
L 1101	0	0	0	0	0	0	0	0	0	0	0	0	0	0	0	0	0
(HL) 1110	0	0	0	0	0	0	0	0	0	0	0	0	0	0	0	0	0
A 1111	0	0	0	0	0	0	0	0	0	0	0	0	0	0	0	0	0
		b (LO=8~F)															
		0	1	2	3	4	5	6	7	8	9	A	B	C	D	E	F
H	B 0000	0	0	0	0	0	0	0	0	0	0	0	0	0	0	0	0
	C 0001	0	0	0	0	0	0	0	0	0	0	0	0	0	0	0	0
D 0010	0	0	0	0	0	0	0	0	0	0	0	0	0	0	0	0	0
E 0011	0	0	0	0	0	0	0	0	0	0	0	0	0	0	0	0	0
H 0100	0	0	0	0	0	0	0	0	0	0	0	0	0	0	0	0	0
L 0101	0	0	0	0	0	0	0	0	0	0	0	0	0	0	0	0	0
(HL) 0110	0	0	0	0	0	0	0	0	0	0	0	0	0	0	0	0	0
A 0111	0	0	0	0	0	0	0	0	0	0	0	0	0	0	0	0	0
B 1000	0	0	0	0	0	0	0	0	0	0	0	0	0	0	0	0	0
C 1001	0	0	0	0	0	0	0	0	0	0	0	0	0	0	0	0	0
D 1010	0	0	0	0	0	0	0	0	0	0	0	0	0	0	0	0	0
E 1011	0	0	0	0	0	0	0	0	0	0	0	0	0	0	0	0	0
H 1100	0	0	0	0	0	0	0	0	0	0	0	0	0	0	0	0	0
L 1101	0	0	0	0	0	0	0	0	0	0	0	0	0	0	0	0	0
(HL) 1110	0	0	0	0	0	0	0	0	0	0	0	0	0	0	0	0	0
A 1111	0	0	0	0	0	0	0	0	0	0	0	0	0	0	0	0	0

NOTE1) If DDH is supplemented as 1st op-code for the instructions which have (HL) as operand in Table 19, the instructions are executed replacing (HL) with (IX+d).  
 If FDH is supplemented as 1st op-code for the instructions which have (HL) as operand in Table 19, the instructions are executed replacing (HL) with (IV+d).

Table 20 2nd op-code map  
Instruction format : ED XX

		g (LO=0~7)							ww (LO=ALL)									
		B	D	H	B	D	H	BC	DE	HL	SP							
HI	0000	0001	0100	0011	0100	0101	0110	0111	1000	1001	1010	1011	1100	1101	1110	1111		
LO	0	1	2	3	4	5	6	7	8	9	A	B	C	D	E	F		
0000	0	INO g, (m)		IN g, (C)				LDI LDIR										
0001	1	OUT0 (m),g		OUT (C),g				CPI CPIR										
0010	2			SBC HL, ww				INI INIR										
0011	3			LD (m), ww				OTIM OTIMR OUTI OTIR										
0100	4	TST g	TST (M)	NEG				TST m TST0 m										
0101	5			RETN														
0110	6			IM 0 IM 1				SLP										
0111	7			LD,LA				LD A, I RRD										
1000	8	INO g, (m)		IN g, (C)				LDD LDDR										
1001	9	OUT0 (m),g		OUT (C),g				OPD OPDR										
1010	A			ADC HL, ww				IND INDR										
1011	B			LD ww, (m)				OTDM OTDMR OUTD OTDR										
1100	C	TST g		MLT ww														
1101	D			RETI														
1110	E			IM 2														
1111	F			LD RA, LD AR, RLD														
	0	1	2	3	4	5	6	7	8	9	A	B	C	D	E	F		
	C	E	L	A	C	E	L	A										
	g (LO=8~F)																	

# HD64180R/Z

## 22 BUS AND CONTROL SIGNAL CONDITION IN EACH MACHINE CYCLE

\* (ADDRESS) : invalid  
Z (DATA) : high impedance.

Instruction	Machine Cycle	States	ADDRESS	DATA	$\overline{RD}$	$\overline{WR}$	$\overline{ME}$	$\overline{IOE}$	$\overline{LIR}$	$\overline{HALT}$	ST
ADD HL,ww	MC <sub>1</sub>	T <sub>1</sub> T <sub>2</sub> T <sub>3</sub>	1st op-code Address	1st op-code	0	1	0	1	0	1	0
	MC <sub>2</sub> ~MC <sub>3</sub>	TITITIT <sub>1</sub>	*	Z	1	1	1	1	1	1	1
ADD IX,xx ADD IY,yy	MC <sub>1</sub>	T <sub>1</sub> T <sub>2</sub> T <sub>3</sub>	1st op-code Address	1st op-code	0	1	0	1	0	1	0
	MC <sub>2</sub>	T <sub>1</sub> T <sub>2</sub> T <sub>3</sub>	2nd op-code Address	2nd op-code	0	1	0	1	0	1	1
	MC <sub>3</sub> ~MC <sub>6</sub>	TITITIT <sub>1</sub>	*	Z	1	1	1	1	1	1	1
ADC HL,ww SBC HL,ww	MC <sub>1</sub>	T <sub>1</sub> T <sub>2</sub> T <sub>3</sub>	1st op-code Address	1st op-code	0	1	0	1	0	1	0
	MC <sub>2</sub>	T <sub>1</sub> T <sub>2</sub> T <sub>3</sub>	2nd op-code Address	2nd op-code	0	1	0	1	0	1	1
	MC <sub>3</sub> ~MC <sub>6</sub>	TITITIT <sub>1</sub>	*	Z	1	1	1	1	1	1	1
ADD A,g ADC A,g SUB g SBC A,g AND g OR g XOR g CP g	MC <sub>1</sub>	T <sub>1</sub> T <sub>2</sub> T <sub>3</sub>	1st op-code Address	1st op-code	0	1	0	1	0	1	0
	MC <sub>2</sub>	T <sub>1</sub>	*	Z	1	1	1	1	1	1	1
ADD A,m ADC A,m SUB m SBC A,m AND m OR m XOR m CP m	MC <sub>1</sub>	T <sub>1</sub> T <sub>2</sub> T <sub>3</sub>	1st op-code Address	1st op-code	0	1	0	1	0	1	0
	MC <sub>2</sub>	T <sub>1</sub> T <sub>2</sub> T <sub>3</sub>	1st operand Address	m	0	1	0	1	1	1	1
ADD A, (HL) ADC A, (HL) SUB (HL) SBC A, (HL) AND (HL) OR (HL) XOR (HL) CP (HL)	MC <sub>1</sub>	T <sub>1</sub> T <sub>2</sub> T <sub>3</sub>	1st op-code Address	1st op-code	0	1	0	1	0	1	0
	MC <sub>2</sub>	T <sub>1</sub> T <sub>2</sub> T <sub>3</sub>	HL	DATA	0	1	0	1	1	1	1
ADD A, (X+d) ADD A, (Y+d) ADC A, (X+d) ADC A, (Y+d) SUB (X+d) SUB (Y+d) SBC A, (X+d)	MC <sub>1</sub>	T <sub>1</sub> T <sub>2</sub> T <sub>3</sub>	1st op-code Address	1st op-code	0	1	0	1	0	1	0
	MC <sub>2</sub>	T <sub>1</sub> T <sub>2</sub> T <sub>3</sub>	2nd op-code Address	2nd op-code	0	1	0	1	0	1	1

(to be continued)



Instruction	Machine Cycle	States	ADDRESS	DATA	$\overline{RD}$	$\overline{WR}$	$\overline{ME}$	$\overline{IOE}$	$\overline{LIR}$	HALT	ST
SBC A, (Y+d) AND (X+d) AND (Y+d) OR (X+d) OR (Y+d) XOR (X+d) XOR (Y+d) CP (X+d) CP (Y+d)	MC <sub>3</sub>	T <sub>1</sub> T <sub>2</sub> T <sub>3</sub>	1st operand Address	d	0	1	0	1	1	1	1
	MC <sub>4</sub> ~MC <sub>5</sub>	TiTi	.	Z	1	1	1	1	1	1	1
	MC <sub>6</sub>	T <sub>1</sub> T <sub>2</sub> T <sub>3</sub>	IX+d Y+d	DATA	0	1	0	1	1	1	1
BIT b,g	MC <sub>1</sub>	T <sub>1</sub> T <sub>2</sub> T <sub>3</sub>	1st op-code Address	1st op-code	0	1	0	1	0	1	0
	MC <sub>2</sub>	T <sub>1</sub> T <sub>2</sub> T <sub>3</sub>	2nd op-code Address	2nd op-code	0	1	0	1	0	1	1
BIT b, (HL)	MC <sub>1</sub>	T <sub>1</sub> T <sub>2</sub> T <sub>3</sub>	1st op-code Address	1st op-code	0	1	0	1	0	1	0
	MC <sub>2</sub>	T <sub>1</sub> T <sub>2</sub> T <sub>3</sub>	2nd op-code Address	2nd op-code	0	1	0	1	0	1	1
	MC <sub>3</sub>	T <sub>1</sub> T <sub>2</sub> T <sub>3</sub>	HL	DATA	0	1	0	1	1	1	1
BIT b, (X+d) BIT b, (Y+d)	MC <sub>1</sub>	T <sub>1</sub> T <sub>2</sub> T <sub>3</sub>	1st op-code Address	1st op-code	0	1	0	1	0	1	0
	MC <sub>2</sub>	T <sub>1</sub> T <sub>2</sub> T <sub>3</sub>	2nd op-code Address	2nd op-code	0	1	0	1	0	1	1
	MC <sub>3</sub>	T <sub>1</sub> T <sub>2</sub> T <sub>3</sub>	1st operand Address	d	0	1	0	1	1	1	1
	MC <sub>4</sub>	T <sub>1</sub> T <sub>2</sub> T <sub>3</sub>	3rd op-code Address	3rd op-code	0	1	0	1	0	1	1
	MC <sub>5</sub>	T <sub>1</sub> T <sub>2</sub> T <sub>3</sub>	IX+d Y+d	DATA	0	1	0	1	1	1	1
CALL mn	MC <sub>1</sub>	T <sub>1</sub> T <sub>2</sub> T <sub>3</sub>	1st op-code Address	1st op-code	0	1	0	1	0	1	0
	MC <sub>2</sub>	T <sub>1</sub> T <sub>2</sub> T <sub>3</sub>	1st operand Address	n	0	1	0	1	1	1	1
	MC <sub>3</sub>	T <sub>1</sub> T <sub>2</sub> T <sub>3</sub>	2nd operand Address	m	0	1	0	1	1	1	1
	MC <sub>4</sub>	Ti	.	Z	1	1	1	1	1	1	1
	MC <sub>5</sub>	T <sub>1</sub> T <sub>2</sub> T <sub>3</sub>	SP-1	PCH	1	0	0	1	1	1	1
	MC <sub>6</sub>	T <sub>1</sub> T <sub>2</sub> T <sub>3</sub>	SP-2	PCL	1	0	0	1	1	1	1
CALL f,mn (f condition is false)	MC <sub>1</sub>	T <sub>1</sub> T <sub>2</sub> T <sub>3</sub>	1st op-code Address	1st op-code	0	1	0	1	0	1	0
	MC <sub>2</sub>	T <sub>1</sub> T <sub>2</sub> T <sub>3</sub>	1st operand Address	n	0	1	0	1	1	1	1

(to be continued)

# HD64180R/Z

Instruction	Machine Cycle	States	ADDRESS	DATA	$\overline{RD}$	$\overline{WR}$	$\overline{ME}$	$\overline{IOE}$	$\overline{LIR}$	$\overline{HALT}$	ST
CALL f,mn (if condition is true)	MC <sub>1</sub>	T <sub>1</sub> T <sub>2</sub> T <sub>3</sub>	1st op-code Address	1st op-code	0	1	0	1	0	1	0
	MC <sub>2</sub>	T <sub>1</sub> T <sub>2</sub> T <sub>3</sub>	1st operand Address	n	0	1	0	1	1	1	1
	MC <sub>3</sub>	T <sub>1</sub> T <sub>2</sub> T <sub>3</sub>	2nd operand Address	m	0	1	0	1	1	1	1
	MC <sub>4</sub>	T <sub>i</sub>	*	Z	1	1	1	1	1	1	1
	MC <sub>5</sub>	T <sub>1</sub> T <sub>2</sub> T <sub>3</sub>	SP-1	PCH	1	0	0	1	1	1	1
	MC <sub>6</sub>	T <sub>1</sub> T <sub>2</sub> T <sub>3</sub>	SP-2	PCL	1	0	0	1	1	1	1
CCF	MC <sub>1</sub>	T <sub>1</sub> T <sub>2</sub> T <sub>3</sub>	1st op-code Address	1st op-code	0	1	0	1	0	1	0
CPI CPD	MC <sub>1</sub>	T <sub>1</sub> T <sub>2</sub> T <sub>3</sub>	1st op-code Address	1st op-code	0	1	0	1	0	1	0
	MC <sub>2</sub>	T <sub>1</sub> T <sub>2</sub> T <sub>3</sub>	2nd op-code Address	2nd op-code	0	1	0	1	0	1	1
	MC <sub>3</sub>	T <sub>1</sub> T <sub>2</sub> T <sub>3</sub>	HL	DATA	0	1	0	1	1	1	1
	MC <sub>4</sub> ~MC <sub>6</sub>	T <sub>i</sub> T <sub>i</sub> T <sub>i</sub> T <sub>i</sub>	*	Z	1	1	1	1	1	1	1
CPIR CPDR (if BC <sub>n</sub> ≠0 and Ar≠(HL) <sub>w</sub> )	MC <sub>1</sub>	T <sub>1</sub> T <sub>2</sub> T <sub>3</sub>	1st op-code Address	1st op-code	0	1	0	1	0	1	0
	MC <sub>2</sub>	T <sub>1</sub> T <sub>2</sub> T <sub>3</sub>	2nd op-code Address	2nd op-code	0	1	0	1	0	1	1
	MC <sub>3</sub>	T <sub>1</sub> T <sub>2</sub> T <sub>3</sub>	HL	DATA	0	1	0	1	1	1	1
	MC <sub>4</sub> ~MC <sub>6</sub>	T <sub>i</sub> T <sub>i</sub> T <sub>i</sub> T <sub>i</sub> T <sub>i</sub>	*	Z	1	1	1	1	1	1	1
CPIR CPDR (if BC <sub>n</sub> =0 or Ar=(HL) <sub>w</sub> )	MC <sub>1</sub>	T <sub>1</sub> T <sub>2</sub> T <sub>3</sub>	1st op-code Address	1st op-code	0	1	0	1	0	1	0
	MC <sub>2</sub>	T <sub>1</sub> T <sub>2</sub> T <sub>3</sub>	2nd op-code Address	2nd op-code	0	1	0	1	0	1	1
	MC <sub>3</sub>	T <sub>1</sub> T <sub>2</sub> T <sub>3</sub>	HL	DATA	0	1	0	1	1	1	1
	MC <sub>4</sub> ~MC <sub>6</sub>	T <sub>i</sub> T <sub>i</sub> T <sub>i</sub> T <sub>i</sub>	*	Z	1	1	1	1	1	1	1
CPL	MC <sub>1</sub>	T <sub>1</sub> T <sub>2</sub> T <sub>3</sub>	1st op-code Address	1st op-code	0	1	0	1	0	1	0
DAA	MC <sub>1</sub>	T <sub>1</sub> T <sub>2</sub> T <sub>3</sub>	1st op-code Address	1st op-code	0	1	0	1	0	1	0
	MC <sub>2</sub>	T <sub>i</sub>	*	Z	1	1	1	1	1	1	1
DI	MC <sub>1</sub>	T <sub>1</sub> T <sub>2</sub> T <sub>3</sub>	1st op-code Address	1st op-code	0	1	0	1	0	1	0

(to be continued)

Instruction	Machine Cycle	States	ADDRESS	DATA	$\overline{RD}$	$\overline{WR}$	$\overline{ME}$	$\overline{IOE}$	$\overline{LIR}$	$\overline{HALT}$	ST
DJNZ j (If Br≠0)	MC <sub>1</sub>	T <sub>1</sub> T <sub>2</sub> T <sub>3</sub>	1st op-code Address	1st op-code	0	1	0	1	0	1	0
	MC <sub>2</sub>	T <sub>i</sub> *1	*	Z	1	1	1	1	1	1	1
	MC <sub>3</sub>	T <sub>1</sub> T <sub>2</sub> T <sub>3</sub>	1st operand Address	j-2	0	1	0	1	1	1	1
	MC <sub>4</sub> ~MC <sub>5</sub>	TiT <sub>i</sub>	*	Z	1	1	1	1	1	1	1
DJNZ j (If Br=0)	MC <sub>1</sub>	T <sub>1</sub> T <sub>2</sub> T <sub>3</sub>	1st op-code Address	1st op-code	0	1	0	1	0	1	0
	MC <sub>2</sub>	T <sub>i</sub> *1	*	Z	1	1	1	1	1	1	1
	MC <sub>3</sub>	T <sub>1</sub> T <sub>2</sub> T <sub>3</sub>	1st operand Address	j-2	0	1	0	1	1	1	1
EI	MC <sub>1</sub>	T <sub>1</sub> T <sub>2</sub> T <sub>3</sub>	1st op-code Address	1st op-code	0	1	0	1	0	1	0
EX DE, HL EXX	MC <sub>1</sub>	T <sub>1</sub> T <sub>2</sub> T <sub>3</sub>	1st op-code Address	1st op-code	0	1	0	1	0	1	0
EX AF, AF'	MC <sub>1</sub>	T <sub>1</sub> T <sub>2</sub> T <sub>3</sub>	1st op-code Address	1st op-code	0	1	0	1	0	1	0
	MC <sub>2</sub>	T <sub>i</sub>	*	Z	1	1	1	1	1	1	1
EX (SP), HL	MC <sub>1</sub>	T <sub>1</sub> T <sub>2</sub> T <sub>3</sub>	1st op-code Address	1st op-code	0	1	0	1	0	1	0
	MC <sub>2</sub>	T <sub>1</sub> T <sub>2</sub> T <sub>3</sub>	SP	DATA	0	1	0	1	1	1	1
	MC <sub>3</sub>	T <sub>1</sub> T <sub>2</sub> T <sub>3</sub>	SP+1	DATA	0	1	0	1	1	1	1
	MC <sub>4</sub>	T <sub>i</sub>	*	Z	1	1	1	1	1	1	1
	MC <sub>5</sub>	T <sub>1</sub> T <sub>2</sub> T <sub>3</sub>	SP+1	H	1	0	0	1	1	1	1
	MC <sub>6</sub>	T <sub>1</sub> T <sub>2</sub> T <sub>3</sub>	SP	L	1	0	0	1	1	1	1
EX (SP),IX EX (SP),IY	MC <sub>1</sub>	T <sub>1</sub> T <sub>2</sub> T <sub>3</sub>	1st op-code Address	1st op-code	0	1	0	1	0	1	0
	MC <sub>2</sub>	T <sub>1</sub> T <sub>2</sub> T <sub>3</sub>	2nd op-code Address	2nd op-code	0	1	0	1	0	1	1
	MC <sub>3</sub>	T <sub>1</sub> T <sub>2</sub> T <sub>3</sub>	SP	DATA	0	1	0	1	1	1	1
	MC <sub>4</sub>	T <sub>1</sub> T <sub>2</sub> T <sub>3</sub>	SP+1	DATA	0	1	0	1	1	1	1
	MC <sub>5</sub>	T <sub>i</sub>	*	Z	1	1	1	1	1	1	1

\*1 DMA, REFRESH, or BUS RELEASE cannot be executed after this state. (Request is ignored)

(to be continued)

Instruction	Machine Cycle	States	ADDRESS	DATA	$\overline{RD}$	$\overline{WR}$	$\overline{ME}$	$\overline{OE}$	$\overline{LR}$	$\overline{HALT}$	ST
EX (SP), IX EX (SP), IY	MC <sub>6</sub>	T <sub>1</sub> T <sub>2</sub> T <sub>3</sub>	SP+1	IXH IYH	1	0	0	1	1	1	1
	MC <sub>7</sub>	T <sub>1</sub> T <sub>2</sub> T <sub>3</sub>	SP	IXL IYL	1	0	0	1	1	1	1
HALT	MC <sub>1</sub>	T <sub>1</sub> T <sub>2</sub> T <sub>3</sub>	1st op-code Address	1st op-code	0	1	0	1	0	1	0
	—	—	Next op-code Address	Next op-code	0	1	0	1	0	0	0
IM 0 IM 1 IM 2	MC <sub>1</sub>	T <sub>1</sub> T <sub>2</sub> T <sub>3</sub>	1st op-code Address	1st op-code	0	1	0	1	0	1	0
	MC <sub>2</sub>	T <sub>1</sub> T <sub>2</sub> T <sub>3</sub>	2nd op-code Address	2nd op-code	0	1	0	1	0	1	1
INC g DEC g	MC <sub>1</sub>	T <sub>1</sub> T <sub>2</sub> T <sub>3</sub>	1st op-code Address	1st op-code	0	1	0	1	0	1	0
	MC <sub>2</sub>	T <sub>i</sub>	.	Z	1	1	1	1	1	1	1
INC (HL) DEC (HL)	MC <sub>1</sub>	T <sub>1</sub> T <sub>2</sub> T <sub>3</sub>	1st op-code Address	1st op-code	0	1	0	1	0	1	0
	MC <sub>2</sub>	T <sub>1</sub> T <sub>2</sub> T <sub>3</sub>	HL	DATA	0	1	0	1	1	1	1
	MC <sub>3</sub>	T <sub>i</sub>	.	Z	1	1	1	1	1	1	1
	MC <sub>4</sub>	T <sub>1</sub> T <sub>2</sub> T <sub>3</sub>	HL	DATA	1	0	0	1	1	1	1
INC (IX+d) INC (IY+d) DEC (IX+d) DEC (IY+d)	MC <sub>1</sub>	T <sub>1</sub> T <sub>2</sub> T <sub>3</sub>	1st op-code Address	1st op-code	0	1	0	1	0	1	0
	MC <sub>2</sub>	T <sub>1</sub> T <sub>2</sub> T <sub>3</sub>	2nd op-code Address	2nd op-code	0	1	0	1	0	1	1
	MC <sub>3</sub>	T <sub>1</sub> T <sub>2</sub> T <sub>3</sub>	1st operand Address	d	0	1	0	1	1	1	1
	MC <sub>4</sub> ~MC <sub>5</sub>	T <sub>i</sub> T <sub>i</sub>	.	Z	1	1	1	1	1	1	1
	MC <sub>6</sub>	T <sub>1</sub> T <sub>2</sub> T <sub>3</sub>	IX+d IY+d	DATA	0	1	0	1	1	1	1
	MC <sub>7</sub>	T <sub>i</sub>	.	Z	1	1	1	1	1	1	1
	MC <sub>8</sub>	T <sub>1</sub> T <sub>2</sub> T <sub>3</sub>	IX+d IY+d	DATA	1	0	0	1	1	1	1
INC ww DEC ww	MC <sub>1</sub>	T <sub>1</sub> T <sub>2</sub> T <sub>3</sub>	1st op-code Address	1st op-code	0	1	0	1	0	1	0
	MC <sub>2</sub>	T <sub>i</sub>	.	Z	1	1	1	1	1	1	1
INC IX INC IY DEC IX DEC IY	MC <sub>1</sub>	T <sub>1</sub> T <sub>2</sub> T <sub>3</sub>	1st op-code Address	1st op-code	0	1	0	1	0	1	0
	MC <sub>2</sub>	T <sub>1</sub> T <sub>2</sub> T <sub>3</sub>	2nd op-code Address	2nd op-code	0	1	0	1	0	1	1
	MC <sub>3</sub>	T <sub>i</sub>	.	Z	1	1	1	1	1	1	1

(to be continued)

Instruction	Machine Cycle	States	ADDRESS	DATA	$\overline{RD}$	$\overline{WR}$	$\overline{ME}$	$\overline{IOE}$	$\overline{LIR}$	$\overline{HALT}$	ST
IN A,(m)	MC <sub>1</sub>	T <sub>1</sub> T <sub>2</sub> T <sub>3</sub>	1st op-code Address	1st op-code	0	1	0	1	0	1	0
	MC <sub>2</sub>	T <sub>1</sub> T <sub>2</sub> T <sub>3</sub>	1st operand Address	m	0	1	0	1	1	1	1
	MC <sub>3</sub>	T <sub>1</sub> T <sub>2</sub> T <sub>3</sub>	m to A <sub>0</sub> ~A <sub>7</sub> A to A <sub>8</sub> ~A <sub>15</sub>	DATA	0	1	1	0	1	1	1
IN g,(C)	MC <sub>1</sub>	T <sub>1</sub> T <sub>2</sub> T <sub>3</sub>	1st op-code Address	1st op-code	0	1	0	1	0	1	0
	MC <sub>2</sub>	T <sub>1</sub> T <sub>2</sub> T <sub>3</sub>	2nd op-code Address	2nd op-code	0	1	0	1	0	1	1
	MC <sub>3</sub>	T <sub>1</sub> T <sub>2</sub> T <sub>3</sub>	BC	DATA	0	1	1	0	1	1	1
INO g,(m)	MC <sub>1</sub>	T <sub>1</sub> T <sub>2</sub> T <sub>3</sub>	1st op-code Address	1st op-code	0	1	0	1	0	1	0
	MC <sub>2</sub>	T <sub>1</sub> T <sub>2</sub> T <sub>3</sub>	2nd op-code Address	2nd op-code	0	1	0	1	0	1	1
	MC <sub>3</sub>	T <sub>1</sub> T <sub>2</sub> T <sub>3</sub>	1st operand Address	m	0	1	0	1	1	1	1
	MC <sub>4</sub>	T <sub>1</sub> T <sub>2</sub> T <sub>3</sub>	m to A <sub>0</sub> ~A <sub>7</sub> OOH to A <sub>8</sub> ~A <sub>15</sub>	DATA	0	1	1	0	1	1	1
INI IND	MC <sub>1</sub>	T <sub>1</sub> T <sub>2</sub> T <sub>3</sub>	1st op-code Address	1st op-code	0	1	0	1	0	1	0
	MC <sub>2</sub>	T <sub>1</sub> T <sub>2</sub> T <sub>3</sub>	2nd op-code Address	2nd op-code	0	1	0	1	0	1	1
	MC <sub>3</sub>	T <sub>1</sub> T <sub>2</sub> T <sub>3</sub>	BC	DATA	0	1	1	0	1	1	1
	MC <sub>4</sub>	T <sub>1</sub> T <sub>2</sub> T <sub>3</sub>	HL	DATA	1	0	0	1	1	1	1
INR INDR (If Br≠0)	MC <sub>1</sub>	T <sub>1</sub> T <sub>2</sub> T <sub>3</sub>	1st op-code Address	1st op-code	0	1	0	1	0	1	0
	MC <sub>2</sub>	T <sub>1</sub> T <sub>2</sub> T <sub>3</sub>	2nd op-code Address	2nd op-code	0	1	0	1	0	1	1
	MC <sub>3</sub>	T <sub>1</sub> T <sub>2</sub> T <sub>3</sub>	BC	DATA	0	1	1	0	1	1	1
	MC <sub>4</sub>	T <sub>1</sub> T <sub>2</sub> T <sub>3</sub>	HL	DATA	1	0	0	1	1	1	1
	MC <sub>5</sub> ~MC <sub>6</sub>	TiTi	.	Z	1	1	1	1	1	1	1
INR INDR (If Br=0)	MC <sub>1</sub>	T <sub>1</sub> T <sub>2</sub> T <sub>3</sub>	1st op-code Address	1st op-code	0	1	0	1	0	1	0
	MC <sub>2</sub>	T <sub>1</sub> T <sub>2</sub> T <sub>3</sub>	2nd op-code Address	2nd op-code	0	1	0	1	0	1	1
	MC <sub>3</sub>	T <sub>1</sub> T <sub>2</sub> T <sub>3</sub>	BC	DATA	0	1	1	0	1	1	1
	MC <sub>4</sub>	T <sub>1</sub> T <sub>2</sub> T <sub>3</sub>	HL	DATA	1	0	0	1	1	1	1

(to be continued)

Instruction	Machine Cycle	States	ADDRESS	DATA	$\overline{RD}$	$\overline{WR}$	$\overline{ME}$	$\overline{IOE}$	$\overline{LIR}$	$\overline{HALT}$	ST
JP mn	MC <sub>1</sub>	T <sub>1</sub> T <sub>2</sub> T <sub>3</sub>	1st op-code Address	1st op-code	0	1	0	1	0	1	0
	MC <sub>2</sub>	T <sub>1</sub> T <sub>2</sub> T <sub>3</sub>	1st operand Address	n	0	1	0	1	1	1	1
	MC <sub>3</sub>	T <sub>1</sub> T <sub>2</sub> T <sub>3</sub>	2nd operand Address	m	0	1	0	1	1	1	1
JP f,mn (If f is false)	MC <sub>1</sub>	T <sub>1</sub> T <sub>2</sub> T <sub>3</sub>	1st op-code Address	1st op-code	0	1	0	1	0	1	0
	MC <sub>2</sub>	T <sub>1</sub> T <sub>2</sub> T <sub>3</sub>	1st operand Address	n	0	1	0	1	1	1	1
JP f,mn (If f is true)	MC <sub>1</sub>	T <sub>1</sub> T <sub>2</sub> T <sub>3</sub>	1st op-code Address	1st op-code	0	1	0	1	0	1	0
	MC <sub>2</sub>	T <sub>1</sub> T <sub>2</sub> T <sub>3</sub>	1st operand Address	n	0	1	0	1	1	1	1
	MC <sub>3</sub>	T <sub>1</sub> T <sub>2</sub> T <sub>3</sub>	2nd operand Address	m	0	1	0	1	1	1	1
JP (HL)	MC <sub>1</sub>	T <sub>1</sub> T <sub>2</sub> T <sub>3</sub>	1st op-code Address	1st op-code	0	1	0	1	0	1	0
JP (DX) JP (Y)	MC <sub>1</sub>	T <sub>1</sub> T <sub>2</sub> T <sub>3</sub>	1st op-code Address	1st op-code	0	1	0	1	0	1	0
	MC <sub>2</sub>	T <sub>1</sub> T <sub>2</sub> T <sub>3</sub>	2nd op-code Address	2nd op-code	0	1	0	1	0	1	1
JR j	MC <sub>1</sub>	T <sub>1</sub> T <sub>2</sub> T <sub>3</sub>	1st op-code Address	1st op-code	0	1	0	1	0	1	0
	MC <sub>2</sub>	T <sub>1</sub> T <sub>2</sub> T <sub>3</sub>	1st operand Address	j-2	0	1	0	1	1	1	1
	MC <sub>3</sub> ~MC <sub>4</sub>	TiT <sub>i</sub>	*	Z	1	1	1	1	1	1	1
JR C <sub>j</sub> JR NC <sub>j</sub> JR Z <sub>j</sub> JR NZ <sub>j</sub> (If condition is false)	MC <sub>1</sub>	T <sub>1</sub> T <sub>2</sub> T <sub>3</sub>	1st op-code Address	1st op-code	0	1	0	1	0	1	0
	MC <sub>2</sub>	T <sub>1</sub> T <sub>2</sub> T <sub>3</sub>	1st operand Address	j-2	0	1	0	1	1	1	1
JR C <sub>j</sub> JR NC <sub>j</sub> JR Z <sub>j</sub> JR NZ <sub>j</sub> (If condition is true)	MC <sub>1</sub>	T <sub>1</sub> T <sub>2</sub> T <sub>3</sub>	1st op-code Address	1st op-code	0	1	0	1	0	1	0
	MC <sub>2</sub>	T <sub>1</sub> T <sub>2</sub> T <sub>3</sub>	1st operand Address	j-2	0	1	0	1	1	1	1
	MC <sub>3</sub> ~MC <sub>4</sub>	TiT <sub>i</sub>	*	Z	1	1	1	1	1	1	1
LD g,g'	MC <sub>1</sub>	T <sub>1</sub> T <sub>2</sub> T <sub>3</sub>	1st op-code Address	1st op-code	0	1	0	1	0	1	0
	MC <sub>2</sub>	T <sub>i</sub>	*	Z	1	1	1	1	1	1	1
LD g,m	MC <sub>1</sub>	T <sub>1</sub> T <sub>2</sub> T <sub>3</sub>	1st op-code Address	1st op-code	0	1	0	1	0	1	0
	MC <sub>2</sub>	T <sub>1</sub> T <sub>2</sub> T <sub>3</sub>	1st operand Address	m	0	1	0	1	1	1	1

(to be continued)

Instruction	Machine Cycle	States	ADDRESS	DATA	$\overline{RD}$	$\overline{WR}$	$\overline{ME}$	$\overline{IOE}$	$\overline{LIR}$	HALT	ST
LD g, (HL)	MC <sub>1</sub>	T <sub>1</sub> T <sub>2</sub> T <sub>3</sub>	1st op-code Address	1st op-code	0	1	0	1	0	1	0
	MC <sub>2</sub>	T <sub>1</sub> T <sub>2</sub> T <sub>3</sub>	HL	DATA	0	1	0	1	1	1	1
LD g, (IX+d) LD g, (IY+d)	MC <sub>1</sub>	T <sub>1</sub> T <sub>2</sub> T <sub>3</sub>	1st op-code Address	1st op-code	0	1	0	1	0	1	0
	MC <sub>2</sub>	T <sub>1</sub> T <sub>2</sub> T <sub>3</sub>	2nd op-code Address	2nd op-code	0	1	0	1	0	1	1
	MC <sub>3</sub>	T <sub>1</sub> T <sub>2</sub> T <sub>3</sub>	1st operand Address	d	0	1	0	1	1	1	1
	MC <sub>4</sub> ~MC <sub>5</sub>	TITi	*	Z	1	1	1	1	1	1	1
	MC <sub>6</sub>	T <sub>1</sub> T <sub>2</sub> T <sub>3</sub>	IX+d IY+d	DATA	0	1	0	1	1	1	1
LD (HL),g	MC <sub>1</sub>	T <sub>1</sub> T <sub>2</sub> T <sub>3</sub>	1st op-code Address	1st op-code	0	1	0	1	0	1	0
	MC <sub>2</sub>	Ti	*	Z	1	1	1	1	1	1	1
	MC <sub>3</sub>	T <sub>1</sub> T <sub>2</sub> T <sub>3</sub>	HL	g	1	0	0	1	1	1	1
LD (IX+d),g LD (IY+d),g	MC <sub>1</sub>	T <sub>1</sub> T <sub>2</sub> T <sub>3</sub>	1st op-code Address	1st op-code	0	1	0	1	0	1	0
	MC <sub>2</sub>	T <sub>1</sub> T <sub>2</sub> T <sub>3</sub>	2nd op-code Address	2nd op-code	0	1	0	1	0	1	1
	MC <sub>3</sub>	T <sub>1</sub> T <sub>2</sub> T <sub>3</sub>	1st operand Address	d	0	1	0	1	1	1	1
	MC <sub>4</sub> ~MC <sub>6</sub>	TITITi	*	Z	1	1	1	1	1	1	1
	MC <sub>7</sub>	T <sub>1</sub> T <sub>2</sub> T <sub>3</sub>	IX+d IY+d	g	1	0	0	1	1	1	1
LD (HL),m	MC <sub>1</sub>	T <sub>1</sub> T <sub>2</sub> T <sub>3</sub>	1st op-code Address	1st op-code	0	1	0	1	0	1	0
	MC <sub>2</sub>	T <sub>1</sub> T <sub>2</sub> T <sub>3</sub>	1st operand Address	m	0	1	0	1	1	1	1
	MC <sub>3</sub>	T <sub>1</sub> T <sub>2</sub> T <sub>3</sub>	HL	DATA	1	0	0	1	1	1	1
LD (IX+d),m LD (IY+d),m	MC <sub>1</sub>	T <sub>1</sub> T <sub>2</sub> T <sub>3</sub>	1st op-code Address	1st op-code	0	1	0	1	0	1	0
	MC <sub>2</sub>	T <sub>1</sub> T <sub>2</sub> T <sub>3</sub>	2nd op-code Address	2nd op-code	0	1	0	1	0	1	1
	MC <sub>3</sub>	T <sub>1</sub> T <sub>2</sub> T <sub>3</sub>	1st operand Address	d	0	1	0	1	1	1	1
	MC <sub>4</sub>	T <sub>1</sub> T <sub>2</sub> T <sub>3</sub>	2nd operand Address	m	0	1	0	1	1	1	1
	MC <sub>5</sub>	T <sub>1</sub> T <sub>2</sub> T <sub>3</sub>	IX+d IY+d	DATA	1	0	0	1	1	1	1
LD A, (BC) LD A, (DE)	MC <sub>1</sub>	T <sub>1</sub> T <sub>2</sub> T <sub>3</sub>	1st op-code Address	1st op-code	0	1	0	1	0	1	0

(to be continued)

# HD64180R/Z

Instruction	Machine Cycle	States	ADDRESS	DATA	RD	WR	ME	IOE	LIR	HALT	ST
LD A, (BC) LD A, (DE)	MC <sub>2</sub>	T <sub>1</sub> T <sub>2</sub> T <sub>3</sub>	BC DE	DATA	0	1	0	1	1	1	1
LD A, (mn)	MC <sub>1</sub>	T <sub>1</sub> T <sub>2</sub> T <sub>3</sub>	1st op-code Address	1st op-code	0	1	0	1	0	1	0
	MC <sub>2</sub>	T <sub>1</sub> T <sub>2</sub> T <sub>3</sub>	1st operand Address	n	0	1	0	1	1	1	1
	MC <sub>3</sub>	T <sub>1</sub> T <sub>2</sub> T <sub>3</sub>	2nd operand Address	m	0	1	0	1	1	1	1
	MC <sub>4</sub>	T <sub>1</sub> T <sub>2</sub> T <sub>3</sub>	mn	DATA	0	1	0	1	1	1	1
LD (BC), A LD (DE), A	MC <sub>1</sub>	T <sub>1</sub> T <sub>2</sub> T <sub>3</sub>	1st op-code Address	1st op-code	0	1	0	1	0	1	0
	MC <sub>2</sub>	T <sub>i</sub>	.	Z	1	1	1	1	1	1	1
	MC <sub>3</sub>	T <sub>1</sub> T <sub>2</sub> T <sub>3</sub>	BC DE	A	1	0	0	1	1	1	1
LD (mn), A	MC <sub>1</sub>	T <sub>1</sub> T <sub>2</sub> T <sub>3</sub>	1st op-code Address	1st op-code	0	1	0	1	0	1	0
	MC <sub>2</sub>	T <sub>1</sub> T <sub>2</sub> T <sub>3</sub>	1st operand Address	n	0	1	0	1	1	1	1
	MC <sub>3</sub>	T <sub>1</sub> T <sub>2</sub> T <sub>3</sub>	2nd operand Address	m	0	1	0	1	1	1	1
	MC <sub>4</sub>	T <sub>i</sub>	.	Z	1	1	1	1	1	1	1
	MC <sub>5</sub>	T <sub>1</sub> T <sub>2</sub> T <sub>3</sub>	mn	A	1	0	0	1	1	1	1
LD A, I LD A, R LD I, A LD R, A	MC <sub>1</sub>	T <sub>1</sub> T <sub>2</sub> T <sub>3</sub>	1st op-code Address	1st op-code	0	1	0	1	0	1	0
	MC <sub>2</sub>	T <sub>1</sub> T <sub>2</sub> T <sub>3</sub>	2nd op-code Address	2nd op-code	0	1	0	1	0	1	1
LD w, mn	MC <sub>1</sub>	T <sub>1</sub> T <sub>2</sub> T <sub>3</sub>	1st op-code Address	1st op-code	0	1	0	1	0	1	0
	MC <sub>2</sub>	T <sub>1</sub> T <sub>2</sub> T <sub>3</sub>	1st operand Address	n	0	1	0	1	1	1	1
	MC <sub>3</sub>	T <sub>1</sub> T <sub>2</sub> T <sub>3</sub>	2nd operand Address	m	0	1	0	1	1	1	1
LD IX, mn LD IY, mn	MC <sub>1</sub>	T <sub>1</sub> T <sub>2</sub> T <sub>3</sub>	1st op-code Address	1st op-code	0	1	0	1	0	1	0
	MC <sub>2</sub>	T <sub>1</sub> T <sub>2</sub> T <sub>3</sub>	2nd op-code Address	2nd op-code	0	1	0	1	0	1	1
	MC <sub>3</sub>	T <sub>1</sub> T <sub>2</sub> T <sub>3</sub>	1st operand Address	n	0	1	0	1	1	1	1
	MC <sub>4</sub>	T <sub>1</sub> T <sub>2</sub> T <sub>3</sub>	2nd operand Address	m	0	1	0	1	1	1	1
LD HL, (mn)	MC <sub>1</sub>	T <sub>1</sub> T <sub>2</sub> T <sub>3</sub>	1st op-code Address	1st op-code	0	1	0	1	0	1	0
	MC <sub>2</sub>	T <sub>1</sub> T <sub>2</sub> T <sub>3</sub>	1st operand Address	n	0	1	0	1	1	1	1

(to be continued)



Instruction	Machine Cycle	States	ADDRESS	DATA	RD	WR	ME	IOE	UIR	HALT	ST
LD HL, (mn)	MC <sub>3</sub>	T <sub>1</sub> T <sub>2</sub> T <sub>3</sub>	2nd operand Address	m	0	1	0	1	1	1	1
	MC <sub>4</sub>	T <sub>1</sub> T <sub>2</sub> T <sub>3</sub>	mn	DATA	0	1	0	1	1	1	1
	MC <sub>5</sub>	T <sub>1</sub> T <sub>2</sub> T <sub>3</sub>	mn+1	DATA	0	1	0	1	1	1	1
LD ww, (mn)	MC <sub>1</sub>	T <sub>1</sub> T <sub>2</sub> T <sub>3</sub>	1st op-code Address	1st op-code	0	1	0	1	0	1	0
	MC <sub>2</sub>	T <sub>1</sub> T <sub>2</sub> T <sub>3</sub>	2nd op-code Address	2nd op-code	0	1	0	1	0	1	1
	MC <sub>3</sub>	T <sub>1</sub> T <sub>2</sub> T <sub>3</sub>	1st operand Address	n	0	1	0	1	1	1	1
	MC <sub>4</sub>	T <sub>1</sub> T <sub>2</sub> T <sub>3</sub>	2nd operand Address	m	0	1	0	1	1	1	1
	MC <sub>5</sub>	T <sub>1</sub> T <sub>2</sub> T <sub>3</sub>	mn	DATA	0	1	0	1	1	1	1
	MC <sub>6</sub>	T <sub>1</sub> T <sub>2</sub> T <sub>3</sub>	mn+1	DATA	0	1	0	1	1	1	1
LD IX, (mn) LD IY, (mn)	MC <sub>1</sub>	T <sub>1</sub> T <sub>2</sub> T <sub>3</sub>	1st op-code Address	1st op-code	0	1	0	1	0	1	0
	MC <sub>2</sub>	T <sub>1</sub> T <sub>2</sub> T <sub>3</sub>	2nd op-code Address	2nd op-code	0	1	0	1	0	1	1
	MC <sub>3</sub>	T <sub>1</sub> T <sub>2</sub> T <sub>3</sub>	1st operand Address	n	0	1	0	1	1	1	1
	MC <sub>4</sub>	T <sub>1</sub> T <sub>2</sub> T <sub>3</sub>	2nd operand Address	m	0	1	0	1	1	1	1
	MC <sub>5</sub>	T <sub>1</sub> T <sub>2</sub> T <sub>3</sub>	mn	DATA	0	1	0	1	1	1	1
	MC <sub>6</sub>	T <sub>1</sub> T <sub>2</sub> T <sub>3</sub>	mn+1	DATA	0	1	0	1	1	1	1
LD (mn), HL	MC <sub>1</sub>	T <sub>1</sub> T <sub>2</sub> T <sub>3</sub>	1st op-code Address	1st op-code	0	1	0	1	0	1	0
	MC <sub>2</sub>	T <sub>1</sub> T <sub>2</sub> T <sub>3</sub>	1st operand Address	n	0	1	0	1	1	1	1
	MC <sub>3</sub>	T <sub>1</sub> T <sub>2</sub> T <sub>3</sub>	2nd operand Address	m	0	1	0	1	1	1	1
	MC <sub>4</sub>	T <sub>i</sub>	*	Z	1	1	1	1	1	1	1
	MC <sub>5</sub>	T <sub>1</sub> T <sub>2</sub> T <sub>3</sub>	mn	L	1	0	0	1	1	1	1
	MC <sub>6</sub>	T <sub>1</sub> T <sub>2</sub> T <sub>3</sub>	mn+1	H	1	0	0	1	1	1	1

(to be continued)

Instruction	Machine Cycle	States	ADDRESS	DATA	RD	WR	ME	IOE	LIR	HALT	ST
LD (mn),ww	MC <sub>1</sub>	T <sub>1</sub> T <sub>2</sub> T <sub>3</sub>	1st op-code Address	1st op-code	0	1	0	1	0	1	0
	MC <sub>2</sub>	T <sub>1</sub> T <sub>2</sub> T <sub>3</sub>	2nd op-code Address	2nd op-code	0	1	0	1	0	1	1
	MC <sub>3</sub>	T <sub>1</sub> T <sub>2</sub> T <sub>3</sub>	1st operand Address	n	0	1	0	1	1	1	1
	MC <sub>4</sub>	T <sub>1</sub> T <sub>2</sub> T <sub>3</sub>	2nd operand Address	m	0	1	0	1	1	1	1
	MC <sub>5</sub>	T <sub>i</sub>	*	Z	1	1	1	1	1	1	1
	MC <sub>6</sub>	T <sub>1</sub> T <sub>2</sub> T <sub>3</sub>	mn	wwL	1	0	0	1	1	1	1
	MC <sub>7</sub>	T <sub>1</sub> T <sub>2</sub> T <sub>3</sub>	mn+1	wwH	1	0	0	1	1	1	1
LD (mn),IX LD (mn),IY	MC <sub>1</sub>	T <sub>1</sub> T <sub>2</sub> T <sub>3</sub>	1st op-code Address	1st op-code	0	1	0	1	0	1	0
	MC <sub>2</sub>	T <sub>1</sub> T <sub>2</sub> T <sub>3</sub>	2nd op-code Address	2nd op-code	0	1	0	1	0	1	1
	MC <sub>3</sub>	T <sub>1</sub> T <sub>2</sub> T <sub>3</sub>	1st operand Address	n	0	1	0	1	1	1	1
	MC <sub>4</sub>	T <sub>1</sub> T <sub>2</sub> T <sub>3</sub>	2nd operand Address	m	0	1	0	1	1	1	1
	MC <sub>5</sub>	T <sub>i</sub>	*	Z	1	1	1	1	1	1	1
	MC <sub>6</sub>	T <sub>1</sub> T <sub>2</sub> T <sub>3</sub>	mn	IXL IYL	1	0	0	1	1	1	1
	MC <sub>7</sub>	T <sub>1</sub> T <sub>2</sub> T <sub>3</sub>	mn+1	IXH IYH	1	0	0	1	1	1	1
LD SP, HL	MC <sub>1</sub>	T <sub>1</sub> T <sub>2</sub> T <sub>3</sub>	1st op-code Address	1st op-code	0	1	0	1	0	1	0
	MC <sub>2</sub>	T <sub>i</sub>	*	Z	1	1	1	1	1	1	1
LD SP,IX LD SP,IY	MC <sub>1</sub>	T <sub>1</sub> T <sub>2</sub> T <sub>3</sub>	1st op-code Address	1st op-code	0	1	0	1	0	1	0
	MC <sub>2</sub>	T <sub>1</sub> T <sub>2</sub> T <sub>3</sub>	2nd op-code Address	2nd op-code	0	1	0	1	0	1	1
	MC <sub>3</sub>	T <sub>i</sub>	*	Z	1	1	1	1	1	1	1
LDI LDD	MC <sub>1</sub>	T <sub>1</sub> T <sub>2</sub> T <sub>3</sub>	1st op-code Address	1st op-code	0	1	0	1	0	1	0
	MC <sub>2</sub>	T <sub>1</sub> T <sub>2</sub> T <sub>3</sub>	2nd op-code Address	2nd op-code	0	1	0	1	0	1	1
	MC <sub>3</sub>	T <sub>1</sub> T <sub>2</sub> T <sub>3</sub>	HL	DATA	0	1	0	1	1	1	1
	MC <sub>4</sub>	T <sub>1</sub> T <sub>2</sub> T <sub>3</sub>	DE	DATA	1	0	0	1	1	1	1

(to be continued)

Instruction	Machine Cycle	States	ADDRESS	DATA	RD	WR	ME	OE	IR	HALT	ST
LDR LDDR (if BC <sub>R</sub> ≠0)	MC <sub>1</sub>	T <sub>1</sub> T <sub>2</sub> T <sub>3</sub>	1st op-code Address	1st op-code	0	1	0	1	0	1	0
	MC <sub>2</sub>	T <sub>1</sub> T <sub>2</sub> T <sub>3</sub>	2nd op-code Address	2nd op-code	0	1	0	1	0	1	1
	MC <sub>3</sub>	T <sub>1</sub> T <sub>2</sub> T <sub>3</sub>	HL	DATA	0	1	0	1	1	1	1
	MC <sub>4</sub>	T <sub>1</sub> T <sub>2</sub> T <sub>3</sub>	DE	DATA	1	0	0	1	1	1	1
	MC <sub>5</sub> ~MC <sub>6</sub>	TITI	.	Z	1	1	1	1	1	1	1
LDR LDDR (if BC <sub>R</sub> =0)	MC <sub>1</sub>	T <sub>1</sub> T <sub>2</sub> T <sub>3</sub>	1st op-code Address	1st op-code	0	1	0	1	0	1	0
	MC <sub>2</sub>	T <sub>1</sub> T <sub>2</sub> T <sub>3</sub>	2nd op-code Address	2nd op-code	0	1	0	1	0	1	1
	MC <sub>3</sub>	T <sub>1</sub> T <sub>2</sub> T <sub>3</sub>	HL	DATA	0	1	0	1	1	1	1
	MC <sub>4</sub>	T <sub>1</sub> T <sub>2</sub> T <sub>3</sub>	DE	DATA	1	0	0	1	1	1	1
MLT ww	MC <sub>1</sub>	T <sub>1</sub> T <sub>2</sub> T <sub>3</sub>	1st op-code Address	1st op-code	0	1	0	1	0	1	0
	MC <sub>2</sub>	T <sub>1</sub> T <sub>2</sub> T <sub>3</sub>	2nd op-code Address	2nd op-code	0	1	0	1	0	1	1
	MC <sub>3</sub> ~MC <sub>13</sub>	TITITITI TITITITI TITITI	.	Z	1	1	1	1	1	1	1
NEG	MC <sub>1</sub>	T <sub>1</sub> T <sub>2</sub> T <sub>3</sub>	1st op-code Address	1st op-code	0	1	0	1	0	1	0
	MC <sub>2</sub>	T <sub>1</sub> T <sub>2</sub> T <sub>3</sub>	2nd op-code Address	2nd op-code	0	1	0	1	0	1	1
NOP	MC <sub>1</sub>	T <sub>1</sub> T <sub>2</sub> T <sub>3</sub>	1st op-code Address	1st op-code	0	1	0	1	0	1	0
OUT (m),A	MC <sub>1</sub>	T <sub>1</sub> T <sub>2</sub> T <sub>3</sub>	1st op-code Address	1st op-code	0	1	0	1	0	1	0
	MC <sub>2</sub>	T <sub>1</sub> T <sub>2</sub> T <sub>3</sub>	1st operand Address	m	0	1	0	1	1	1	1
	MC <sub>3</sub>	Ti	.	Z	1	1	1	1	1	1	1
	MC <sub>4</sub>	T <sub>1</sub> T <sub>2</sub> T <sub>3</sub>	m to A <sub>0</sub> ~A <sub>7</sub> A to A <sub>8</sub> ~A <sub>15</sub>	A	1	0	1	0	1	1	1

(to be continued)

Instruction	Machine Cycle	States	ADDRESS	DATA	$\overline{RD}$	WR	ME	$\overline{IOE}$	$\overline{LIR}$	HALT	ST
OUT (C).g	MC <sub>1</sub>	T <sub>1</sub> T <sub>2</sub> T <sub>3</sub>	1st op-code Address	1st op-code	0	1	0	1	0	1	0
	MC <sub>2</sub>	T <sub>1</sub> T <sub>2</sub> T <sub>3</sub>	2nd op-code Address	2nd op-code	0	1	0	1	0	1	1
	MC <sub>3</sub>	T <sub>i</sub>	*	Z	1	1	1	1	1	1	1
	MC <sub>4</sub>	T <sub>1</sub> T <sub>2</sub> T <sub>3</sub>	BC	g	1	0	1	0	1	1	1
OUTO (m).g	MC <sub>1</sub>	T <sub>1</sub> T <sub>2</sub> T <sub>3</sub>	1st op-code Address	1st op-code	0	1	0	1	0	1	0
	MC <sub>2</sub>	T <sub>1</sub> T <sub>2</sub> T <sub>3</sub>	2nd op-code Address	2nd op-code	0	1	0	1	0	1	1
	MC <sub>3</sub>	T <sub>1</sub> T <sub>2</sub> T <sub>3</sub>	1st operand Address	m	0	1	0	1	1	1	1
	MC <sub>4</sub>	T <sub>i</sub>	*	Z	1	1	1	1	1	1	1
	MC <sub>5</sub>	T <sub>1</sub> T <sub>2</sub> T <sub>3</sub>	m to A <sub>0</sub> ~A <sub>7</sub> OOH to A <sub>8</sub> ~A <sub>15</sub>	g	1	0	1	0	1	1	1
OTIM OTDM	MC <sub>1</sub>	T <sub>1</sub> T <sub>2</sub> T <sub>3</sub>	1st op-code Address	1st op-code	0	1	0	1	0	1	0
	MC <sub>2</sub>	T <sub>1</sub> T <sub>2</sub> T <sub>3</sub>	2nd op-code Address	2nd op-code	0	1	0	1	0	1	1
	MC <sub>3</sub>	T <sub>i</sub>	*	Z	1	1	1	1	1	1	1
	MC <sub>4</sub>	T <sub>1</sub> T <sub>2</sub> T <sub>3</sub>	HL	DATA	0	1	0	1	1	1	1
	MC <sub>5</sub>	T <sub>1</sub> T <sub>2</sub> T <sub>3</sub>	C to A <sub>0</sub> ~A <sub>7</sub> OOH to A <sub>8</sub> ~A <sub>15</sub>	DATA	1	0	1	0	1	1	1
	MC <sub>6</sub>	T <sub>i</sub>	*	Z	1	1	1	1	1	1	1
OTIMR OTDMR (If Br≠0)	MC <sub>1</sub>	T <sub>1</sub> T <sub>2</sub> T <sub>3</sub>	1st op-code Address	1st op-code	0	1	0	1	0	1	0
	MC <sub>2</sub>	T <sub>1</sub> T <sub>2</sub> T <sub>3</sub>	2nd op-code Address	2nd op-code	0	1	0	1	0	1	1
	MC <sub>3</sub>	T <sub>i</sub>	*	Z	1	1	1	1	1	1	1
	MC <sub>4</sub>	T <sub>1</sub> T <sub>2</sub> T <sub>3</sub>	HL	DATA	0	1	0	1	1	1	1
	MC <sub>5</sub>	T <sub>1</sub> T <sub>2</sub> T <sub>3</sub>	C to A <sub>0</sub> ~A <sub>7</sub> OOH to A <sub>8</sub> ~A <sub>15</sub>	DATA	1	0	1	0	1	1	1
	MC <sub>6</sub> ~MC <sub>1</sub>	T <sub>i</sub> T <sub>i</sub> T <sub>i</sub> T <sub>i</sub>	*	Z	1	1	1	1	1	1	1

(to be continued)

Instruction	Machine Cycle	States	ADDRESS	DATA	RD	WR	ME	IOE	IOR	HALT	ST
OTMR OTDMR (If Br=0)	MC <sub>1</sub>	T <sub>1</sub> T <sub>2</sub> T <sub>3</sub>	1st op-code Address	1st op-code	0	1	0	1	0	1	0
	MC <sub>2</sub>	T <sub>1</sub> T <sub>2</sub> T <sub>3</sub>	2nd op-code Address	2nd op-code	0	1	0	1	0	1	1
	MC <sub>3</sub>	T <sub>i</sub>	*	Z	1	1	1	1	1	1	1
	MC <sub>4</sub>	T <sub>1</sub> T <sub>2</sub> T <sub>3</sub>	HL	DATA	0	1	0	1	1	1	1
	MC <sub>5</sub>	T <sub>1</sub> T <sub>2</sub> T <sub>3</sub>	C to A <sub>0</sub> ~A <sub>7</sub> OOH to A <sub>8</sub> ~A <sub>15</sub>	DATA	1	0	1	0	1	1	1
	MC <sub>6</sub>	T <sub>i</sub>	*	Z	1	1	1	1	1	1	1
OUTI OUTD	MC <sub>1</sub>	T <sub>1</sub> T <sub>2</sub> T <sub>3</sub>	1st op-code Address	1st op-code	0	1	0	1	0	1	0
	MC <sub>2</sub>	T <sub>1</sub> T <sub>2</sub> T <sub>3</sub>	2nd op-code Address	2nd op-code	0	1	0	1	0	1	1
	MC <sub>3</sub>	T <sub>1</sub> T <sub>2</sub> T <sub>3</sub>	HL	DATA	0	1	0	1	1	1	1
	MC <sub>4</sub>	T <sub>1</sub> T <sub>2</sub> T <sub>3</sub>	BC	DATA	1	0	1	0	1	1	1
OTIR OTDR (If Br≠0)	MC <sub>1</sub>	T <sub>1</sub> T <sub>2</sub> T <sub>3</sub>	1st op-code Address	1st op-code	0	1	0	1	0	1	0
	MC <sub>2</sub>	T <sub>1</sub> T <sub>2</sub> T <sub>3</sub>	2nd op-code Address	2nd op-code	0	1	0	1	0	1	1
	MC <sub>3</sub>	T <sub>1</sub> T <sub>2</sub> T <sub>3</sub>	HL	DATA	0	1	0	1	1	1	1
	MC <sub>4</sub>	T <sub>1</sub> T <sub>2</sub> T <sub>3</sub>	BC	DATA	1	0	1	0	1	1	1
	MC <sub>5</sub> ~MC <sub>6</sub>	T <sub>i</sub> T <sub>i</sub>	*	Z	1	1	1	1	1	1	1
OTIR OTDR (If Br=0)	MC <sub>1</sub>	T <sub>1</sub> T <sub>2</sub> T <sub>3</sub>	1st op-code Address	1st op-code	0	1	0	1	0	1	0
	MC <sub>2</sub>	T <sub>1</sub> T <sub>2</sub> T <sub>3</sub>	2nd op-code Address	2nd op-code	0	1	0	1	0	1	1
	MC <sub>3</sub>	T <sub>1</sub> T <sub>2</sub> T <sub>3</sub>	HL	DATA	0	1	0	1	1	1	1
	MC <sub>4</sub>	T <sub>1</sub> T <sub>2</sub> T <sub>3</sub>	BC	DATA	1	0	1	0	1	1	1
POP zz	MC <sub>1</sub>	T <sub>1</sub> T <sub>2</sub> T <sub>3</sub>	1st op-code Address	1st op-code	0	1	0	1	0	1	0
	MC <sub>2</sub>	T <sub>1</sub> T <sub>2</sub> T <sub>3</sub>	SP	DATA	0	1	0	1	1	1	1
	MC <sub>3</sub>	T <sub>1</sub> T <sub>2</sub> T <sub>3</sub>	SP+1	DATA	0	1	0	1	1	1	1
POP IX POP IY	MC <sub>1</sub>	T <sub>1</sub> T <sub>2</sub> T <sub>3</sub>	1st op-code Address	1st op-code	0	1	0	1	0	1	0

(to be continued)

# HD64180R/Z

Instruction	Machine Cycle	States	ADDRESS	DATA	RD	WR	ME	OE	LIR	HALT	ST
POP IX POP IY	MC <sub>2</sub>	T <sub>1</sub> T <sub>2</sub> T <sub>3</sub>	2nd op-code Address	2nd op-code	0	1	0	1	0	1	1
	MC <sub>3</sub>	T <sub>1</sub> T <sub>2</sub> T <sub>3</sub>	SP	DATA	0	1	0	1	1	1	1
	MC <sub>4</sub>	T <sub>1</sub> T <sub>2</sub> T <sub>3</sub>	SP+1	DATA	0	1	0	1	1	1	1
PUSH zz	MC <sub>1</sub>	T <sub>1</sub> T <sub>2</sub> T <sub>3</sub>	1st op-code Address	1st op-code	0	1	0	1	0	1	0
	MC <sub>2</sub> ~MC <sub>3</sub>	T <sub>i</sub> T <sub>i</sub>	*	Z	1	1	1	1	1	1	1
	MC <sub>4</sub>	T <sub>1</sub> T <sub>2</sub> T <sub>3</sub>	SP-1	zzH	1	0	0	1	1	1	1
	MC <sub>5</sub>	T <sub>1</sub> T <sub>2</sub> T <sub>3</sub>	SP-2	zzL	1	0	0	1	1	1	1
PUSH IX PUSH IY	MC <sub>1</sub>	T <sub>1</sub> T <sub>2</sub> T <sub>3</sub>	1st op-code Address	1st op-code	0	1	0	1	0	1	0
	MC <sub>2</sub>	T <sub>1</sub> T <sub>2</sub> T <sub>3</sub>	2nd op-code Address	2nd op-code	0	1	0	1	0	1	1
	MC <sub>3</sub> ~MC <sub>4</sub>	T <sub>i</sub> T <sub>i</sub>	*	Z	1	1	1	1	1	1	1
	MC <sub>5</sub>	T <sub>1</sub> T <sub>2</sub> T <sub>3</sub>	SP-1	IXH IYH	1	0	0	1	1	1	1
	MC <sub>6</sub>	T <sub>1</sub> T <sub>2</sub> T <sub>3</sub>	SP-2	IXL IYL	1	0	0	1	1	1	1
RET	MC <sub>1</sub>	T <sub>1</sub> T <sub>2</sub> T <sub>3</sub>	1st op-code Address	1st op-code	0	1	0	1	0	1	0
	MC <sub>2</sub>	T <sub>1</sub> T <sub>2</sub> T <sub>3</sub>	SP	DATA	0	1	0	1	1	1	1
	MC <sub>3</sub>	T <sub>1</sub> T <sub>2</sub> T <sub>3</sub>	SP+1	DATA	0	1	0	1	1	1	1
RET f (If condition is false)	MC <sub>1</sub>	T <sub>1</sub> T <sub>2</sub> T <sub>3</sub>	1st op-code Address	1st op-code	0	1	0	1	0	1	0
	MC <sub>2</sub> ~MC <sub>3</sub>	T <sub>i</sub> T <sub>i</sub>	*	Z	1	1	1	1	1	1	1
RET f (If condition is true)	MC <sub>1</sub>	T <sub>1</sub> T <sub>2</sub> T <sub>3</sub>	1st op-code Address	1st op-code	0	1	0	1	0	1	0
	MC <sub>2</sub>	T <sub>i</sub>	*	Z	1	1	1	1	1	1	1
	MC <sub>3</sub>	T <sub>1</sub> T <sub>2</sub> T <sub>3</sub>	SP	DATA	0	1	0	1	1	1	1
	MC <sub>4</sub>	T <sub>1</sub> T <sub>2</sub> T <sub>3</sub>	SP+1	DATA	0	1	0	1	1	1	1
RETI RETN	MC <sub>1</sub>	T <sub>1</sub> T <sub>2</sub> T <sub>3</sub>	1st op-code Address	1st op-code	0	1	0	1	0	1	0
	MC <sub>2</sub>	T <sub>1</sub> T <sub>2</sub> T <sub>3</sub>	2nd op-code Address	2nd op-code	0	1	0	1	0	1	1

(to be continued)

Instruction	Machine Cycle	States	ADDRESS	DATA	RD	WR	ME	OE	IR	HALT	ST
RETI RETN	MC <sub>3</sub>	T <sub>1</sub> T <sub>2</sub> T <sub>3</sub>	SP	DATA	0	1	0	1	1	1	1
	MC <sub>4</sub>	T <sub>1</sub> T <sub>2</sub> T <sub>3</sub>	SP + 1	DATA	0	1	0	1	1	1	1
RLCA RLA RRCA RRA	MC <sub>1</sub>	T <sub>1</sub> T <sub>2</sub> T <sub>3</sub>	1st op-code Address	1st op-code	0	1	0	1	0	1	0
RLC g RL g RRC g RR g SLA g SRA g SRL g	MC <sub>1</sub>	T <sub>1</sub> T <sub>2</sub> T <sub>3</sub>	1st op-code Address	1st op-code	0	1	0	1	0	1	0
	MC <sub>2</sub>	T <sub>1</sub> T <sub>2</sub> T <sub>3</sub>	2nd op-code Address	2nd op-code	0	1	0	1	0	1	1
	MC <sub>3</sub>	T <sub>i</sub>	.	Z	1	1	1	1	1	1	1
RLC (HL) RL (HL) RRC (HL) RR (HL) SLA (HL) SRA (HL) SRL (HL)	MC <sub>1</sub>	T <sub>1</sub> T <sub>2</sub> T <sub>3</sub>	1st op-code Address	1st op-code	0	1	0	1	0	1	0
	MC <sub>2</sub>	T <sub>1</sub> T <sub>2</sub> T <sub>3</sub>	2nd op-code Address	2nd op-code	0	1	0	1	0	1	1
	MC <sub>3</sub>	T <sub>1</sub> T <sub>2</sub> T <sub>3</sub>	HL	DATA	0	1	0	1	1	1	1
	MC <sub>4</sub>	T <sub>i</sub>	.	Z	1	1	1	1	1	1	1
	MC <sub>5</sub>	T <sub>1</sub> T <sub>2</sub> T <sub>3</sub>	HL	DATA	1	0	0	1	1	1	1
RLC (IX+d) RLC (IY+d) RL (IX+d) RL (IY+d) RRC (IX+d) RRC (IY+d) RR (IX+d) RR (IY+d) SLA (IX+d) SLA (IY+d) SRA (IX+d) SRA (IY+d) SRL (IX+d) SRL (IY+d)	MC <sub>1</sub>	T <sub>1</sub> T <sub>2</sub> T <sub>3</sub>	1st op-code Address	1st op-code	0	1	0	1	0	1	0
	MC <sub>2</sub>	T <sub>1</sub> T <sub>2</sub> T <sub>3</sub>	2nd op-code Address	2nd op-code	0	1	0	1	0	1	1
	MC <sub>3</sub>	T <sub>1</sub> T <sub>2</sub> T <sub>3</sub>	1st operand Address	d	0	1	0	1	1	1	1
	MC <sub>4</sub>	T <sub>1</sub> T <sub>2</sub> T <sub>3</sub>	3rd op-code Address	3rd op-code	0	1	0	1	0	1	1
	MC <sub>5</sub>	T <sub>1</sub> T <sub>2</sub> T <sub>3</sub>	IX+d IY+d	DATA	0	1	0	1	1	1	1
	MC <sub>6</sub>	T <sub>i</sub>	.	Z	1	1	1	1	1	1	1
	MC <sub>7</sub>	T <sub>1</sub> T <sub>2</sub> T <sub>3</sub>	IX+d IY+d	DATA	1	0	0	1	1	1	1
	MC <sub>8</sub>	T <sub>1</sub> T <sub>2</sub> T <sub>3</sub>	HL	DATA	1	0	0	1	1	1	1
RLD RRD	MC <sub>1</sub>	T <sub>1</sub> T <sub>2</sub> T <sub>3</sub>	1st op-code Address	1st op-code	0	1	0	1	0	1	0
	MC <sub>2</sub>	T <sub>1</sub> T <sub>2</sub> T <sub>3</sub>	2nd op-code Address	2nd op-code	0	1	0	1	0	1	1
	MC <sub>3</sub>	T <sub>1</sub> T <sub>2</sub> T <sub>3</sub>	HL	DATA	0	1	0	1	1	1	1

(to be continued)

# HD64180R/Z

Instruction	Machine Cycle	States	ADDRESS	DATA	R $\bar{D}$	WR	ME	IOE	UR	RALT	ST
RLD RRD	MC <sub>4</sub> ~MC <sub>7</sub>	T <sub>1</sub> T <sub>1</sub> T <sub>1</sub>	*	Z	1	1	1	1	1	1	1
	MC <sub>8</sub>	T <sub>1</sub> T <sub>2</sub> T <sub>3</sub>	HL	DATA	1	0	0	1	1	1	1
RST v	MC <sub>1</sub>	T <sub>1</sub> T <sub>2</sub> T <sub>3</sub>	1st op-code Address	1st op-code	0	1	0	1	0	1	0
	MC <sub>2</sub> ~MC <sub>3</sub>	T <sub>1</sub> T <sub>1</sub>	*	Z	1	1	1	1	1	1	1
	MC <sub>4</sub>	T <sub>1</sub> T <sub>2</sub> T <sub>3</sub>	SP-1	PCH	1	0	0	1	1	1	1
	MC <sub>5</sub>	T <sub>1</sub> T <sub>2</sub> T <sub>3</sub>	SP-2	PCL	1	0	0	1	1	1	1
SCF	MC <sub>1</sub>	T <sub>1</sub> T <sub>2</sub> T <sub>3</sub>	1st op-code Address	1st op-code	0	1	0	1	0	1	0
SET b,g RES b,g	MC <sub>1</sub>	T <sub>1</sub> T <sub>2</sub> T <sub>3</sub>	1st op-code Address	1st op-code	0	1	0	1	0	1	0
	MC <sub>2</sub>	T <sub>1</sub> T <sub>2</sub> T <sub>3</sub>	2nd op-code Address	2nd op-code	0	1	0	1	0	1	1
	MC <sub>3</sub>	T <sub>i</sub>	*	Z	1	1	1	1	1	1	1
	MC <sub>4</sub>	T <sub>i</sub>	*	Z	1	1	1	1	1	1	1
SET b, (HL) RES b, (HL)	MC <sub>1</sub>	T <sub>1</sub> T <sub>2</sub> T <sub>3</sub>	1st op-code Address	1st op-code	0	1	0	1	0	1	0
	MC <sub>2</sub>	T <sub>1</sub> T <sub>2</sub> T <sub>3</sub>	2nd op-code Address	2nd op-code	0	1	0	1	0	1	1
	MC <sub>3</sub>	T <sub>1</sub> T <sub>2</sub> T <sub>3</sub>	HL	DATA	0	1	0	1	1	1	1
	MC <sub>4</sub>	T <sub>i</sub>	*	Z	1	1	1	1	1	1	1
	MC <sub>5</sub>	T <sub>1</sub> T <sub>2</sub> T <sub>3</sub>	HL	DATA	1	0	0	1	1	1	1
SET b, (IX+d) SET b, (IY+d) RES b, (IX+d) RES b, (IY+d)	MC <sub>1</sub>	T <sub>1</sub> T <sub>2</sub> T <sub>3</sub>	1st op-code Address	1st op-code	0	1	0	1	0	1	0
	MC <sub>2</sub>	T <sub>1</sub> T <sub>2</sub> T <sub>3</sub>	2nd op-code Address	2nd op-code	0	1	0	1	0	1	1
	MC <sub>3</sub>	T <sub>1</sub> T <sub>2</sub> T <sub>3</sub>	1st operand Address	d	0	1	0	1	1	1	1
	MC <sub>4</sub>	T <sub>1</sub> T <sub>2</sub> T <sub>3</sub>	3rd op-code Address	3rd op-code	0	1	0	1	0	1	1
	MC <sub>5</sub>	T <sub>1</sub> T <sub>2</sub> T <sub>3</sub>	IX+d IY+d	DATA	0	1	0	1	1	1	1
	MC <sub>6</sub>	T <sub>i</sub>	*	Z	1	1	1	1	1	1	1
	MC <sub>7</sub>	T <sub>1</sub> T <sub>2</sub> T <sub>3</sub>	IX+d IY+d	DATA	1	0	0	1	1	1	1

(to be continued)



Instruction	Machine Cycle	States	ADDRESS	DATA	RD	WR	ME	IOE	LIF	HALT	ST
SLP	MC <sub>1</sub>	T <sub>1</sub> T <sub>2</sub> T <sub>3</sub>	1st op-code Address	1st op-code	0	1	0	1	0	1	0
	MC <sub>2</sub>	T <sub>1</sub> T <sub>2</sub> T <sub>3</sub>	2nd op-code Address	2nd op-code	0	1	0	1	0	1	1
	—	—	7FFFFH	Z	1	1	1	1	1	0	1
TSTIO m	MC <sub>1</sub>	T <sub>1</sub> T <sub>2</sub> T <sub>3</sub>	1st op-code Address	1st op-code	0	1	0	1	0	1	0
	MC <sub>2</sub>	T <sub>1</sub> T <sub>2</sub> T <sub>3</sub>	2nd op-code Address	2nd op-code	0	1	0	1	0	1	1
	MC <sub>3</sub>	T <sub>1</sub> T <sub>2</sub> T <sub>3</sub>	1st operand Address	m	0	1	0	1	1	1	1
	MC <sub>4</sub>	T <sub>1</sub> T <sub>2</sub> T <sub>3</sub>	C to A <sub>0</sub> ~A <sub>7</sub> OOH to A <sub>n</sub> ~A <sub>15</sub>	DATA	0	1	1	0	1	1	1
TST g	MC <sub>1</sub>	T <sub>1</sub> T <sub>2</sub> T <sub>3</sub>	1st op-code Address	1st op-code	0	1	0	1	0	1	0
	MC <sub>2</sub>	T <sub>1</sub> T <sub>2</sub> T <sub>3</sub>	2nd op-code Address	2nd op-code	0	1	0	1	0	1	1
	MC <sub>3</sub>	T <sub>i</sub>	*	Z	1	1	1	1	1	1	1
TST m	MC <sub>1</sub>	T <sub>1</sub> T <sub>2</sub> T <sub>3</sub>	1st op-code Address	1st op-code	0	1	0	1	0	1	0
	MC <sub>2</sub>	T <sub>1</sub> T <sub>2</sub> T <sub>3</sub>	2nd op-code Address	2nd op-code	0	1	0	1	0	1	1
	MC <sub>3</sub>	T <sub>1</sub> T <sub>2</sub> T <sub>3</sub>	1st operand Address	m	0	1	0	1	1	1	1
TST (HL)	MC <sub>1</sub>	T <sub>1</sub> T <sub>2</sub> T <sub>3</sub>	1st op-code Address	1st op-code	0	1	0	1	0	1	0
	MC <sub>2</sub>	T <sub>1</sub> T <sub>2</sub> T <sub>3</sub>	2nd op-code Address	2nd op-code	0	1	0	1	0	1	1
	MC <sub>3</sub>	T <sub>i</sub>	*	Z	1	1	1	1	1	1	1
	MC <sub>4</sub>	T <sub>1</sub> T <sub>2</sub> T <sub>3</sub>	HL	DATA	0	1	0	1	1	1	1

INTERRUPT

NMI	MC <sub>1</sub>	T <sub>1</sub> T <sub>2</sub> T <sub>3</sub>	Next op-code Address (PC)		0	1	0	1	0	1	0
	MC <sub>2</sub> ~MC <sub>3</sub>	T <sub>i</sub> T <sub>i</sub>	*	Z	1	1	1	1	1	1	1
	MC <sub>4</sub>	T <sub>1</sub> T <sub>2</sub> T <sub>3</sub>	SP-1	PCH	1	0	0	1	1	1	1
	MC <sub>5</sub>	T <sub>1</sub> T <sub>2</sub> T <sub>3</sub>	SP-2	PCL	1	0	0	1	1	1	1
	INT <sub>0</sub> MODE 0 (RST INSERTED)	MC <sub>1</sub>	T <sub>1</sub> T <sub>2</sub> T <sub>w</sub> T <sub>w</sub> T <sub>3</sub>	Next op-code Address (PC)	1st op-code	1	1	1	0	0	1
MC <sub>2</sub> ~MC <sub>3</sub>		T <sub>i</sub> T <sub>i</sub>	*	Z	1	1	1	1	1	1	1

(to be continued)

Instruction	Machine Cycle	States	ADDRESS	DATA	RD	WR	ME	IOE	LR	HALT	ST
<u>INT<sub>0</sub></u> MODE 0 (RST INSERTED)	MC <sub>4</sub>	T <sub>1</sub> T <sub>2</sub> T <sub>3</sub>	SP-1	PCH	1	0	0	1	1	1	1
	MC <sub>5</sub>	T <sub>1</sub> T <sub>2</sub> T <sub>3</sub>	SP-2	PCL	1	0	0	1	1	1	1
<u>INT<sub>0</sub></u> MODE 0 (CALL INSERTED)	MC <sub>1</sub>	T <sub>1</sub> T <sub>2</sub> T <sub>w</sub> T <sub>w</sub> T <sub>3</sub>	Next op-code Address (PC)	1st op-code	1	1	1	0	0	1	0
	MC <sub>2</sub>	T <sub>1</sub> T <sub>2</sub> T <sub>3</sub>	PC	n	0	1	0	1	1	1	1
	MC <sub>3</sub>	T <sub>1</sub> T <sub>2</sub> T <sub>3</sub>	PC+1	m	0	1	0	1	1	1	1
	MC <sub>4</sub>	T <sub>i</sub>	.	Z	1	1	1	1	1	1	1
	MC <sub>5</sub>	T <sub>1</sub> T <sub>2</sub> T <sub>3</sub>	SP-1	PC+2(H)	1	0	0	1	1	1	1
	MC <sub>6</sub>	T <sub>1</sub> T <sub>2</sub> T <sub>3</sub>	SP-2	PC+2(L)	1	0	0	1	1	1	1
<u>INT<sub>0</sub></u> MODE 1	MC <sub>1</sub>	T <sub>1</sub> T <sub>2</sub> T <sub>w</sub> T <sub>w</sub> T <sub>3</sub>	Next op-code Address (PC)		1	1	1	0	0	1	0
	MC <sub>2</sub>	T <sub>1</sub> T <sub>2</sub> T <sub>3</sub>	SP-1	PCH	1	0	0	1	1	1	1
	MC <sub>3</sub>	T <sub>1</sub> T <sub>2</sub> T <sub>3</sub>	SP-2	PCL	1	0	0	1	1	1	1
<u>INT<sub>0</sub></u> MODE 2	MC <sub>1</sub>	T <sub>1</sub> T <sub>2</sub> T <sub>w</sub> T <sub>w</sub> T <sub>3</sub>	Next op-code Address (PC)	Vector	1	1	1	0	0	1	0
	MC <sub>2</sub>	T <sub>i</sub>	.	Z	1	1	1	1	1	1	1
	MC <sub>3</sub>	T <sub>1</sub> T <sub>2</sub> T <sub>3</sub>	SP-1	PCH	1	0	0	1	1	1	1
	MC <sub>4</sub>	T <sub>1</sub> T <sub>2</sub> T <sub>3</sub>	SP-2	PCL	1	0	0	1	1	1	1
	MC <sub>5</sub>	T <sub>1</sub> T <sub>2</sub> T <sub>3</sub>	I, Vector	DATA	0	1	0	1	1	1	1
	MC <sub>6</sub>	T <sub>1</sub> T <sub>2</sub> T <sub>3</sub>	I, Vector+1	DATA	0	1	0	1	1	1	1
<u>INT<sub>1</sub></u> <u>INT<sub>2</sub></u> Internal Interrupts	MC <sub>1</sub>	T <sub>1</sub> T <sub>2</sub> T <sub>w</sub> T <sub>w</sub> T <sub>3</sub>	Next op-code Address (PC)		1	1	1	1	1	1	0
	MC <sub>2</sub>	T <sub>i</sub>	.	Z	1	1	1	1	1	1	1
	MC <sub>3</sub>	T <sub>1</sub> T <sub>2</sub> T <sub>3</sub>	SP-1	PCH	1	0	0	1	1	1	1
	MC <sub>4</sub>	T <sub>1</sub> T <sub>2</sub> T <sub>3</sub>	SP-2	PCL	1	0	0	1	1	1	1
	MC <sub>5</sub>	T <sub>1</sub> T <sub>2</sub> T <sub>3</sub>	I, Vector	DATA	0	1	0	1	1	1	1
	MC <sub>6</sub>	T <sub>1</sub> T <sub>2</sub> T <sub>3</sub>	I, Vector+1	DATA	0	1	0	1	1	1	1

23 REQUEST ACCEPTANCES IN EACH OPERATING MODE

Request	Current Status	Normal Operation (CPU mode) (SLEEP mode)	WAIT State	Refresh Cycle	Interrupt Acknowledge Cycle	DMA Cycle	BUS RELEASE mode	SLEEP mode	SYSTEM STOP mode
WAIT		Acceptable	Acceptable	Not acceptable	Acceptable	Acceptable	Not acceptable	Not acceptable	Not acceptable
Refresh Request (Request of Refresh by the on-chip Refresh Controller)		Refresh cycle begins at the end of MC.	Not acceptable	Not acceptable	Refresh cycle begins at the end of MC.	Refresh cycle begins at the end of MC.	Not acceptable	Not acceptable	Not acceptable
DREQ <sub>0</sub> DREQ <sub>1</sub>		DMA cycle begins at the end of MC.	DMA cycle begins at the end of MC.	Acceptable • Refresh cycle precedes. DMA cycle begins at the end of one MC.	Acceptable DMA cycle begins at the end of MC.	Acceptable Refer to "2.9 DMA Controller" for details.	Acceptable • After BUS RELEASE cycle, DMA cycle begins at the end of one MC.	Not acceptable	Not acceptable
BUSREQ		Bus is released at the end of MC.	Not acceptable	Not acceptable	Bus is released at the end of MC.	Bus is released at the end of MC.	Continue BUS RELEASE mode.	Acceptable	Acceptable
Interrupt INT <sub>0</sub> , INT <sub>1</sub> , INT <sub>2</sub>		Accepted after executing the current instruction.	Accepted after executing the current instruction	Not acceptable	Not acceptable	Not acceptable	Not acceptable	Acceptable Return from SLEEP mode to normal operation.	Acceptable Return from SYSTEM STOP mode to normal operation.
	Internal I/O	↑	↑	↑	↑	↑	↑	↑	Not acceptable
	NMI	↑	↑	↑	Not acceptable Interrupt acknowledge cycle precedes. NMI is accepted after executing the next instruction.	Acceptable DMA cycle stops.	↑	↑	Acceptable Return from SYSTEM STOP mode to normal operation.

NOTE) \* : not acceptable when DMA Request is in level sense.

↑ : same as the above

MC : Machine Cycle

# HD64180R/Z

## 24 REQUEST PRIORITY

The HD64180 has the following three types of requests.

### Type 1.

To be accepted in specified state. . . . . WAIT

### Type 2.

To be accepted in each machine cycle. . . . . Refresh Req.  
DMA Req.  
Bus Req.

### Type 3.

To be accepted in each instruction. . . . . Interrupt Req.

Type 1, Type 2, and Type 3 requests priority is shown as follows.  
highest priority Type 1 > Type 2 > Type 3 lowest priority  
Each request priority in Type 2 is shown as follows.  
highest priority Bus Req. > Refresh Req. > DMA Req. lowest priority

(NOTE) If Bus Req. and Refresh Req. occurs simultaneously, Bus Req. is accepted but Refresh Req. is cleared.  
Refer to "2.7 Interrupts" for each request priority in Type 3.

## 25 OPERATION MODE TRANSITION

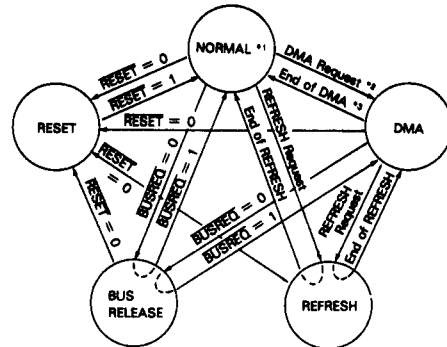
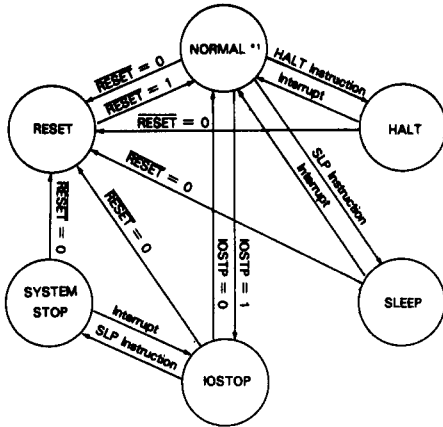

- NOTE \*1 NORMAL: CPU executes instructions normally in NORMAL mode.  
 \*2 DMA request: DMA is requested in the following cases.  
 (1) DREQ<sub>0</sub>, DREQ<sub>1</sub> = 0 (memory ↔ (memory mapped) I/O DMA transfer)  
 (2) DEQ = 1 (memory ↔ memory DMA transfer)  
 \*3 DMA end: DMA ends in the following cases.  
 (1) DREQ<sub>0</sub>, DREQ<sub>1</sub> = 1 (memory ↔ (memory mapped) I/O DMA transfer)  
 (2) BCR<sub>0</sub>, BCR<sub>1</sub> = 0000H (all DMA transfers)  
 (3) NMI = 0 (all DMA transfers)

### Other operation mode transitions

The following operation mode transitions are also possible.

- HALT ↔ { DMA, REFRESH, BUS RELEASE }  
 IOSTOP ↔ { DMA, REFRESH, BUS RELEASE }
- SLEEP ↔ BUS RELEASE  
 SYSTEM STOP ↔ BUS RELEASE

**26 STATUS SIGNALS**

The following table shows pin outputs in each operating mode.

Mode		$\overline{\text{LIR}}$	ME	$\overline{\text{IOE}}$	$\overline{\text{RD}}$	$\overline{\text{WR}}$	$\overline{\text{REF}}$	$\overline{\text{HALT}}$	$\overline{\text{BUSACK}}$	ST	Address BUS	Data BUS
CPU operation	Op-code Fetch (1st op-code)	0	0	1	0	1	1	1	1	0	A	IN
	Op-code Fetch (except 1st op-code)	0	0	1	0	1	1	1	1	1	A	IN
	Memory Read	1	0	1	0	1	1	1	1	1	A	IN
	Memory Write	1	0	1	1	0	1	1	1	1	A	OUT
	I/O Read	1	1	0	0	1	1	1	1	1	A	IN
	I/O Write	1	1	0	1	0	1	1	1	1	A	OUT
Internal Operation		1	1	1	1	1	1	1	1	1	A	IN
Refresh		1	0	1	1	1	0	1	1	*	A	IN
Interrupt Acknowledge Cycle (1st machine cycle)	$\overline{\text{NMI}}$	0	0	1	0	1	1	1	1	0	A	IN
	$\overline{\text{INT}}_0$	0	1	0	1	1	1	1	1	0	A	IN
	$\overline{\text{INT}}_1, \overline{\text{INT}}_2$ & Internal Interrupts	1	1	1	1	1	1	1	1	0	A	IN
BUS RELEASE		1	Z	Z	Z	Z	1	1	0	*	Z	IN
HALT		0	0	1	0	1	1	0	1	0	A	IN
SLEEP		1	1	1	1	1	1	0	1	1	1	IN
Internal DMA	Memory Read	1	0	1	0	1	1	1	1	0	A	IN
	Memory Write	1	0	1	1	0	1	1	1	0	A	OUT
	I/O Read	1	1	0	0	1	1	1	1	0	A	IN
	I/O Write	1	1	0	1	0	1	1	1	0	A	OUT
RESET		1	1	1	1	1	1	1	1	1	Z	IN

NOTE) 1 : HIGH  
 0 : LOW  
 A : Programmable  
 Z : High Impedance  
 IN : Input  
 OUT : Output  
 \* : Invalid

27 PIN STATUS DURING RESET AND LOW POWER OPERATION MODES

Pin No.	Symbol	Pin function	Pin status in each operation mode			
			RESET	SLEEP	IOSTOP	SYSTEM STOP
4	WAIT	—	IN (N)	IN (N)	IN (A)	IN (N)
6	BUSACK	—	1	OUT	OUT	OUT
6	BUSREQ	—	IN (N)	IN (A)	IN (A)	IN (A)
7	RESET	—	0	IN (A)	IN (A)	IN (A)
8	NMI	—	IN (N)	IN (A)	IN (A)	IN (A)
9	INT <sub>0</sub>	—	IN (N)	IN (A)	IN (A)	IN (A)
10	INT <sub>1</sub>	—	IN (N)	IN (A)	IN (A)	IN (A)
11	INT <sub>2</sub>	—	IN (N)	IN (A)	IN (A)	IN (A)
12	ST	—	1	1	OUT	1
13~30	A <sub>0</sub> ~A <sub>17</sub>	—	Z	1	A	1
31	A <sub>14</sub> /TOUT	A <sub>14</sub>	Z	1	A	1
		TOUT	Z	OUT	H	H
34~41	D <sub>0</sub> ~D <sub>7</sub>	—	Z	Z	A	Z
42	RTS <sub>0</sub>	—	1	H	OUT	H
43	CTS <sub>0</sub>	—	IN (N)	IN (A)	IN (N)	IN (N)
44	DCD <sub>0</sub>	—	IN (N)	IN (A)	IN (N)	IN (N)
45	TXA <sub>0</sub>	—	1	OUT	H	H
46	RXA <sub>0</sub>	—	IN (N)	IN (A)	IN (N)	IN (N)
47	CKA <sub>0</sub> /DREQ <sub>0</sub>	CKA <sub>0</sub> (internal clock mode)	Z	OUT	Z	Z
		CKA <sub>0</sub> (external clock mode)	Z	IN (A)	IN (N)	IN (N)
		DREQ <sub>0</sub>	Z	IN (N)	IN (A)	IN (N)
48	TXA <sub>1</sub>	—	1	OUT	H	H
49	RXA <sub>1</sub>	—	IN (N)	IN (A)	IN (N)	IN (N)
50	CKA <sub>1</sub> /TEND <sub>0</sub>	CKA <sub>1</sub> (internal clock mode)	Z	OUT	Z	Z
		CKA <sub>1</sub> (external clock mode)	Z	IN (A)	IN (N)	IN (N)
		TEND <sub>0</sub>	Z	1	OUT	1
51	TXS	—	1	OUT	H	H
52	RXS/CTS <sub>1</sub>	RXS	IN (N)	IN (A)	IN (N)	IN (N)
		CTS <sub>1</sub>	IN (N)	IN (A)	IN (N)	IN (N)
53	CKS	CKS (internal clock mode)	Z	OUT	1	1
		CKS (external clock mode)	Z	IN (A)	Z	Z
54	DREQ <sub>1</sub>	—	IN (N)	IN (N)	IN (A)	IN (N)
55	TEND <sub>1</sub>	—	1	1	OUT	1
56	HALT	—	1	0	OUT	0
57	REF	—	1	1	OUT	1
58	IOE	—	1	1	OUT	1
59	ME	—	1	1	OUT	1
60	E	—	0	E clock output	—	—
61	LR	—	1	1	OUT	1
62	WR	—	1	1	OUT	1
63	RD	—	1	1	OUT	1
64	φ	—	φ clock output	—	—	—

1: HIGH 0: LOW A: Programmable Z: High Impedance  
 IN (A): Input (Active) IN (N): Input (Not active) OUT: Output  
 H: Holds the previous state  
 —: same as the left

**28 INTERNAL I/O REGISTERS**

By programming IOA7 and IOA6 in the I/O control register, in-

ternal I/O register addresses are relocatable within ranges from 0000H to 00FFH in the I/O address space.

REGISTER	MNEMONICS	ADDRESS	REMARKS																											
ASCI Control Register A Channel 0 : CNTLA0		0 0	<table border="1"> <tr> <td>bit</td> <td>MPE</td> <td>RE</td> <td>TE</td> <td>RTS0</td> <td>MPBR/EFR</td> <td>MOD2</td> <td>MOD1</td> <td>MOD0</td> </tr> <tr> <td>during RESET</td> <td>0</td> <td>0</td> <td>0</td> <td>1</td> <td>invalid</td> <td>0</td> <td>0</td> <td>0</td> </tr> <tr> <td>R/W</td> <td>R/W</td> <td>R/W</td> <td>R/W</td> <td>R/W</td> <td>R/W</td> <td>R/W</td> <td>R/W</td> <td>R/W</td> </tr> </table> <p>                     MODE Selection                      Multi Processor Bit Receive/ Error Flag Reset                      Request To Send                      Transmit Enable                      Receive Enable                      Multi Processor Enable                 </p>	bit	MPE	RE	TE	RTS0	MPBR/EFR	MOD2	MOD1	MOD0	during RESET	0	0	0	1	invalid	0	0	0	R/W	R/W	R/W	R/W	R/W	R/W	R/W	R/W	R/W
		bit	MPE	RE	TE	RTS0	MPBR/EFR	MOD2	MOD1	MOD0																				
during RESET	0	0	0	1	invalid	0	0	0																						
R/W	R/W	R/W	R/W	R/W	R/W	R/W	R/W	R/W																						
ASCI Control Register A Channel 1 : CNTLA1		0 1	<table border="1"> <tr> <td>bit</td> <td>MPE</td> <td>RE</td> <td>TE</td> <td>CKA1D</td> <td>MPBR/EFR</td> <td>MOD2</td> <td>MOD1</td> <td>MOD0</td> </tr> <tr> <td>during RESET</td> <td>0</td> <td>0</td> <td>0</td> <td>1</td> <td>invalid</td> <td>0</td> <td>0</td> <td>0</td> </tr> <tr> <td>R/W</td> <td>R/W</td> <td>R/W</td> <td>R/W</td> <td>R/W</td> <td>R/W</td> <td>R/W</td> <td>R/W</td> <td>R/W</td> </tr> </table> <p>                     MODE Selection                      Multi Processor Bit Receive/ Error Flag Reset                      CKA1 Disable                      Transmit Enable                      Receive Enable                      Multi Processor Enable                 </p> <p>                     MOD2, 1, 0                      0 0 0 Start + 7 bit Data + 1 Stop                      0 0 1 Start + 7 bit Data + 2 Stop                      0 1 0 Start + 7 bit Data + Parity + 1 Stop                      0 1 1 Start + 7 bit Data + Parity + 2 Stop                      1 0 0 Start + 8 bit Data + 1 Stop                      1 0 1 Start + 8 bit Data + 2 Stop                      1 1 0 Start + 8 bit Data + Parity + 1 Stop                      1 1 1 Start + 8 bit Data + Parity + 2 Stop                 </p>	bit	MPE	RE	TE	CKA1D	MPBR/EFR	MOD2	MOD1	MOD0	during RESET	0	0	0	1	invalid	0	0	0	R/W	R/W	R/W	R/W	R/W	R/W	R/W	R/W	R/W
		bit	MPE	RE	TE	CKA1D	MPBR/EFR	MOD2	MOD1	MOD0																				
during RESET	0	0	0	1	invalid	0	0	0																						
R/W	R/W	R/W	R/W	R/W	R/W	R/W	R/W	R/W																						
ASCI Control Register B Channel 0 : CNTLB0		0 2	<table border="1"> <tr> <td>bit</td> <td>MPBT</td> <td>MP</td> <td>CTS/PS</td> <td>PEO</td> <td>DR</td> <td>SS2</td> <td>SS1</td> <td>SS0</td> </tr> <tr> <td>during RESET</td> <td>invalid</td> <td>0</td> <td>.</td> <td>0</td> <td>0</td> <td>1</td> <td>1</td> <td>1</td> </tr> <tr> <td>R/W</td> <td>R/W</td> <td>R/W</td> <td>R/W</td> <td>R/W</td> <td>R/W</td> <td>R/W</td> <td>R/W</td> <td>R/W</td> </tr> </table> <p>                     Clock Source and Speed Select                      Divide Ratio                      Parity Even or Odd                      Clear To Send/Prescale                      Multi Processor                      Multi Processor Bit Transmit                 </p> <p>                     * CTS : Depending on the condition of CTS Pin.                      PS : Cleared to 0.                 </p>	bit	MPBT	MP	CTS/PS	PEO	DR	SS2	SS1	SS0	during RESET	invalid	0	.	0	0	1	1	1	R/W	R/W	R/W	R/W	R/W	R/W	R/W	R/W	R/W
		bit	MPBT	MP	CTS/PS	PEO	DR	SS2	SS1	SS0																				
during RESET	invalid	0	.	0	0	1	1	1																						
R/W	R/W	R/W	R/W	R/W	R/W	R/W	R/W	R/W																						

(to be continued)

REGISTER	MNEMONICS	ADDRESS	REMARKS																																																																																					
ASCI Control Register B Channel 1 : CNTLB1		0 3	<table border="1"> <tr> <td>bit</td> <td>MPBT</td> <td>MP</td> <td>CTS/ PS</td> <td>PEO</td> <td>DR</td> <td>SS2</td> <td>SS1</td> <td>SS0</td> </tr> <tr> <td>during RESET</td> <td>invalid</td> <td>0</td> <td>0</td> <td>0</td> <td>0</td> <td>1</td> <td>1</td> <td>1</td> </tr> <tr> <td>R/W</td> <td>R/W</td> <td>R/W</td> <td>R/W</td> <td>R/W</td> <td>R/W</td> <td>R/W</td> <td>R/W</td> <td>R/W</td> </tr> </table> <p>                     Multi Processor Bit Transmit                      Multi Processor                      Clear To Send/Prescale                      Parity Even or Odd                      Divide Ratio                      Clock Source and Speed Select                 </p> <table border="1"> <tr> <td rowspan="2">General divide ratio</td> <td colspan="2">PS=0 (divide ratio=10)</td> <td colspan="2">PS=1 (divide ratio=30)</td> </tr> <tr> <td>SS2,1,0</td> <td>DR=0 (×16)</td> <td>DR=1 (×64)</td> <td>DR=0 (×16)</td> <td>DR=1 (×64)</td> </tr> <tr> <td>000</td> <td><math>\phi + 160</math></td> <td><math>\phi + 640</math></td> <td><math>\phi + 480</math></td> <td><math>\phi + 1920</math></td> <td><math>\phi + 3840</math></td> </tr> <tr> <td>001</td> <td>+ 320</td> <td>+ 1280</td> <td>+ 960</td> <td>+ 3840</td> <td>+ 7680</td> </tr> <tr> <td>010</td> <td>+ 640</td> <td>+ 2560</td> <td>+ 1920</td> <td>+ 7680</td> <td>+ 15360</td> </tr> <tr> <td>011</td> <td>+ 1280</td> <td>+ 5120</td> <td>+ 3840</td> <td>+ 15360</td> <td>+ 30720</td> </tr> <tr> <td>100</td> <td>+ 2560</td> <td>+ 10240</td> <td>+ 7680</td> <td>+ 30720</td> <td>+ 61440</td> </tr> <tr> <td>101</td> <td>+ 5120</td> <td>+ 20480</td> <td>+ 15360</td> <td>+ 61440</td> <td>+ 122880</td> </tr> <tr> <td>110</td> <td>+ 10240</td> <td>+ 40960</td> <td>+ 30720</td> <td>+ 122880</td> <td></td> </tr> <tr> <td>111</td> <td colspan="5">External clock (frequency &lt; <math>\phi + 40</math>)</td> </tr> </table>	bit	MPBT	MP	CTS/ PS	PEO	DR	SS2	SS1	SS0	during RESET	invalid	0	0	0	0	1	1	1	R/W	R/W	R/W	R/W	R/W	R/W	R/W	R/W	R/W	General divide ratio	PS=0 (divide ratio=10)		PS=1 (divide ratio=30)		SS2,1,0	DR=0 (×16)	DR=1 (×64)	DR=0 (×16)	DR=1 (×64)	000	$\phi + 160$	$\phi + 640$	$\phi + 480$	$\phi + 1920$	$\phi + 3840$	001	+ 320	+ 1280	+ 960	+ 3840	+ 7680	010	+ 640	+ 2560	+ 1920	+ 7680	+ 15360	011	+ 1280	+ 5120	+ 3840	+ 15360	+ 30720	100	+ 2560	+ 10240	+ 7680	+ 30720	+ 61440	101	+ 5120	+ 20480	+ 15360	+ 61440	+ 122880	110	+ 10240	+ 40960	+ 30720	+ 122880		111	External clock (frequency < $\phi + 40$ )				
			bit	MPBT	MP	CTS/ PS	PEO	DR	SS2	SS1	SS0																																																																													
during RESET	invalid	0	0	0	0	1	1	1																																																																																
R/W	R/W	R/W	R/W	R/W	R/W	R/W	R/W	R/W																																																																																
General divide ratio	PS=0 (divide ratio=10)		PS=1 (divide ratio=30)																																																																																					
	SS2,1,0	DR=0 (×16)	DR=1 (×64)	DR=0 (×16)	DR=1 (×64)																																																																																			
000	$\phi + 160$	$\phi + 640$	$\phi + 480$	$\phi + 1920$	$\phi + 3840$																																																																																			
001	+ 320	+ 1280	+ 960	+ 3840	+ 7680																																																																																			
010	+ 640	+ 2560	+ 1920	+ 7680	+ 15360																																																																																			
011	+ 1280	+ 5120	+ 3840	+ 15360	+ 30720																																																																																			
100	+ 2560	+ 10240	+ 7680	+ 30720	+ 61440																																																																																			
101	+ 5120	+ 20480	+ 15360	+ 61440	+ 122880																																																																																			
110	+ 10240	+ 40960	+ 30720	+ 122880																																																																																				
111	External clock (frequency < $\phi + 40$ )																																																																																							
ASCI Status Register Channel 0 : STAT0		0 4	<table border="1"> <tr> <td>bit</td> <td>RDRF</td> <td>OVRN</td> <td>PE</td> <td>FE</td> <td>RIE</td> <td>DCD<sub>0</sub></td> <td>TDRE</td> <td>TIE</td> </tr> <tr> <td>during RESET</td> <td>0</td> <td>0</td> <td>0</td> <td>0</td> <td>0</td> <td>*</td> <td>**</td> <td>0</td> </tr> <tr> <td>R/W</td> <td>R</td> <td>R</td> <td>R</td> <td>R</td> <td>R/W</td> <td>R</td> <td>R</td> <td>R/W</td> </tr> </table> <p>                     Receive Data Register Full                      Over Run Error                      Parity Error                      Framing Error                      Receive Interrupt Enable                      Data Carrier Detect                      Transmit Data Register Empty                      Transmit Interrupt Enable                      * DCD<sub>0</sub> : Depending on the condition of DCD<sub>0</sub> Pin.                      ** CTS<sub>0</sub> Pin                 </p> <table border="1"> <tr> <td>CTS<sub>0</sub> Pin</td> <td>TDRE</td> </tr> <tr> <td>L</td> <td>1</td> </tr> <tr> <td>H</td> <td>0</td> </tr> </table>	bit	RDRF	OVRN	PE	FE	RIE	DCD <sub>0</sub>	TDRE	TIE	during RESET	0	0	0	0	0	*	**	0	R/W	R	R	R	R	R/W	R	R	R/W	CTS <sub>0</sub> Pin	TDRE	L	1	H	0																																																				
			bit	RDRF	OVRN	PE	FE	RIE	DCD <sub>0</sub>	TDRE	TIE																																																																													
during RESET	0	0	0	0	0	*	**	0																																																																																
R/W	R	R	R	R	R/W	R	R	R/W																																																																																
CTS <sub>0</sub> Pin	TDRE																																																																																							
L	1																																																																																							
H	0																																																																																							
ASCI Status Register Channel 1 : STAT1		0 5	<table border="1"> <tr> <td>bit</td> <td>RDRF</td> <td>OVRN</td> <td>PE</td> <td>FE</td> <td>RIE</td> <td>CTS1E</td> <td>TDRE</td> <td>TIE</td> </tr> <tr> <td>during RESET</td> <td>0</td> <td>0</td> <td>0</td> <td>0</td> <td>0</td> <td>0</td> <td>1</td> <td>0</td> </tr> <tr> <td>R/W</td> <td>R</td> <td>R</td> <td>R</td> <td>R</td> <td>R/W</td> <td>R/W</td> <td>R</td> <td>R/W</td> </tr> </table> <p>                     Receive Data Register Full                      Over Run Error                      Parity Error                      Framing Error                      Receive Interrupt Enable                      CTS1 Enable                      Transmit Data Register Empty                      Transmit Interrupt Enable                 </p>	bit	RDRF	OVRN	PE	FE	RIE	CTS1E	TDRE	TIE	during RESET	0	0	0	0	0	0	1	0	R/W	R	R	R	R	R/W	R/W	R	R/W																																																										
			bit	RDRF	OVRN	PE	FE	RIE	CTS1E	TDRE	TIE																																																																													
during RESET	0	0	0	0	0	0	1	0																																																																																
R/W	R	R	R	R	R/W	R/W	R	R/W																																																																																



REGISTER	MNEMONICS	ADDRESS	REMARKS																																												
ASCII Transmit Data Register Channel 0	: TDR0	0 6	<p>bit</p> <table border="1"> <tr> <td>EF</td> <td>EIE</td> <td>RE</td> <td>TE</td> <td>—</td> <td>SS2</td> <td>SS1</td> <td>SS0</td> </tr> <tr> <td>0</td> <td>0</td> <td>0</td> <td>0</td> <td>1</td> <td>1</td> <td>1</td> <td>1</td> </tr> <tr> <td>R/W</td> <td>R/W</td> <td>R/W</td> <td>R/W</td> <td></td> <td>R/W</td> <td>R/W</td> <td>R/W</td> </tr> </table> <p>                     — End Flag                      — End Interrupt Enable                      — Receive Enable                      — Transmit Enable                      — Speed Select                 </p> <table border="1"> <thead> <tr> <th>SS2,1,0</th> <th>Baud Rate</th> <th>SS2,1,0</th> <th>Baud Rate</th> </tr> </thead> <tbody> <tr> <td>000</td> <td><math>\phi + 20</math></td> <td>100</td> <td><math>\phi + 320</math></td> </tr> <tr> <td>001</td> <td>+ 40</td> <td>101</td> <td>+ 640</td> </tr> <tr> <td>010</td> <td>+ 80</td> <td>110</td> <td>+ 1280</td> </tr> <tr> <td>011</td> <td>+ 160</td> <td>111</td> <td>External (frequency &lt; + 20)</td> </tr> </tbody> </table>	EF	EIE	RE	TE	—	SS2	SS1	SS0	0	0	0	0	1	1	1	1	R/W	R/W	R/W	R/W		R/W	R/W	R/W	SS2,1,0	Baud Rate	SS2,1,0	Baud Rate	000	$\phi + 20$	100	$\phi + 320$	001	+ 40	101	+ 640	010	+ 80	110	+ 1280	011	+ 160	111	External (frequency < + 20)
EF	EIE	RE		TE	—	SS2	SS1	SS0																																							
0	0	0		0	1	1	1	1																																							
R/W	R/W	R/W		R/W		R/W	R/W	R/W																																							
SS2,1,0	Baud Rate	SS2,1,0		Baud Rate																																											
000	$\phi + 20$	100		$\phi + 320$																																											
001	+ 40	101		+ 640																																											
010	+ 80	110		+ 1280																																											
011	+ 160	111		External (frequency < + 20)																																											
ASCII Transmit Data Register Channel 1	: TDR1	0 7																																													
ASCII Receive Data Register Channel 0	: TSRO	0 8																																													
ASCII Receive Data Register Channel 1	: TSR1	0 9																																													
CS/O Control Register	: CNTR	0 A																																													
CS/O Transmit/Receive Data Register	: TRDR	0 B																																													
Timer Data Register Channel 0L	: TMDROL	0 C																																													
Timer Data Register Channel 0H	: TMDROH	0 D																																													
Timer Reload Register Channel 0L	: RLDROL	0 E																																													
Timer Reload Register Channel 0H	: RLDROH	0 F																																													
Timer Control Register	: TCR	1 0	<p>bit</p> <table border="1"> <tr> <td>TIF1</td> <td>TIFO</td> <td>TIE1</td> <td>TIE0</td> <td>TOC1</td> <td>TOC0</td> <td>TDE1</td> <td>TDE0</td> </tr> <tr> <td>0</td> <td>0</td> <td>0</td> <td>0</td> <td>0</td> <td>0</td> <td>0</td> <td>0</td> </tr> <tr> <td>R</td> <td>R</td> <td>R/W</td> <td>R/W</td> <td>R/W</td> <td>R/W</td> <td>R/W</td> <td>R/W</td> </tr> </table> <p>                     — Timer Interrupt Flag 1,0                      — Timer Interrupt Enable 1,0                      — Timer Output Control 1,0                      — Timer Down Count Enable 1,0                 </p> <table border="1"> <thead> <tr> <th>TOC1,0</th> <th>A<sub>12</sub>/TOUT</th> </tr> </thead> <tbody> <tr> <td>00</td> <td>Inhibited</td> </tr> <tr> <td>01</td> <td>Toggle</td> </tr> <tr> <td>10</td> <td>0</td> </tr> <tr> <td>11</td> <td>1</td> </tr> </tbody> </table>	TIF1	TIFO	TIE1	TIE0	TOC1	TOC0	TDE1	TDE0	0	0	0	0	0	0	0	0	R	R	R/W	R/W	R/W	R/W	R/W	R/W	TOC1,0	A <sub>12</sub> /TOUT	00	Inhibited	01	Toggle	10	0	11	1										
TIF1	TIFO	TIE1	TIE0	TOC1	TOC0	TDE1	TDE0																																								
0	0	0	0	0	0	0	0																																								
R	R	R/W	R/W	R/W	R/W	R/W	R/W																																								
TOC1,0	A <sub>12</sub> /TOUT																																														
00	Inhibited																																														
01	Toggle																																														
10	0																																														
11	1																																														

# HD64180R/Z

REGISTER	MNEMONICS	ADDRESS	REMARKS																				
Timer Data Register Channel 1L : TMDR1L		1 4																					
Timer Data Register Channel 1H : TMDR1H		1 5																					
Timer Reload Register Channel 1L : RLDR1L		1 6																					
Timer Reload Register Channel 1H : RLDR1H		1 7																					
Free Running Counter : FRC		1 8	read only																				
DMA Source Address Register Channel 0L : SAR0L		2 0																					
DMA Source Address Register Channel 0H : SAR0H		2 1																					
DMA Source Address Register Channel 0B : SAR0B		2 2	Bits 0-2 are used for SAR0B. <table border="1" style="margin-left: auto; margin-right: auto;"> <thead> <tr> <th>A<sub>16</sub></th> <th>A<sub>17</sub></th> <th>A<sub>18</sub></th> <th>DMA Transfer Request</th> </tr> </thead> <tbody> <tr> <td>X</td> <td>0</td> <td>0</td> <td>DREQ<sub>0</sub> (external)</td> </tr> <tr> <td>X</td> <td>0</td> <td>1</td> <td>RDR0 (ASCI0)</td> </tr> <tr> <td>X</td> <td>1</td> <td>0</td> <td>RDR1 (ASCI1)</td> </tr> <tr> <td>X</td> <td>1</td> <td>1</td> <td>Not Used</td> </tr> </tbody> </table>	A <sub>16</sub>	A <sub>17</sub>	A <sub>18</sub>	DMA Transfer Request	X	0	0	DREQ <sub>0</sub> (external)	X	0	1	RDR0 (ASCI0)	X	1	0	RDR1 (ASCI1)	X	1	1	Not Used
A <sub>16</sub>	A <sub>17</sub>	A <sub>18</sub>	DMA Transfer Request																				
X	0	0	DREQ <sub>0</sub> (external)																				
X	0	1	RDR0 (ASCI0)																				
X	1	0	RDR1 (ASCI1)																				
X	1	1	Not Used																				
DMA Destination Address Register Channel 0L : DAR0L		2 3																					
DMA Destination Address Register Channel 0H : DAR0H		2 4																					
DMA Destination Address Register Channel 0B : DAR0B		2 5	Bits 0-2 are used for DAR0B. <table border="1" style="margin-left: auto; margin-right: auto;"> <thead> <tr> <th>A<sub>16</sub></th> <th>A<sub>17</sub></th> <th>A<sub>18</sub></th> <th>DMA Transfer Request</th> </tr> </thead> <tbody> <tr> <td>X</td> <td>0</td> <td>0</td> <td>DREQ<sub>0</sub> (external)</td> </tr> <tr> <td>X</td> <td>0</td> <td>1</td> <td>TDR0 (ASCI0)</td> </tr> <tr> <td>X</td> <td>1</td> <td>0</td> <td>TDR1 (ASCI1)</td> </tr> <tr> <td>X</td> <td>1</td> <td>1</td> <td>Not Used</td> </tr> </tbody> </table>	A <sub>16</sub>	A <sub>17</sub>	A <sub>18</sub>	DMA Transfer Request	X	0	0	DREQ <sub>0</sub> (external)	X	0	1	TDR0 (ASCI0)	X	1	0	TDR1 (ASCI1)	X	1	1	Not Used
A <sub>16</sub>	A <sub>17</sub>	A <sub>18</sub>	DMA Transfer Request																				
X	0	0	DREQ <sub>0</sub> (external)																				
X	0	1	TDR0 (ASCI0)																				
X	1	0	TDR1 (ASCI1)																				
X	1	1	Not Used																				
DMA Byte Count Register Channel 0L : BC0L		2 6																					
DMA Byte Count Register Channel 0H : BC0H		2 7																					
DMA Memory Address Register Channel 1L : MAR1L		2 8																					
DMA Memory Address Register Channel 1H : MAR1H		2 9																					
DMA Memory Address Register Channel 1B : MAR1B		2 A	Bits 0-2 are used for MAR1B.																				
DMA I/O Address Register Channel 1L : IAR1L		2 B																					
DMA I/O Address Register Channel 1H : IAR1H		2 C																					

(to be continued)

REGISTER	MNEMONICS	ADDRESS	REMARKS																																																												
DMA Byte Count Register Channel 1L	: BCR1L	2 E	<table border="1"> <tr> <td>DE1</td> <td>DE0</td> <td>DWE1</td> <td>DWE0</td> <td>DE1</td> <td>DE0</td> <td>---</td> <td>DME</td> </tr> <tr> <td>0</td> <td>0</td> <td>1</td> <td>1</td> <td>0</td> <td>0</td> <td>1</td> <td>0</td> </tr> <tr> <td>R/W</td> <td>R/W</td> <td>W</td> <td>W</td> <td>R/W</td> <td>R/W</td> <td></td> <td>R</td> </tr> </table> <p>bit during RESET</p> <p>DMA Master Enable</p> <p>DMA Interrupt Enable 1,0</p> <p>DMA Enable Bit Write Enable 1,0</p> <p>DMA Enable ch 1,0</p>	DE1	DE0	DWE1	DWE0	DE1	DE0	---	DME	0	0	1	1	0	0	1	0	R/W	R/W	W	W	R/W	R/W		R																																				
DE1	DE0	DWE1		DWE0	DE1	DE0	---	DME																																																							
0	0	1		1	0	0	1	0																																																							
R/W	R/W	W	W	R/W	R/W		R																																																								
DMA Byte Count Register Channel 1H	: BCR1H	2 F																																																													
DMA Status Register	: DSTAT	3 0																																																													
DMA Mode Register	: DMODE	3 1	<table border="1"> <tr> <td>---</td> <td>---</td> <td>DM1</td> <td>DM0</td> <td>SM1</td> <td>SM0</td> <td>MMOD</td> <td>---</td> </tr> <tr> <td>1</td> <td>1</td> <td>0</td> <td>0</td> <td>0</td> <td>0</td> <td>0</td> <td>1</td> </tr> <tr> <td></td> <td></td> <td>R/W</td> <td>R/W</td> <td>R/W</td> <td>R/W</td> <td>R/W</td> <td></td> </tr> </table> <p>bit during RESET</p> <p>Memory MODE Select</p> <p>Ch 0 Source Mode 1,0</p> <p>Ch 0 Destination Mode 1,0</p> <table border="1"> <thead> <tr> <th>DM1, 0</th> <th>Destination</th> <th>Address</th> <th>SM1, 0</th> <th>Source</th> <th>Address</th> </tr> </thead> <tbody> <tr> <td>0 0</td> <td>M</td> <td>DAR0+1</td> <td>0 0</td> <td>M</td> <td>SAR0+1</td> </tr> <tr> <td>0 1</td> <td>M</td> <td>DAR0-1</td> <td>0 1</td> <td>M</td> <td>SAR0-1</td> </tr> <tr> <td>1 0</td> <td>M</td> <td>DAR0 fixed</td> <td>1 0</td> <td>M</td> <td>SAR0 fixed</td> </tr> <tr> <td>1 1</td> <td>I/O</td> <td>DAR0 fixed</td> <td>1 1</td> <td>I/O</td> <td>SAR0 fixed</td> </tr> </tbody> </table> <table border="1"> <thead> <tr> <th>MMOD</th> <th>Mode</th> </tr> </thead> <tbody> <tr> <td>0</td> <td>Cycle Steal Mode</td> </tr> <tr> <td>1</td> <td>Burst Mode</td> </tr> </tbody> </table>	---	---	DM1	DM0	SM1	SM0	MMOD	---	1	1	0	0	0	0	0	1			R/W	R/W	R/W	R/W	R/W		DM1, 0	Destination	Address	SM1, 0	Source	Address	0 0	M	DAR0+1	0 0	M	SAR0+1	0 1	M	DAR0-1	0 1	M	SAR0-1	1 0	M	DAR0 fixed	1 0	M	SAR0 fixed	1 1	I/O	DAR0 fixed	1 1	I/O	SAR0 fixed	MMOD	Mode	0	Cycle Steal Mode	1	Burst Mode
---	---	DM1	DM0	SM1	SM0	MMOD	---																																																								
1	1	0	0	0	0	0	1																																																								
		R/W	R/W	R/W	R/W	R/W																																																									
DM1, 0	Destination	Address	SM1, 0	Source	Address																																																										
0 0	M	DAR0+1	0 0	M	SAR0+1																																																										
0 1	M	DAR0-1	0 1	M	SAR0-1																																																										
1 0	M	DAR0 fixed	1 0	M	SAR0 fixed																																																										
1 1	I/O	DAR0 fixed	1 1	I/O	SAR0 fixed																																																										
MMOD	Mode																																																														
0	Cycle Steal Mode																																																														
1	Burst Mode																																																														

(to be continued)

REGISTER	MNEMONICS	ADDRESS	REMARKS																																																																									
DMA/WAIT Control Register	: DCNTL	3 2	<table border="1"> <tr> <td>bit</td> <td>MW/1</td> <td>MW/0</td> <td>M/1</td> <td>M/0</td> <td>DMS1</td> <td>DMS0</td> <td>DIM1</td> <td>DIM0</td> </tr> <tr> <td>during RESET</td> <td>1</td> <td>1</td> <td>1</td> <td>1</td> <td>0</td> <td>0</td> <td>0</td> <td>0</td> </tr> <tr> <td>R/W</td> <td>R/W</td> <td>R/W</td> <td>R/W</td> <td>R/W</td> <td>R/W</td> <td>R/W</td> <td>R/W</td> <td>R/W</td> </tr> </table> <p>                     I/O Wait Insertion                      Memory Wait Insertion                      DMA Ch 1 I/O Memory Mode Select                      DREQ<sub>i</sub> Select, i = 1,0                 </p> <table border="1"> <tr> <td>MW1,0</td> <td>The number of wait states</td> <td>M/1,0</td> <td>The number of wait states</td> </tr> <tr> <td>00</td> <td>0</td> <td>00</td> <td>0</td> </tr> <tr> <td>01</td> <td>1</td> <td>01</td> <td>2</td> </tr> <tr> <td>10</td> <td>2</td> <td>10</td> <td>3</td> </tr> <tr> <td>11</td> <td>3</td> <td>11</td> <td>4</td> </tr> </table> <table border="1"> <tr> <td>DMS<sub>i</sub></td> <td>Sense</td> </tr> <tr> <td>1</td> <td>Edge sense</td> </tr> <tr> <td>0</td> <td>Level sense</td> </tr> </table> <table border="1"> <tr> <td>DIM1,0</td> <td>Transfer Mode</td> <td colspan="2">Address Increment/Decrement</td> </tr> <tr> <td>00</td> <td>M→I/O</td> <td>MAR1+1</td> <td>IAR1 fixed</td> </tr> <tr> <td>01</td> <td>M→I/O</td> <td>MAR1-1</td> <td>IAR1 fixed</td> </tr> <tr> <td>10</td> <td>I/O→M</td> <td>IAR1 fixed</td> <td>MAR1+1</td> </tr> <tr> <td>11</td> <td>I/O→M</td> <td>IAR1 fixed</td> <td>MAR1-1</td> </tr> </table>	bit	MW/1	MW/0	M/1	M/0	DMS1	DMS0	DIM1	DIM0	during RESET	1	1	1	1	0	0	0	0	R/W	R/W	R/W	R/W	R/W	R/W	R/W	R/W	R/W	MW1,0	The number of wait states	M/1,0	The number of wait states	00	0	00	0	01	1	01	2	10	2	10	3	11	3	11	4	DMS <sub>i</sub>	Sense	1	Edge sense	0	Level sense	DIM1,0	Transfer Mode	Address Increment/Decrement		00	M→I/O	MAR1+1	IAR1 fixed	01	M→I/O	MAR1-1	IAR1 fixed	10	I/O→M	IAR1 fixed	MAR1+1	11	I/O→M	IAR1 fixed	MAR1-1
bit	MW/1	MW/0	M/1	M/0	DMS1	DMS0	DIM1	DIM0																																																																				
during RESET	1	1	1	1	0	0	0	0																																																																				
R/W	R/W	R/W	R/W	R/W	R/W	R/W	R/W	R/W																																																																				
MW1,0	The number of wait states	M/1,0	The number of wait states																																																																									
00	0	00	0																																																																									
01	1	01	2																																																																									
10	2	10	3																																																																									
11	3	11	4																																																																									
DMS <sub>i</sub>	Sense																																																																											
1	Edge sense																																																																											
0	Level sense																																																																											
DIM1,0	Transfer Mode	Address Increment/Decrement																																																																										
00	M→I/O	MAR1+1	IAR1 fixed																																																																									
01	M→I/O	MAR1-1	IAR1 fixed																																																																									
10	I/O→M	IAR1 fixed	MAR1+1																																																																									
11	I/O→M	IAR1 fixed	MAR1-1																																																																									
Interrupt Vector Low Register	: IL	3 3	<table border="1"> <tr> <td>bit</td> <td>IL7</td> <td>IL6</td> <td>IL5</td> <td>-</td> <td>-</td> <td>-</td> <td>-</td> <td>-</td> </tr> <tr> <td>during RESET</td> <td>0</td> <td>0</td> <td>0</td> <td>0</td> <td>0</td> <td>0</td> <td>0</td> <td>0</td> </tr> <tr> <td>R/W</td> <td>R/W</td> <td>R/W</td> <td>R/W</td> <td></td> <td></td> <td></td> <td></td> <td></td> </tr> </table> <p>Interrupt Vector Low</p>	bit	IL7	IL6	IL5	-	-	-	-	-	during RESET	0	0	0	0	0	0	0	0	R/W	R/W	R/W	R/W																																																			
bit	IL7	IL6	IL5	-	-	-	-	-																																																																				
during RESET	0	0	0	0	0	0	0	0																																																																				
R/W	R/W	R/W	R/W																																																																									
INT/TRAP Control Register	: ITC	3 4	<table border="1"> <tr> <td>bit</td> <td>TRAP</td> <td>UFO</td> <td>-</td> <td>-</td> <td>-</td> <td>ITE2</td> <td>ITE1</td> <td>ITE0</td> </tr> <tr> <td>during RESET</td> <td>0</td> <td>0</td> <td>1</td> <td>1</td> <td>1</td> <td>0</td> <td>0</td> <td>1</td> </tr> <tr> <td>R/W</td> <td>R/W</td> <td>R</td> <td></td> <td></td> <td></td> <td>R/W</td> <td>R/W</td> <td>R/W</td> </tr> </table> <p>                     TRAP                      Undefined Fetch Object                      INT Enable 2,1,0                 </p>	bit	TRAP	UFO	-	-	-	ITE2	ITE1	ITE0	during RESET	0	0	1	1	1	0	0	1	R/W	R/W	R				R/W	R/W	R/W																																														
bit	TRAP	UFO	-	-	-	ITE2	ITE1	ITE0																																																																				
during RESET	0	0	1	1	1	0	0	1																																																																				
R/W	R/W	R				R/W	R/W	R/W																																																																				
Refresh Control Register	: RCR	3 6	<table border="1"> <tr> <td>bit</td> <td>REFE</td> <td>REFW</td> <td>-</td> <td>-</td> <td>-</td> <td>-</td> <td>CYC1</td> <td>CYC0</td> </tr> <tr> <td>during RESET</td> <td>1</td> <td>1</td> <td>1</td> <td>1</td> <td>1</td> <td>1</td> <td>0</td> <td>0</td> </tr> <tr> <td>R/W</td> <td>R/W</td> <td>R/W</td> <td></td> <td></td> <td></td> <td></td> <td>R/W</td> <td>R/W</td> </tr> </table> <p>                     Refresh Wait State                      Refresh Enable                      Cycle Select                 </p> <table border="1"> <tr> <td>CYC1,0</td> <td>Interval of Refresh Cycle</td> </tr> <tr> <td>00</td> <td>10 States</td> </tr> <tr> <td>01</td> <td>20</td> </tr> <tr> <td>10</td> <td>40</td> </tr> <tr> <td>11</td> <td>80</td> </tr> </table>	bit	REFE	REFW	-	-	-	-	CYC1	CYC0	during RESET	1	1	1	1	1	1	0	0	R/W	R/W	R/W					R/W	R/W	CYC1,0	Interval of Refresh Cycle	00	10 States	01	20	10	40	11	80																																				
bit	REFE	REFW	-	-	-	-	CYC1	CYC0																																																																				
during RESET	1	1	1	1	1	1	0	0																																																																				
R/W	R/W	R/W					R/W	R/W																																																																				
CYC1,0	Interval of Refresh Cycle																																																																											
00	10 States																																																																											
01	20																																																																											
10	40																																																																											
11	80																																																																											

(to be continued)

REGISTER	MNEMONICS	ADDRESS	REMARKS																											
MMU Common Base Register	: CBR	3 8	<table border="1"> <tr> <td>bit</td> <td>—</td> <td>CB6</td> <td>CB5</td> <td>CB4</td> <td>CB3</td> <td>CB2</td> <td>CB1</td> <td>CB0</td> </tr> <tr> <td>during RESET</td> <td>0</td> <td>0</td> <td>0</td> <td>0</td> <td>0</td> <td>0</td> <td>0</td> <td>0</td> </tr> <tr> <td>R/W</td> <td>R/W</td> <td>R/W</td> <td>R/W</td> <td>R/W</td> <td>R/W</td> <td>R/W</td> <td>R/W</td> <td>R/W</td> </tr> </table> <p style="text-align: center;">MMU Common Base Register</p>	bit	—	CB6	CB5	CB4	CB3	CB2	CB1	CB0	during RESET	0	0	0	0	0	0	0	0	R/W	R/W	R/W	R/W	R/W	R/W	R/W	R/W	R/W
bit	—	CB6	CB5	CB4	CB3	CB2	CB1	CB0																						
during RESET	0	0	0	0	0	0	0	0																						
R/W	R/W	R/W	R/W	R/W	R/W	R/W	R/W	R/W																						
MMU Bank Base Register	: BBR	3 9	<table border="1"> <tr> <td>bit</td> <td>—</td> <td>BB6</td> <td>BB5</td> <td>BB4</td> <td>BB3</td> <td>BB2</td> <td>BB1</td> <td>BB0</td> </tr> <tr> <td>during RESET</td> <td>0</td> <td>0</td> <td>0</td> <td>0</td> <td>0</td> <td>0</td> <td>0</td> <td>0</td> </tr> <tr> <td>R/W</td> <td>R/W</td> <td>R/W</td> <td>R/W</td> <td>R/W</td> <td>R/W</td> <td>R/W</td> <td>R/W</td> <td>R/W</td> </tr> </table> <p style="text-align: center;">MMU Bank Base Register</p>	bit	—	BB6	BB5	BB4	BB3	BB2	BB1	BB0	during RESET	0	0	0	0	0	0	0	0	R/W	R/W	R/W	R/W	R/W	R/W	R/W	R/W	R/W
bit	—	BB6	BB5	BB4	BB3	BB2	BB1	BB0																						
during RESET	0	0	0	0	0	0	0	0																						
R/W	R/W	R/W	R/W	R/W	R/W	R/W	R/W	R/W																						
MMU Common/Bank Area Register	: CBAR	3 A	<table border="1"> <tr> <td>bit</td> <td>CA3</td> <td>CA2</td> <td>CA1</td> <td>CA0</td> <td>BA3</td> <td>BA2</td> <td>BA1</td> <td>BA0</td> </tr> <tr> <td>during RESET</td> <td>1</td> <td>1</td> <td>1</td> <td>1</td> <td>0</td> <td>0</td> <td>0</td> <td>0</td> </tr> <tr> <td>R/W</td> <td>R/W</td> <td>R/W</td> <td>R/W</td> <td>R/W</td> <td>R/W</td> <td>R/W</td> <td>R/W</td> <td>R/W</td> </tr> </table> <p style="text-align: center;">MMU Common Area Register</p> <p style="text-align: right;">MMU Bank Area Register</p>	bit	CA3	CA2	CA1	CA0	BA3	BA2	BA1	BA0	during RESET	1	1	1	1	0	0	0	0	R/W	R/W	R/W	R/W	R/W	R/W	R/W	R/W	R/W
bit	CA3	CA2	CA1	CA0	BA3	BA2	BA1	BA0																						
during RESET	1	1	1	1	0	0	0	0																						
R/W	R/W	R/W	R/W	R/W	R/W	R/W	R/W	R/W																						
I/O Control Register	: ICR	3 F	<table border="1"> <tr> <td>bit</td> <td>IOA7</td> <td>IOA6</td> <td>IOSTP</td> <td>—</td> <td>—</td> <td>—</td> <td>—</td> <td>—</td> </tr> <tr> <td>during RESET</td> <td>0</td> <td>0</td> <td>0</td> <td>1</td> <td>1</td> <td>1</td> <td>1</td> <td>1</td> </tr> <tr> <td>R/W</td> <td>R/W</td> <td>R/W</td> <td>R/W</td> <td></td> <td></td> <td></td> <td></td> <td></td> </tr> </table> <p style="text-align: center;">I/O Stop</p> <p style="text-align: center;">I/O Address</p>	bit	IOA7	IOA6	IOSTP	—	—	—	—	—	during RESET	0	0	0	1	1	1	1	1	R/W	R/W	R/W	R/W					
bit	IOA7	IOA6	IOSTP	—	—	—	—	—																						
during RESET	0	0	0	1	1	1	1	1																						
R/W	R/W	R/W	R/W																											