

# QUAD MICROPOWER LinCMOS™ VOLTAGE COMPARATORS

SLCS117B – NOVEMBER 1986 – REVISED JANUARY 2002

- **Push-Pull CMOS Output Drives Capacitive Loads Without Pullup Resistor,  $I_O = \pm 8 \text{ mA}$**
- **Very Low Power . . . 200  $\mu\text{W}$  Typ at 5 V**
- **Fast Response Time . . .  $t_{PLH} = 2.7 \mu\text{s}$  Typ With 5-mV Overdrive**
- **Single Supply Operation . . . 3 V to 16 V  
TLC3704M . . . 4 V to 16 V**
- **On-Chip ESD Protection**

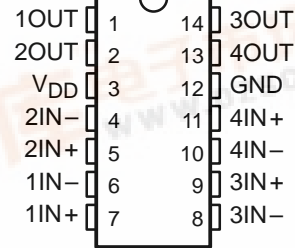
## description

The TLC3704 consists of four independent micropower voltage comparators designed to operate from a single supply and be compatible with modern HCMOS logic systems. They are functionally similar to the LM339 but use 1/20th the power for similar response times. The push-pull CMOS output stage drives capacitive loads directly without a power-consuming pullup resistor to achieve the stated response time. Eliminating the pullup resistor not only reduces power dissipation, but also saves board space and component cost. The output stage is also fully compatible with TTL requirements.

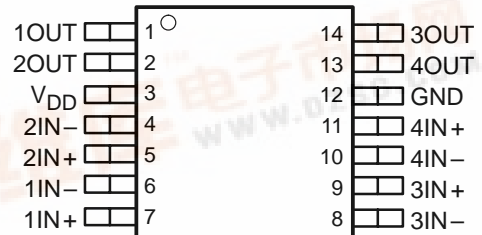
Texas Instruments LinCMOS™ process offers superior analog performance to standard CMOS processes. Along with the standard CMOS advantages of low power without sacrificing speed, high input impedance, and low bias currents, the LinCMOS process offers extremely stable input offset voltages with large differential input voltages. This characteristic makes it possible to build reliable CMOS comparators.

The TLC3704C is characterized for operation over the commercial temperature range of 0°C to 70°C. The TLC3704I is characterized for operation over the extended industrial temperature range of -40°C to 85°C. The TLC3704M is characterized for operation over the full military temperature range of -55°C to 125°C. The TLC3704Q is characterized for operation from -40°C to 125°C.

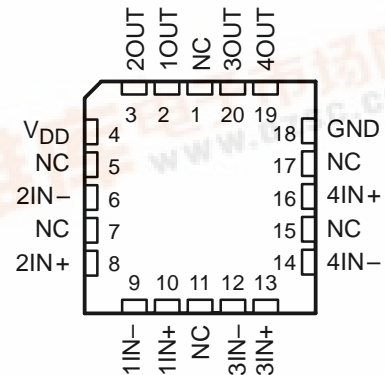
D, J, OR N PACKAGE  
(TOP VIEW)



PW PACKAGE  
(TOP VIEW)

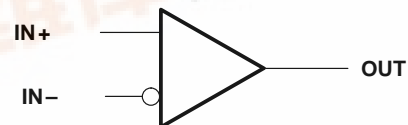


FK PACKAGE  
(TOP VIEW)



NC – No internal connection

## symbol (each comparator)



Please be aware that an important notice concerning availability, standard warranty, and use in critical applications of Texas Instruments semiconductor products and disclaimers thereto appears at the end of this data sheet.

LinCMOS is a trademark of Texas Instruments Incorporated.

PRODUCTION DATA information is current as of publication date. Products conform to specifications per the terms of Texas Instruments standard warranty. Production processing does not necessarily include testing of all parameters.

Copyright © 2002, Texas Instruments Incorporated



# TLC3704, TLC3704Q QUAD MICROPOWER LinCMOS™ VOLTAGE COMPARATORS

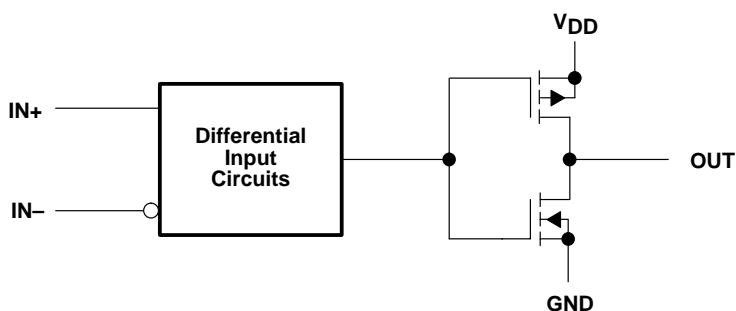
SLCS117B – NOVEMBER 1986 – REVISED JANUARY 2002

## AVAILABLE OPTIONS

T <sub>A</sub>	V <sub>IOMax</sub> at 25°C	PACKAGE				
		SMALL OUTLINE (D)	CERAMIC (FK)	CERAMIC DIP (J)	PLASTIC DIP (N)	TSSOP (PW)
0°C to 70°C	5 mV	TLC3704CD	—	—	TLC3704CN	TLC3704CPW
– 40°C to 85°C	5 mV	TLC3704ID	—	—	TLC3704IN	TLC3704IPW
– 55°C to 125°C	5 mV	—	TLC3704MFK	TLC3704MJ	—	—
– 40°C to 125°C	5 mV	—	—	TLC3704QJ	—	—

The D and PW packages are available taped and reeled. Add R suffix to the device type (e.g., TLC3704CDR).

## functional block diagram (each comparator)



## absolute maximum ratings over operating free-air temperature range (unless otherwise noted)†

Supply voltage range, V <sub>DD</sub> (see Note 1)	– 0.3 V to 18 V
Differential input voltage, V <sub>ID</sub> (see Note 2)	± 18 V
Input voltage range, V <sub>I</sub>	– 0.3 to V <sub>DD</sub>
Output voltage range, V <sub>O</sub>	– 0.3 to V <sub>DD</sub>
Input current, I <sub>I</sub>	± 5 mA
Output current, I <sub>O</sub> (each output)	± 20 mA
Total supply current into V <sub>DD</sub>	40 mA
Total current out of GND	60 mA
Continuous total power dissipation	See Dissipation Rating Table
Operating free-air temperature range, T <sub>A</sub> : TLC3704C	0 to 70°C
TLC3704I	– 40°C to 85°C
TLC3704M	– 55°C to 125°C
TLC3704Q	– 40°C to 125°C
Storage temperature range	– 65°C to 150°C
Case temperature for 60 seconds: FK package	260°C
Lead temperature 1,6 mm (1/16 inch) from case for 10 seconds: D or N package	260°C
Lead temperature 1,6 mm (1/16 inch) from case for 60 seconds: J package	300°C

† Stresses beyond those listed under “absolute maximum ratings” may cause permanent damage to the device. These are stress ratings only, and functional operation of the device at these or any other conditions beyond those indicated under “recommended operating conditions” is not implied. Exposure to absolute-maximum-rated conditions for extended periods may affect device reliability.

- NOTES: 1. All voltage values, except differential voltages, are with respect to network ground.  
2. Differential voltages are at IN+ with respect to IN–.

# TLC3704, TLC3704Q

## QUAD MICROPOWER LinCMOS™ VOLTAGE COMPARATORS

SLCS117B – NOVEMBER 1986 – REVISED JANUARY 2002

**DISSIPATION RATING TABLE**

PACKAGE	$T_A \leq 25^\circ\text{C}$ POWER RATING	DERATING FACTOR ABOVE $T_A = 25^\circ\text{C}$	$T_A = 70^\circ\text{C}$ POWER RATING	$T_A = 85^\circ\text{C}$ POWER RATING	$T_A = 125^\circ\text{C}$ POWER RATING
D	950 mW	7.6 mW/°C	608 mW	494 mW	N/A
FK	1375 mW	11.0 mW/°C	880 mW	715 mW	275 mW
J	1375 mW	11.0 mW/°C	880 mW	715 mW	275 mW
N	1150 mW	9.2 mW/°C	736 mW	598 mW	N/A
PW	675 mW	5.4 mW/°C	432 mW	351 mW	N/A

### recommended operating conditions

	TLC3704C			UNIT
	MIN	NOM	MAX	
Supply voltage, $V_{DD}$	3	5	16	V
Common-mode input voltage, $V_{IC}$	-0.2		$V_{DD} - 1.5$	V
High-level output current, $I_{OH}$			-20	mA
Low-level output current, $I_{OL}$			20	mA
Operating free-air temperature, $T_A$	0		70	°C

### electrical characteristics at specified operating free-air temperature, $V_{DD} = 5\text{ V}$ (unless otherwise noted)

PARAMETER		TEST CONDITIONS†	$T_A$	TLC3704C			UNIT
				MIN	TYP	MAX	
$V_{IO}$	Input offset voltage	$V_{DD} = 5\text{ V to }10\text{ V}$ , $V_{IC} = V_{ICRmin}$ , See Note 3	25°C		1.2	5	mV
			0°C to 70°C			6.5	
$I_{IO}$	Input offset current	$V_{IC} = 2.5\text{ V}$	25°C		1		pA
			70°C			0.3	nA
$I_{IB}$	Input bias current	$V_{IC} = 2.5\text{ V}$	25°C		5		pA
			70°C			0.6	nA
$V_{ICR}$	Common-mode input voltage range		25°C	0 to	$V_{DD} - 1$		V
			0°C to 70°C	0 to	$V_{DD} - 1.5$		
CMRR	Common-mode rejection ratio	$V_{IC} = V_{ICRmin}$	25°C		84		dB
			70°C		84		
			0°C		84		
$k_{SVR}$	Supply-voltage rejection ratio	$V_{DD} = 5\text{ V to }10\text{ V}$	25°C		85		dB
			70°C		85		
			0°C		85		
$V_{OH}$	High-level output voltage	$V_{ID} = 1\text{ V}$ , $I_{OH} = -4\text{ mA}$	25°C	4.5	4.7		V
			70°C	4.3			
$V_{OL}$	Low-level output voltage	$V_{ID} = -1\text{ V}$ , $I_{OH} = 4\text{ mA}$	25°C		210	300	mV
			70°C			375	
$I_{DD}$	Supply current (all four comparators)	Outputs low, No load	25°C		35	80	µA
			0°C to 70°C			100	

† All characteristics are measured with zero common-mode voltage unless otherwise noted.

NOTE 3: The offset voltage limits given are the maximum values required to drive the output up to 4.5 V or down to 0.3 V.

# TLC3704, TLC3704Q

## QUAD MICROPOWER LinCMOS™ VOLTAGE COMPARATORS

SLCS117B – NOVEMBER 1986 – REVISED JANUARY 2002

### recommended operating conditions

	TLC3704I			UNIT
	MIN	NOM	MAX	
Supply voltage, $V_{DD}$	3	5	16	V
Common-mode input voltage, $V_{IC}$	-0.2		$V_{DD} - 1.5$	V
High-level output current, $I_{OH}$			-20	mA
Low-level output current, $I_{OL}$			20	mA
Operating free-air temperature, $T_A$	-40		85	°C

### electrical characteristics at specified operating free-air temperature, $V_{DD} = 5\text{ V}$ , $V_{IC} = 0$ (unless otherwise noted)

PARAMETER	TEST CONDITIONS	$T_A$	TLC3704I			UNIT
			MIN	TYP	MAX	
$V_{IO}$ Input offset voltage	$V_{DD} = 5\text{ V to } 10\text{ V}$ , $V_{IC} = V_{ICRmin}$ , See Note 3	25°C		1.2	5	mV
		-40°C to 85°C			7	
$I_{IO}$ Input offset current	$V_{IC} = 2.5\text{ V}$	25°C		1		pA
		85°C			1	nA
$I_{IB}$ Input bias current	$V_{IC} = 2.5\text{ V}$	25°C		5		pA
		85°C			2	nA
$V_{ICR}$ Common-mode input voltage range		25°C		0 to $V_{DD} - 1$		V
		-40°C to 85°C		0 to $V_{DD} - 1.5$		
CMRR Common-mode rejection ratio	$V_{IC} = V_{ICRmin}$	25°C		84		dB
		85°C		84		
		-40°C		83		
$k_{SVR}$ Supply-voltage rejection ratio	$V_{DD} = 5\text{ V to } 10\text{ V}$	25°C		85		dB
		85°C		85		
		-40°C		83		
$V_{OH}$ High-level output voltage	$V_{ID} = 1\text{ V}$ , $I_{OH} = -4\text{ mA}$	25°C	4.5	4.7		V
		85°C	4.3			
$V_{OL}$ Low-level output voltage	$V_{ID} = -1\text{ V}$ , $I_{OH} = 4\text{ mA}$	25°C		210	300	mV
		85°C			400	
$I_{DD}$ Supply current (all four comparators)	Outputs low, No load	25°C		35	80	μA
		-40°C to 85°C			125	

NOTE 3: The offset voltage limits given are the maximum values required to drive the output up to 4.5 V or down to 0.3 V.

# TLC3704, TLC3704Q

## QUAD MICROPOWER LinCMOS™ VOLTAGE COMPARATORS

SLCS117B – NOVEMBER 1986 – REVISED JANUARY 2002

### recommended operating conditions

	TLC3704M			UNIT
	MIN	NOM	MAX	
Supply voltage, $V_{DD}$	4	5	16	V
Common-mode input voltage, $V_{IC}$	0	$V_{DD} - 1.5$		V
High-level output current, $I_{OH}$	– 20			mA
Low-level output current, $I_{OL}$	20			mA
Operating free-air temperature, $T_A$	– 55	125		°C

### electrical characteristics at specified operating free-air temperature, $V_{DD} = 5$ V, $V_{IC} = 0$ (unless otherwise noted)

PARAMETER	TEST CONDITIONS	$T_A$	TLC3704M			UNIT
			MIN	TYP	MAX	
$V_{IO}$ Input offset voltage	$V_{DD} = 5$ V to 10 V, $V_{IC} = V_{ICRmin}$ , See Note 3	25°C	1.2		5	mV
		–55°C to 125°C			10	
$I_{IO}$ Input offset current	$V_{IC} = 2.5$ V	25°C	1			pA
		125°C			15	nA
$I_{IB}$ Input bias current	$V_{IC} = 2.5$ V	25°C	5			pA
		125°C			30	nA
$V_{ICR}$ Common-mode input voltage range		25°C	0 to $V_{DD} - 1$			V
		–55°C to 125°C	0 to $V_{DD} - 1.5$			
CMRR Common-mode rejection ratio	$V_{IC} = V_{ICRmin}$	25°C	84			dB
		125°C	83			
		–55°C	82			
$k_{SVR}$ Supply-voltage rejection ratio	$V_{DD} = 5$ V to 10 V	25°C	85			dB
		125°C	85			
		–55°C	82			
$V_{OH}$ High-level output voltage	$V_{ID} = 1$ V, $I_{OH} = -4$ mA	25°C	4.5	4.7		V
		125°C	4.2			
$V_{OL}$ Low-level output voltage	$V_{ID} = -1$ V, $I_{OH} = 4$ mA	25°C	210		300	mV
		125°C			500	
$I_{DD}$ Supply current (all four comparators)	Outputs low, No load	25°C	35		80	μA
		–55°C to 125°C			175	

NOTE 3: The offset voltage limits given are the maximum values required to drive the output up to 4.5 V or down to 0.3 V.

# TLC3704, TLC3704Q

## QUAD MICROPOWER LinCMOS™ VOLTAGE COMPARATORS

SLCS117B – NOVEMBER 1986 – REVISED JANUARY 2002

### recommended operating conditions

	TLC3704Q			UNIT
	MIN	NOM	MAX	
Supply voltage, $V_{DD}$	3	5	16	V
Common-mode input voltage, $V_{IC}$	-0.2		$V_{DD} - 1.5$	V
High-level output current, $I_{OH}$			-20	mA
Low-level output current, $I_{OL}$			20	mA
Operating free-air temperature, $T_A$	-40		125	°C

### electrical characteristics at specified operating free-air temperature, $V_{DD} = 5\text{ V}$ , $V_{IC} = 0$ (unless otherwise noted)

PARAMETER	TEST CONDITIONS	$T_A$	TLC3704Q			UNIT
			MIN	TYP	MAX	
$V_{IO}$ Input offset voltage	$V_{DD} = 5\text{ V to } 10\text{ V}$ , $V_{IC} = V_{ICRmin}$ , See Note 3	25°C		1.2	5	mV
		-40°C to 125°C			7	
$I_{IO}$ Input offset current	$V_{IC} = 2.5\text{ V}$	25°C		1		pA
		125°C			15	nA
$I_{IB}$ Input bias current	$V_{IC} = 2.5\text{ V}$	25°C		5		pA
		125°C			30	nA
$V_{ICR}$ Common-mode input voltage range		25°C	0 to $V_{DD} - 1$			V
		-40°C to 125°C	0 to $V_{DD} - 1.5$			
CMRR Common-mode rejection ratio	$V_{IC} = V_{ICRmin}$	25°C	84			dB
		125°C	83			
		-40°C	83			
$k_{SVR}$ Supply-voltage rejection ratio	$V_{DD} = 5\text{ V to } 10\text{ V}$	25°C	85			dB
		125°C	85			
		-40°C	83			
$V_{OH}$ High-level output voltage	$V_{ID} = 1\text{ V}$ , $I_{OH} = -4\text{ mA}$	25°C	4.5	4.7		V
		125°C	4.2			
$V_{OL}$ Low-level output voltage	$V_{ID} = -1\text{ V}$ , $I_{OH} = 4\text{ mA}$	25°C		210	300	mV
		125°C		500		
$I_{DD}$ Supply current (all four comparators)	Outputs low, No load	25°C		35	80	μA
		-40°C to 125°C		175		

NOTE 3: The offset voltage limits given are the maximum values required to drive the output up to 4.5 V or down to 0.3 V.

# TLC3704, TLC3704Q

## QUAD MICROPOWER LinCMOS™ VOLTAGE COMPARATORS

SLCS117B – NOVEMBER 1986 – REVISED JANUARY 2002

switching characteristics,  $V_{DD} = 5\text{ V}$ ,  $T_A = 25^\circ\text{C}$

PARAMETER	TEST CONDITIONS	TLC3704C, TLC3704I TLC3704M, TLC3704Q			UNIT
		MIN	TYP	MAX	
t <sub>PLH</sub> Propagation delay time, low-to-high-level output†	f = 10 kHz, C <sub>L</sub> = 50 pF	Overdrive = 2 mV	4.5		μs
		Overdrive = 5 mV	2.7		
		Overdrive = 10 mV	1.9		
		Overdrive = 20 mV	1.4		
		Overdrive = 40 mV	1.1		
	V <sub>I</sub> = 1.4-V step at IN+	1.1			
t <sub>PHL</sub> Propagation delay time, high-to-low-level output†	f = 10 kHz, C <sub>L</sub> = 50 pF	Overdrive = 2 mV	4		μs
		Overdrive = 5 mV	2.3		
		Overdrive = 10 mV	1.5		
		Overdrive = 20 mV	0.95		
		Overdrive = 40 mV	0.65		
	V <sub>I</sub> = 1.4-V step at IN+	0.15			
t <sub>f</sub> Fall time	f = 10 kHz, C <sub>L</sub> = 50 pF	Overdrive = 50 mV	50		ns
t <sub>r</sub> Rise time	f = 10 kHz, C <sub>L</sub> = 50 pF	Overdrive = 50 mV	125		ns

† Simultaneous switching of inputs causes degradation in output response.

# TLC3704, TLC3704Q QUAD MICROPOWER LinCMOS™ VOLTAGE COMPARATORS

SLCS117B – NOVEMBER 1986 – REVISED JANUARY 2002

## PRINCIPLES OF OPERATION

### LinCMOS process

The LinCMOS process is a linear polysilicon-gate CMOS process. Primarily designed for single-supply applications, LinCMOS products facilitate the design of a wide range of high-performance analog functions from operational amplifiers to complex mixed-mode converters.

This short guide is intended to answer the most frequently asked questions related to the quality and reliability of LinCMOS products. Direct further questions to the nearest TI field sales office.

### electrostatic discharge

CMOS circuits are prone to gate oxide breakdown when exposed to high voltages even if the exposure is only for very short periods of time. Electrostatic discharge (ESD) is one of the most common causes of damage to CMOS devices. It can occur when a device is handled without proper consideration for environmental electrostatic charges, e.g., during board assembly. If a circuit in which one amplifier from a dual op amp is being used and the unused pins are left open, high voltages tends to develop. If there is no provision for ESD protection, these voltages may eventually punch through the gate oxide and cause the device to fail. To prevent voltage buildup, each pin is protected by internal circuitry.

Standard ESD-protection circuits safely shunt the ESD current by providing a mechanism whereby one or more transistors break down at voltages higher than the normal operating voltages but lower than the breakdown voltage of the input gate. This type of protection scheme is limited by leakage currents which flow through the shunting transistors during normal operation after an ESD voltage has occurred. Although these currents are small, on the order of tens of nanoamps, CMOS amplifiers are often specified to draw input currents as low as tens of picoamps.

To overcome this limitation, TI design engineers developed the patented ESD-protection circuit shown in Figure 1. This circuit can withstand several successive 2-kV ESD pulses, while reducing or eliminating leakage currents that may be drawn through the input pins. A more detailed discussion of the operation of the TI ESD-protection circuit is presented on the next page.

All input and output pins on LinCMOS and Advanced LinCMOS products have associated ESD-protection circuitry that undergoes qualification testing to withstand 2000 V discharged from a 100-pF capacitor through a 1500-Ω resistor (human body model) and 200 V from a 100-pF capacitor with no current-limiting resistor (charged device model). These tests simulate both operator and machine handling of devices during normal test and assembly operations.

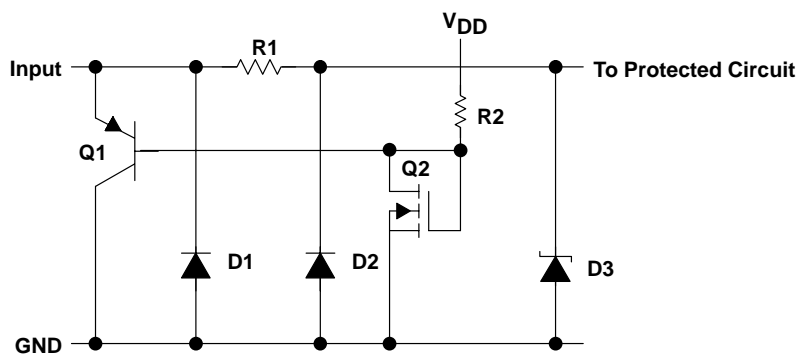


Figure 1. LinCMOS ESD-Protection Schematic



# TLC3704, TLC3704Q QUAD MICROPOWER LinCMOS™ VOLTAGE COMPARATORS

SLCS117B – NOVEMBER 1986 – REVISED JANUARY 2002

## PRINCIPLES OF OPERATION

### input protection circuit operation

Texas Instruments patented protection circuitry allows for both positive- and negative-going ESD transients. These transients are characterized by extremely fast rise times and usually low energies, and can occur both when the device has all pins open and when it is installed in a circuit.

### positive ESD transients

Initial positive charged energy is shunted through Q1 to  $V_{SS}$ . Q1 turns on when the voltage at the input rises above the voltage on the  $V_{DD}$  pin by a value equal to the  $V_{BE}$  of Q1. The base current increases through R2 with input current as Q1 saturates. The base current through R2 forces the voltage at the drain and gate of Q2 to exceed its threshold level ( $V_T \sim 22$  to  $26$  V) and turn Q2 on. The shunted input current through Q1 to  $V_{SS}$  is now shunted through the n-channel enhancement-type MOSFET Q2 to  $V_{SS}$ . If the voltage on the input pin continues to rise, the breakdown voltage of the zener diode D3 is exceeded, and all remaining energy is dissipated in R1 and D3. The breakdown voltage of D3 is designed to be 24 to 27 V, which is well below the gate-oxide voltage of the circuit to be protected.

### negative ESD transients

The negative charged ESD transients are shunted directly through D1. Additional energy is dissipated in R1 and D2 as D2 becomes forward biased. The voltage seen by the protected circuit is  $-0.3$  V to  $-1$  V (the forward voltage of D1 and D2).

### circuit-design considerations

LinCMOS products are being used in actual circuit environments that have input voltages that exceed the recommended common-mode input voltage range and activate the input protection circuit. Even under normal operation, these conditions occur during circuit power up or power down, and in many cases, when the device is being used for a signal conditioning function. The input voltages can exceed  $V_{ICR}$  and not damage the device only if the inputs are current limited. The recommended current limit shown on most product data sheets is  $\pm 5$  mA. Figures 2 and 3 show typical characteristics for input voltage versus input current.

Normal operation and correct output state can be expected even when the input voltage exceeds the positive supply voltage. Again, the input current should be externally limited even though internal positive current limiting is achieved in the input protection circuit by the action of Q1. When Q1 is on, it saturates and limits the current to approximately 5-mA collector current by design. When saturated, Q1 base current increases with input current. This base current is forced into the  $V_{DD}$  pin and into the device  $I_{DD}$  or the  $V_{DD}$  supply through R2 producing the current limiting effects shown in Figure 2. This internal limiting lasts only as long as the input voltage is below the  $V_T$  of Q2.

When the input voltage exceeds the negative supply voltage, normal operation is affected and output voltage states may not be correct. Also, the isolation between channels of multiple devices (duals and quads) can be severely affected. External current limiting must be used since this current is directly shunted by D1 and D2 and no internal limiting is achieved. If normal output voltage states are required, an external input voltage clamp is required (see Figure 4).

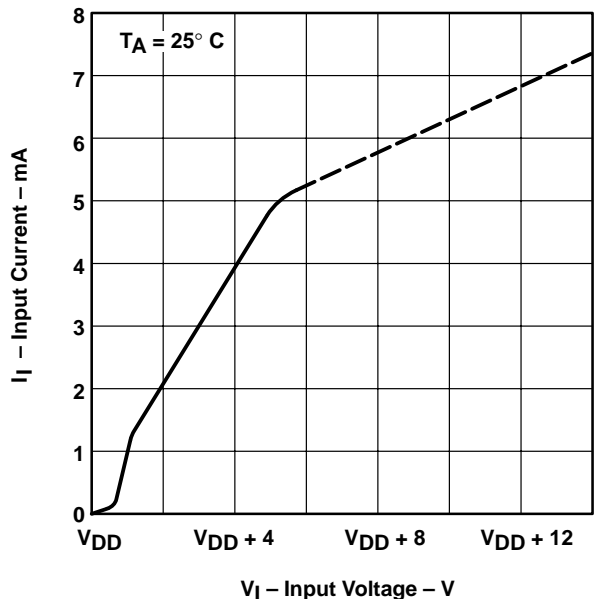
# TLC3704, TLC3704Q QUAD MICROPOWER LinCMOS™ VOLTAGE COMPARATORS

SLCS117B – NOVEMBER 1986 – REVISED JANUARY 2002

## PRINCIPLES OF OPERATION

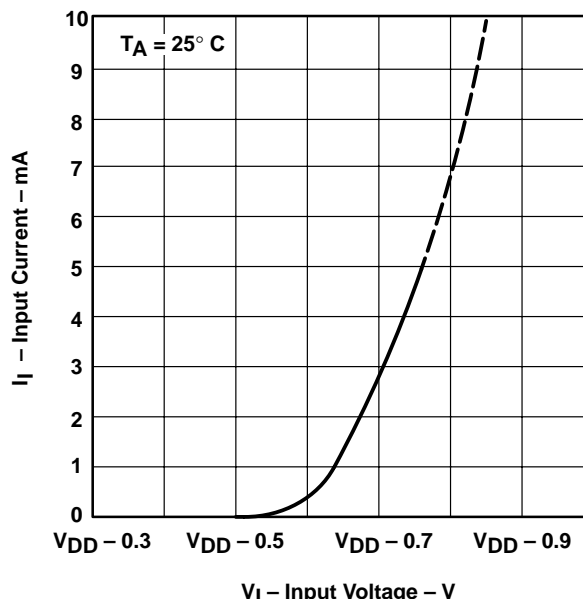
circuit-design considerations (continued)

**INPUT CURRENT  
vs  
INPUT VOLTAGE**

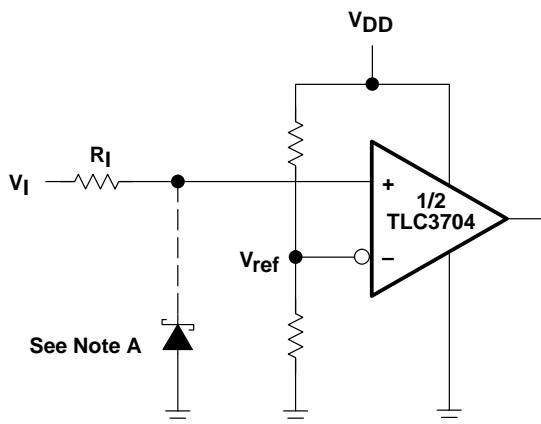


**Figure 2**

**INPUT CURRENT  
vs  
INPUT VOLTAGE**



**Figure 3**



Positive Voltage Input Current Limit :

$$R_I = \frac{V_I - V_{DD} - 0.3 \text{ V}}{5 \text{ mA}}$$

Negative Voltage Input Current Limit :

$$R_I = \frac{-V_I - V_{DD} - (-0.3 \text{ V})}{5 \text{ mA}}$$

NOTE A: If the correct input state is required when the negative input exceeds GND, a Schottky clamp is required.

**Figure 4. Typical Input Current-Limiting Configuration for a LinCMOS Comparator**

# TLC3704, TLC3704Q QUAD MICROPOWER LinCMOS™ VOLTAGE COMPARATORS

SLCS117B – NOVEMBER 1986 – REVISED JANUARY 2002

## PARAMETER MEASUREMENT INFORMATION

The TLC3704 contains a digital output stage which, if held in the linear region of the transfer curve, can cause damage to the device. Conventional operational amplifier/comparator testing incorporates the use of a servo loop which is designed to force the device output to a level within this linear region. Since the servo-loop method of testing cannot be used, we offer the following alternatives for measuring parameters such as input offset voltage, common-mode rejection, etc.

To verify that the input offset voltage falls within the limits specified, the limit value is applied to the input as shown in Figure 5(a). With the noninverting input positive with respect to the inverting input, the output should be high. With the input polarity reversed, the output should be low.

A similar test can be made to verify the input offset voltage at the common-mode extremes. The supply voltages can be slewed as shown in Figure 5(b) for the  $V_{ICR}$  test, rather than changing the input voltages, to provide greater accuracy.

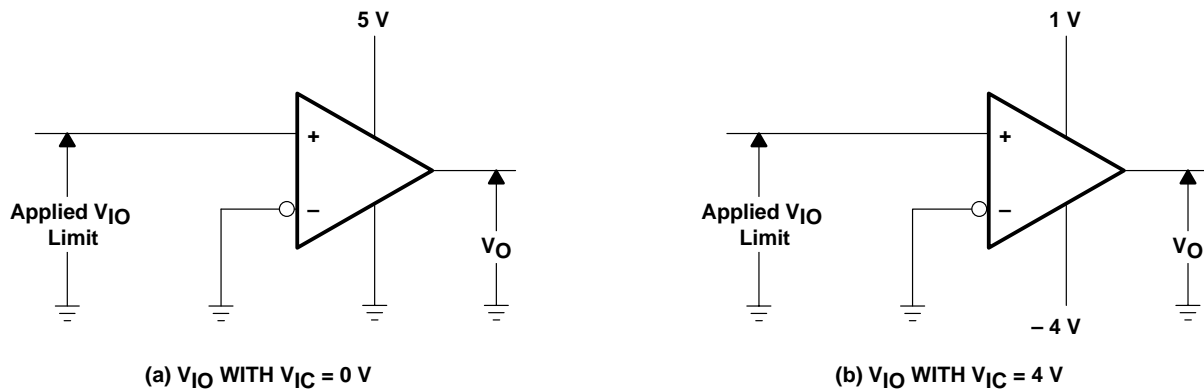


Figure 5. Method for Verifying That Input Offset Voltage Is Within Specified Limits

A close approximation of the input offset voltage can be obtained by using a binary search method to vary the differential input voltage while monitoring the output state. When the applied input voltage differential is equal, but opposite in polarity, to the input offset voltage, the output changes states.

Figure 6 illustrates a practical circuit for direct dc measurement of input offset voltage that does not bias the comparator in the linear region. The circuit consists of a switching mode servo loop in which IC1a generates a triangular waveform of approximately 20-mV amplitude. IC1b acts as a buffer, with C2 and R4 removing any residual d.c. offset. The signal is then applied to the inverting input of the comparator under test, while the noninverting input is driven by the output of the integrator formed by IC1c through the voltage divider formed by R8 and R9. The loop reaches a stable operating point when the output of the comparator under test has a duty cycle of exactly 50%, which can only occur when the incoming triangle wave is sliced symmetrically or when the voltage at the noninverting input exactly equals the input offset voltage.

Voltage divider R8 and R9 provides an increase in the input offset voltage by a factor of 100 to make measurement easier. The values of R5, R7, R8, and R9 can significantly influence the accuracy of the reading; therefore, it is suggested that their tolerance level be one percent or lower.

Measuring the extremely low values of input current requires isolation from all other sources of leakage current and compensation for the leakage of the test socket and board. With a good picoammeter, the socket and board leakage can be measured with no device in the socket. Subsequently, this open socket leakage value can be subtracted from the measurement obtained with a device in the socket to obtain the actual input current of the device.

# TLC3704, TLC3704Q QUAD MICROPOWER LinCMOS™ VOLTAGE COMPARATORS

SLCS117B – NOVEMBER 1986 – REVISED JANUARY 2002

## PARAMETER MEASUREMENT INFORMATION

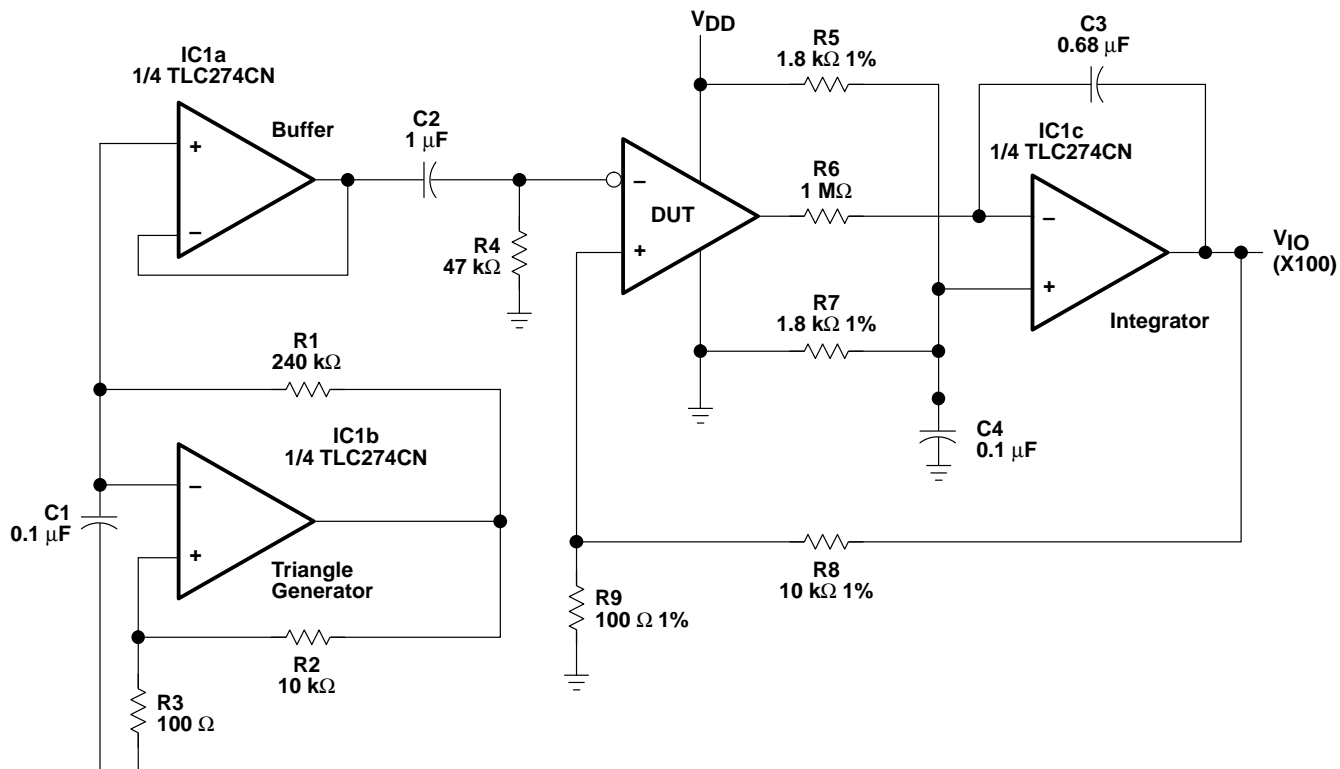


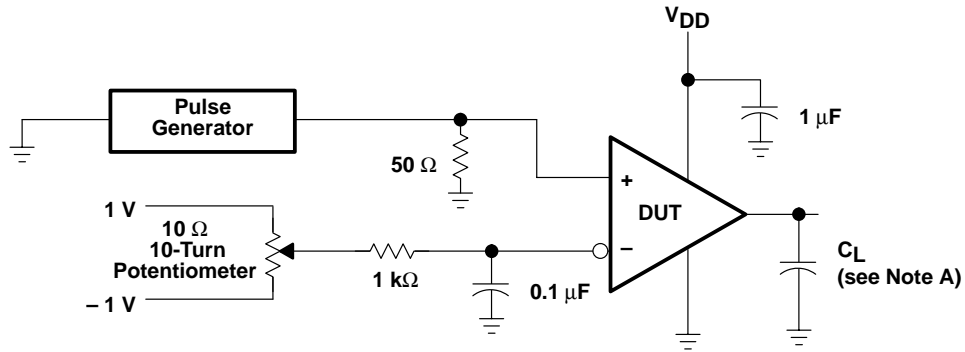
Figure 6. Circuit for Input Offset Voltage Measurement

Response time is defined as the interval between the application of an input step function and the instant when the output reaches 50% of its maximum value. Response time for the low-to-high-level output is measured from the leading edge of the input pulse, while response time for the high-to-low-level output is measured from the trailing edge of the input pulse. Response time measurement at low input signal levels can be greatly affected by the input offset voltage. The offset voltage should be balanced by the adjustment at the inverting input as shown in Figure 7, so that the circuit is just at the transition point. A low signal, for example 105-mV or 5-mV overdrive, causes the output to change state.

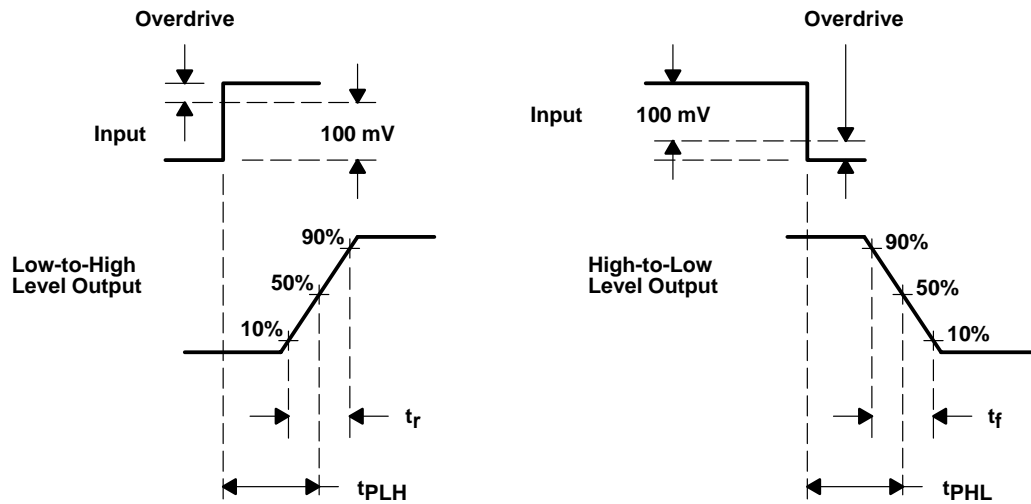
# TLC3704, TLC3704Q QUAD MICROPOWER LinCMOS™ VOLTAGE COMPARATORS

SLCS117B – NOVEMBER 1986 – REVISED JANUARY 2002

## PARAMETER MEASUREMENT INFORMATION



TEST CIRCUIT



VOLTAGE WAVEFORMS

NOTE A:  $C_L$  includes probe and jig capacitance.

Figure 7. Response, Rise, and Fall Times Circuit and Voltage Waveforms

# TLC3704, TLC3704Q QUAD MICROPOWER LinCMOS™ VOLTAGE COMPARATORS

SLCS117B – NOVEMBER 1986 – REVISED JANUARY 2002

## TYPICAL CHARACTERISTICS

Table of Graphs

			FIGURE
$V_{IO}$	Input offset voltage	Distribution	8
$I_{IB}$	Input bias current	vs Free-air temperature	9
CMRR	Common-mode rejection ratio	vs Free-air temperature	10
$k_{SVR}$	Supply-voltage rejection ratio	vs Free-air temperature	11
$V_{OH}$	High-level output current	vs Free-air temperature vs High-level output current	12 13
$V_{OL}$	Low-level output voltage	vs Low-level output current vs Free-air temperature	14 15
$t_t$	Output transition time	vs Load capacitance	16
	Supply current response to an output voltage transition		17
	Low-to-high-level output response for various input overdrives		18
	High-to-low-level output response for various input overdrives		19
$t_{PLH}$	Low-to-high-level output response time	vs Supply voltage	20
$t_{PHL}$	High-to-low-level output response time	vs Supply voltage	21
$I_{DD}$	Supply current	vs Frequency vs Supply voltage vs Free-air temperature	22 23 24

DISTRIBUTION OF INPUT  
OFFSET VOLTAGE†

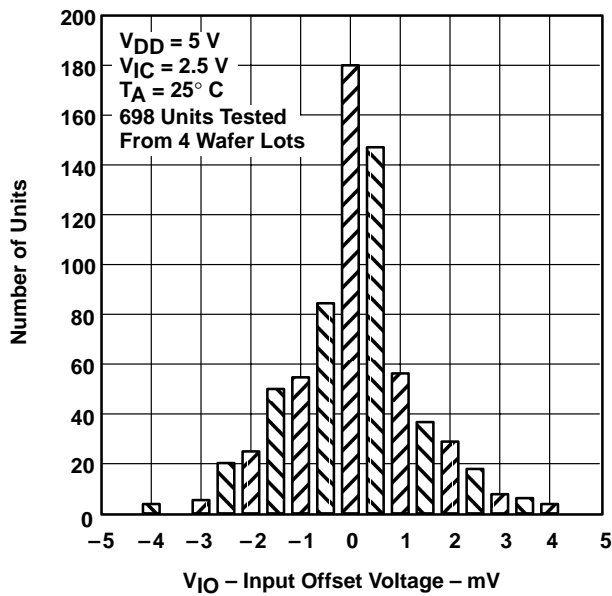


Figure 8

INPUT BIAS CURRENT  
vs  
FREE-AIR TEMPERATURE†

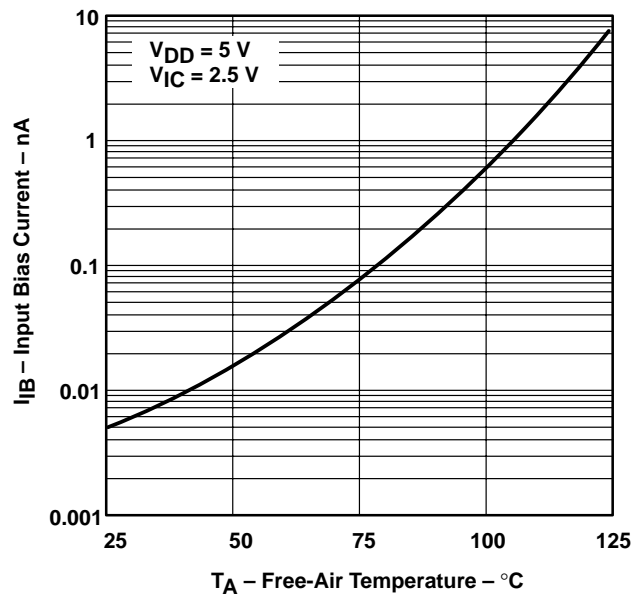


Figure 9

† Data at high and low temperatures are applicable only within the rated operating free-air temperature ranges of the various devices.

# TLC3704, TLC3704Q

## QUAD MICROPOWER LinCMOS™ VOLTAGE COMPARATORS

SLCS117B – NOVEMBER 1986 – REVISED JANUARY 2002

### TYPICAL CHARACTERISTICS†

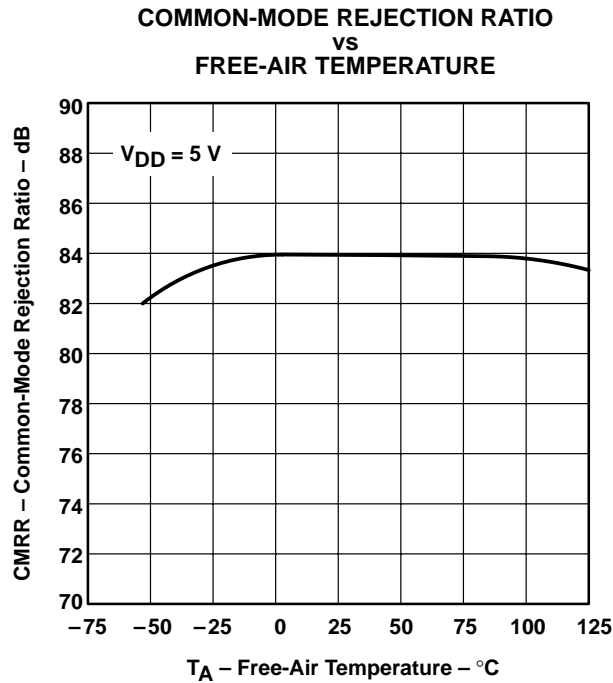


Figure 10

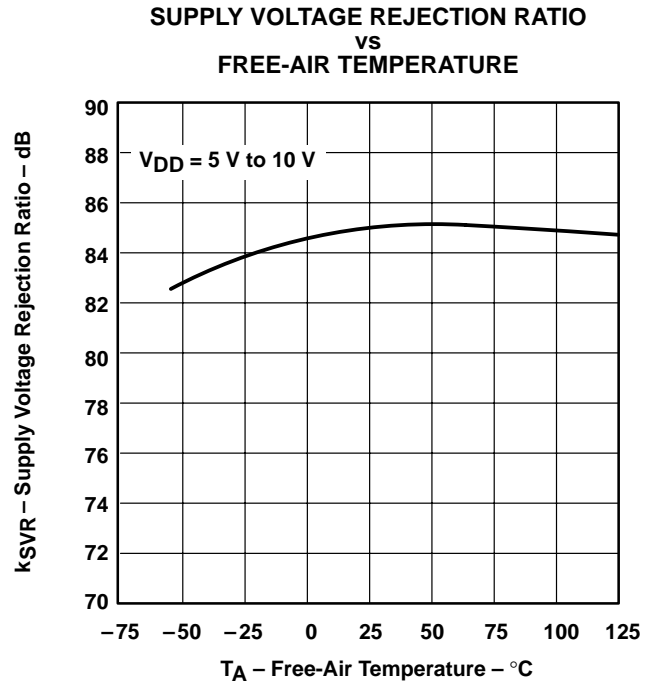


Figure 11

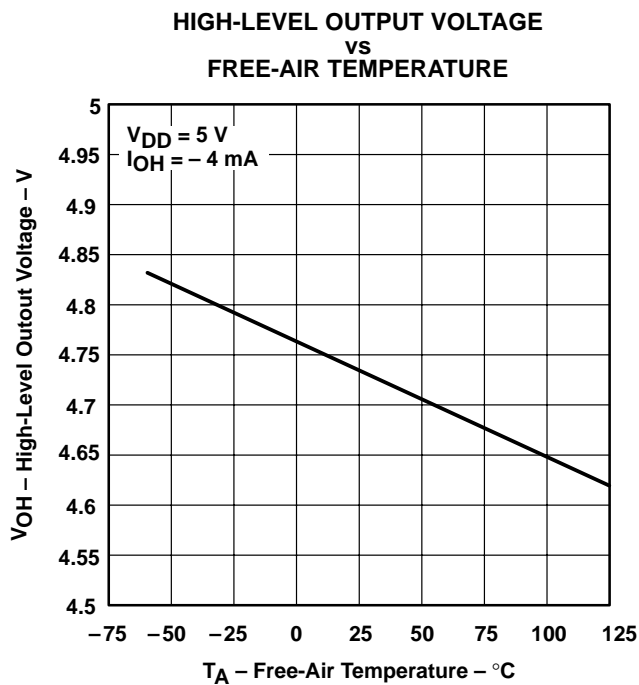


Figure 12

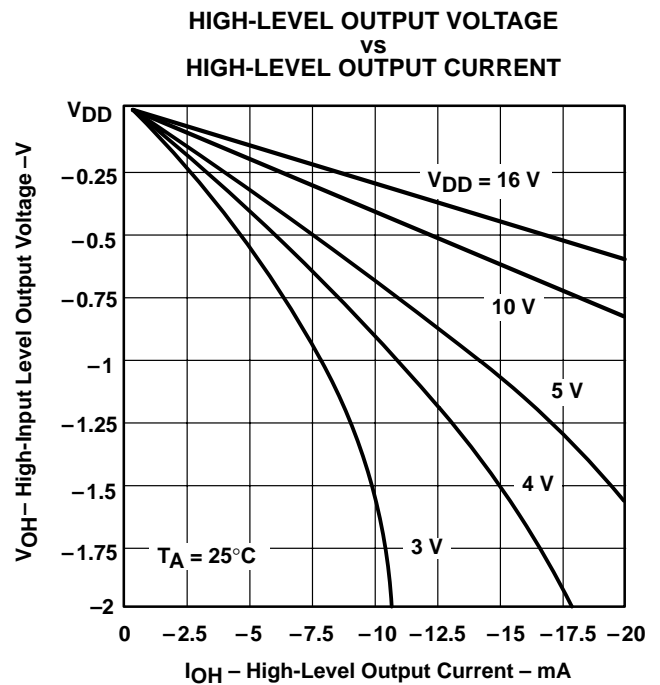


Figure 13

† Data at high and low temperatures are applicable only within the rated operating free-air temperature ranges of the various devices.

# TLC3704, TLC3704Q QUAD MICROPOWER LinCMOS™ VOLTAGE COMPARATORS

SLCS117B – NOVEMBER 1986 – REVISED JANUARY 2002

## TYPICAL CHARACTERISTICS†

LOW-LEVEL OUTPUT VOLTAGE  
vs  
LOW-LEVEL OUTPUT CURRENT

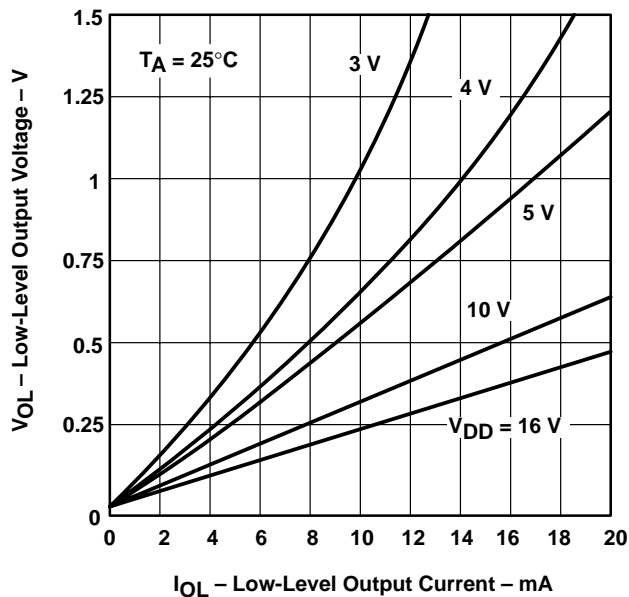


Figure 14

LOW-LEVEL OUTPUT VOLTAGE  
vs  
FREE-AIR TEMPERATURE

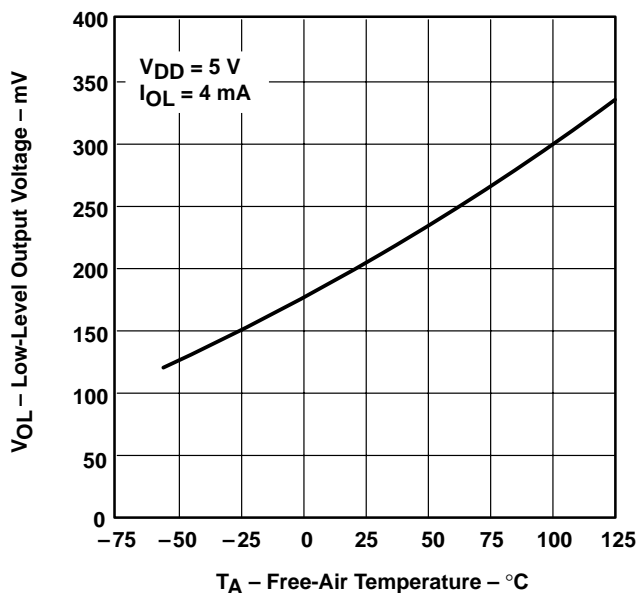


Figure 15

OUTPUT TRANSITION TIME  
vs  
LOAD CAPACITANCE

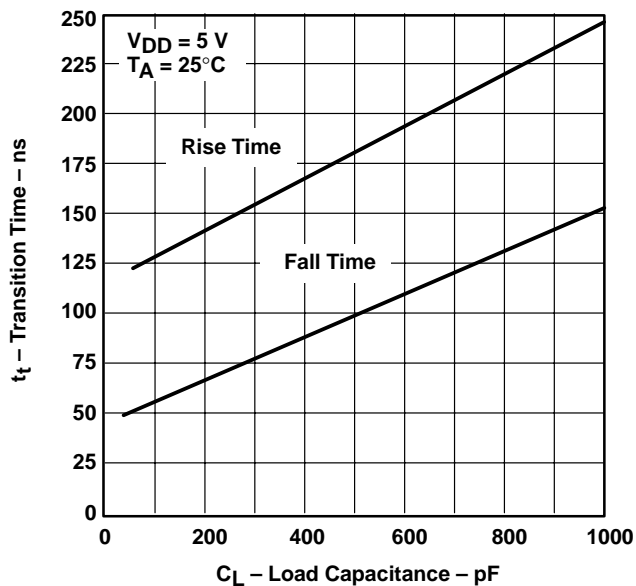


Figure 16

SUPPLY CURRENT RESPONSE  
TO AN OUTPUT VOLTAGE TRANSITION

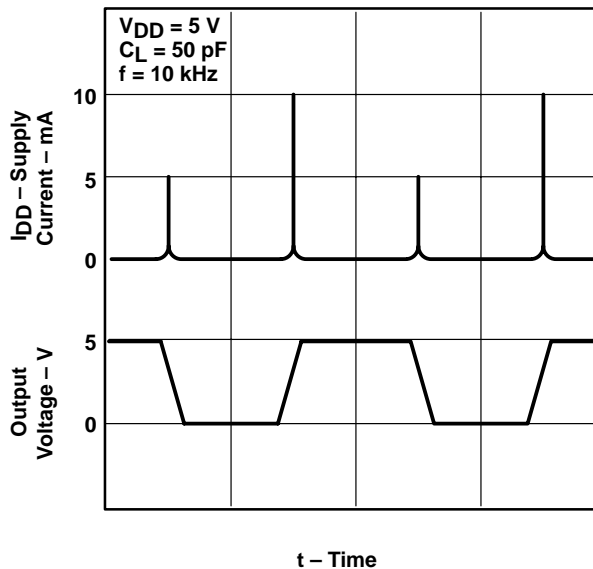


Figure 17

† Data at high and low temperatures are applicable only within the rated operating free-air temperature ranges of the various devices.



# TLC3704, TLC3704Q QUAD MICROPOWER LinCMOS™ VOLTAGE COMPARATORS

SLCS117B – NOVEMBER 1986 – REVISED JANUARY 2002

## TYPICAL CHARACTERISTICS

LOW-TO-HIGH-LEVEL OUTPUT RESPONSE  
FOR VARIOUS INPUT OVERDRIVES

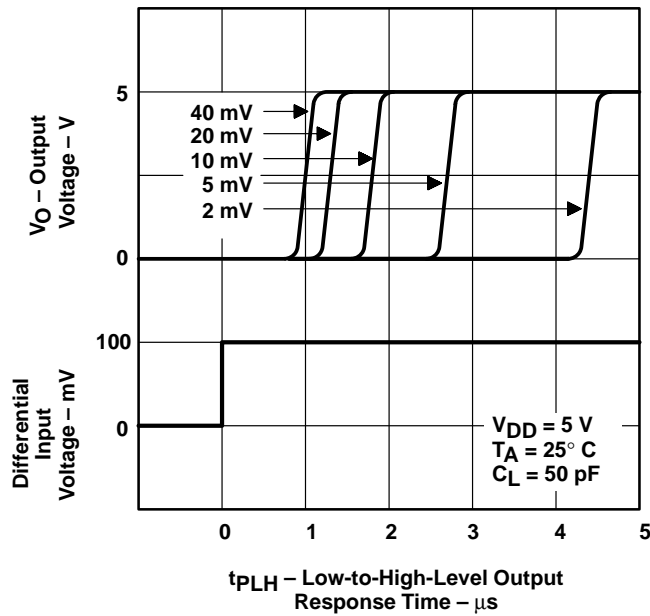


Figure 18

HIGH-TO-LOW-LEVEL OUTPUT RESPONSE  
FOR VARIOUS INPUT OVERDRIVES

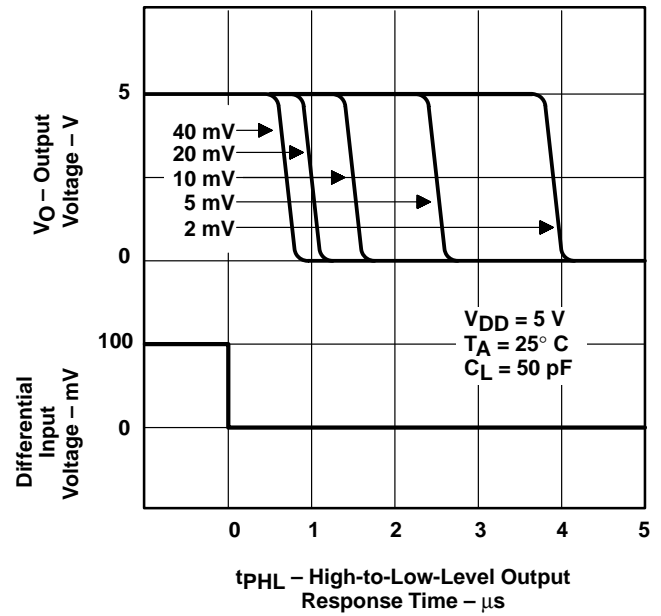


Figure 19

LOW-TO-HIGH-LEVEL  
OUTPUT RESPONSE TIME  
VS  
SUPPLY VOLTAGE

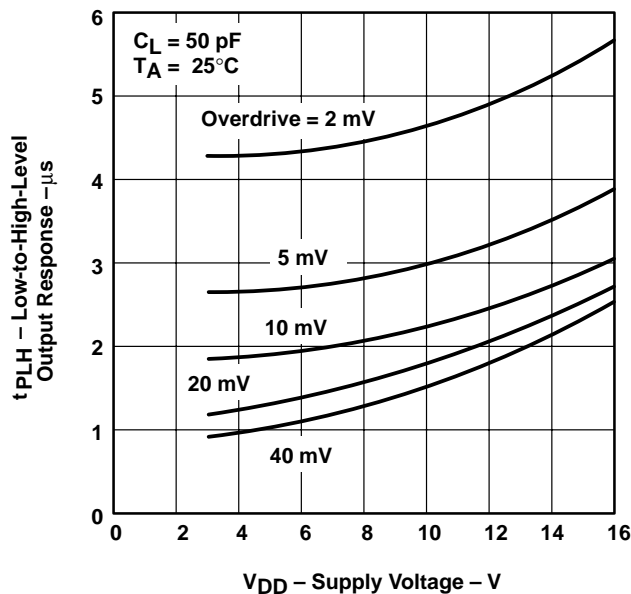


Figure 20

HIGH-TO-LOW-LEVEL  
OUTPUT RESPONSE TIME  
VS  
SUPPLY VOLTAGE

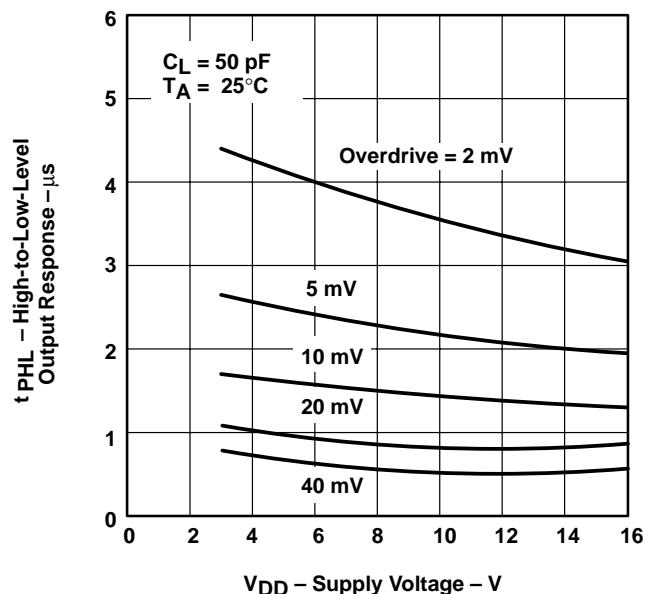


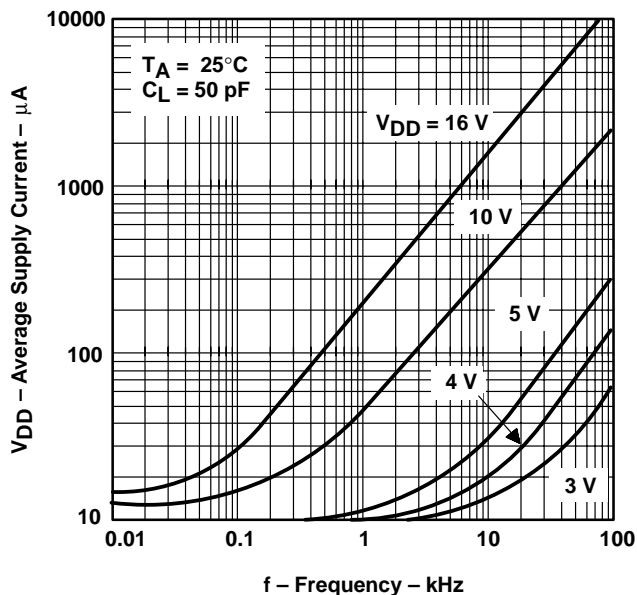
Figure 21

# TLC3704, TLC3704Q QUAD MICROPOWER LinCMOS™ VOLTAGE COMPARATORS

SLCS117B – NOVEMBER 1986 – REVISED JANUARY 2002

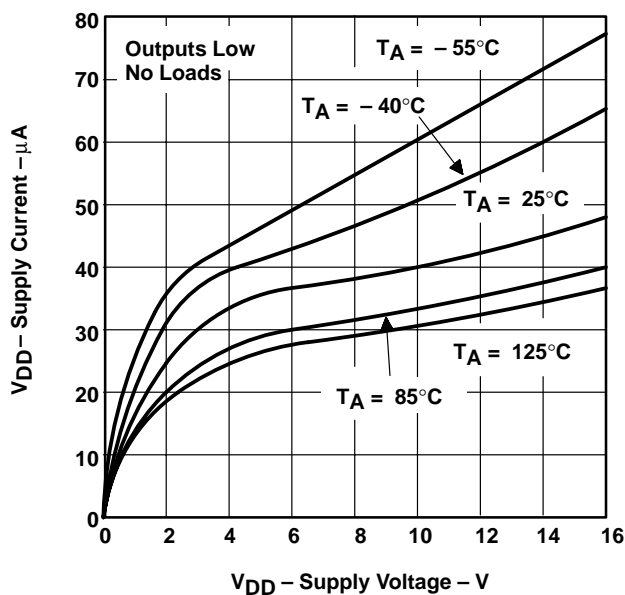
## TYPICAL CHARACTERISTICS†

**AVERAGE SUPPLY CURRENT  
(PER COMPARATOR)  
vs  
FREQUENCY**



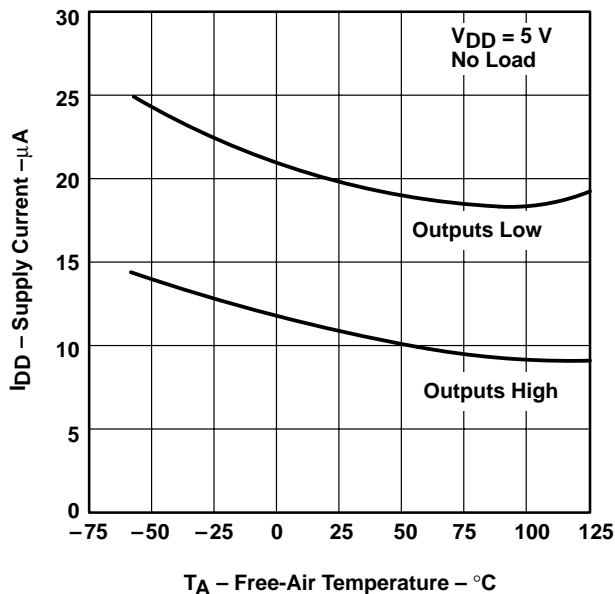
f – Frequency – kHz  
**Figure 22**

**SUPPLY CURRENT  
vs  
SUPPLY VOLTAGE**



$V_{DD}$  – Supply Voltage – V  
**Figure 23**

**SUPPLY CURRENT  
vs  
FREE-AIR TEMPERATURE**



$T_A$  – Free-Air Temperature –  $^\circ\text{C}$   
**Figure 24**

† Data at high and low temperatures are applicable only within the rated operating free-air temperature ranges of the various devices.

# TLC3704, TLC3704Q QUAD MICROPOWER LinCMOS™ VOLTAGE COMPARATORS

SLCS117B – NOVEMBER 1986 – REVISED JANUARY 2002

## APPLICATION INFORMATION

The inputs should always remain within the supply rails in order to avoid forward biasing the diodes in the electrostatic discharge (ESD) protection structure. If either input exceeds this range, the device is not damaged as long as the input is limited to less than 5 mA. To maintain the expected output state, the inputs must remain within the common-mode range. For example, at 25°C with  $V_{DD} = 5$  V, both inputs must remain between  $-0.2$  V and 4 V to ensure proper device operation. To ensure reliable operation, the supply should be decoupled with a capacitor (0.1  $\mu$ F) that is positioned as close to the device as possible.

Output and supply current limitations should be watched carefully since the TLC3704 does not provide current protection. For example, each output can source or sink a maximum of 20 mA; however, the total current to ground can only be an absolute maximum of 60 mA. This prohibits sinking 20 mA from each of the four outputs simultaneously since the total current to ground would be 80 mA.

The TLC3704 has internal ESD-protection circuits that prevents functional failures at voltages up to 2000 V as tested under MIL-STD-883C, Method 3015.2; however, care should be exercised in handling these devices as exposure to ESD may result in the degradation of the device parametric performance.

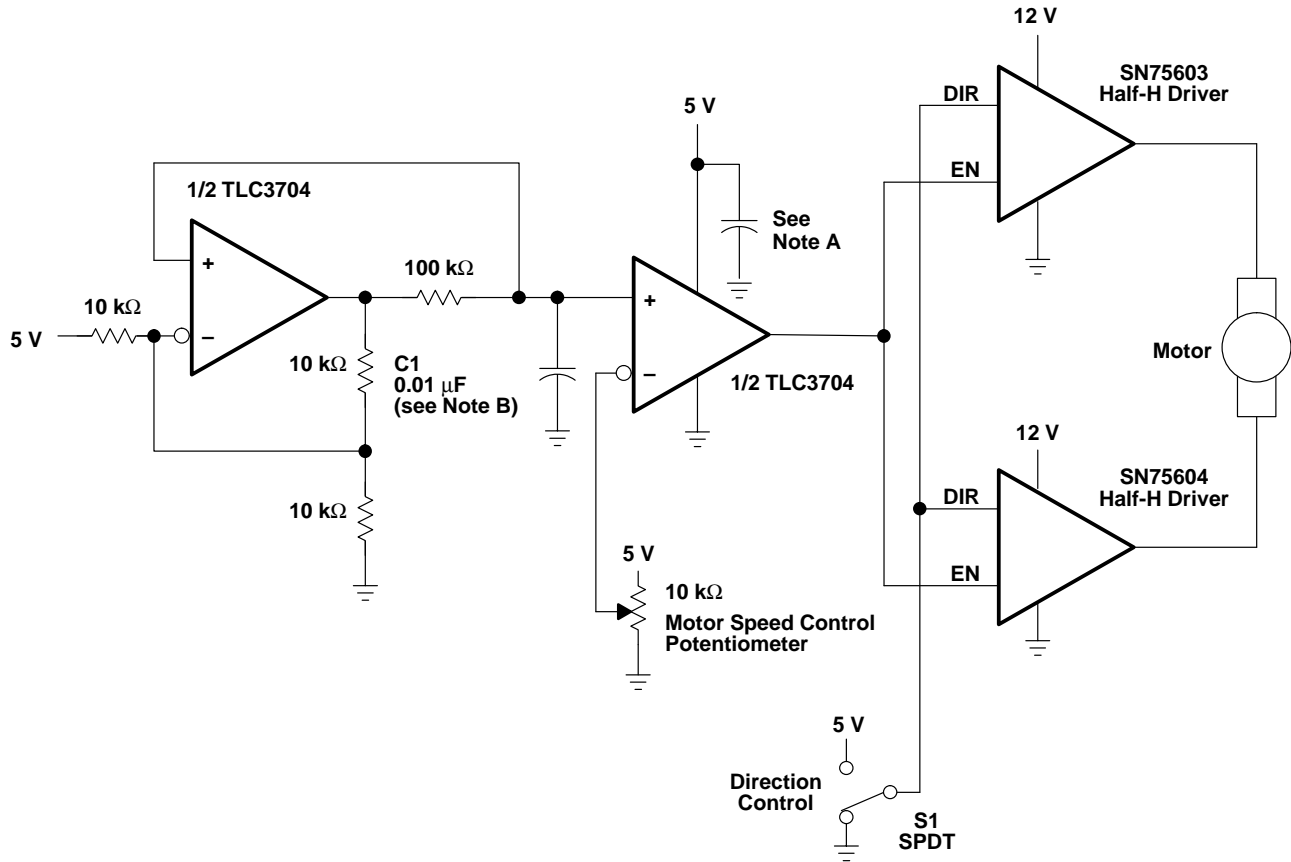
**Table of Applications**

	FIGURE
Pulse-width-modulated motor speed controller	25
Enhanced supply supervisor	26
Two-phase nonoverlapping clock generator	27
Micropower switching regulator	28

# TLC3704, TLC3704Q QUAD MICROPOWER LinCMOS™ VOLTAGE COMPARATORS

SLCS117B – NOVEMBER 1986 – REVISED JANUARY 2002

## APPLICATION INFORMATION



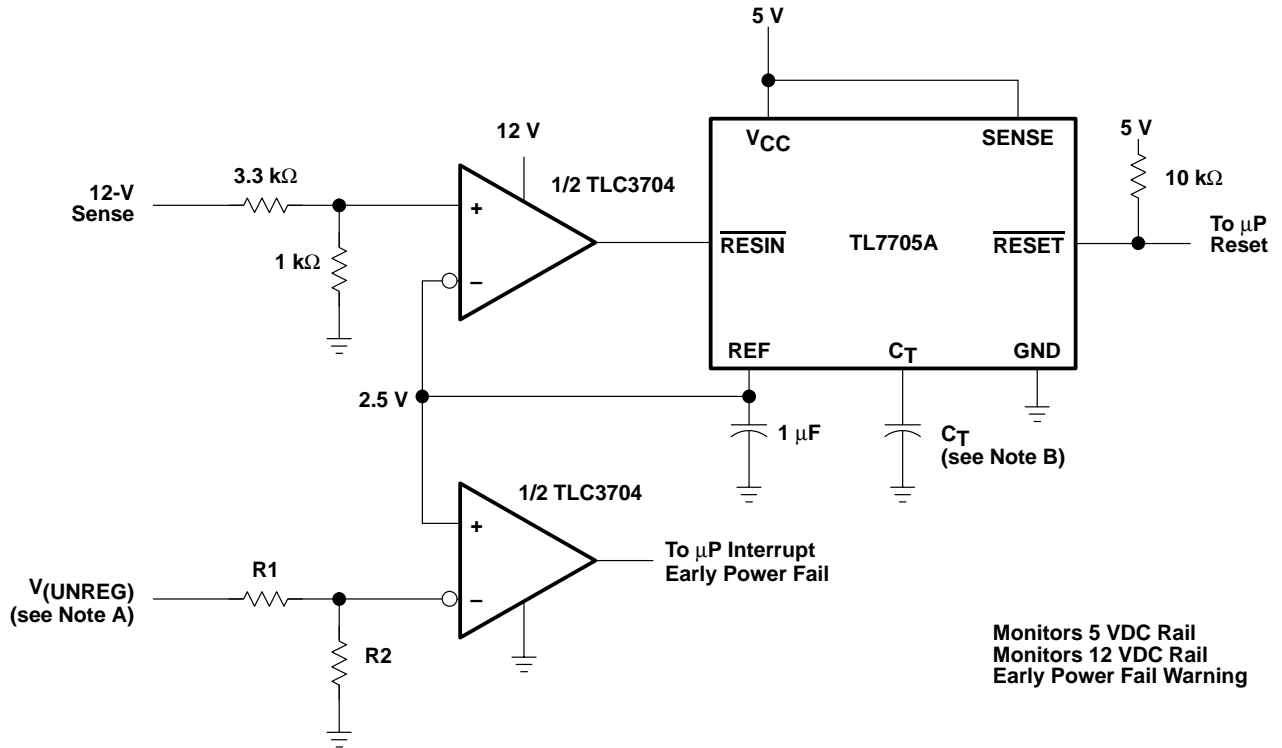
NOTES: A. The recommended minimum capacitance is 10  $\mu$ F to eliminate common ground switching noise.  
B. Adjust C1 for change in oscillator frequency

**Figure 25. Pulse-Width-Modulated Motor Speed Controller**

# TLC3704, TLC3704Q QUAD MICROPOWER LinCMOS™ VOLTAGE COMPARATORS

SLCS117B – NOVEMBER 1986 – REVISED JANUARY 2002

## APPLICATION INFORMATION



Monitors 5 VDC Rail  
Monitors 12 VDC Rail  
Early Power Fail Warning

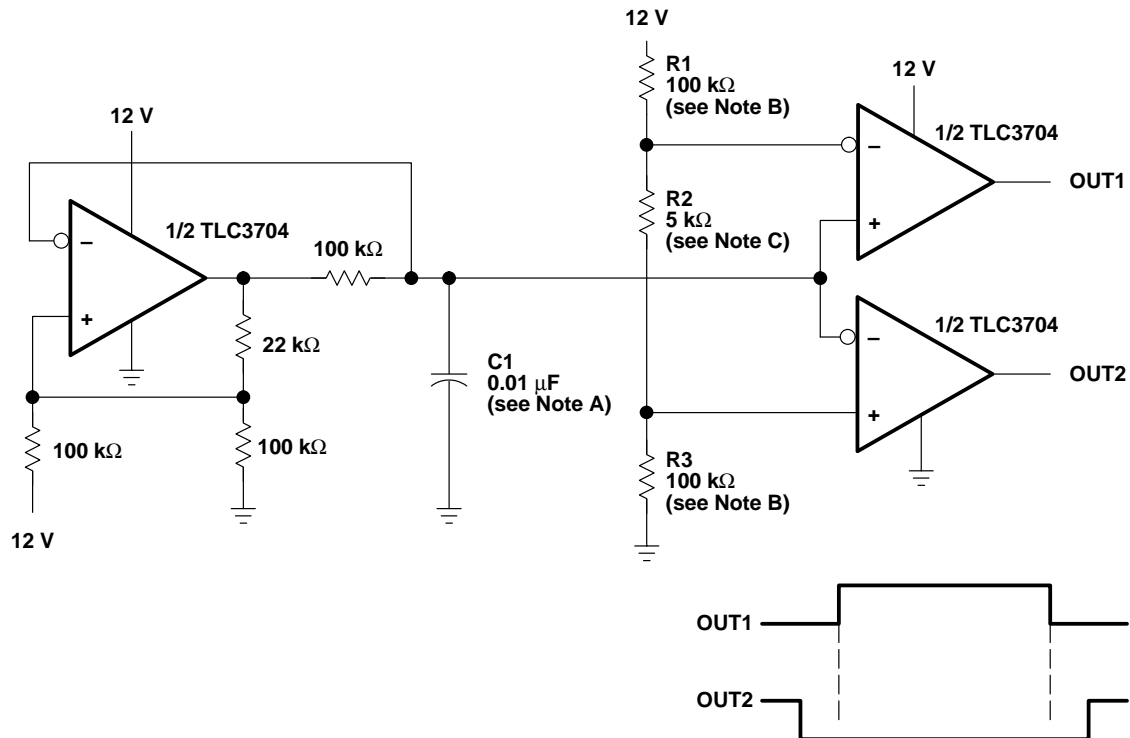
- NOTES: A.  $V_{(UNREG)} = 2.5 \frac{(R1 + R2)}{R2}$   
B. The value of  $C_T$  determines the time delay of reset.

Figure 26. Enhanced Supply Supervisor

# TLC3704, TLC3704Q QUAD MICROPOWER LinCMOS™ VOLTAGE COMPARATORS

SLCS117B – NOVEMBER 1986 – REVISED JANUARY 2002

## APPLICATION INFORMATION



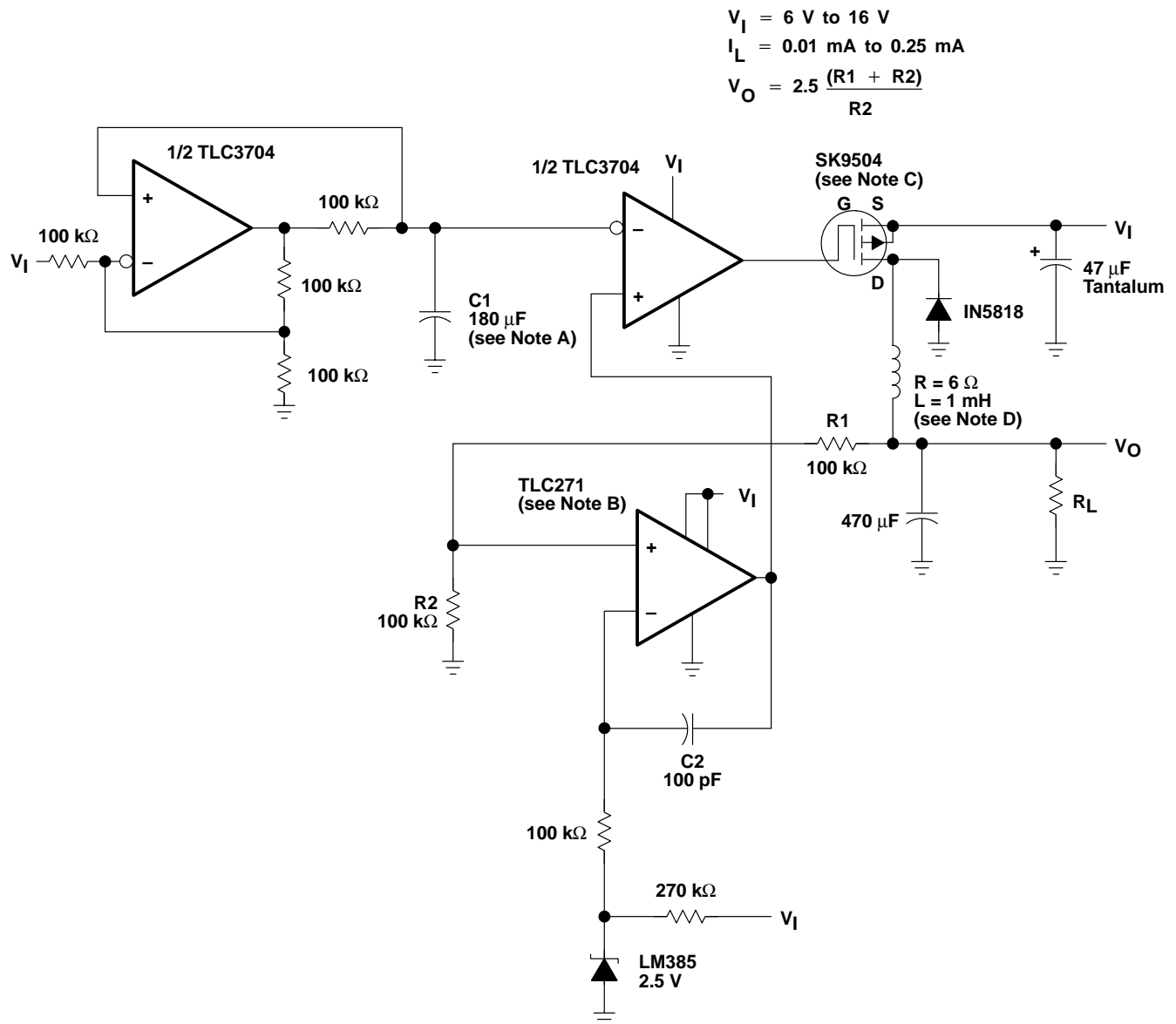
- NOTES: A. Adjust C1 for a change in oscillator frequency where:  
 $1/f = 1.85(100 \text{ k}\Omega)C1$   
 B. Adjust R1 and R3 to change duty cycle  
 C. Adjust R2 to change deadtime

Figure 27. Two-Phase Nonoverlapping Clock Generator

# TLC3704, TLC3704Q QUAD MICROPOWER LinCMOS™ VOLTAGE COMPARATORS

SLCS117B – NOVEMBER 1986 – REVISED JANUARY 2002

## APPLICATION INFORMATION



- NOTES: A. Adjust  $C1$  for a change in oscillator frequency  
 B. TLC271 – Tie pin 8 to pin 7 for low bias operation  
 C. SK9504 –  $V_{DS} = 40\text{ V}$   
 $I_{DS} = 1\text{ A will}$   
 D. To achieve microampere current drive, the inductance of the circuit must be increased.

Figure 28. Micropower Switching Regulator

# TLC3704, TLC3704Q QUAD MICROPOWER LinCMOS™ VOLTAGE COMPARATORS

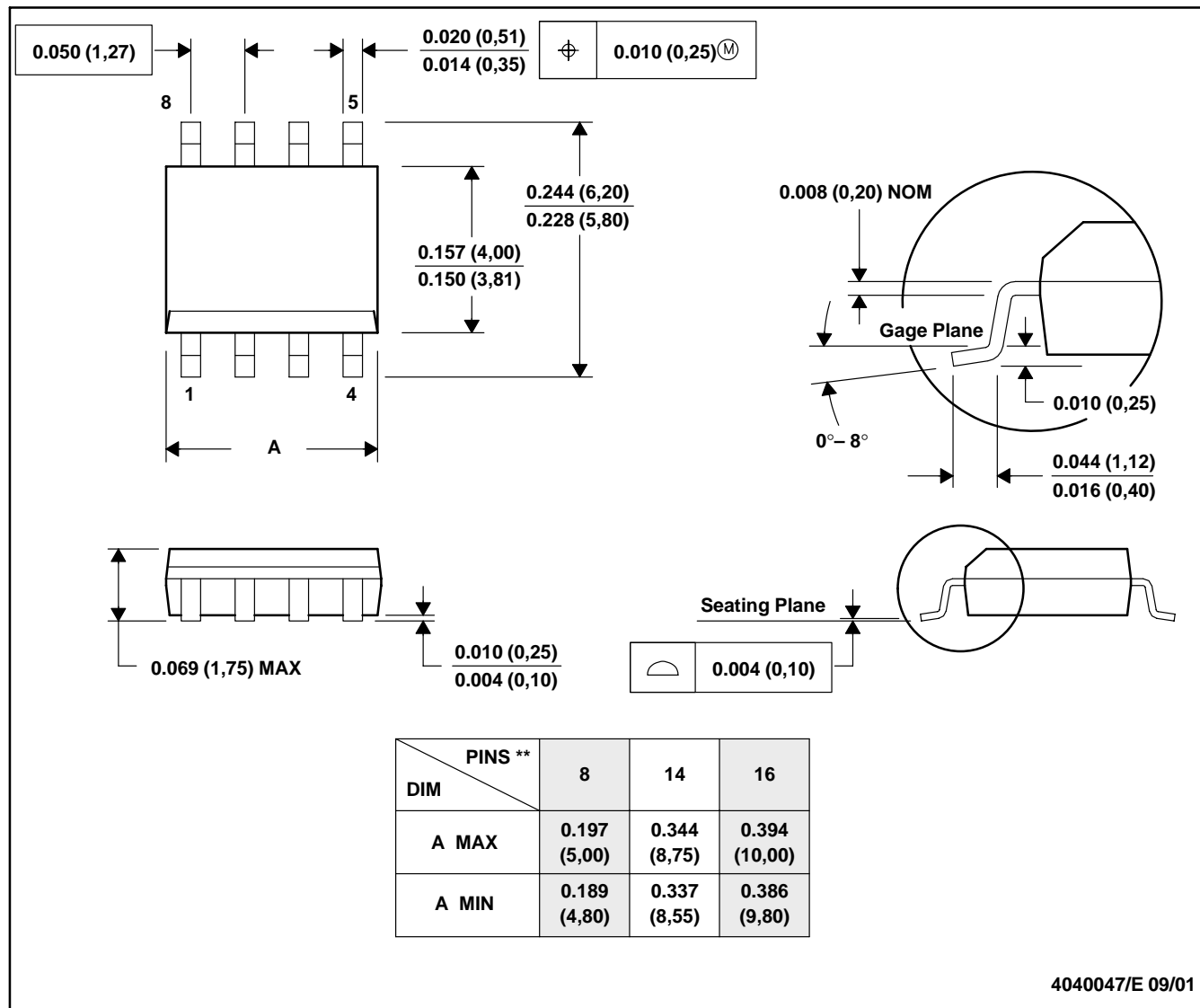
SLCS117B – NOVEMBER 1986 – REVISED JANUARY 2002

## MECHANICAL DATA

D (R-PDSO-G\*\*)

PLASTIC SMALL-OUTLINE PACKAGE

8 PINS SHOWN



- NOTES: A. All linear dimensions are in inches (millimeters).  
 B. This drawing is subject to change without notice.  
 C. Body dimensions do not include mold flash or protrusion, not to exceed 0.006 (0,15).  
 D. Falls within JEDEC MS-012



# TLC3704, TLC3704Q QUAD MICROPOWER LinCMOS™ VOLTAGE COMPARATORS

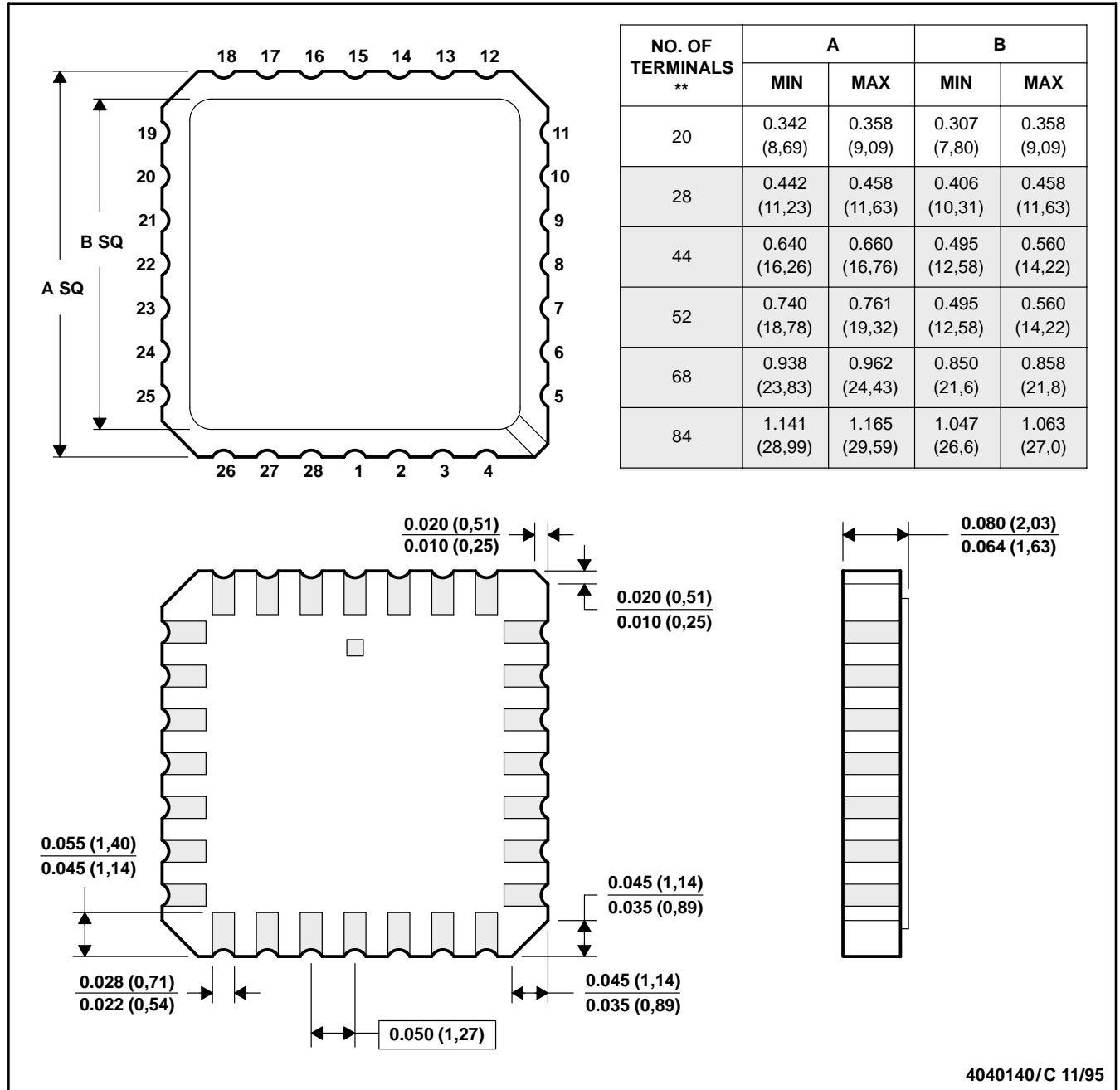
SLCS117B – NOVEMBER 1986 – REVISED JANUARY 2002

## MECHANICAL DATA

**FK (S-CQCC-N\*\*)**

**LEADLESS CERAMIC CHIP CARRIER**

28 TERMINALS SHOWN



- NOTES:
- A. All linear dimensions are in inches (millimeters).
  - B. This drawing is subject to change without notice.
  - C. This package can be hermetically sealed with a metal lid.
  - D. The terminals are gold-plated.
  - E. Falls within JEDEC MS-004

# TLC3704, TLC3704Q QUAD MICROPOWER LinCMOS™ VOLTAGE COMPARATORS

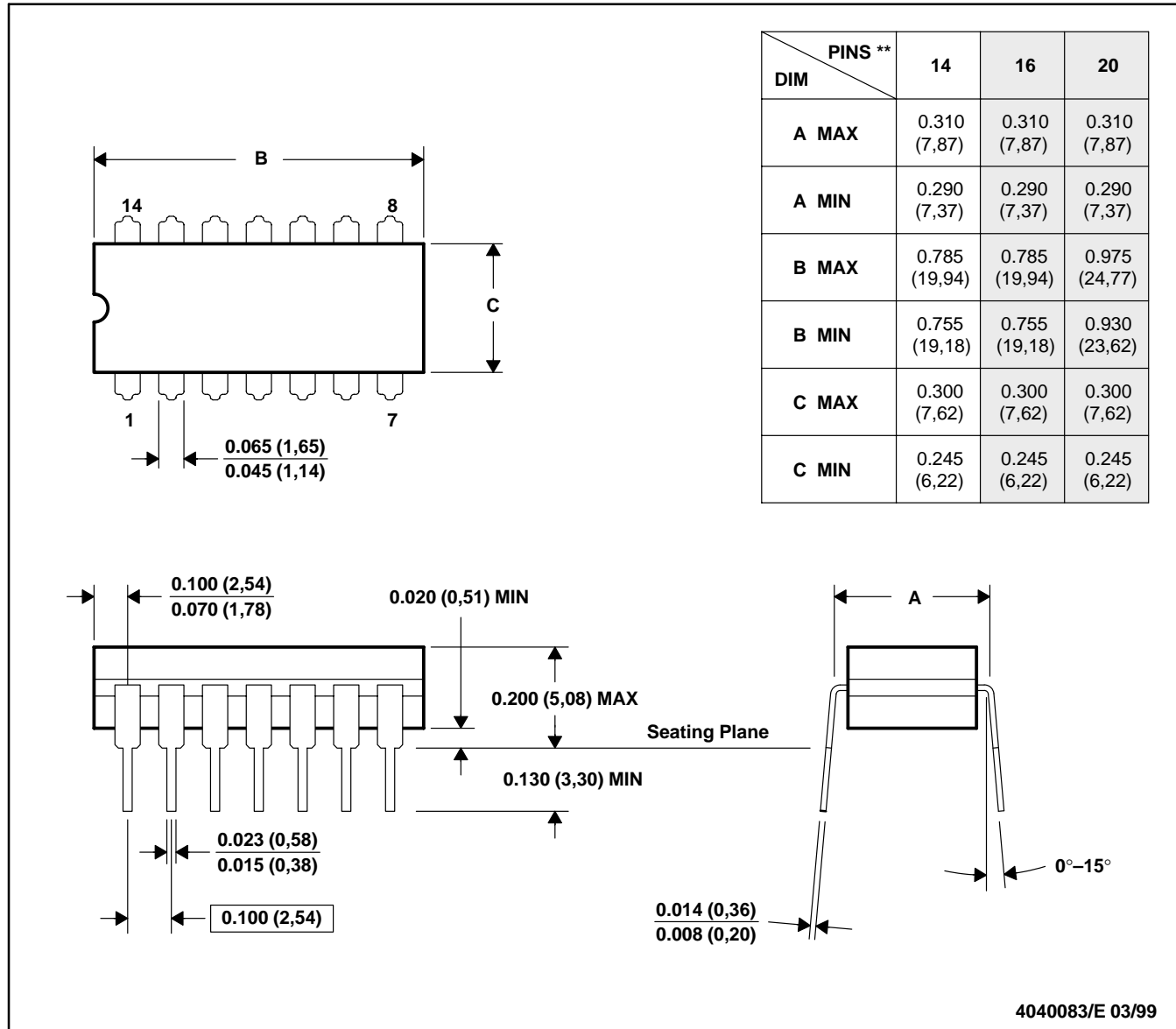
SLCS117B – NOVEMBER 1986 – REVISED JANUARY 2002

## MECHANICAL DATA

J (R-GDIP-T\*\*)

CERAMIC DUAL-IN-LINE

14 LEADS SHOWN



- NOTES: A. All linear dimensions are in inches (millimeters).  
 B. This drawing is subject to change without notice.  
 C. This package is hermetically sealed with a ceramic lid using glass frit.  
 D. Index point is provided on cap for terminal identification.  
 E. Falls within MIL STD 1835 GDIP1-T14, GDIP1-T16, and GDIP1-T20

# TLC3704, TLC3704Q QUAD MICROPOWER LinCMOS™ VOLTAGE COMPARATORS

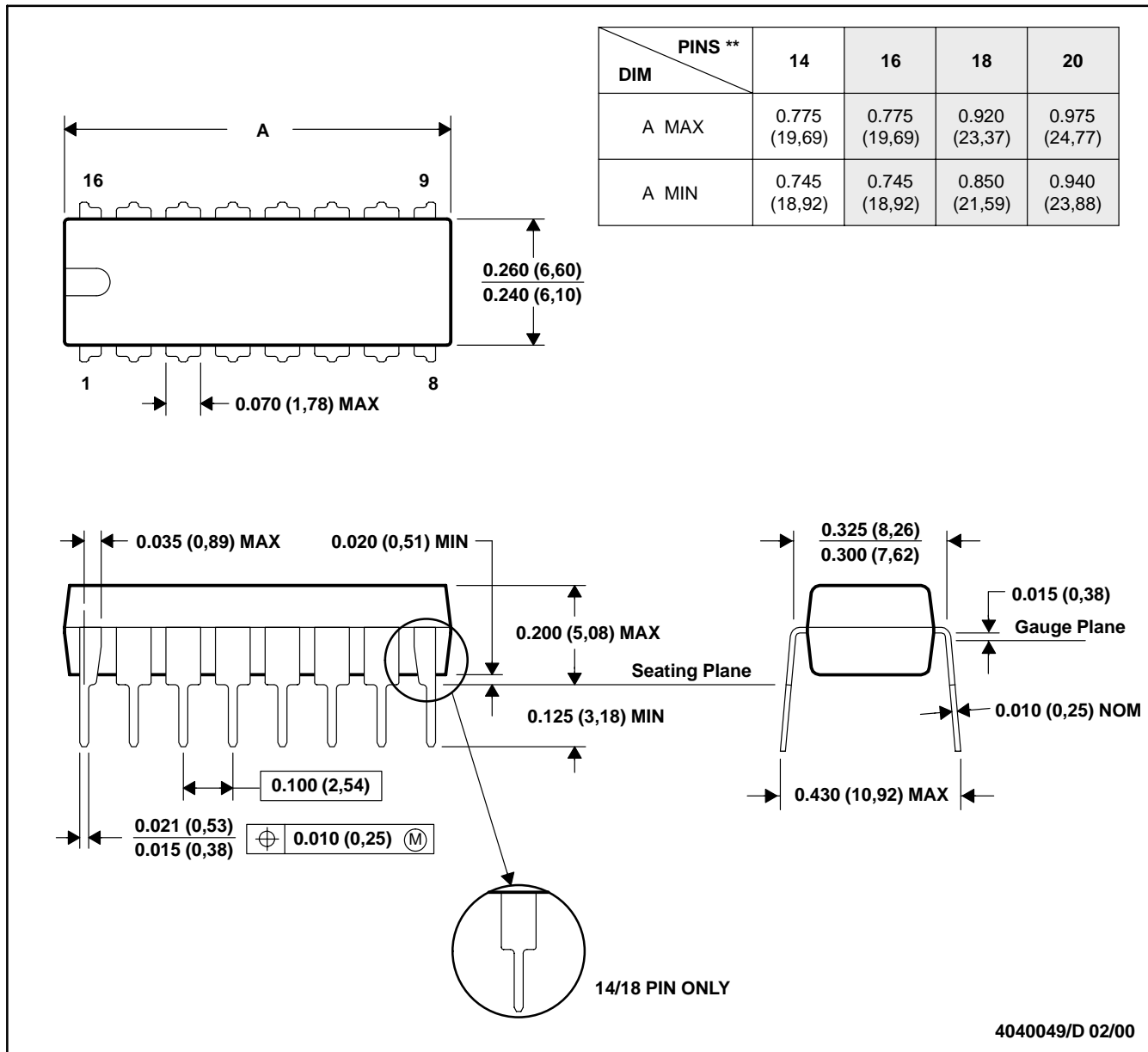
SLCS117B – NOVEMBER 1986 – REVISED JANUARY 2002

## MECHANICAL DATA

**N (R-PDIP-T\*\*)**

**PLASTIC DUAL-IN-LINE PACKAGE**

16 PINS SHOWN



- NOTES: A. All linear dimensions are in inches (millimeters).  
 B. This drawing is subject to change without notice.  
 C. Falls within JEDEC MS-001 (20-pin package is shorter than MS-001).

# TLC3704, TLC3704Q QUAD MICROPOWER LinCMOS™ VOLTAGE COMPARATORS

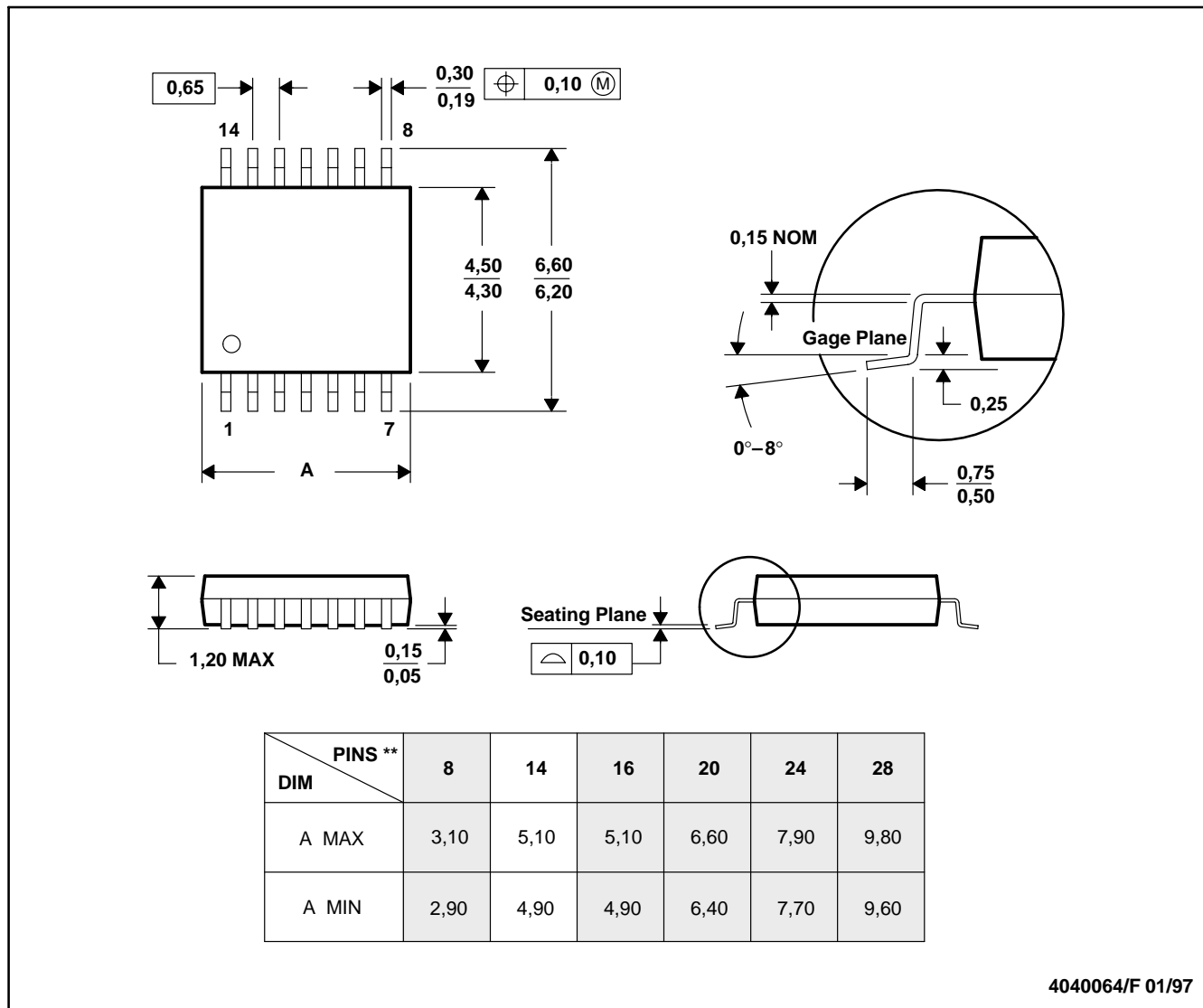
SLCS117B – NOVEMBER 1986 – REVISED JANUARY 2002

## MECHANICAL DATA

PW (R-PDSO-G\*\*)

PLASTIC SMALL-OUTLINE PACKAGE

14 PINS SHOWN



4040064/F 01/97

- NOTES: A. All linear dimensions are in millimeters.  
 B. This drawing is subject to change without notice.  
 C. Body dimensions do not include mold flash or protrusion not to exceed 0,15.  
 D. Falls within JEDEC MO-153

## PACKAGING INFORMATION

Orderable Device	Status <sup>(1)</sup>	Package Type	Package Drawing	Pins	Package Qty	Eco Plan <sup>(2)</sup>	Lead/Ball Finish	MSL Peak Temp <sup>(3)</sup>
5962-9096901M2A	ACTIVE	LCCC	FK	20	1	None	POST-PLATE	Level-NC-NC-NC
5962-9096901MCA	ACTIVE	CDIP	J	14	1	None	A42 SNPB	Level-NC-NC-NC
TLC3704CD	ACTIVE	SOIC	D	14	50	Pb-Free (RoHS)	CU NIPDAU	Level-2-260C-1YEAR/ Level-1-220C-UNLIM
TLC3704CDR	ACTIVE	SOIC	D	14	2500	Pb-Free (RoHS)	CU NIPDAU	Level-2-260C-1YEAR/ Level-1-220C-UNLIM
TLC3704CN	ACTIVE	PDIP	N	14	25	Pb-Free (RoHS)	CU NIPDAU	Level-NC-NC-NC
TLC3704CNSR	ACTIVE	SO	NS	14	2000	Pb-Free (RoHS)	CU NIPDAU	Level-2-260C-1YEAR/ Level-1-220C-UNLIM
TLC3704CPW	ACTIVE	TSSOP	PW	14	90	None	CU NIPDAU	Level-1-220C-UNLIM
TLC3704CPWLE	OBSOLETE	TSSOP	PW	14		None	Call TI	Call TI
TLC3704CPWR	ACTIVE	TSSOP	PW	14	2000	None	CU NIPDAU	Level-1-220C-UNLIM
TLC3704ID	ACTIVE	SOIC	D	14	50	Pb-Free (RoHS)	CU NIPDAU	Level-2-260C-1YEAR/ Level-1-220C-UNLIM
TLC3704IDR	ACTIVE	SOIC	D	14	2500	Pb-Free (RoHS)	CU NIPDAU	Level-2-260C-1YEAR/ Level-1-220C-UNLIM
TLC3704IN	ACTIVE	PDIP	N	14	25	Pb-Free (RoHS)	CU NIPDAU	Level-NC-NC-NC
TLC3704IPW	ACTIVE	TSSOP	PW	14	90	None	CU NIPDAU	Level-1-220C-UNLIM
TLC3704IPWR	ACTIVE	TSSOP	PW	14	2000	None	CU NIPDAU	Level-1-220C-UNLIM
TLC3704MD	ACTIVE	SOIC	D	14	50	None	CU NIPDAU	Level-1-220C-UNLIM
TLC3704MDR	ACTIVE	SOIC	D	14	2500	None	CU NIPDAU	Level-1-220C-UNLIM
TLC3704MFKB	ACTIVE	LCCC	FK	20	1	None	POST-PLATE	Level-NC-NC-NC
TLC3704MJ	ACTIVE	CDIP	J	14	1	None	A42 SNPB	Level-NC-NC-NC
TLC3704MJB	ACTIVE	CDIP	J	14	1	None	A42 SNPB	Level-NC-NC-NC

<sup>(1)</sup> The marketing status values are defined as follows:

**ACTIVE:** Product device recommended for new designs.

**LIFEBUY:** TI has announced that the device will be discontinued, and a lifetime-buy period is in effect.

**NRND:** Not recommended for new designs. Device is in production to support existing customers, but TI does not recommend using this part in a new design.

**PREVIEW:** Device has been announced but is not in production. Samples may or may not be available.

**OBSOLETE:** TI has discontinued the production of the device.

<sup>(2)</sup> Eco Plan - May not be currently available - please check <http://www.ti.com/productcontent> for the latest availability information and additional product content details.

**None:** Not yet available Lead (Pb-Free).

**Pb-Free (RoHS):** TI's terms "Lead-Free" or "Pb-Free" mean semiconductor products that are compatible with the current RoHS requirements for all 6 substances, including the requirement that lead not exceed 0.1% by weight in homogeneous materials. Where designed to be soldered at high temperatures, TI Pb-Free products are suitable for use in specified lead-free processes.

**Green (RoHS & no Sb/Br):** TI defines "Green" to mean "Pb-Free" and in addition, uses package materials that do not contain halogens, including bromine (Br) or antimony (Sb) above 0.1% of total product weight.

<sup>(3)</sup> MSL, Peak Temp. -- The Moisture Sensitivity Level rating according to the JEDEC industry standard classifications, and peak solder temperature.

**Important Information and Disclaimer:** The information provided on this page represents TI's knowledge and belief as of the date that it is provided. TI bases its knowledge and belief on information provided by third parties, and makes no representation or warranty as to the accuracy of such information. Efforts are underway to better integrate information from third parties. TI has taken and continues to take reasonable steps to provide representative and accurate information but may not have conducted destructive testing or chemical analysis on

incoming materials and chemicals. TI and TI suppliers consider certain information to be proprietary, and thus CAS numbers and other limited information may not be available for release.

In no event shall TI's liability arising out of such information exceed the total purchase price of the TI part(s) at issue in this document sold by TI to Customer on an annual basis.

## IMPORTANT NOTICE

Texas Instruments Incorporated and its subsidiaries (TI) reserve the right to make corrections, modifications, enhancements, improvements, and other changes to its products and services at any time and to discontinue any product or service without notice. Customers should obtain the latest relevant information before placing orders and should verify that such information is current and complete. All products are sold subject to TI's terms and conditions of sale supplied at the time of order acknowledgment.

TI warrants performance of its hardware products to the specifications applicable at the time of sale in accordance with TI's standard warranty. Testing and other quality control techniques are used to the extent TI deems necessary to support this warranty. Except where mandated by government requirements, testing of all parameters of each product is not necessarily performed.

TI assumes no liability for applications assistance or customer product design. Customers are responsible for their products and applications using TI components. To minimize the risks associated with customer products and applications, customers should provide adequate design and operating safeguards.

TI does not warrant or represent that any license, either express or implied, is granted under any TI patent right, copyright, mask work right, or other TI intellectual property right relating to any combination, machine, or process in which TI products or services are used. Information published by TI regarding third-party products or services does not constitute a license from TI to use such products or services or a warranty or endorsement thereof. Use of such information may require a license from a third party under the patents or other intellectual property of the third party, or a license from TI under the patents or other intellectual property of TI.

Reproduction of information in TI data books or data sheets is permissible only if reproduction is without alteration and is accompanied by all associated warranties, conditions, limitations, and notices. Reproduction of this information with alteration is an unfair and deceptive business practice. TI is not responsible or liable for such altered documentation.

Resale of TI products or services with statements different from or beyond the parameters stated by TI for that product or service voids all express and any implied warranties for the associated TI product or service and is an unfair and deceptive business practice. TI is not responsible or liable for any such statements.

Following are URLs where you can obtain information on other Texas Instruments products and application solutions:

<b>Products</b>		<b>Applications</b>	
Amplifiers	<a href="http://amplifier.ti.com">amplifier.ti.com</a>	Audio	<a href="http://www.ti.com/audio">www.ti.com/audio</a>
Data Converters	<a href="http://dataconverter.ti.com">dataconverter.ti.com</a>	Automotive	<a href="http://www.ti.com/automotive">www.ti.com/automotive</a>
DSP	<a href="http://dsp.ti.com">dsp.ti.com</a>	Broadband	<a href="http://www.ti.com/broadband">www.ti.com/broadband</a>
Interface	<a href="http://interface.ti.com">interface.ti.com</a>	Digital Control	<a href="http://www.ti.com/digitalcontrol">www.ti.com/digitalcontrol</a>
Logic	<a href="http://logic.ti.com">logic.ti.com</a>	Military	<a href="http://www.ti.com/military">www.ti.com/military</a>
Power Mgmt	<a href="http://power.ti.com">power.ti.com</a>	Optical Networking	<a href="http://www.ti.com/opticalnetwork">www.ti.com/opticalnetwork</a>
Microcontrollers	<a href="http://microcontroller.ti.com">microcontroller.ti.com</a>	Security	<a href="http://www.ti.com/security">www.ti.com/security</a>
		Telephony	<a href="http://www.ti.com/telephony">www.ti.com/telephony</a>
		Video & Imaging	<a href="http://www.ti.com/video">www.ti.com/video</a>
		Wireless	<a href="http://www.ti.com/wireless">www.ti.com/wireless</a>

Mailing Address: Texas Instruments  
Post Office Box 655303 Dallas, Texas 75265