

Stereo Digital Volume Control

Features

- Complete Digital Volume Control
 - 2 Independent Channels
 - Serial Control
 - 0.5 dB Step Size
- Wide Adjustable Range
 - -95.5 dB Attenuation
 - +31.5 dB Gain
- Low Distortion & Noise
 - 0.001% THD+N
 - 116 dB Dynamic Range
- Noise Free Level Transitions
- Channel-to-Channel Crosstalk Better Than 110 dB

Description

The CS3310 is a complete stereo digital volume control designed specifically for audio systems. It features a 16-bit serial interface that controls two independent, low distortion audio channels.

The CS3310 includes an array of well-matched resistors and a low noise active output stage that is capable of driving a 600 Ω load. A total adjustable range of 127 dB, in 0.5 dB steps, is achieved through 95.5 dB of attenuation and 31.5 dB of gain.

The simple 3-wire interface provides daisy-chaining of multiple CS3310's for multi-channel audio systems.

The device operates from ±5 V supplies and has an input/output voltage range of ±3.75 V.

ORDERING INFORMATION

CS3310-KP	0° to 70° C	16-pin Plastic DIP
CS3310-KS	0° to 70° C	16-pin Plastic SOIC

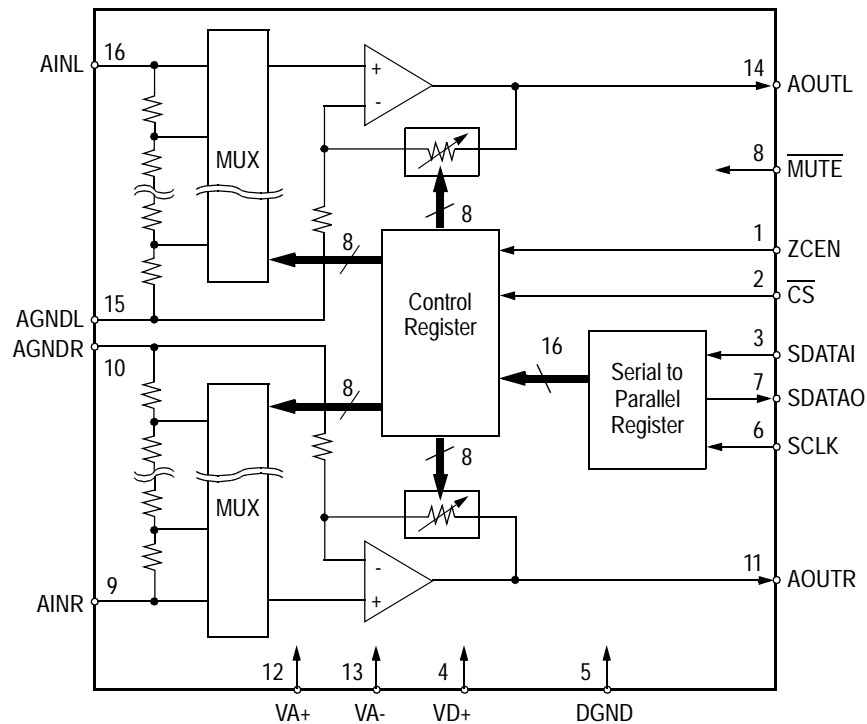

Preliminary Product Information

This document contains information for a new product. Cirrus Logic reserves the right to modify this product without notice.

ANALOG CHARACTERISTICS ($T_A = 25\text{ }^\circ\text{C}$, $V_{A+}, V_{D+} = 5\text{ V} \pm 5\%$; $V_{A-} = -5\text{ V} \pm 5\%$; $R_s = 0$; $R_L = 2\text{ k}\Omega$; $C_L = 20\text{ pF}$; 10 Hz to 20 kHz Measurement Bandwidth; unless otherwise specified)

Parameter	Symbol	Min	Typ	Max	Unit
DC Characteristics					
Step Size		-	0.5	-	dB
Gain Error (31.5 dB Gain)		-	± 0.05	-	dB
Gain Matching Between Channels		-	± 0.05	-	dB
Input Resistance	R_{IN}	8	10	-	k Ω
Input Capacitance	C_{IN}	-	10	-	pF
AC Characteristics					
Total Harmonic Distortion plus Noise ($V_{in} = 2\text{V rms}$, 1 kHz)	THD+N	-	0.001	.0025	%
Dynamic Range		110	116	-	dB
Input/Output Voltage Range		$(V_{A-})+1.25$	-	$(V_{A+})-1.25$	V
Output Noise (Note 1)		-	4.2	8.4	μVrms
Digital Feedthrough (Peak Component) (Note 2)		-80	-	-	dB
Interchannel Isolation (1 kHz) (Note 2)		-100	-110	-	dB
Output Buffer					
Offset Voltage (Note 1)	V_{OS}	-	0.25	0.75	mV
Load Capacitance		-	-	100	pF
Short Circuit Current		-	20	-	mA
Unity Gain Bandwidth, Small Signal (Note 2)		2	-	-	MHz
Power Supplies					
Supply Current (No Load, $A_{IN} = 0\text{ V}$)	I_{A+}	-	5.0	8.0	mA
	I_{A-}	-	5.0	8.0	mA
	I_{D+}	-	350	800	μA
Power Consumption	P_D	-	52.0	84.0	mW
Power Supply Rejection Ratio (250 Hz)	PSRR	-	80	-	dB

- Notes: 1. Measured with input grounded and Gain = 1. Will increase as a function of Gain settings >1.
2. This parameter is guaranteed by design and/or characterization.

DIGITAL CHARACTERISTICS ($T_A = 25\text{ }^\circ\text{C}$, V_{A+} , $V_{D+} = 5V \pm 5\%$, $V_{A-} = -5V \pm 5\%$)

Parameter	Symbol	Min	Typ	Max	Unit
High-Level Input Voltage	V_{IH}	2.0	-	$V_{D+}+0.3$	V
Low-Level Input Voltage	V_{IL}	-0.3	-	+0.8	V
High-Level Output Voltage ($I_O = 200\mu\text{A}$)	V_{OH}	$V_{D-}-1.0$	-	-	V
Low-Level Output Voltage ($I_O = 3.2\text{mA}$)	V_{OL}	-	-	0.4	V
Input Leakage Current	I_{in}	-	1.0	10	μA

SWITCHING CHARACTERISTICS ($T_A = 25\text{ }^\circ\text{C}$; V_{A+} , $V_{D+} = +5V \pm 5\%$; $V_{A-} = -5V \pm 5\%$; $C_L = 20\text{ pF}$)

Parameter	Symbol	Min	Typ	Max	Unit
Serial Clock	SCLK	0	-	-	MHz
Serial Clock	Pulse Width High	t_{ph}	80	-	ns
	Pulse Width Low	t_{pl}	80	-	ns
$\overline{\text{MUTE}}$	Pulse Width Low	-	2.0	-	ms
Input Timing					
SDATAI Set Up Time	t_{SDVS}	20	-	-	ns
SDATAI Hold Time	t_{SDH}	20	-	-	ns
$\overline{\text{CS}}$ Valid to SCLK Rising	t_{CSVS}	30	-	-	ns
SCLK Falling to $\overline{\text{CS}}$ High	t_{LTH}	35	-	-	ns
Output Timing					
$\overline{\text{CS}}$ Low to Output Active	t_{CSH}	-	-	35	ns
SCLK Falling to Data Valid	t_{SSD}	-	-	60	ns
$\overline{\text{CS}}$ High to SDATAO Inactive	t_{CSDH}	-	-	100	ns

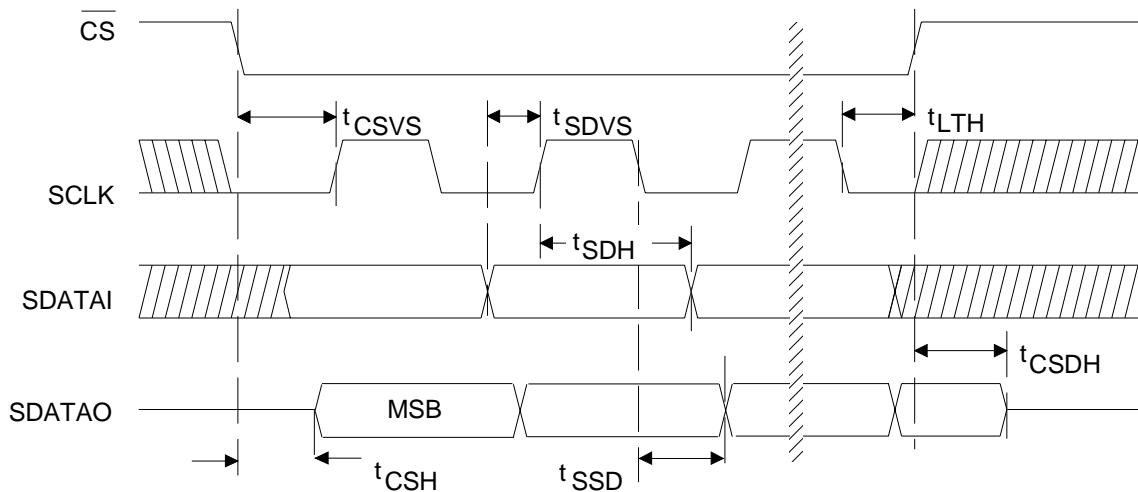
Figure 1. Serial Port Timing Diagram

RECOMMENDED OPERATING CONDITIONS (DGND = 0V; all voltages with respect to ground)

Parameter	Symbol	Min	Typ	Max	Unit
DC Power Supplies:					
Positive Digital	VD+	4.75	5.0	VA+	V
Positive Analog	VA+	4.75	5.0	5.25	V
Negative Analog	VA	-4.75	-5.0	-5.25	V
(VD+) - (VA+) (Note 3)	-	-0.3	-	0.0	V
Ambient Operating Temperature	T _A	0	25	70	°C

Notes: 3. Applying power to VD+ prior to VA+ creates a SCR latch-up condition. Refer to Figure 2 for the recommended power connections.

ABSOLUTE MAXIMUM RATINGS (AGND, DGND = 0V, all voltages with respect to ground.)

Parameter	Symbol	Min	Max	Unit
DC Power Supplies:				
Positive Digital	VD+	-0.3	(VA+)+ 0.3	V
Positive Analog	VA+	-0.3	6.0	V
Negative Analog	VA-	0.3	-6.0	V
Input Current, Any Pin Except Supply	I _{in}	-	±10	mA
Digital Input Voltage	V _{IND}	-0.3	(VA+) + 0.3	V
Ambient Operating Temperature (power applied)	T _A	-55	+125	°C
Storage Temperature	T _{STG}	-65	+150	°C

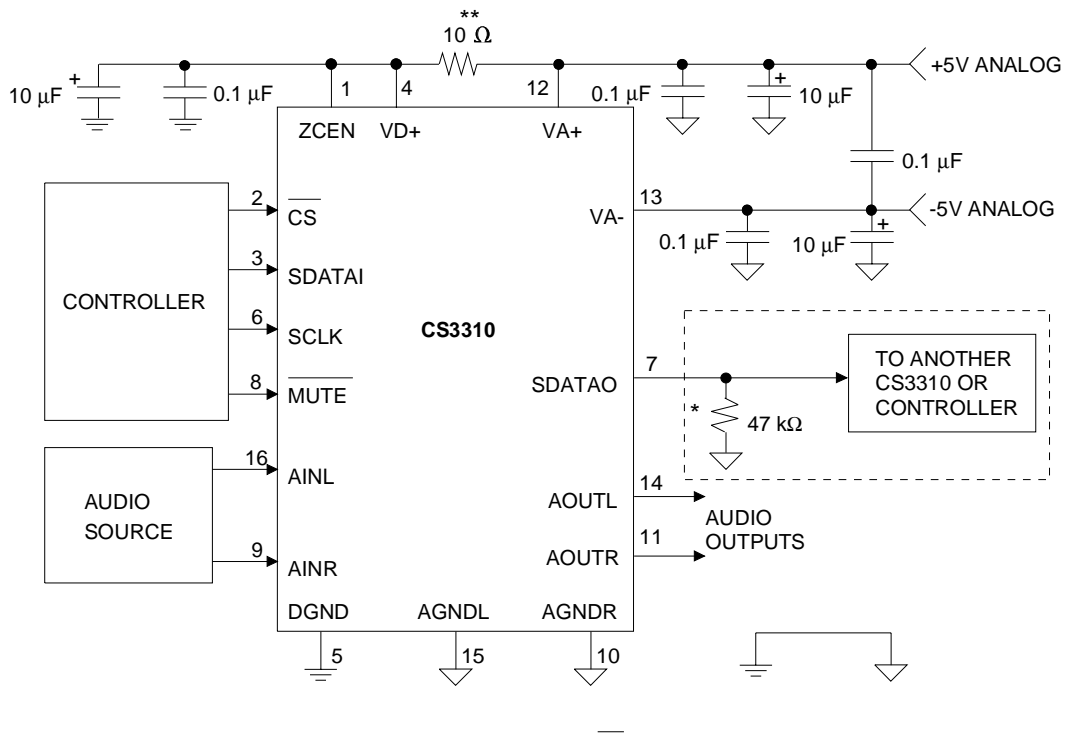

*Required to terminate SDATAI due to high impedance state of SDATAO when CS is high.
 **Refer to Note 3.

Figure 2. Recommended Connection Diagram

GENERAL DESCRIPTION

The CS3310 is a stereo, digital volume control designed for audio systems. The levels of the left and right analog input channels are set by a 16-bit serial data word; the first 8 bits address the right channel and the remaining 8 bits address the left channel, as detailed in Table 1. Resistor values are decoded to 0.5 dB resolution by an internal multiplexer for a total attenuation range of -95.5 dB. An output amplifier stage provides a programmable gain of up to 31.5 dB in 0.5 dB steps. This results in an overall 8-bit adjustable range of 127 dB.

The CS3310 operates from ± 5 V supplies and accepts inputs up to ± 3.75 V. Once in operation, the CS3310 can be brought to a muted state with the mute pin, $\overline{\text{MUTE}}$, or by writing all zeros to the volume control registers. The device contains a simple three wire serial interface which accepts 16-bit data. This interface also supports daisy-chaining capability.

SYSTEM DESIGN

Very few external components are required to support the CS3310. Normal power supply decoupling components are all that is required, as shown in Figure 2.

Serial Data Interface

The CS3310 has a simple, three wire interface that consists of three input pins: SDATAI, serial data input; SCLK, serial data clock and $\overline{\text{CS}}$, the chip select input. SDATAO, serial data output, enables the user to read the current volume setting or provide daisy-chaining of multiple CS3310's.

The 16-bit serial data is formatted MSB first and clocked into SDATAI by the rising edge of SCLK with $\overline{\text{CS}}$ low as shown in Figure 3. The data is latched by the rising edge of $\overline{\text{CS}}$ and the analog output levels of both left and right channels are set. The existing data in the volume control data register is clocked out SDATAO on the falling edge of SCLK. This data can be used to read current gain/attenuation levels or to daisy chain multiple CS3310's. See Figure 1 for proper setup and hold times for $\overline{\text{CS}}$, SDATAI, SCLK, and SDATAO. SCLK and SDATAI should be active only during volume setting operations to achieve optimum dynamic range.

Daisy Chaining

Digitally controlled, multi-channel audio systems often result in complex address decoding which complicates PCB layout. This is greatly simplified with the daisy-chaining capability of the CS3310.

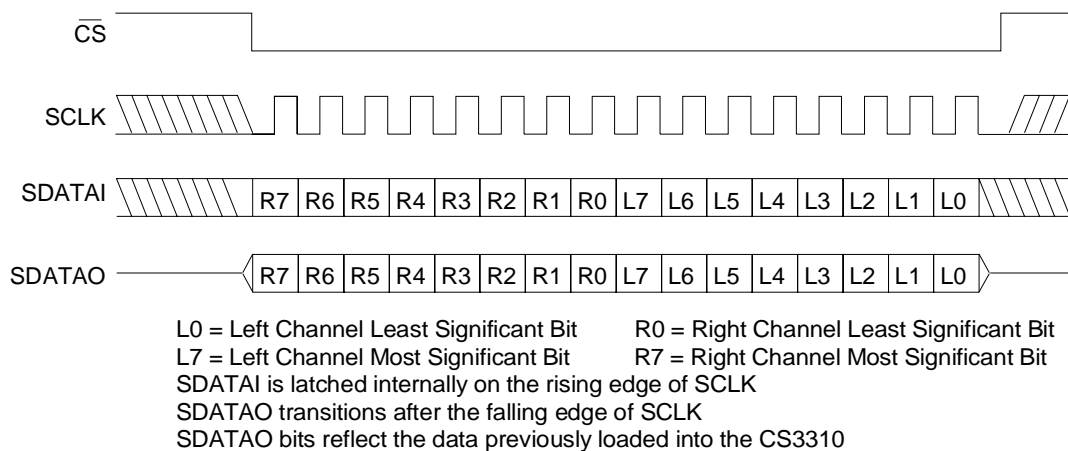

Figure 3. Serial Port Timing

In single device operation, volume control data is loaded into the 16-bit shift register by holding the \overline{CS} pin low for sixteen SCLK pulses and then latched on the rising edge of \overline{CS} . The previous contents of the shift-register are shifted through the register and out SDATAO during the process.

Multi-channel operation can be implemented as shown in Figure 4 by connecting the SDATAO of device #1 to the SDATAI pin of device #2. In this manner multiple CS3310s can be loaded from a single serial data line without complex addressing schemes. Volume control data is loaded by holding \overline{CS} low for $16 \times N$ SCLK pulses, where N is the number of devices in the chain. The 16 bits clocked into device #1 on SCLK pulses 1-16 are clocked into device #2 on SCLK pulses 17-32. The CS3310s are simultaneously updated on the rising edge of \overline{CS} following $16 \times N$ SCLK pulses. Notice that a 47 kohm resistor is required to terminate SDATAI, as shown in Figure 4, due to the high impedance state of SDATAO when \overline{CS} is high.

Changing the Analog Output Level

Care has been taken to ensure that there are no audible artifacts in the analog output signal during

volume control changes. The gain/attenuation changes of the CS3310 occur at zero crossings to eliminate glitches during level transitions. The zero crossing for the left channel is the voltage potential at the AGNDL pin; the voltage potential at the AGNDR pin defines the right channel zero crossing.

A volume control change occurs after chip select latches the data in the volume control data register and two zero crossings are detected. If two zero crossings are not detected within 18 ms of the change in \overline{CS} , the new volume setting is implemented. The zero crossing enable pin, ZCEN, enables or disables the zero crossing detection function as well as the 18 ms time-out circuit.

Input Code (Left or Right Channel)	Gain or Attenuation (dB)
11111111	+31.5
11111110	+31.0
•	•
•	•
11000000	0
•	•
00000010	-95.0
00000001	-95.5
00000000	Software Mute

Table 1. Input Code Definition

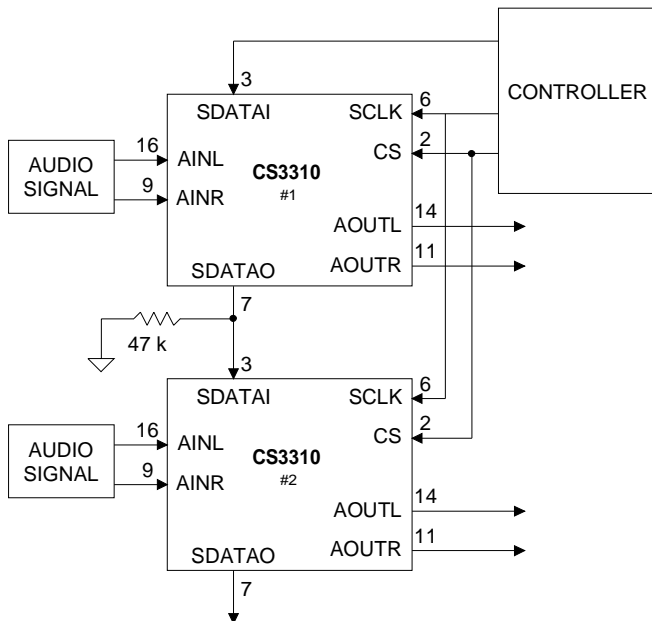

Figure 4. Daisy Chaining Diagram

Analog Inputs and Outputs

The maximum input level is limited by the common-mode voltage capabilities of the internal op-amp. Signals approaching the analog supply voltages may be applied to the AIN pins if the internal attenuator limits the output signal to within 1.25 volts of the analog supply rails.

The outputs are capable of driving 600 Ω loads to within 1.25 volts of the analog supply rails and are short circuit protected to 20 mA.

As with any adjustable gain stage the affects of a DC offset at the input must be considered. Capacitively coupling the analog inputs may be required

to prevent “clicks and pops” which occur with gain changes if an appreciable offset is present.

Source Impedance Requirements

The CS3310 requires a low source impedance to achieve maximum performance. The ESD protection diodes on the analog input pins are reversed biased during normal operation. A characteristic of a reversed biased diode is a non-linear voltage dependent capacitance which can be a source of distortion if the source impedance becomes appreciable relative to the reversed biased diode capacitance. Source impedances equal to or less than 600 ohms will avoid this distortion mechanism for the CS3310.

Mute

Muting can be achieved by either hardware or software control. Hardware muting is accomplished via the $\overline{\text{MUTE}}$ input and software muting by loading all zeroes into the volume control register.

$\overline{\text{MUTE}}$ disconnects the internal buffer amplifiers from the output pins and terminates AOUTL and AOUTR with 10 k Ω resistors to ground. The mute is activated with a zero crossing detection (independent of the zero cross enable status) or an 18 ms timeout to eliminate any audible “clicks” or “pops”. $\overline{\text{MUTE}}$ also initiates an internal offset calibration.

A software mute is implemented by loading all zeroes into the volume control register. The internal amplifier is set to unity gain with the amplifier input connected to the maximum attenuation point of the resistive divider, AGND.

A “soft mute” can be accomplished by sequentially ramping down from the current volume control setting to the maximum attenuation code of all zeroes.

Power-Up Considerations

Upon initial application of power, the $\overline{\text{MUTE}}$ pin of the CS3310 should be set low to initiate a power-up sequence. This sequence sets the serial shift regis-

ter and the volume control register to zero and performs an offset calibration. The device should remain muted until the supply voltages have settled to ensure an accurate calibration. The device also includes an internal power-on reset circuit that requires approximately 100 μs to settle and will ignore any attempts to address the internal registers during this period.

The offset calibration minimizes internally generated offsets and ignores offsets applied to the AIN pins. External clocks are not required for calibration.

Although the device is tolerant to power supply variation, the device will enter a hardware mute state if the power supply voltage drops below approximately ± 3.5 volts. A power-up sequence will be initiated if the power supply voltage returns to greater than ± 3.5 volts.

Applying power to VD+ prior to VA+ creates a SCR latch-up condition. Refer to Figure 2 for the recommended power connections.

PCB Layout, Grounding and Power Supply Decoupling

As with any high performance device which contains both analog and digital circuitry, careful attention to power supply and grounding arrangements must be observed to optimize performance. Figure 2 shows the recommended power arrangements with VA+ connected to a clean +5 volt supply and VA- connected to a clean -5 volt supply. VD+ powers the digital interface circuitry and should be powered from VA+, as shown in Figure 2, to avoid potentially destructive SCR latch-up. Decoupling capacitors should be located as near to the CS3310 as possible, see Figure 5.

The printed circuit board layout should have separate analog and digital regions with individual ground planes. The CS3310 should reside in the analog region as shown in Figure 5. Care should be taken to ensure that there is minimal resistance in

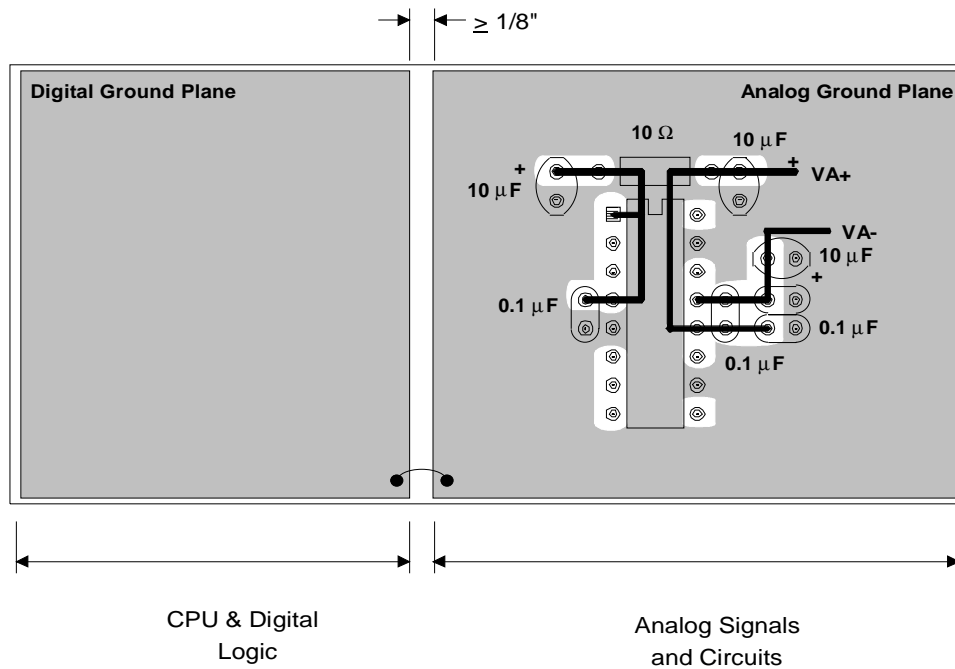

Figure 5. Recommended 2-Layer PCB Layout

the analog ground leads to the device to prevent any change in the defined attenuation settings. Extensive use of ground plane fill on both the analog and digital sections of the circuit board will yield large reductions in radiated noise effects.

Performance Plots

Figure 8 displays the CS3310 frequency response with a 3.75 V_p output.

Figure 9 shows the frequency response with a 0.375 V_p output.

Figure 6 is the Total Harmonic Distortion + Noise vs. amplitude at 1 kHz. The upper trace is the THD+N vs. amplitude of the CS3310. The lower trace is the THD+N of the Audio Precision System One generator output connected directly to the analyzer input. The System One panel settings are identical to the previous test. This indicates that the THD+N contribution of the Audio Precision actu-

ally degrades the measured performance of the CS3310 below 2.7 V_{rms} signal levels.

Figure 7 is a 16k FFT plot demonstrating the crosstalk performance of the CS3310 at 20 kHz. Both channels were set to unity gain. The right channel input is grounded with the left channel driven to 2.65 V_{rms} output at 20 kHz. The FFT plot is of the right channel output. This indicates channel to channel crosstalk of -130 dB at 20 kHz.

Figure 10 is a series of plots which display the unity-gain THD+N vs. Frequency for 600 Ω, 2 kΩ and infinite load conditions. The output was set to 2 V_{rms}. The Audio Precision System One was bandlimited to 22 kHz.

Figure 11 is a series of plots which display the unity-gain THD+N vs. Frequency for 1, 2 and 2.8 V_{rms} output levels. The output load was open circuit. The Audio Precision System One was bandlimited to 22 kHz.

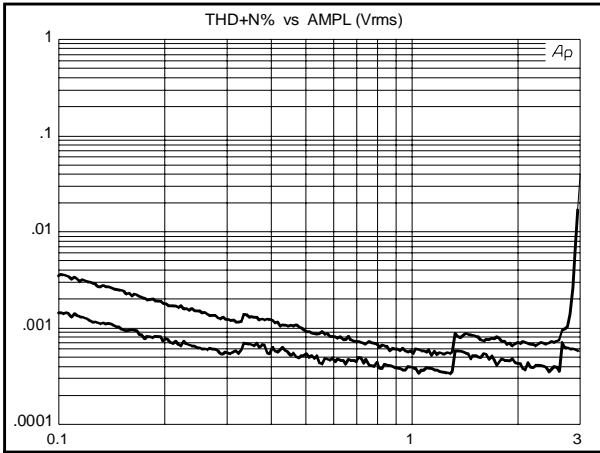

Figure 6. THD+N vs. AMP

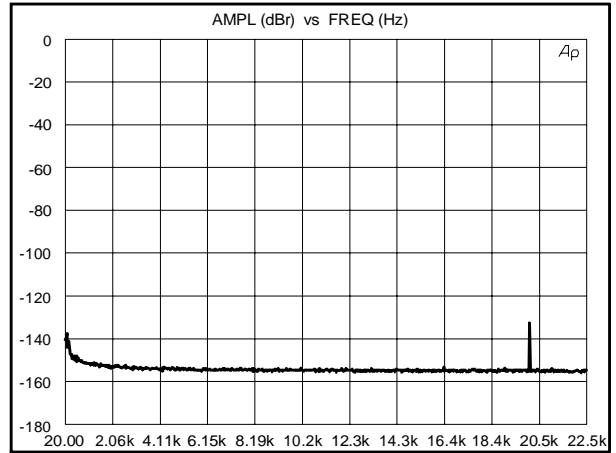

Figure 7. 20 kHz Crosstalk

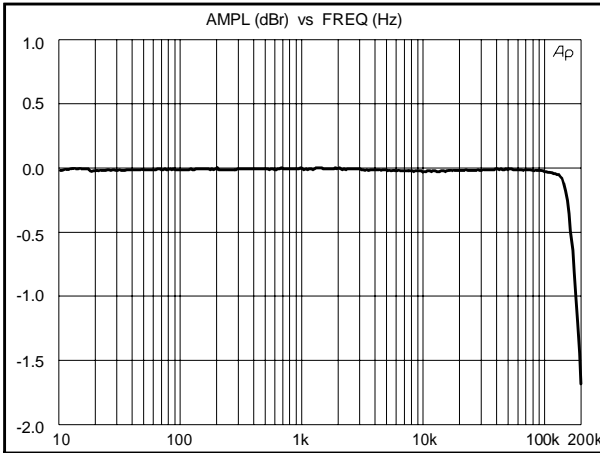

Figure 8. Frequency Response Full Scale Input

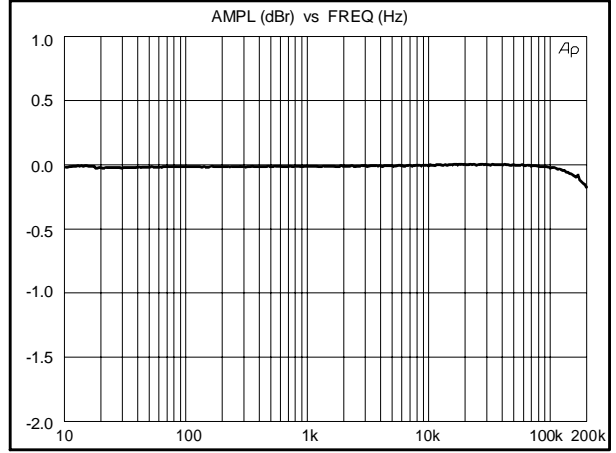

Figure 9. Frequency Response -20 dB Input

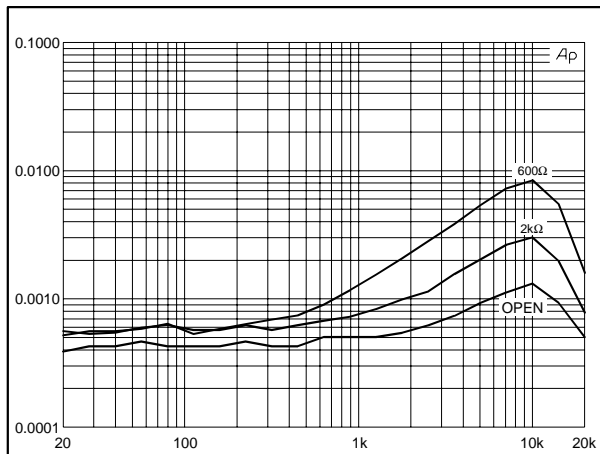

Figure 10. THD+N vs. Frequency LOAD = 600 Ω, 2 kΩ, open ckt

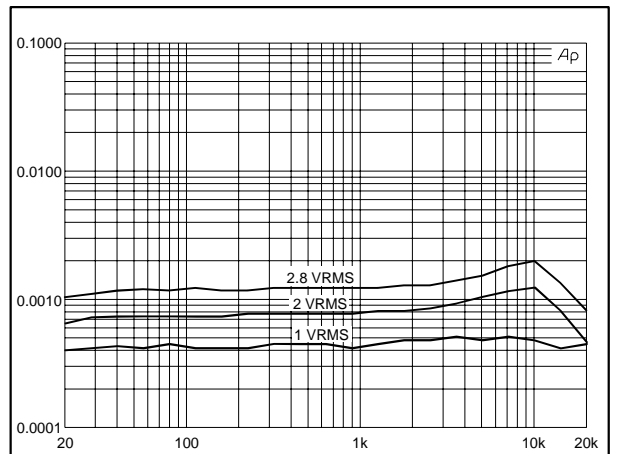
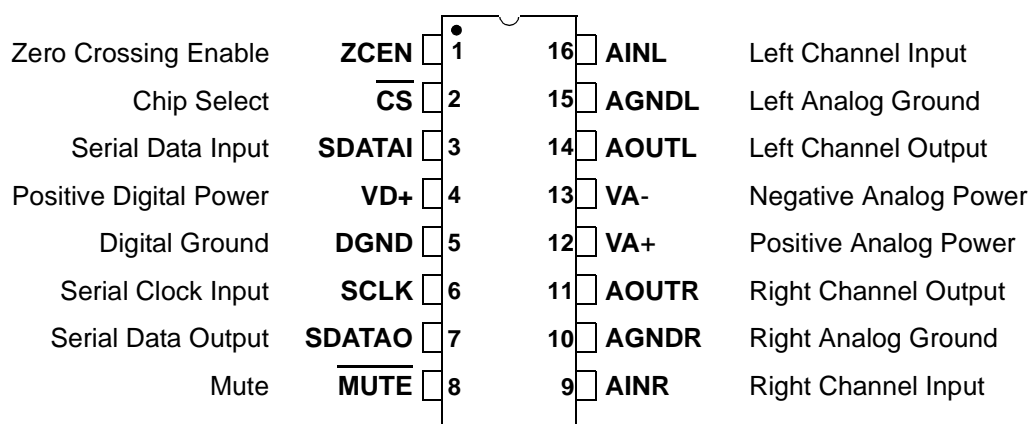

Figure 11. THD+N vs. Frequency Output levels of 1, 2, and 2.8 Vrms

PIN DESCRIPTION

Power Supply Connections
VA+ - Positive Analog Power, Pin 12.

Positive analog supply. Nominally +5 volts.

VA- - Negative Analog Power, Pin 13.

Negative analog supply. Nominally -5 volts.

AGNDL - Left Channel Analog Ground, Pin 15.

Analog ground reference for the left channel.

AGNDR - Right Channel Analog Ground, Pin 10.

Analog ground reference for the right channel.

VD+ - Positive Digital Power, Pin 4.

Positive supply for the digital section. Nominally +5 volts. Applying power to VD+ prior to VA+ creates a SCR latch-up condition. Refer to Figure 2 for the recommended power connections.

DGND - Digital Ground, Pin 5.

Digital ground for the digital section.

Analog Inputs and Outputs

AINL, AINR - Left and Right Channel Analog Inputs, Pins 16, 9.

Analog input connections for the left and right channels. Nominally ± 3.75 volts for a full scale input.

AOUTL, AOUTR - Left and Right Channel Analog Outputs, Pins 14, 11.

Analog outputs for the left and right channels. Nominally ± 3.75 volts for a full scale output.

Digital Pins

SDATAI - Serial Data Input, Pin 3.

Serial input data that sets the analog output level of the left and right channels. The data is formatted in a 16-bit word. The first eight bits clocked into this pin control the analog output level for the right channel, and the second eight bits clocked into the device control the analog output level for the left channel. The data is clocked into the CS3310 by the rising edge of SCLK.

SDATAO - Serial Data Output, Pin 7.

Serial output data that provides daisy-chaining of multiple CS3310's. This serial output will output the previous sixteen bits of volume control data that were clocked into the SDATAI pin. SDATAO will enter a High Impedance State when $\overline{\text{CS}}$ is High.

SCLK - Serial Input Clock, Pin 6.

Serial clock that clocks in the individual bits of serial data from the SDATAI pin. This clock is also used to clock out the individual bits from the SDATAO pin. The SDATAI data is latched on the rising edge, and SDATAO data is clocked out on the falling edge.

$\overline{\text{CS}}$ - Chip Select, Pin 2.

When high, the SDATAO output is held in a high impedance state. A falling transition defines the start of the 16-bit volume control word into the device. The 16-bit input data is latched into the control register on the rising edge of $\overline{\text{CS}}$.

$\overline{\text{MUTE}}$ - Mute, Pin 8.

Forces both the left and right analog output channels to ground. An offset calibration is initiated following the low transition of $\overline{\text{MUTE}}$. Calibration requires a minimum mute period of 2 ms.

ZCEN - Zero Crossing Enable, Pin 1.

This pin enables or disables the zero crossing detection and time-out function used during analog output level transitions. A high level on this pin enables the zero crossing detection function. A low level on this pin disables the zero crossing detection.

PARAMETER DEFINITIONS**Dynamic Range**

Full scale (RMS) signal to broadband noise ratio. The broadband noise is measured over the specified bandwidth with the input grounded. Units in decibels.

Total Harmonic Distortion plus Noise

The ratio of the rms value of the signal to the rms sum of all other spectral components over the specified bandwidth (typically 10 Hz to 20 kHz), including distortion components. Expressed in decibels.

Interchannel Isolation

A measure of crosstalk between the left and right channels. Measured for each channel at the converter's output with the input under test grounded and a full-scale signal applied to the other channel. Units in decibels.

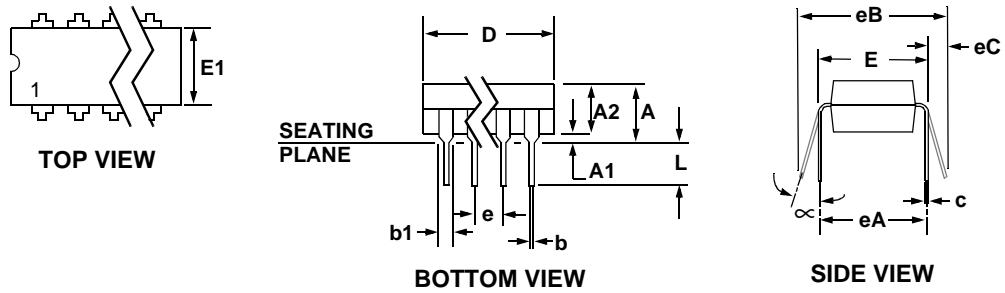
PACKAGE DIMENSIONS
16 PIN PLASTIC (PDIP) PACKAGE DRAWING

DIM	INCHES		MILLIMETERS	
	MIN	MAX	MIN	MAX
A	0.000	0.210	0.00	5.33
A1	0.015	0.025	0.38	0.64
A2	0.115	0.195	2.92	4.95
b	0.014	0.022	0.36	0.56
b1	0.045	0.070	1.14	1.78
c	0.008	0.014	0.20	0.36
D	0.780	0.800	19.81	20.32
E	0.300	0.325	7.62	8.26
E1	0.240	0.280	6.10	7.11
e	0.090	0.110	2.29	2.79
eA	0.280	0.320	7.11	8.13
eB	0.300	0.430	7.62	10.92
eC	0.000	0.060	0.00	1.52
L	0.115	0.150	2.92	3.81
∞	0°	15°	0°	15°

16L SOIC (300 MIL BODY) PACKAGE DRAWING

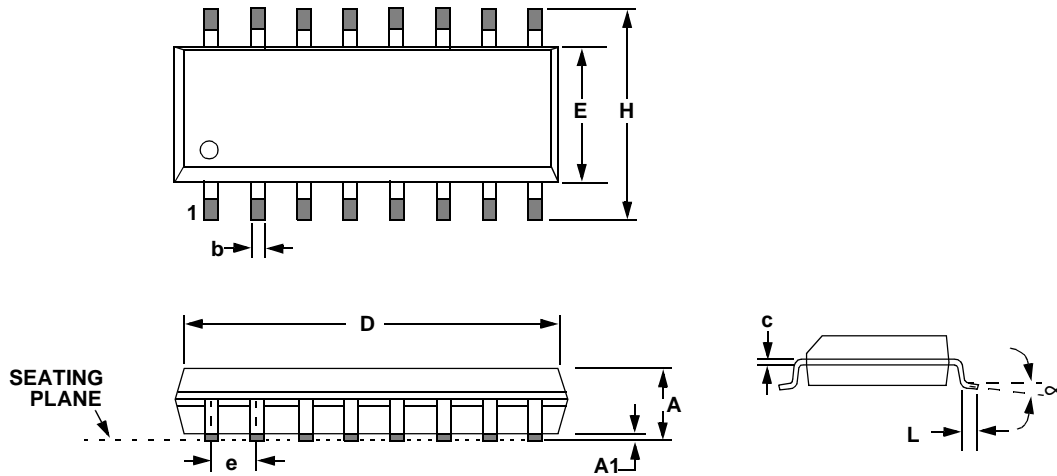

DIM	INCHES		MILLIMETERS	
	MIN	MAX	MIN	MAX
A	0.093	0.104	2.35	2.65
A1	0.004	0.012	0.10	0.30
B	0.013	0.020	0.33	0.51
C	0.009	0.013	0.23	0.32
D	0.398	0.413	10.10	10.50
E	0.291	0.299	7.40	7.60
e	0.040	0.060	1.02	1.52
H	0.394	0.419	10.00	10.65
L	0.016	0.050	0.40	1.27
∞	0°	8°	0°	8°

JEDEC #: MS-013

Evaluation Board for CS3310

Features

- Demonstrates recommended layout and grounding arrangements
- On-board or externally supplied system control
- Buffered PC Control Interface
- Digital and Analog Patch Areas

General Description

The CDB3310 evaluation board allows fast evaluation of the CS3310 stereo digital volume control. The board generates all control signals. Evaluation requires a low-distortion signal source and a power supply.

The evaluation board may be configured to accept external timing signals for operation in a user application during system development. The CDB3310 also provides a PC compatible control port for user software development.

Analog inputs and outputs are standard RCA phono plugs.

ORDERING INFORMATION: CDB3310

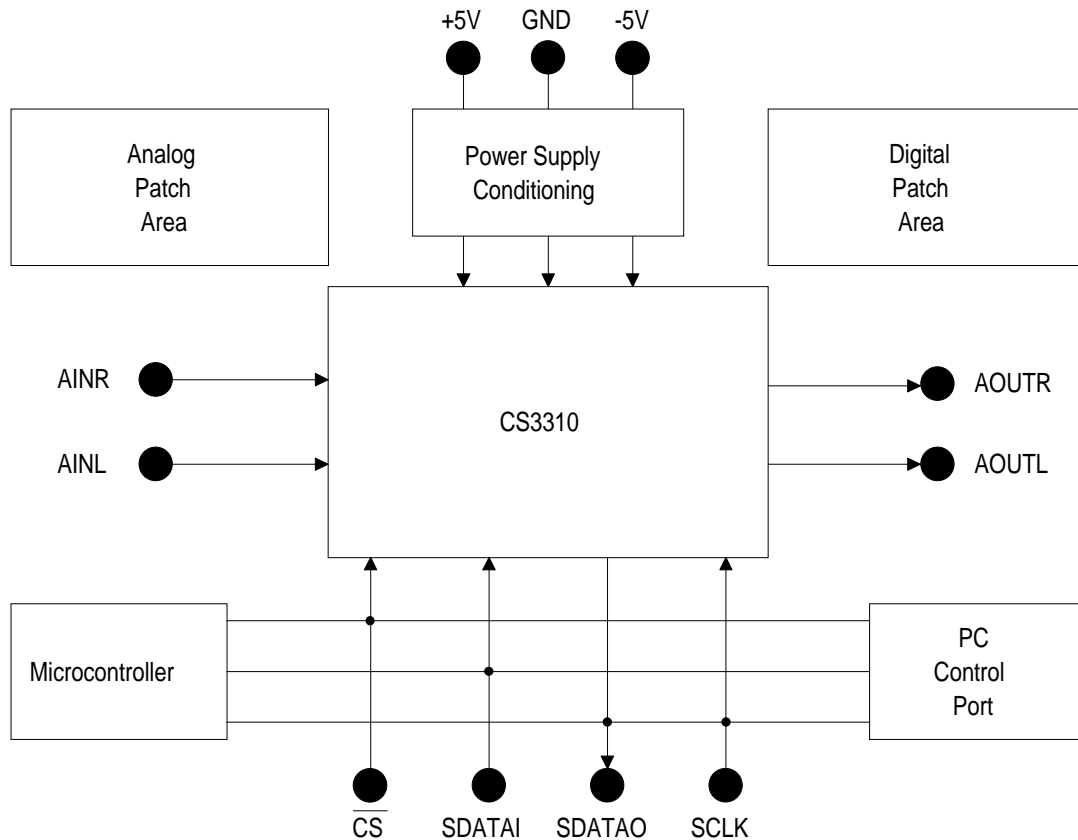

• **Notes** •



Preliminary product information describes products which are in production, but for which full characterization data is not yet available. Cirrus Logic, Inc. has made best efforts to ensure that the information contained in this document is accurate and reliable. However, the information is subject to change without notice and is provided "AS IS" without warranty of any kind (express or implied). No responsibility is assumed by Cirrus Logic, Inc. for the use of this information, nor for infringements of patents or other rights of third parties. This document is the property of Cirrus Logic, Inc. and implies no license under patents, copyrights, trademarks, or trade secrets. No part of this publication may be copied, reproduced, stored in a retrieval system, or transmitted, in any form or by any means (electronic, mechanical, photographic, or otherwise). Furthermore, no part of this publication may be used as a basis for manufacture or sale of any items without the prior written consent of Cirrus Logic, Inc. The names of products of Cirrus Logic, Inc. or other vendors and suppliers appearing in this document may be trademarks or service marks of their respective owners which may be registered in some jurisdictions. A list of Cirrus Logic, Inc. trademarks and service marks can be found at <http://www.cirrus.com>.