



# Alternator Voltage Regulator FET Driver

## Description

The CS3361 integral alternator regulator integrated circuit provides the voltage regulation for automotive, 3-phase alternators.

It drives an external logic level N channel enhancement power FET for control of the alternator field current. In the event of a charge

fault, a lamp output pin is provided to drive an external darlington transistor capable of switching on a fault indicator lamp. An overvoltage or no Stator signal condition activates the lamp output.

The CS3361 is available in a 14 lead SO package.

## Features

- Drives Logic Level Power NFET
- 80V Load Dump
- Temperature Compensated Regulation Voltage
- Shorted Field Protection Duty Cycle, Self Clearing

## Absolute Maximum Ratings

Storage Temperature Range .....	-55°C to +165°C
Junction Temperature Range .....	-40°C to +150°C
Continuous Supply .....	.27V
I <sub>CC</sub> Load Dump .....	400 mA
Lead Temperature Soldering	
Reflow (SMD styles only).....	60 sec. max above 183°C, 230°C peak

## Block Diagram

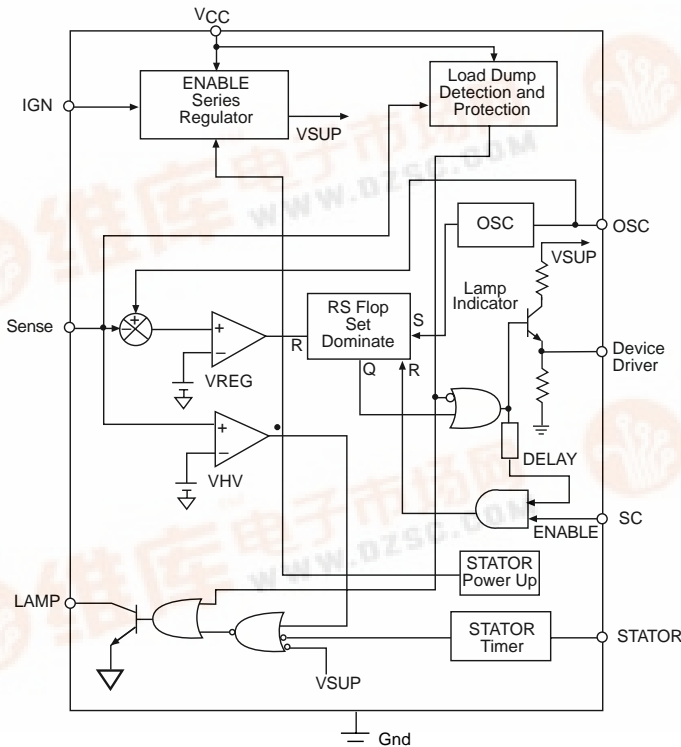

## Package Options



**Electrical Characteristics:  $-40^{\circ}\text{C} < T_A < 125^{\circ}\text{C}$ ,  $-40^{\circ}\text{C} < T_j < 150^{\circ}\text{C}$ ,  $9\text{V} \leq V_{CC} \leq 17\text{V}$ ; unless otherwise specified.**

PARAMETER	TEST CONDITIONS	MIN	TYP	MAX	UNIT
<b>■ Supply</b>					
Supply Current Enabled		–		10	mA
Supply Current Disabled		–		50	$\mu\text{A}$
<b>■ Driver Stage</b>					
Output High Voltage		5.5		12	V
Output High Current	$V_{DD} = 1.2\text{V}$	-10	-6	-4	mA
Output Low Voltage	$I_{OL} = 25\mu\text{A}$	–		0.35	V
Minimum ON Time	$C_{OSC} = 0.022\mu\text{F}$	200			$\mu\text{s}$
Minimum Duty Cycle		–	6	10	%
Short Circuit Duty Cycle		1		5	%
Field Switch Turn On					
Rise Time		15		75	$\mu\text{s}$
Fall Time		15		75	$\mu\text{s}$
<b>■ Stator</b>					
Input High Voltage		10			V
Input Low Voltage		–		6	V
Stator Time Out	High to Low	6	100	600	ms
<b>■ Lamp</b>					
Output High Current	$V_{LAMP} @ 3\text{V}$	–		50	$\mu\text{A}$
Output Low Voltage	$I_{LAMP} @ 30\text{mA}$	–		0.35	V
<b>■ Ignition</b>					
Input High Voltage	$I_{CC} > 1\text{mA}$	1.8		–	V
Input Low Voltage	$I_{CC} < 100\mu\text{A}$	–		0.5	V
<b>■ Oscillator</b>					
Oscillator Frequency	$C_{OSC} = 0.022\mu\text{F}$	90		210	Hz
Rise Time/Fall Time	$C_{OSC} = 0.022\mu\text{F}$		17	–	–
Oscillator High Threshold	$C_{OSC} = 0.022\mu\text{F}$	–		4.5	V
<b>■ Battery Sense</b>					
Input Current		-10		+10	$\mu\text{A}$
Regulation Voltage	@ $25^{\circ}\text{C}$ , $R_1 = 100\text{k}\Omega$ , $R_2 = 50\text{k}\Omega$	13.8		15.8	V
Proportional Control		0.10		0.25	V
High Voltage	$V_{\text{High Voltage @ Lamp On}}$	1.083		1.190	
Threshold Ratio	$V_{\text{Regulation @ 50% Duty Cycle}}$				
High Voltage Hysteresis		0.020		0.600	V

## Package Pin Description

PACKAGE PIN #	PIN SYMBOL	FUNCTION
<b>14 Lead SO</b>		
1	Driver	Output driver for external power switch.
2	Gnd	Ground.
3, 6, 7, 9, 13	NC	No connection.
4	OSC	Timing capacitor for oscillator.
5	Lamp	Base driver for lamp driver indicates no stator signal or over-voltage condition.
8	IGN	Switched ignition power up.
10	Stator	Stator signal input for stator timer.
11	Sense	Battery sense voltage regulator comparator input and protection.
12	V <sub>CC</sub>	Supply for IC.
14	SC	Short circuit sensing.

## Typical Performance Characteristics

CS3361 Battery Voltage vs Temperature (°C)  
Over Process Variation

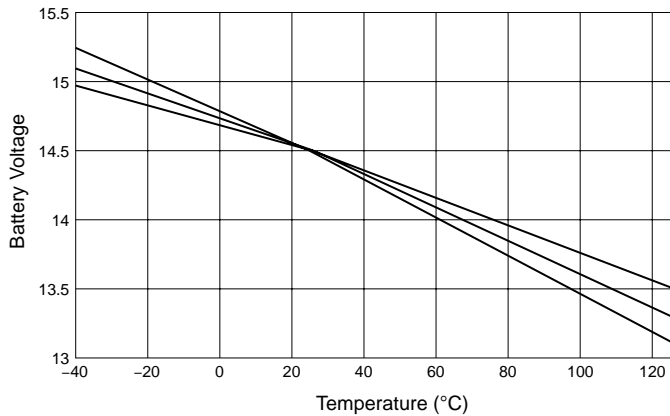

Application Information

The CS3361 is designed for use in an alternator charging system.

In a standard alternator design (Figure 1), the rotor carries the field winding. An alternator rotor usually has several N and S poles. The magnetic field for the rotor is produced by forcing current through a field or rotor winding. The Stator windings are formed into a number of coils spaced around a cylindrical core. The number of coils equals the number of pairs of N and S poles on the rotor. The alternating current in the Stator windings is rectified by the diodes and applied to the regulator. By controlling the amount of field current, the magnetic field strength is controlled and hence the output voltage of the alternator.

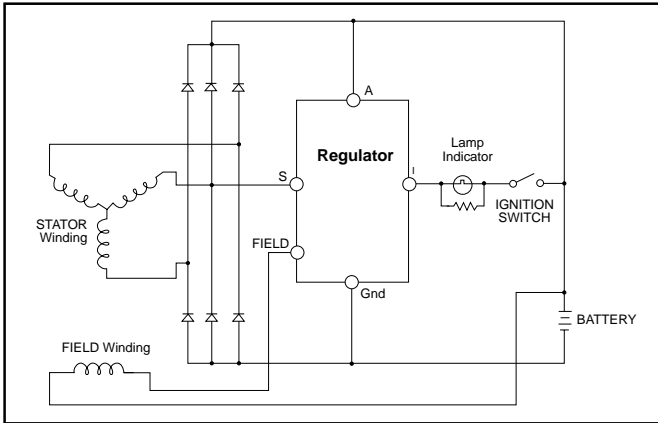

Figure 1. IAR System Block Diagram

Referring to Figure 2, a typical application diagram, the oscillator frequency is set by an external capacitor connected between OSC and ground. The sawtooth waveform ramps between 1V and 3V and provides the timing for the system. For the circuit shown the oscillator frequency is approximately 140Hz. The alternator voltage is sensed at Terminal A via the resistor divider network R1/R2 on the Sense pin of the IC. The voltage at the sense pin determines the duty cycle for the regulator. The voltage is adjusted by potentiometer R2. A relatively low voltage on the sense pin causes a long duty cycle that increases the Field current. A high voltage results in a short duty cycle.

The ignition Terminal (I) switches power to the IC through the V<sub>CC</sub> pin. The Stator pin monitors the voltage from the stator and senses a stopped engine condition. It drives the Lamp pin high after the stator timeout expires. The Lamp pin also goes high when an overvoltage condition is detected on the sense pin. This causes the darlington lamp drive transistor to switch on and pull current through the lamp. If the system voltage continues to increase, the field and lamp output turn off as in an overvoltage or load dump condition.

The SC or Short Circuit pin monitors the field voltage. If the drive output and the SC voltage are simultaneously high for a predetermined period, a short circuit condition is assumed and the output is disabled. The regulator is forced to a minimum short circuit duty cycle.

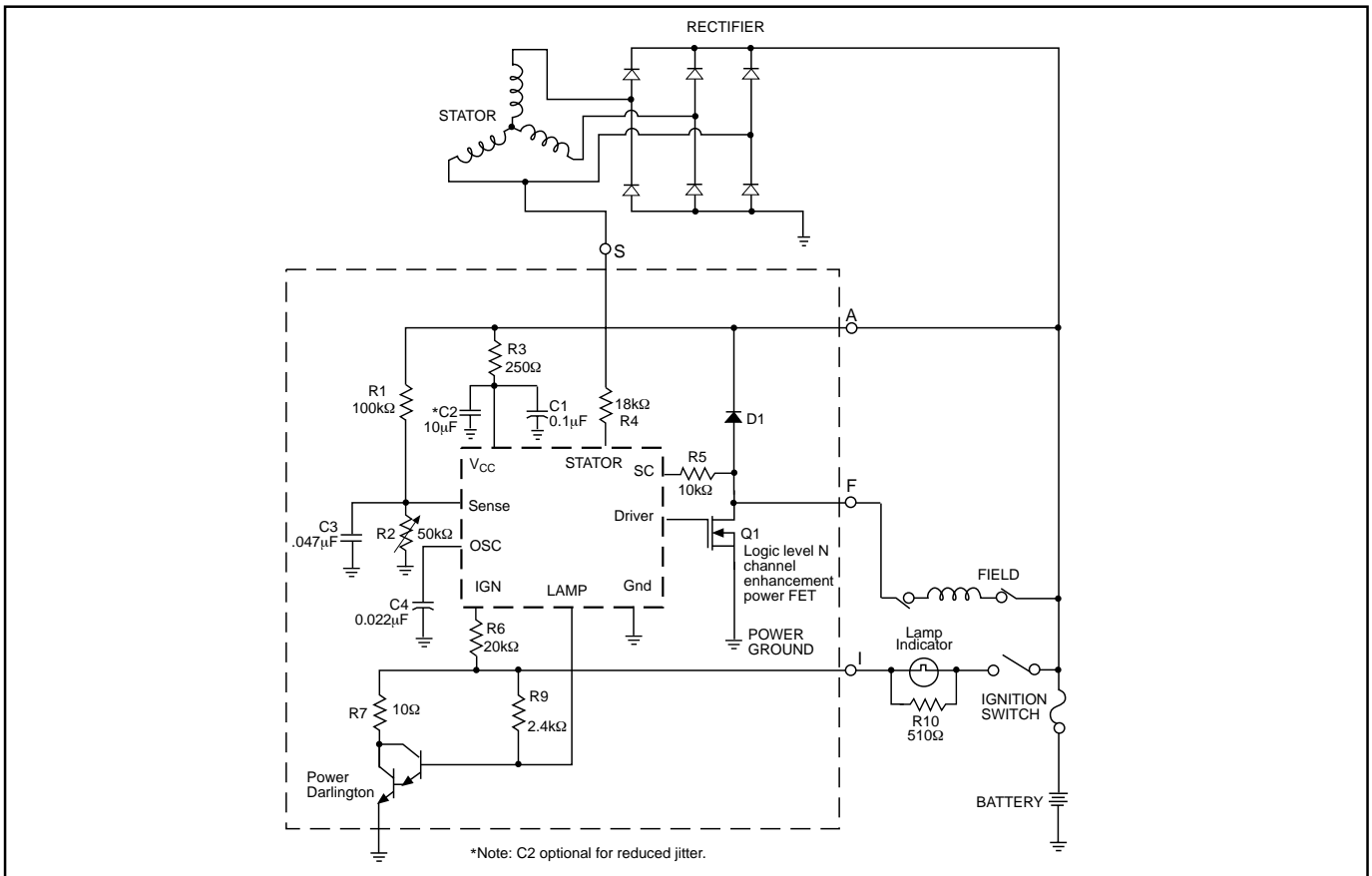

Figure 2. Typical Application Diagram

**Package Specification**

**PACKAGE DIMENSIONS IN mm (INCHES)**

Lead Count	D			
	Metric		English	
	Max	Min	Max	Min
14L SO	8.75	8.55	.344	.337

**PACKAGE THERMAL DATA**

Thermal Data	14L SO		
$R_{\theta JC}$	typ	30	$^{\circ}C/W$
$R_{\theta JA}$	typ	125	$^{\circ}C/W$

**Surface Mount Narrow Body (D); 150 mil wide**

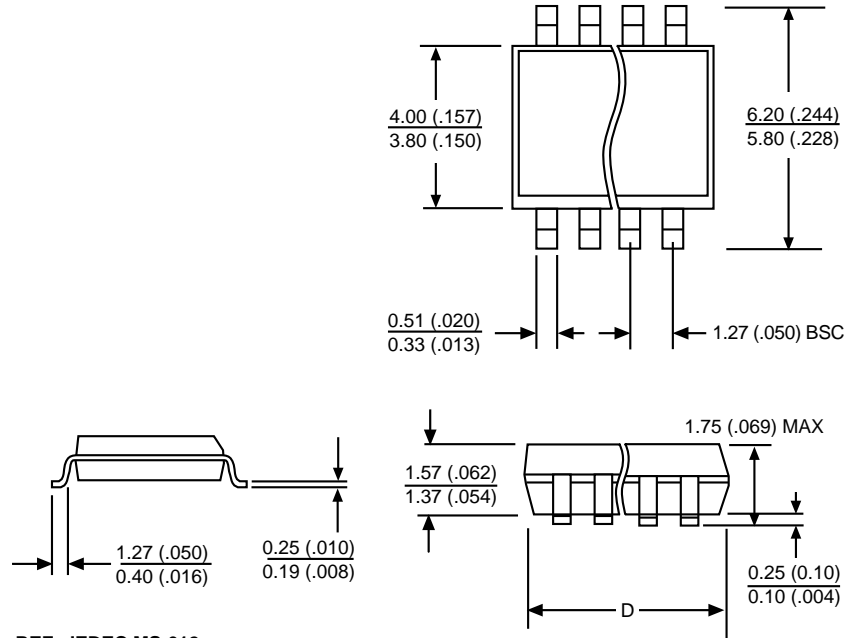

**Ordering Information**

Part Number	Description
CS3361YD14	14L SO
CS3361YDR14	14L SO (tape & reel)

Cherry Semiconductor Corporation reserves the right to make changes to the specifications without notice. Please contact Cherry Semiconductor Corporation for the latest available information.