



1A H-Bridge Stepper Motor Driver

Description

The CS3717A controls and drives one phase of a bipolar stepper motor with chopper control of the phase current. Current levels may be selected in three steps by means of two logic inputs which select one of three current comparators. When both of these inputs are high the device is disabled. A separate logic input controls the direction of current flow. A monostable, programmed by an external RC network, sets the current decay time. The power section is a full H-bridge

driver with four internal clamp diodes for current recirculation. An external connection to the lower emitters is available for the insertion of a sensing resistor. Two CS3717A's and several external components form a complete stepper motor drive subsystem. The recommended operating ambient temperature range is from 0 to 70°C. The CS3717A is supplied in a 16 lead PDIP.

Features

- Full/Half /Quarter Step Operation
- Output Current Up to 1 A
- Motor Supply Voltage 10V to 46V
- Integrated Bootstrap Lowers Saturation Voltage
- Built In Protection Diodes
- Externally Selectable Current Level
- Digital or Analog Control of Output Current Level
- Thermal Overload Protection
- Minimum External Components

Absolute Maximum Ratings

Power Supply Voltage (V_{DDA} , V_{ddb}).....	50V
Logic Supply Voltage (V_{CC}).....	7V
Logic Input Voltage (IN0, IN1, DIRECTION).....	6V
Comparator Input.....	V_{CC}
Reference Input Voltage.....	15V
Output Current (DC Operation).....	1.2A
Storage Temperature	-55°C to +150°C
Operating Junction Temperature.....	-40°C to +150°C
Lead Temperature Soldering	
Wave Solder(through hole styles only)	10 sec. max, 260°C peak

Package Options

16L PDIP

(Internally Fused Leads)

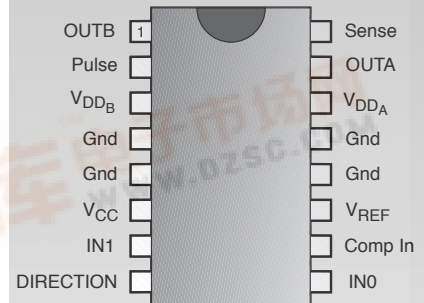

Block Diagram

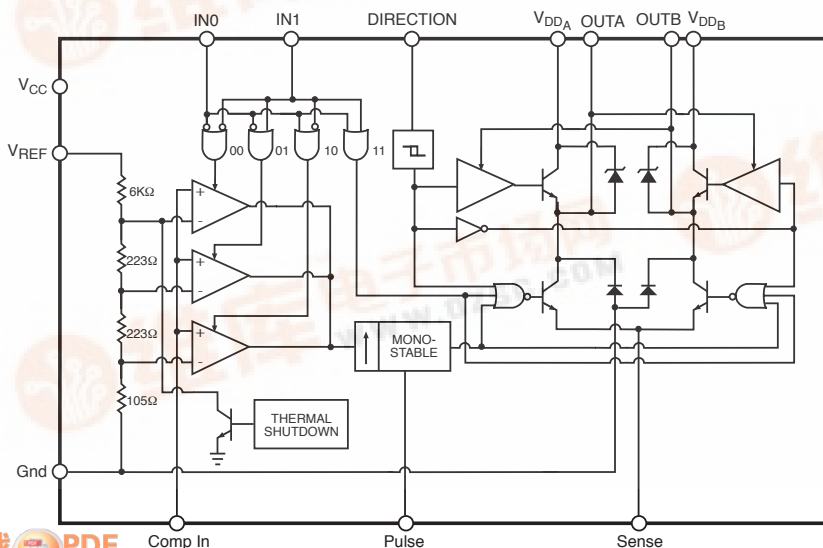

Electrical Characteristics: Refer to the test circuit $V_{DD} = 36V$, $V_{CC} = 5V$, $T_A = 25^\circ C$; unless otherwise specified.

PARAMETER	TEST CONDITIONS	MIN	TYP	MAX	UNIT
Supply Voltage		10		46	V
Logic Supply Voltage		4.75		5.25	V
Logic Supply Current			7	15	mA
Reference Input Current	$V_{REF} = 5V$		0.75	1.00	mA

■ Logic Inputs

Input Low Voltage				0.8	V
Input High Voltage		2			V
Low Voltage Input Current	$V_{IN} = 0.4V$ (DIRECTION) (IN0, IN1)			-100	μA
High Voltage Input Current	$V_{IN} = 2.4V$			10	μA

■ Comparators

Comparator Low Threshold Voltage	$V_{REF} = 5V$ IN0 = Low IN1 = High	66	80	94	mV
Comparator Medium Threshold Voltage	$V_{REF} = 5V$ IN0 = High IN1 = Low	236	251	266	mV
Comparator High Threshold Voltage	$V_{REF} = 5V$ IN0 = Low IN1 = Low	396	416	436	mV
Comparator Input Current				± 20	μA
Cutoff Time	$R_T = 56k\Omega$ $C_T = 820pF$	27		37	μs
Turn Off Delay				2	μs
Output Leakage Current	IN0 = IN1 = High			100	μA

■ Source Diode-Transistor Pair

Saturation Voltage	$I_{MOTOR} = -0.5A$ conduction period recirculation period		1.7	2.1	V
			1.10	1.35	V
Saturation Voltage	$I_{MOTOR} = -1A$ conduction period recirculation period		2.1	2.8	V
			1.7	2.5	V
Leakage Current	$V_S = 46V$			300	μA
Diode Forward Voltage	$I_{MOTOR} = -0.5A$		1.00	1.25	V
	$I_{MOTOR} = -1A$		1.3	1.7	V

■ Sink Diode-Transistor Pair

Saturation Voltage	$I_{MOTOR} = 0.5A$		1.20	1.45	V
	$I_{MOTOR} = 1A$		1.75	2.30	V
Leakage Current	$V_S = 46V$			300	μA
Diode Forward Voltage	$I_{MOTOR} = 0.5A$		1.1	1.5	V
	$I_{MOTOR} = 1A$		1.4	2.0	V

Truth Table

IN0	IN1	Output Current
H	H	No Current
L	H	Low Current
H	L	Medium Current
L	L	High Current

Package Pin Description

PACKAGE PIN #	PIN SYMBOL	FUNCTION
16L (Internally Fused Leads)		
1	OUT B	Output connection with OUTA. The output stage is a “H” bridge formed by four transistors and four diodes suitable for switching applications.
2	Pulse	A parallel RC network connected to this pin sets the OFF time of the lower power transistors. The pulse generator is a monostable triggered by the rising edge of the output of the comparators ($t_{OFF} = 0.69 R_T C_T$).
3	V _{DDB}	Supply voltage input for half output stage.
4, 5, 12, 13	Gnd	Ground connection. Also conducts heat from die to printed circuit copper.
6	V _{CC}	Supply voltage input for logic circuitry.
7	IN1	This pin and IN0 are logic inputs which select the outputs of the three comparators to set the current level. Current also depends on the sensing resistor and reference voltage. See truth table.
8	DIRECTION	This TTL-compatible logic input sets the direction of current flow through the load. A high level causes current to flow from OUTA (source) to OUTB (sink). A Schmitt trigger on this input provides good noise immunity and a delay circuit prevents output stage short circuits during switching.
9	IN0	See IN1.
10	Comp In	Input connected to the three comparators. The voltage across the sense resistor is fed back to this input through the low pass filter $R_C C_C$. The lower power transistors are disabled when the sense voltage exceeds the reference voltage of the selected comparator. When this occurs the current decays for a time set by $R_T C_T$, $t_{OFF} = 0.69 R_T C_T$.
11	V _{REF}	A voltage applied to this pin sets the reference voltage of the three comparators, thus determining the output current (also dependent on R_{Sense} and the two inputs IN 0 and IN 1).
14	V _{DDA}	Supply voltage input for half output stage.
15	OUT A	See OUTB.
16	Sense	Connection to lower emitters of output stage for insertion of current sense resistor.

Typical Performance Characteristics

Source Saturation Voltage vs. Output Current
(Recirculation Period)

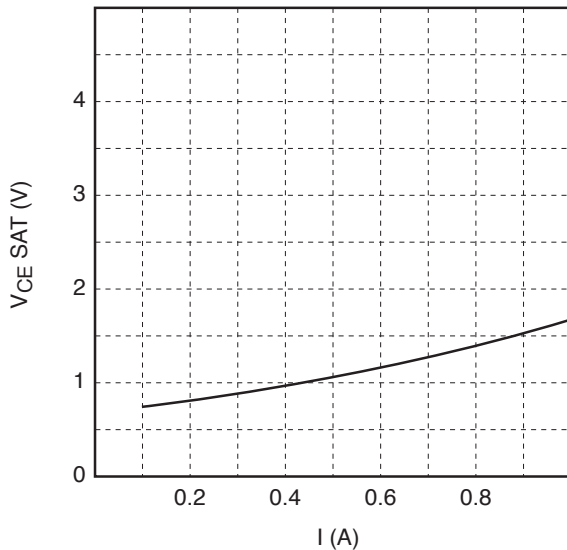

Source Saturation Voltage vs. Output Current
(Conduction Period)

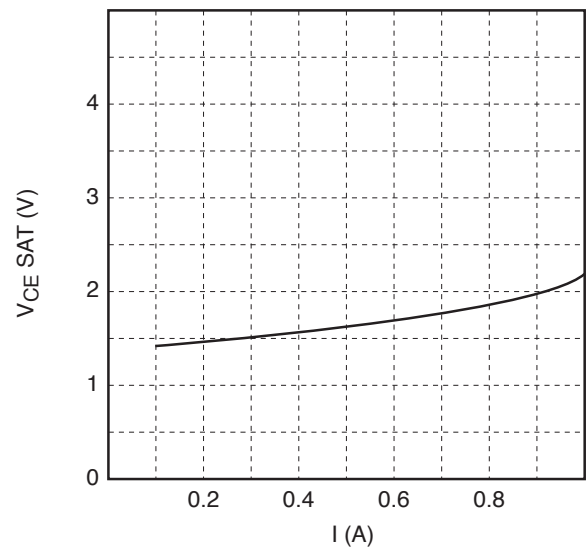

Sink Saturation Voltage vs. Output Current

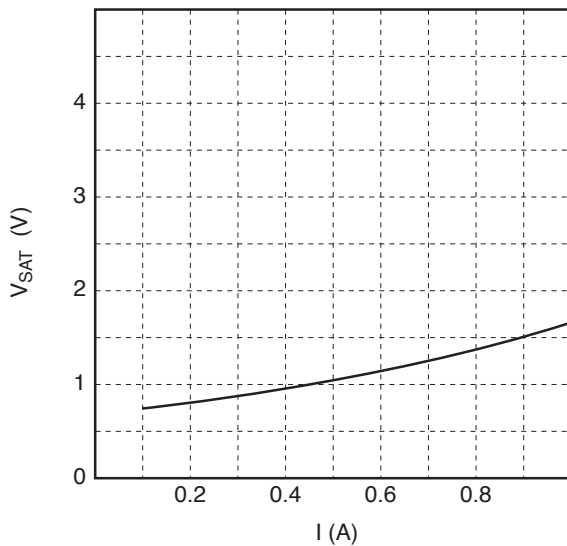

Comparator Threshold vs. Junction Temperature

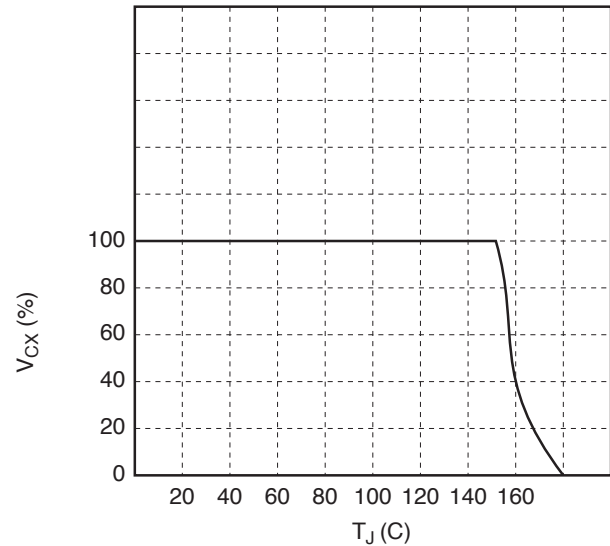

Application Information

The application diagram shows a typical application in which two CS3717A's control a two phase bipolar stepper motor.

Programming

The amplitude of the current flowing in the motor winding is controlled by the logic inputs IN0 and IN1. The truth table (page 3) shows three current levels and an off state. A high level on the "Direction" logic input sets the direction of that current from OUTA to OUTB; a low level from OUTB to OUTA.

It is recommended that unused inputs are tied to V_{CC} or (Gnd) as appropriate to avoid noise problems.

The current levels can be varied continuously by changing V_{REF} .

Control of the motor

The stepper motor can rotate in either direction according to the sequence of the input signals. It is possible to obtain a full step, a half step and quarter step operation.

Full step operation

Both windings of the stepper motor are energized all the time with the same current $I_{MA} = I_{MB}$.

IN0 and IN1 remain fixed at whatever torque value is required.

Calling \bar{A} the condition with winding A energized in one direction and A in the other direction, the sequence for full step rotation is:

$$AB \rightarrow \bar{A}B \rightarrow \bar{A}\bar{B} \rightarrow A\bar{B} \text{ etc.}$$

Application Information: continued

CS3717A

For rotation in the other direction the sequence must be reversed.
The torque of each step is constant in full step operation.

Half step operation

Power is applied alternately to one winding then both according to the sequence:

$$AB \rightarrow B \rightarrow \bar{A}B \rightarrow \bar{A} \rightarrow \bar{A}\bar{B} \rightarrow \bar{B} \rightarrow A\bar{B} \rightarrow A \text{ etc.}$$

Like full step this can be done at any current level; the torque is not constant but is lower when only one winding is energized.

A coil is turned off by setting IN0 and IN1 both high.

Quarter step operation

It is preferable to realize the quarter step operation at full power otherwise the steps will be of very irregular size.

The extra quarter steps are added to the half step sequence by putting one coil on half current according to the sequence.

$$AB \rightarrow \frac{A}{2}B \rightarrow B \rightarrow \frac{\bar{A}}{2}B \rightarrow \bar{A}B \rightarrow \bar{A}\frac{B}{2} \rightarrow \bar{A} \text{ etc.}$$

Motor selection

As the CS3717A provides constant current drive with a switching operation, care must be taken to select stepper motors with low hysteresis losses to prevent motor overheating.

L-C filter

To reduce EMI and chopping losses in the motor, a low pass L-C filter can be inserted across the outputs of the CS3717A as shown in the following diagram.

Input and Output Sequences for Half Step and Full Step Operation

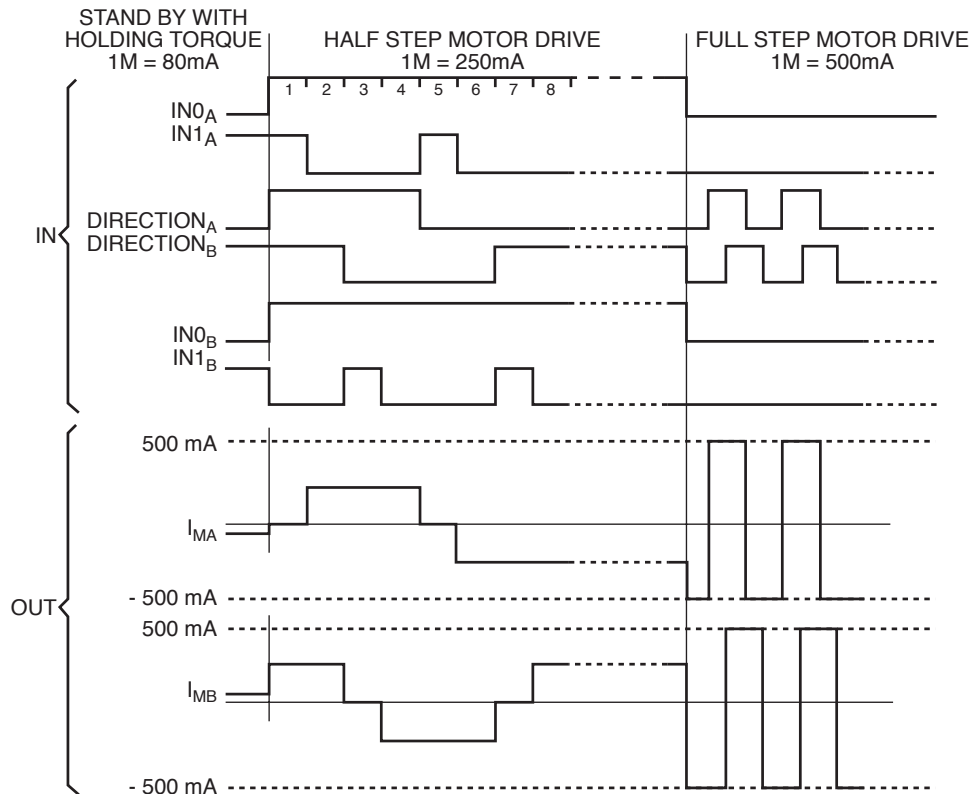
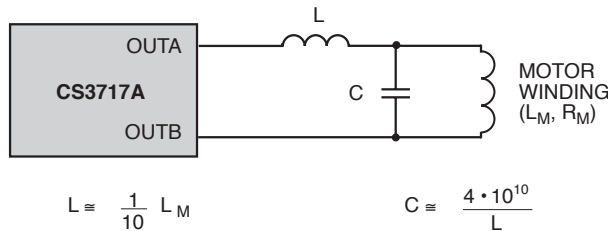

Test Circuit

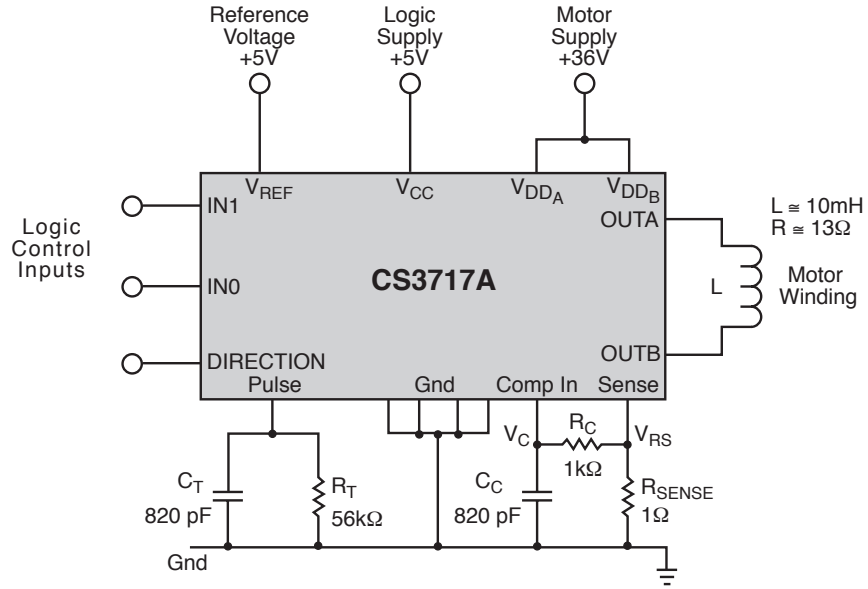

Waveforms with MA Regulating (Phase = 0)

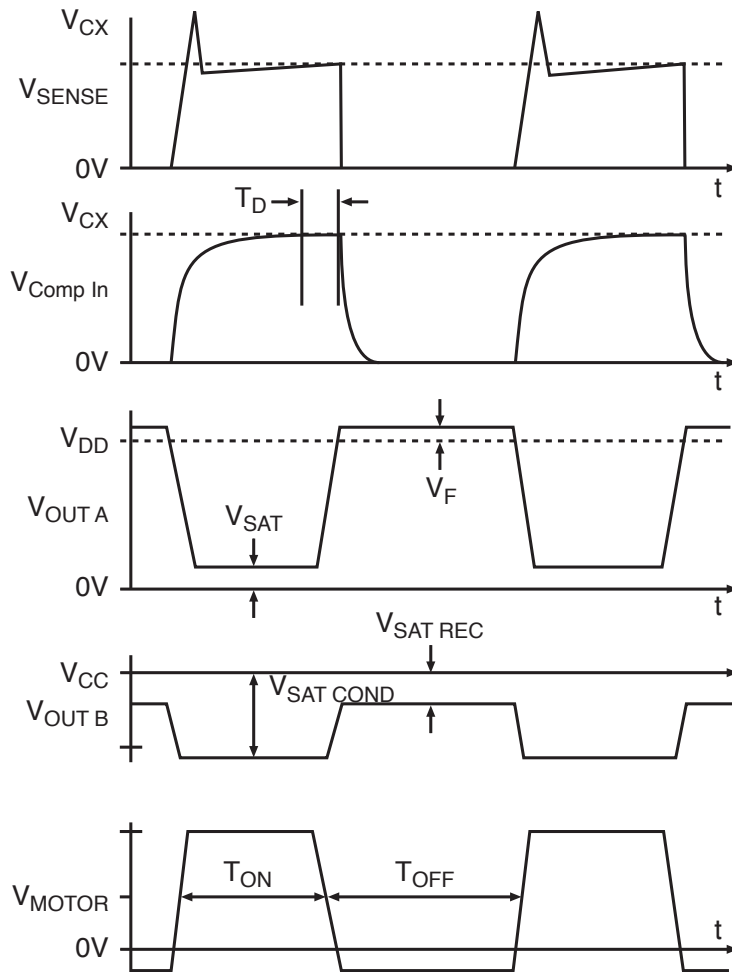

Application Circuit - Two Phase Bipolar Stepper Motor Driver

CS3717A

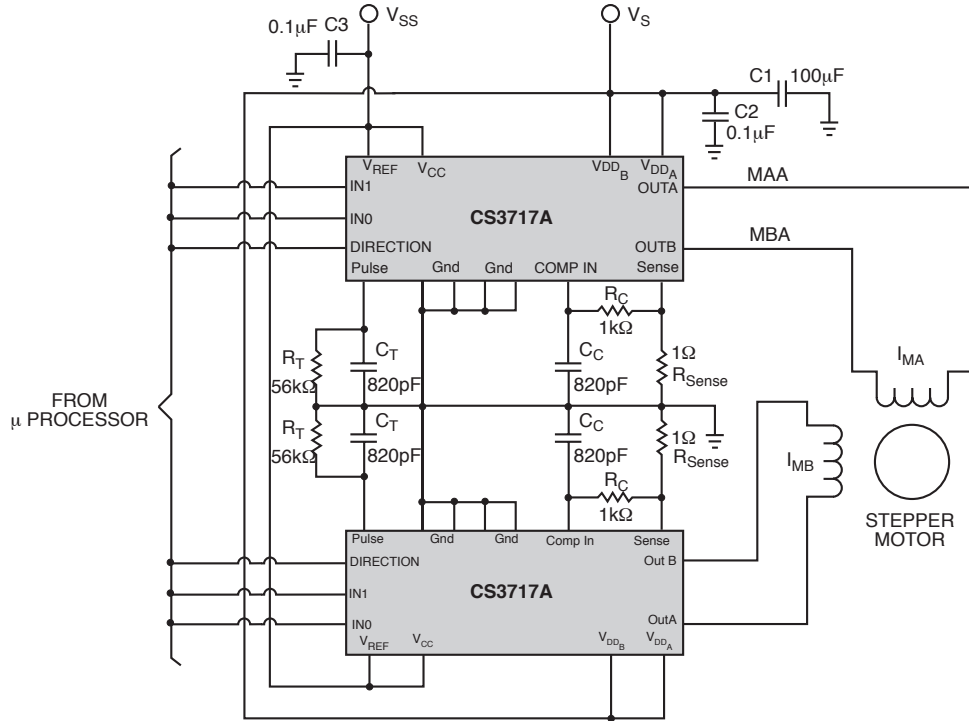

Mounting Instructions

The $R_{\theta JA}$ of the CS3717A can be reduced by soldering the Gnd pins to a suitable copper area of the printed circuit board or to an external heatsink.

The diagram of fig. 2 shows the maximum dissipated power P_{tot} and the $R_{\theta JA}$ as a function of the side "l" of two equal square copper areas having a thickness of 35µ

(see fig. 1). In addition, it is possible to use an external heatsink (see fig. 3). During soldering the pins temperature must not exceed 260°C and the soldering time must not be longer than 12 seconds.

The external heatsink or printed circuit copper area must be connected to electrical ground.

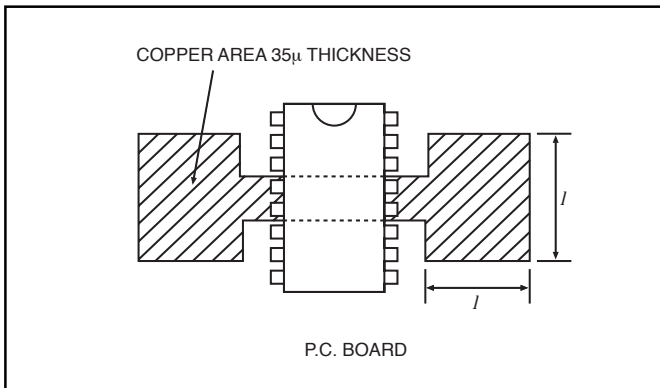

Figure 1 - Example of P.C. Board Copper Area Which is Used as Heatsink with 16 lead fused package.

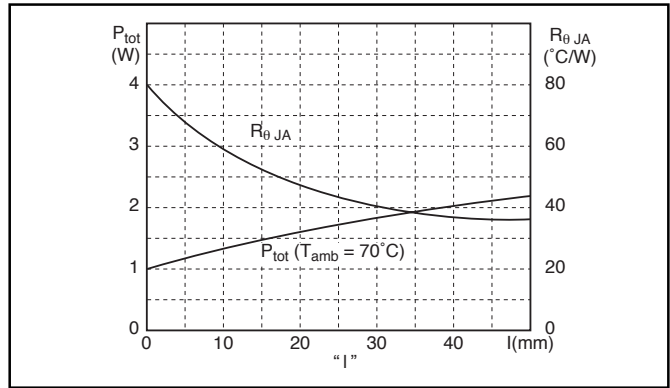

Figure 2 - Max. Power Dissipation And Junction To Ambient Thermal Resistance vs. Size "l" for 16 lead fused package.

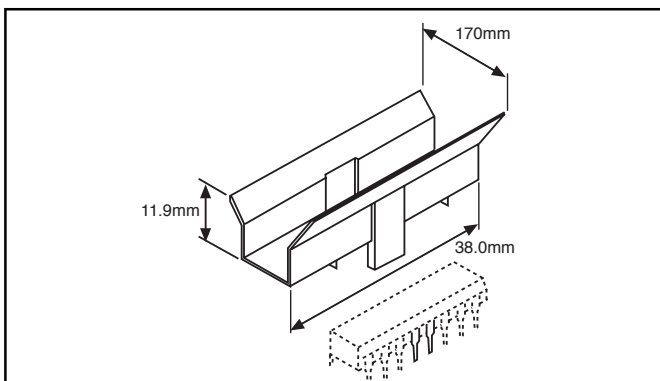

Figure 3 - External Heatsink Mounting Example ($R_{th} = 30^\circ C/W$) for 16 lead fused package.

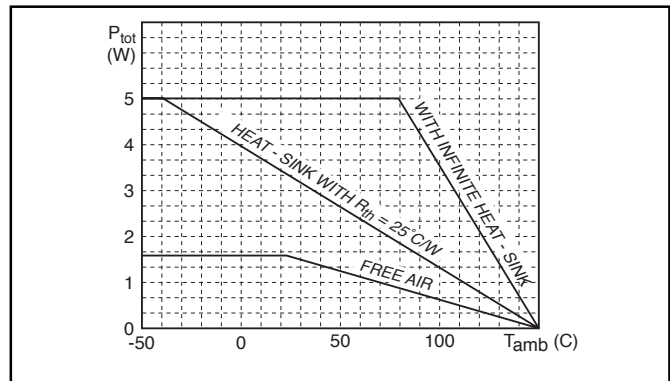

Figure 4 - Maximum Allowable Power Dissipation vs. Ambient Temperature for 16 lead fused package.

Package Specification

PACKAGE DIMENSIONS IN mm (INCHES)

Lead Count	D			
	Metric		English	
	Max	Min	Max	Min
16L PDIP <i>(Internally Fused Leads)</i>	19.69	18.67	.775	.735

PACKAGE THERMAL DATA

Thermal Data		16 Lead PDIP <i>(Internally Fused Leads)</i>	
R _{θJC}	typ	15	°C/W
R _{θJA}	typ	50	°C/W

Plastic DIP (N); 300 mil wide

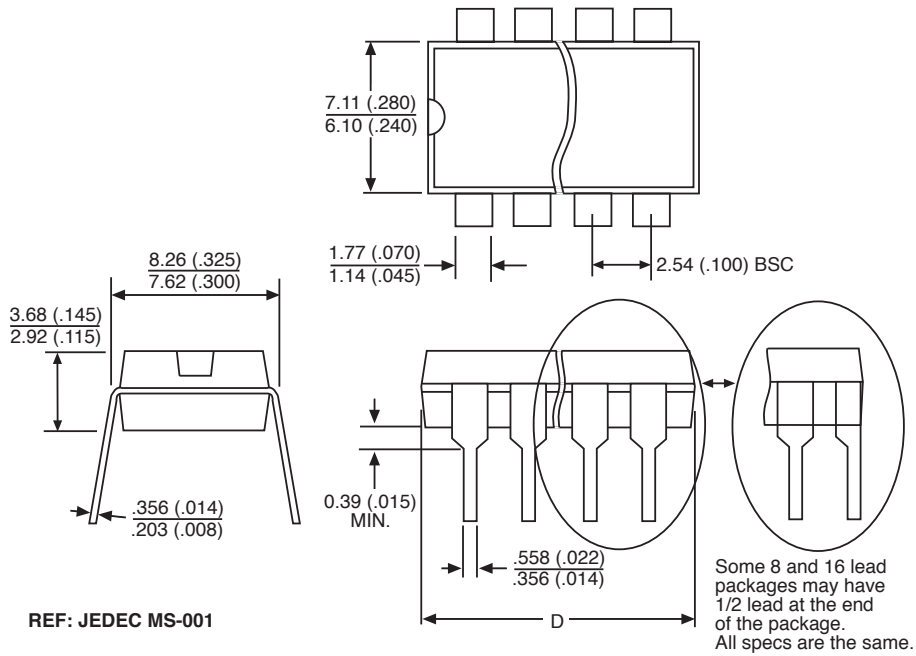

Ordering Information

Part Number	Description
CS3717AGNF16	16 Lead PDIP <i>(Internally Fused Leads)</i>

Cherry Semiconductor Corporation reserves the right to make changes to the specifications without notice. Please contact Cherry Semiconductor Corporation for the latest available information.