



# 7A, 3.3V Fixed Linear Regulator

## Description

The CS5207-3 linear regulator provides 7A at 3.3V with an accuracy of  $\pm 2\%$ .

The regulator is intended for use as post regulator and microprocessor supply. The fast loop response and low dropout voltage make this regulator ideal for applications where low voltage operation and good transient response are important.

The circuit is designed to operate with dropout voltages as low as 1V

depending on the output current level. The maximum quiescent current is only 10mA at full load.

The regulator is fully protected against overload conditions with protection circuitry for Safe Operating Area (SOA), overcurrent and thermal shutdown.

The CS5207-3 is available in 3 lead D<sup>2</sup>PAK and TO-220 packages.

## Features

- Output Current to 7A
- Output Voltage Trimmed to  $\pm 2\%$
- Dropout Voltage 1.4V @ 7A
- Fast Transient Response
- Fault Protection Circuitry
  - Thermal Shutdown
  - Overcurrent Protection
  - Safe Area Protection

## Absolute Maximum Ratings

Supply Voltage, $V_{CC}$ .....	17V
Operating Temperature Range .....	-40°C to 70°C
Junction Temperature .....	150°C
Storage Temperature Range .....	-60°C to 150°C
Lead Temperature Soldering	
Wave Solder (through hole styles only) .....	10 sec. max, 260°C peak
Reflow (SMD styles only) .....	60 sec. max above 183°C, 230°C peak

## Block Diagram

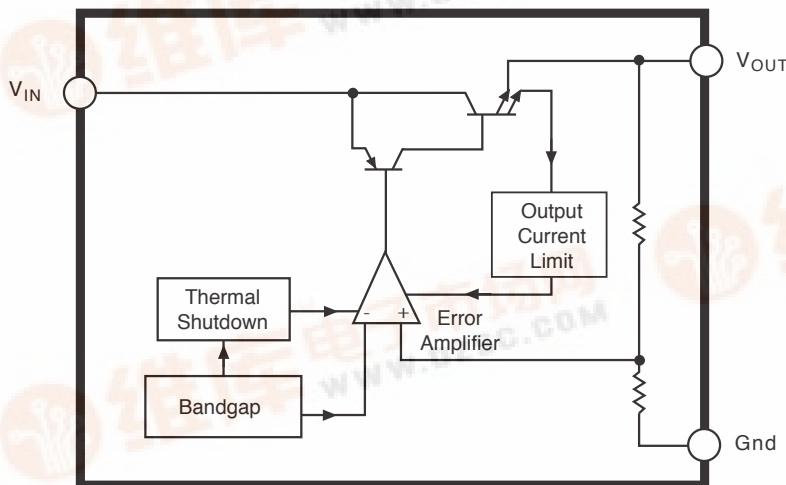

## Package Options

3L TO-220  
Tab ( $V_{OUT}$ )

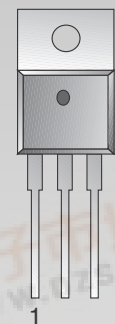

- 1 Gnd
- 2  $V_{OUT}$  (Tab)
- 3  $V_{IN}$

3L D<sup>2</sup>PAK  
Tab ( $V_{OUT}$ )

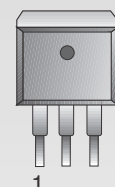

- 1 Gnd
- 2  $V_{OUT}$  (Tab)
- 3  $V_{IN}$

**Electrical Characteristics:**  $C_{IN} = 10\mu\text{F}$ ,  $C_{OUT} = 22\mu\text{F}$  Tantalum,  $V_{IN} - V_{OUT} = 3\text{V}$ ,  $V_{IN} \leq 15\text{V}$ ,  $0^\circ\text{C} \leq T_A \leq 70^\circ\text{C}$ ,  $T_J \leq +150^\circ\text{C}$ , unless otherwise specified,  $I_{full\ load} = 7\text{A}$ .

PARAMETER	TEST CONDITIONS	MIN	TYP	MAX	UNIT
<b>■ 3.3V Fixed Output Voltage</b>					
CS5207-3 (Notes 1 and 2)	$V_{IN} - V_{OUT} = 1.6\text{V}$ ; $10\text{mA} \leq I_{OUT} \leq 7\text{A}$	3.234 (-2%)	3.300	3.366 (+2%)	V
Line Regulation	$1.6\text{V} \leq V_{IN} - V_{OUT} \leq 6\text{V}$ ; $I_{OUT} = 10\text{mA}$		0.04	0.20	%
Load Regulation (Notes 1 and 2)	$V_{IN} - V_{OUT} = 1.6\text{V}$ ; $10\text{mA} \leq I_{OUT} \leq 7\text{A}$		0.13	0.5	%
Dropout Voltage (Note 3)	$I_{OUT} = 7\text{A}$		1.4	1.55	V
Current Limit	$V_{IN} - V_{OUT} = 3\text{V}$ ; $T_J \geq 25^\circ\text{C}$ $V_{IN} - V_{OUT} = 9\text{V}$	7.1	8.5 1.0		A A
Quiescent Current	$V_{IN} \leq 9\text{V}$ ; $I_{OUT} = 10\text{mA}$		5.0	10.0	mA
Thermal Regulation	30ms pulse; $T_A = 25^\circ\text{C}$		0.003		%W
Ripple Rejection	$f = 120\text{Hz}$ ; $I_{OUT} = 7\text{A}$		80		dB
Temperature Stability			0.5		%
RMS Output Noise	$10\text{Hz} \leq f \leq 10\text{kHz}$ ; $T_A = 25^\circ\text{C}$		0.003		% $V_{OUT}$
Thermal Shutdown		150	180		$^\circ\text{C}$
Thermal Shutdown Hysteresis			25		$^\circ\text{C}$

Note 1: Load regulation and output voltage are measured at a constant junction temperature by low duty cycle pulse testing. Changes in output voltage due to thermal gradients or temperature changes must be taken into account separately.

Note 2: Specifications apply for an external Kelvin sense connection at a point on the output pin 1/4" from the bottom of the package.

Note 3: Dropout voltage is a measurement of the minimum input/output differential at full load.

### Package Pin Description

PACKAGE PIN #	PIN SYMBOL	FUNCTION
<b>3L TO-220 &amp; 3L D<sup>2</sup>PAK</b>		
1	Gnd	Ground connection.
2	$V_{OUT}$	Regulated output voltage (case).
3	$V_{IN}$	Input voltage.

### Typical Performance Characteristics

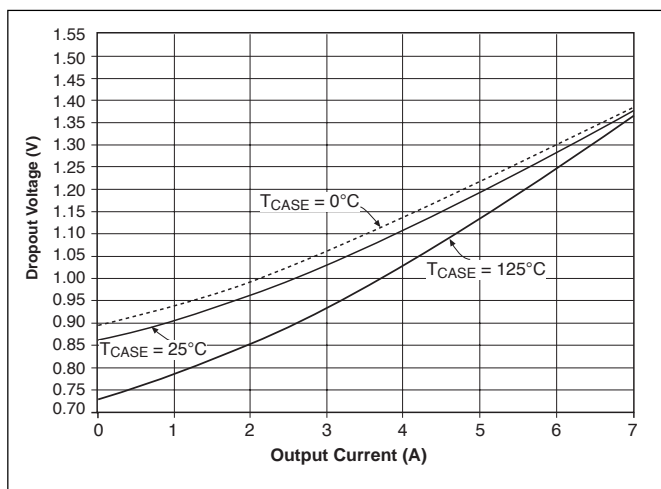

Dropout Voltage vs. Output Current

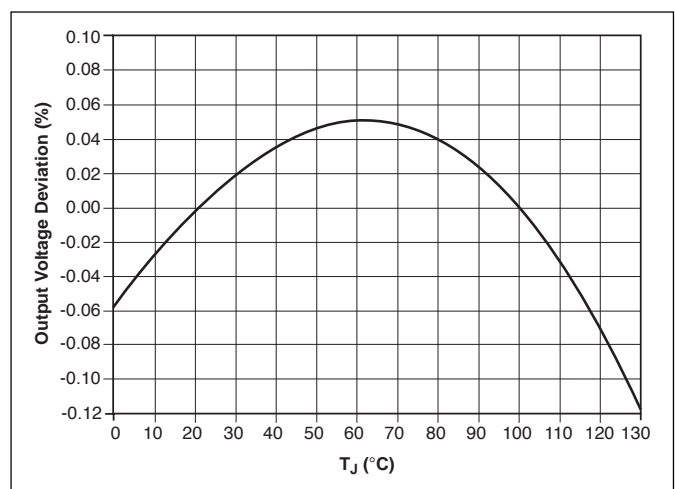

Output Voltage vs. Temperature

## Typical Performance Characteristics: continued

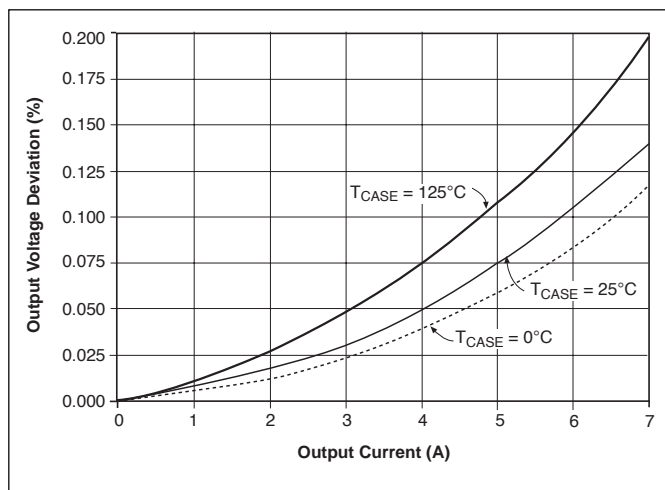

Load Regulation vs. Output Current

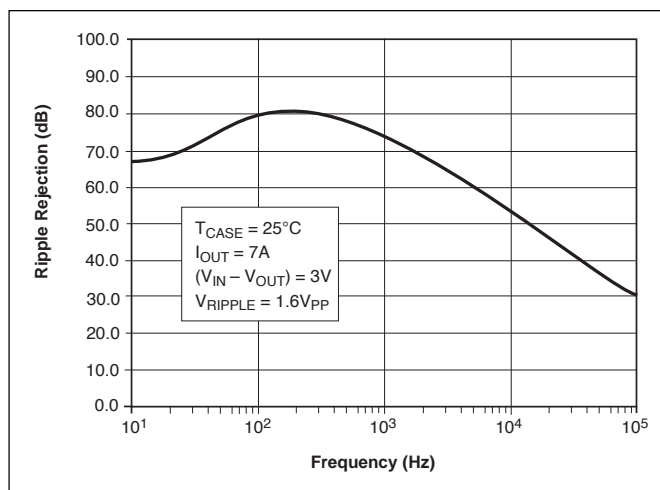

Ripple Rejection vs. Frequency

## Applications Information

The CS5207-3 linear regulator provides a fixed 3.3V output at currents up to 7A. The regulator is protected against short circuit, and includes thermal shutdown and safe area protection (SOA) circuitry. The SOA protection circuitry decreases the maximum available output current as the input-output differential voltage increases.

The CS5207-3 has a composite PNP-NPN output transistor and requires an output capacitor for stability. A detailed procedure for selecting this capacitor is included in the Stability Considerations section.

### Stability Considerations

The output or compensation capacitor helps determine three main characteristics of a linear regulator: start-up delay, load transient response and loop stability.

The capacitor value and type is based on cost, availability, size and temperature constraints. A tantalum or aluminum electrolytic capacitor is best, since a film or ceramic capacitor with almost zero ESR can cause instability. The aluminum electrolytic capacitor is the least expensive solution. However, when the circuit operates at low temperatures, both the value and ESR of the capacitor will vary considerably. The capacitor manufacturers' data sheet provides this information.

A 22 $\mu$ F tantalum capacitor will work for most applications, but with high current regulators such as the CS5207-3 the transient response and stability improve with higher values of capacitor. The majority of applications for this regulator involve large changes in load current so the output capacitor must supply the instantaneous load current. The ESR of the output capacitor causes an immediate drop in output voltage given by:

$$\Delta V = \Delta I \times \text{ESR}$$

For microprocessor applications it is customary to use an output capacitor network consisting of several tantalum and ceramic capacitors in parallel. This reduces the overall ESR and reduces the instantaneous output voltage drop under load transient conditions. The output capacitor net-

work should be as close as possible to the load for the best results.

### Protection Diodes

When large external capacitors are used with a linear regulator it is sometimes necessary to add protection diodes. If the input voltage of the regulator gets shorted, the output capacitor will discharge into the output of the regulator. The discharge current depends on the value of the capacitor, the output voltage and the rate at which  $V_{IN}$  drops. In the CS5207-3 regulator, the discharge path is through a large junction and protection diodes are not usually needed. If the regulator is used with large values of output capacitance and the input voltage is instantaneously shorted to ground, damage can occur. In this case, a diode connected as shown in Figure 1 is recommended.

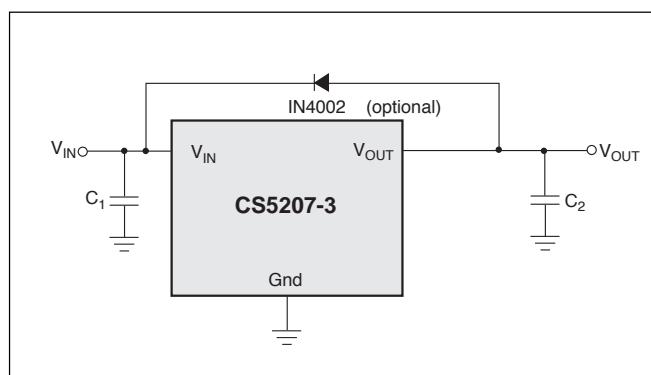

Figure 1. Protection diode scheme for fixed output regulator.

### Output Voltage Sensing

Since the CS5207-3 is a three terminal regulator, it is not possible to provide true remote load sensing. Load regulation is limited by the resistance of the conductors connecting the regulator to the load.

Best load regulation occurs when the regulator is connected to the load as shown in Figure 2.

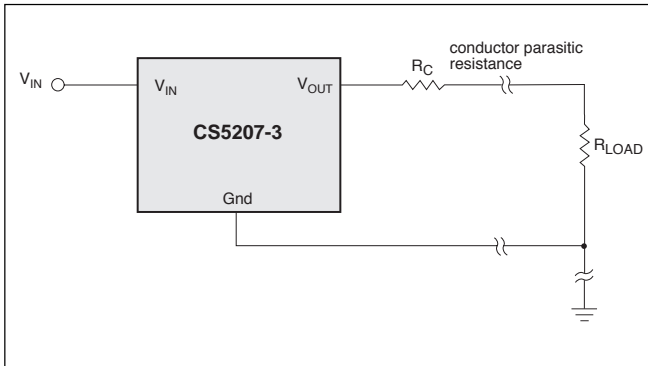

Figure 2. Grounding scheme for the output regulator to minimize parasitics.

### Calculating Power Dissipation and Heat Sink Requirements

The CS5207-3 linear regulator includes thermal shutdown and safe operating area circuitry to protect the device. High power regulators such as this usually operate at high junction temperatures so it is important to calculate the power dissipation and junction temperatures accurately to ensure that an adequate heat sink is used.

The case is connected to  $V_{OUT}$  on the CS5207-3, and electrical isolation may be required for some applications. Thermal compound should always be used with high current regulators such as these.

The thermal characteristics of an IC depend on the following four factors:

1. Maximum Ambient Temperature  $T_A$  ( $^{\circ}\text{C}$ )
2. Power dissipation  $P_D$  (Watts)
3. Maximum junction temperature  $T_J$  ( $^{\circ}\text{C}$ )
4. Thermal resistance junction to ambient  $R_{\theta JA}$  ( $\text{C}/\text{W}$ )

These four are related by the equation

$$T_J = T_A + P_D \times R_{\theta JA} \quad (1)$$

The maximum ambient temperature and the power dissipation are determined by the design while the maximum junction temperature and the thermal resistance depend on the manufacturer and the package type.

The maximum power dissipation for a regulator is:

$$P_{D(\max)} = \{V_{IN(\max)} - V_{OUT(\min)}\} I_{OUT(\max)} + V_{IN(\max)} I_Q \quad (2)$$

where

$V_{IN(\max)}$  is the maximum input voltage,

$V_{OUT(\min)}$  is the minimum output voltage,

$I_{OUT(\max)}$  is the maximum output current, for the application

$I_Q$  is the maximum quiescent current at  $I_{OUT(\max)}$ .

A heat sink effectively increases the surface area of the package to improve the flow of heat away from the IC and into the surrounding air.

Each material in the heat flow path between the IC and the outside environment has a thermal resistance. Like series electrical resistances, these resistances are summed to

determine  $R_{\theta JA}$ , the total thermal resistance between the junction and the surrounding air.

1. Thermal Resistance of the junction to case,  $R_{\theta JC}$  ( $^{\circ}\text{C}/\text{W}$ )
2. Thermal Resistance of the case to Heat Sink,  $R_{\theta CS}$  ( $^{\circ}\text{C}/\text{W}$ )
3. Thermal Resistance of the Heat Sink to the ambient air,  $R_{\theta SA}$  ( $^{\circ}\text{C}/\text{W}$ )

These are connected by the equation:

$$R_{\theta JA} = R_{\theta JC} + R_{\theta CS} + R_{\theta SA} \quad (3)$$

The value for  $R_{\theta JA}$  is calculated using equation (3) and the result can be substituted in equation (1).

$R_{\theta JC}$  is  $1.6^{\circ}\text{C}/\text{Watt}$  for the CS5207-3. For a high current regulator such as the CS5207-3, the majority of the heat is generated in the power transistor section. The value for  $R_{\theta SA}$  depends on the heat sink type, while  $R_{\theta CS}$  depends on factors such as package type, heat sink interface (is an insulator and thermal grease used?), and the contact area between the heat sink and the package. Once these calculations are complete, the maximum permissible value of  $R_{\theta JA}$  can be calculated and the proper heat sink selected. For further discussion on heat sink selection, see application note "Thermal Management for Linear Regulators."

## Package Specification

CS5207-3

### PACKAGE DIMENSIONS IN mm (INCHES)

#### 3 Lead D<sup>2</sup>PAK (DP)

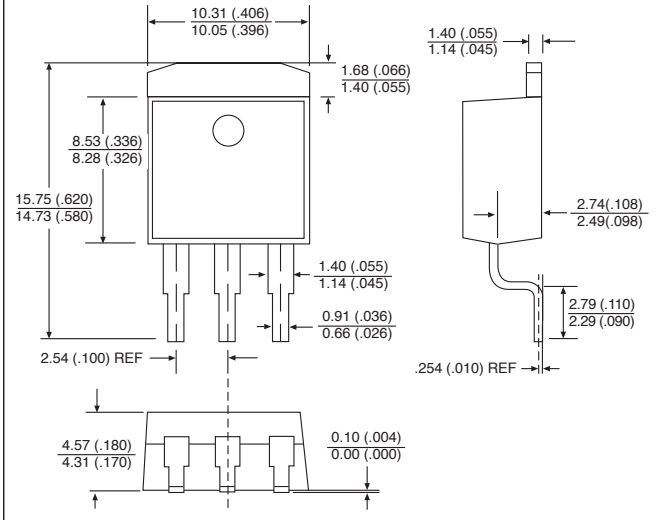

### PACKAGE THERMAL DATA

Thermal Data		3L TO-220	3L D <sup>2</sup> PAK	
R <sub>θJC</sub>	typ	1.6	1.6	°C/W
R <sub>θJA</sub>	typ	50	10 - 50*	°C/W

\*Depending on thermal properties of substrate. R<sub>θJA</sub> = R<sub>θJC</sub> + R<sub>θCA</sub>

#### 3 Lead TO-220 (T) Straight

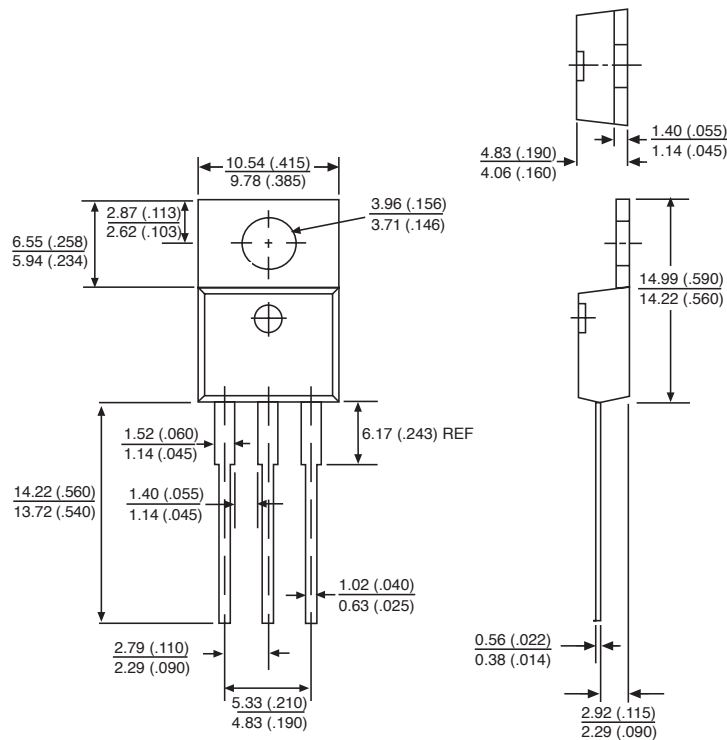

### Ordering Information

Part Number	Description
CS5207-3GT3	3L TO-220 Straight
CS5207-3GDP3	3L D <sup>2</sup> PAK
CS5207-3GDPR3	3L D <sup>2</sup> PAK (tape & reel)

Cherry Semiconductor Corporation reserves the right to make changes to the specifications without notice. Please contact Cherry Semiconductor Corporation for the latest available information.