



T1/E1 Universal Line Interface

Features

- Provides T1 and E1, Long Haul and Short Haul Line Interface
- Provides a QRSS Test Signal and Error Detector
- Impedance Matching Line Driver Using a Single Transformer
- Greater than 14 dB of Transmit Return Loss Without Using External Resistors
- No Crystal Needed for Jitter Attenuation
- Meets AT&T 62411 and TBR 12/13 Jitter Tolerance and Attenuation Requirements
- Meets ANSI T1.231B and ITU-T G.775 Requirements for LOS and AIS
- Meets the BS6450 Transmitter Short-Circuit Requirements for E1 Applications
- Compliant with:
 - ITU-T Recommendations: G.703, G.732, G.775 and I.431
 - American National Standards (ANSI): T1.102, T1.105, T1.403, T1.408, and T1.231

- FCC Rules and Regulations: Part 68 and Part 15
- AT&T Publication 62411
- ETSI ETS 300 011, 300 233, TBR 12/13
- TR-NET-00499

Description

The CS61581 is a primary rate line interface unit capable of operation in both short haul (intraoffice) and long haul applications. The CS61581 combines the complete analog transmit and receive circuitry for a single, full-duplex interface at T1 and E1 rates. The device is pin and function compatible with the Level One LXT310 and LXT318 (the latter in the host mode only). The device can also replace LXT359 and LXT360. Enhanced functionality is available through an extended register set allowing short haul operation, custom pulse shape generation, QRSS pattern generation, detection and error counting, and generation and detection of loop up and loop down codes. The CS61581 features Crystal[®] low-power impedance-matched line drivers and crystal-less jitter attenuation.

ORDERING INFORMATION

CS61581-IL 28-pin PLCC

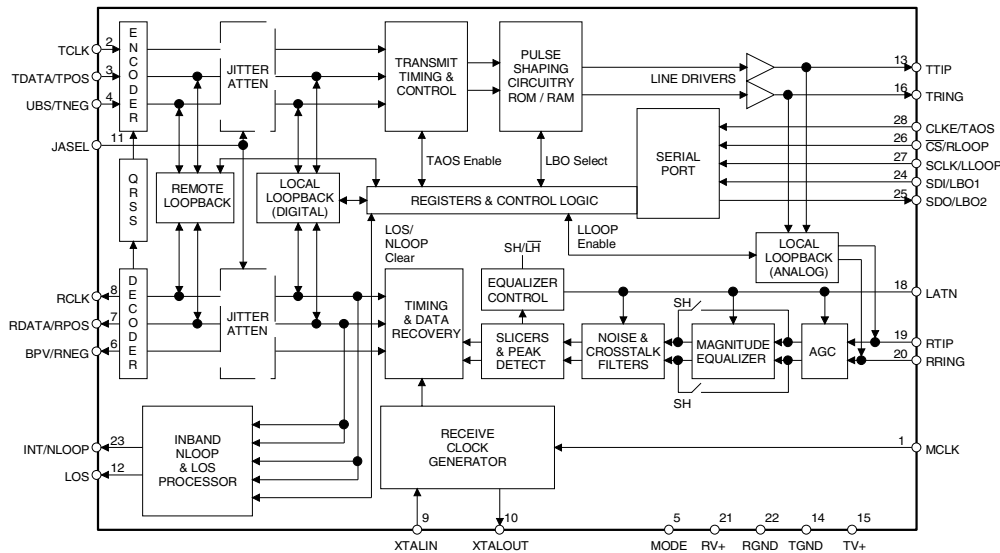

TABLE OF CONTENTS

1. CHARACTERISTICS AND SPECIFICATIONS	4
ABSOLUTE MAXIMUM RATINGS	4
RECOMMENDED OPERATING CONDITIONS	4
DIGITAL CHARACTERISTICS	4
ANALOG SPECIFICATIONS	5
T1 SWITCHING CHARACTERISTICS	7
E1 SWITCHING CHARACTERISTICS	7
SWITCHING CHARACTERISTICS	9
2. THEORY OF OPERATION	10
2.1 Operating Mode Selection	10
2.2 Master Clocks	10
2.3 Transmitter	10
2.4 Transmit All Ones Select	12
2.4.1 Receiver	13
2.4.2 Short Haul	13
2.4.3 Long Haul	13
2.4.4 Clock Recovery	13
2.4.5 Jitter Tolerance	14
2.5 Receiver Line Attenuation Indication	14
2.6 Jitter Attenuator	14
2.7 Receiver Loss of Signal	14
2.8 Local Loopback	15
2.9 Remote Loopback	16
2.10 Network Loopback	16
2.11 Alarm Indication Signal	16
2.12 Serial Interface	16
2.21 Interrupts	23
3. QRSS TEST MODE	23
4. ARBITRARY WAVEFORM GENERATION	24
4.1 Power On Reset / Reset	25
4.2 Power Supply	26
6. PIN DESCRIPTION	31
6.1 Power Supplies	32
6.2 Oscillator	32
6.3 Control	32
6.4 Status	33
6.5 Serial Control Interface	33
6.6 Data Input/Output	34
7. PACKAGE DIMENSIONS	36

LIST OF FIGURES

Figure 1. Signal Rise and Fall Characteristics	8
Figure 2. Recovered Clock and Data Switching Characteristics.....	8
Figure 3. Transmit Clock and Data Switching Characteristics	8
Figure 4. Serial Port Write Timing Diagram	9
Figure 5. Serial Port Read Timing Diagram	9
Figure 6. Typical Pulse Shape at DSX-1 Cross Connect.....	12
Figure 7. Mask of the Pulse at the 2048 kbps Interface.....	12
Figure 8. Minimum Input Jitter Tolerance of Receiver	13
Figure 9. LATN Pulse Width encoding	14
Figure 10. Typical Jitter Transfer Function - T1	15
Figure 11. Typical Jitter Transfer Function - E1	15
Figure 12. Input/Output Timing (showing address 0x10)	17
Figure 13. Phase Definition of Arbitrary Waveforms	24
Figure 14. Example of Summing of Waveforms.....	25
Figure 15. Matched Impedance Output Configuration	28
Figure 16. Low Impedance Output Configuration	29
Figure 17. Typical System Connection	30

LIST OF TABLES

Table 1. Pulse Shape Selection and Transformer Requirements	11
Table 2. Data Output/Clock Relationship	13
Table 3. Register Map.....	17
Table 4. Register 0x10 Decoding.....	23
Table 5. Register 0x10 Decoding.....	23
Table 5. Diagnostic Mode Availability	26
Table 6. Transformer Specification	26
Table 7. Recommended Transformers for the CS61581	27

1. CHARACTERISTICS AND SPECIFICATIONS

ABSOLUTE MAXIMUM RATINGS

Parameter	Symbol	Min	Max	Units
DC Supply (referenced to RGND=TGND=0 V)	RV+	-	6.0	V
	TV+	-	(RV+) + 0.3	V
Input Voltage, Any Pin	V _{in}	RGND-0.3	(RV+) + 0.3	V
Input Current, Any Pin (Note 1)	I _{in}	-10	10	mA
Ambient Operating Temperature	T _A	-40	85	°C
Storage Temperature	T _{stg}	-65	150	°C

WARNING: Operations at or beyond these limits may result in permanent damage to the device. Normal operation is not guaranteed at these extremes

Notes: 1 Transient currents of up to 100 mA will not cause SCR latch-up. Also TTIP, TRING, TV+ and TGND can withstand a continuous current of 100 mA.

RECOMMENDED OPERATING CONDITIONS

Parameter	Symbol	Min	Typ	Max	Units
DC Supply (Note 1)	RV+, TV+	4.75	5.0	5.25	V
Ambient Operating Temperature	T _A	-40	25	85	°C
Power Consumption, Long Haul (Notes 2,3,4)	P _C	Low Z	390	630	mW
		Match Z	400	575	
Power Consumption, Short Haul (Notes 2,3,4)	P _C	Low Z	480	725	mW
		Match Z	430	650	

- Notes: 1. TV+ must not exceed RV+ by more than 0.3 V.
2. Power consumption while driving line load over operating temperature range. Includes IC and load. Digital input levels are within 10% of the supply rails and digital outputs are driving a 50 pF capacitive load.
3. Typical consumption corresponds to 50% ones density and medium line length at 5.0 V.
4. Maximum consumption corresponds to 100% ones density and maximum line length at 5.25 V.

DIGITAL CHARACTERISTICS (T_A = -40°C to 85°C; TV+, RV+ = 5.0 V ±5%; GND = 0 V)

Parameter	Symbol	Min	Typ	Max	Units
High-Level Input Voltage (Note 5) PINS 1-4, 24-28	V _{IH}	2.0	-	-	V
Low-Level Input Voltage (Note 5) PINS 1-4, 24-28	V _{IL}	-	-	0.8	V
High-Level Output Voltage (Notes 5, 6) I _{OUT} = -40 ∞A PINS 6-8, 25	V _{OH}	2.4	-	-	V
Low-Level Output Voltage (Notes 5, 6) I _{OUT} = 1.6 mA PINS 6-8, 25	V _{OL}	-	-	0.4	V
Input Leakage Current		-	-	±10	∞A

Notes: 5. This specification guarantees TTL compatibility (V_{OH} = 2.4 V @ I_{OUT} = -40 ∞A).

6. Output drivers are TTL compatible and will drive CMOS logic levels into a CMOS load.

ANALOG SPECIFICATIONS (TA = -40°C to 85°C; TV+, RV+ = 5.0 V ±5%; GND = 0 V)

Parameter	Min	Typ	Max	Units
Transmitter				
AMI Output Pulse Amplitudes (Note 7)				
E1, 75 . (Note 8)	2.14	2.37	2.6	V
E1, 120 . (Note 9)	2.7	3.0	3.3	V
T1, (FCC Part 68) (Note 10)	2.7	3.0	3.3	V
T1, DSX-1 (Note 11)	2.4	3.0	3.6	V
External Equalizer Pulse Amplitude	4.8	5.6	6.4	V
Transmitter Output Impedance (Note 13)				
Transformer turns ratio = 1:2 Low Z, Long Haul		1.5		.
Transformer turns ratio = 1:1.5				
E1, 75 .		33		.
E1, 120 .		53		.
T1, FCC		44		.
T1, DSX1		44		.
T1, Ext. Equal		44		.
Jitter Added by the Transmitter (Note 12, 13)				
10 Hz - 8 kHz	-	0.015	-	UI
8k Hz - 40 kHz	-	0.015	-	UI
10 Hz - 40 kHz	-	0.015	-	UI
Broad Band	-	0.020	-	UI
Power in 2 kHz band about 772 kHz (Notes 7, 18)	12.6	15	17.9	dBm
Power in 2 kHz band about 1.544 MHz (referenced to power in 2 kHz band at 772 kHz) (Notes 7, 18)	-29	-38	-	dB
Positive to Negative Pulse Imbalance (Notes 7, 13)	-	0.2	0.5	dB
Transmitter Short Circuit Current (Notes 7, 14)	-	-	50	mA RMS

Notes: 7. Using a 0.47 μF capacitor in series with the primary of a transformer recommended in the Applications Section.

8. Pulse amplitude measured at the output of the transformer across a 75 . load for line length settings LEN[2:0] = 001 and 000.
9. Pulse amplitude measured at the output of the transformer across a 120 . load for line length setting LEN[2:0] = 000.
10. Pulse amplitude measured at the output of the transformer across a 100 . load for line length setting LEN[2:0] = 000.
11. Pulse amplitude measured at the DSX-1 Cross-Connect for all line length settings from LEN[2:0] = 011 to LEN[2:0] = 111.
12. Assuming that jitter free clock is input to TCLK. Jitter Attenuator not in path.
13. Not production tested. Parameters guaranteed by design and characterization.
14. Measured broadband through a 0.5 . resistor across the secondary of the transmitter transformer during the transmission of an all ones data pattern with LEN[2:0] = 000 or 001.

ANALOG SPECIFICATIONS (Continued)

Parameter	Min	Typ	Max	Units
Receiver				
RTIP/RRING Input Impedance	-	20k	-	.
Sensitivity Below DSX (0 dB = 3.0 V) Long Haul, T1	-40 30	- -	- -	dB mV
Sensitivity Below DSX (0 dB = 3.0 V) Long Haul, E1	-36 48	- -	- -	dB mV
Sensitivity Below DSX (0 dB = 3.0 V) T1 - Short Haul	-21 270	- -	- -	dB mV
Sensitivity Below G.703 (0 dB = 2.4 V) E1 - Short Haul	-15 430	- -	- -	dB mV
Loss of Signal Threshold (Note 18)				
Long Haul, T1 & E1	-	-42	-	dB
T1 Short Haul	-	-22	-	dB
E1 Short Haul	-	-16	-	dB
Data Decision Threshold (Note 18)				
(Note 15)				
T1, DSX-1	-	50	-	% of peak
T1, (FCC Part 68) and E1	-	50	-	% of peak
Allowable Consecutive Zeros before LOS	160	175	190	bits
Receiver Input Jitter Tolerance - Short Haul				
(Note 16)				
E1: 18 kHz - 100 kHz	0.20	-	-	UI
T1: 10 kHz - 100 kHz	0.4	-	-	UI
(Note 13) 2 kHz	6.0	-	-	UI
(Note 18) 10 Hz and below	300	-	-	UI
Receiver Input Jitter Tolerance - Long Haul				
(Note 17)				
E1:10 kHz - 100 kHz	0.20	-	-	UI
T1:10 kHz - 100 kHz	0.4	-	-	UI
(Note 13) 1 Hz	138	-	-	UI

- Notes: 15. Data decision threshold established after the receiver equalizer filters pulse overshoot and undershoot.
16. Jitter tolerance for 0 dB input signal level. Jitter tolerance increases at lower frequencies. See Figure 8.
17. See Receiver Jitter Tolerance Plot, Figure 8.
18. Guaranteed by design.

T1 SWITCHING CHARACTERISTICS (TA = -40°C to 85°C; TV+, RV+ = 5.0 V ±5%;
GND = 0 V; Inputs: Logic 0 = 0 V, Logic 1 = RV+; See Figures 1, 2, & 3)

Parameter	Symbol	Min	Typ	Max	Units
TCLK Frequency	f_{tclk}	-	1.544	-	MHz
MCLK Frequency (Note 19)	f_{mclk}	-	1.544	-	MHz
RCLK Duty Cycle (Notes 18, 20)	t_{pwh1}/t_{pw1}		50		%
Rise Time, All Digital Outputs (Note 21)	t_r	-	-	85	ns
Fall Time, All Digital Outputs (Note 21)	t_f	-	-	85	ns
TPOS/TNEG to TCLK Falling Setup Time	t_{su2}	25	-	-	ns
TCLK Falling to TPOS/TNEG Hold Time	t_{h2}	25	-	-	ns
RPOS/RNEG Valid Before RCLK Falling (Note 22)	t_{su1}	150	274	-	ns
RPOS/RNEG Valid Before RCLK Rising (Note 23)	t_{su1}	150	274	-	ns
RPOS/RNEG Valid After RCLK Falling (Note 22)	t_{h1}	150	274	-	ns
RPOS/RNEG Valid After RCLK Rising (Note 23)	t_{h1}	150	274	-	ns

Notes: 19. MCLK provided by an external source or TCLK.

20. RCLK duty cycle will be 62.5% or 37.5% when jitter attenuator FIFO limits are reached.

21. At max load of 1.6 mA and 50 pF.

22. Host Mode (CLKE = 1).

23. Host Mode (CLKE = 0)

E1 SWITCHING CHARACTERISTICS (TA = -40°C to 85°C; TV+, RV+ = 5.0 V ±5%;
GND = 0 V; Inputs: Logic 0 = 0 V, Logic 1 = RV+; See Figures 1, 2, & 3)

Parameter	Symbol	Min	Typ	Max	Units
TCLK Frequency	f_{tclk}	-	2.048	-	MHz
MCLK Frequency (Note 19)	f_{mclk}	-	2.048	-	MHz
RCLK Duty Cycle (Notes 18, 20)	t_{pwh1}/t_{pw1}		50		%
Rise Time, All Digital Outputs (Note 21)	t_r	-	-	85	ns
Fall Time, All Digital Outputs (Note 21)	t_f	-	-	85	ns
TPOS/TNEG to TCLK Falling Setup Time	t_{su2}	25	-	-	ns
TCLK Falling to TPOS/TNEG Hold Time	t_{h2}	25	-	-	ns
RPOS/RNEG Valid Before RCLK Falling (Note 22)	t_{su1}	100	194	-	ns
RPOS/RNEG Valid Before RCLK Rising (Note 23)	t_{su1}	100	194	-	ns
RPOS/RNEG Valid After RCLK Falling (Note 22)	t_{h1}	100	194	-	ns
RPOS/RNEG Valid After RCLK Rising (Note 23)	t_{h1}	100	194	-	ns

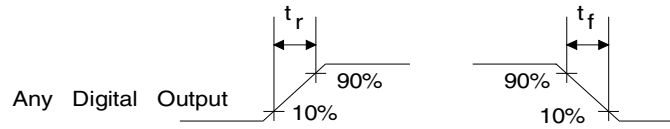

Figure 1. Signal Rise and Fall Characteristics

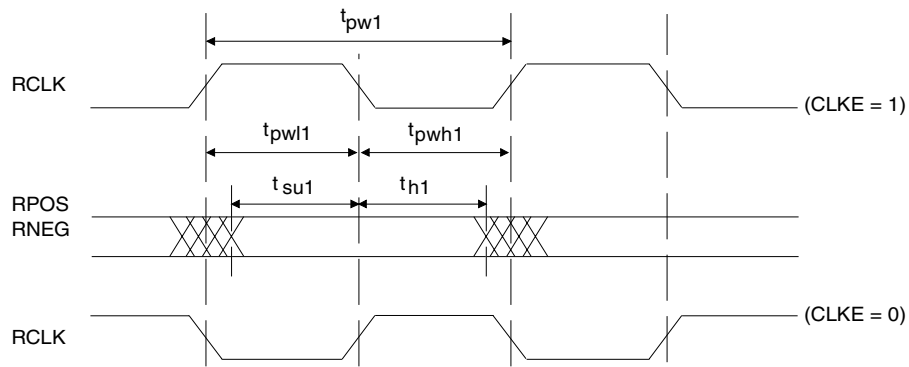

Figure 2. Recovered Clock and Data Switching Characteristics

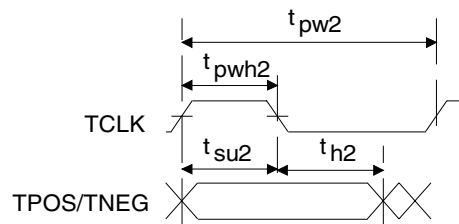

Figure 3. Transmit Clock and Data Switching Characteristics

SWITCHING CHARACTERISTICS (TA = -40° to 85°C; TV+, RV+ = 5V ±5%;

Inputs: Logic 0 = 0 V, Logic 1 = RV+)

Parameter	Symbol	Min	Typ	Max	Units
SDI to SCLK Setup Time	t_{dc}	50	-	-	ns
SCLK to SDI Hold Time	t_{cdh}	50	-	-	ns
SCLK Low Time	t_{cl}	240	-	-	ns
SCLK High Time	t_{ch}	240	-	-	ns
SCLK Rise and Fall Time	t_r, t_f	-	-	50	ns
CS to SCLK Setup Time	t_{cc}	50	-	-	ns
SCLK to CS Hold Time	t_{cch}	50	-	-	ns
CS Inactive Time	t_{cwh}	250	-	-	ns
SCLK to SDO Valid (Note 24)	t_{cdv}	-	-	200	ns
CS to SDO High Z	t_{cdz}	-	100	-	ns

Notes: 24. Output load capacitance = 50 pF

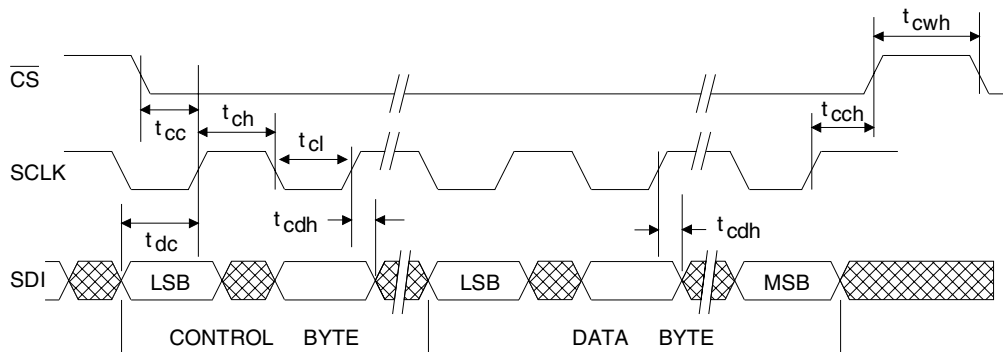
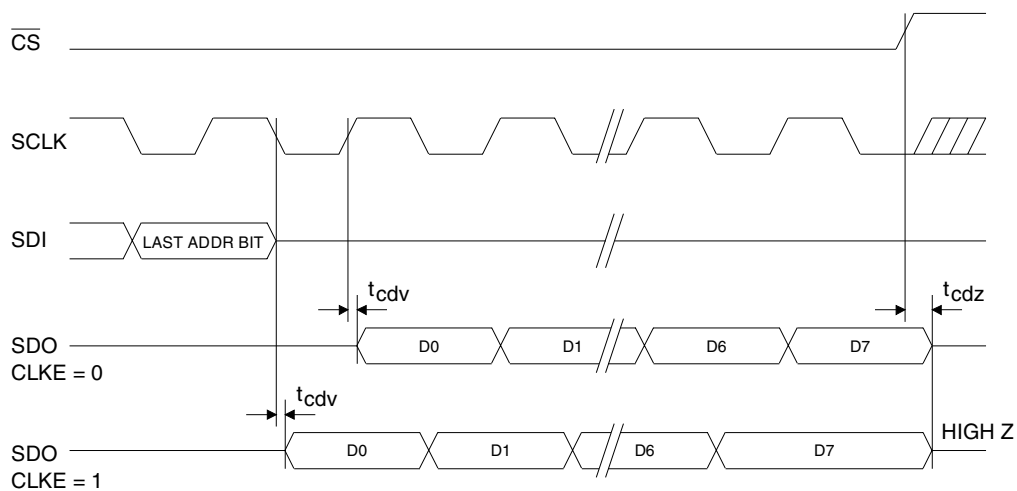
Figure 4. Serial Port Write Timing Diagram

Figure 5. Serial Port Read Timing Diagram

2. THEORY OF OPERATION

The CS61581 Universal Line Interface supports T1 and E1 data rates for both short haul and long haul applications. The transmitter complies with all standard T1 and E1 applications without changing transformers. Transmitter power consumption is minimized using the impedance matching feature, which eliminates external resistors for standard line impedances. When configured for long haul operation, the receiver uses gain and equalization to provide 40 dB of sensitivity. The receiver reconfigures for short haul operation, limiting the receive sensitivity and increasing the noise immunity.

2.1 Operating Mode Selection

The CS61581 can be operated in stand-alone hardware interface mode (MODE pin is low), or by a microcontroller in serial host mode (MODE pin is high). Additional functionality is available in the host mode including both short haul and long haul operational modes. The CS61581 defaults to the Long Haul configuration (LXT310/318 compatible). The T1 (DSX-1 and Network interface) and E1 (ITU-T G.703) are selectable via the serial port by writing to a control register.

Tying TNEG high for more than 16 TCLK cycles enables the unipolar mode, changing TPOS to TDATA, RPOS to RDATA, and RNEG to BPV. When configured for unipolar mode, the MODE pin can be tied to RCLK enabling the B8ZS encoders and decoders. Coder mode does not support bipolar data.

2.2 Master Clocks

The CS61581 requires a reference clock for the receiver and the jitter attenuator. Either a 1.544 MHz (or 2.048 MHz) external clock can be input to MCLK, or a 4X crystal can be connected to the on-chip oscillator. This frequency reference should be within 100 ppm of the nominal operating frequency. Jitter and wander on the reference clock will degrade jitter attenuation and receiver jitter tolerance.

If MCLK is provided, the crystal oscillator is ignored.

2.3 Transmitter

The transmitter accepts digital T1 or E1 input data and drives appropriately shaped AMI (Alternate Mark Inversion) pulses onto a transmission line through a transformer. The transmit data (TPOS & TNEG or TDATA) is sampled on the falling edge of the input clock, TCLK.

Upon power up, the CS61581 defaults to Long Haul Mode with low-impedance drive. In this mode, a 1:2 transformer is required (See Table 1). The CS61581 will support both T1 and E1 operation as determined by the master clock frequency.

In host mode, T1 (DSX-1 or Network Interface), E1 (ITU-T or G.703) or T1 long-haul pulse shapes may be selected. Long-haul or short-haul operation is determined by the SH/LH bit (CR2.0). The SH/LH bit also establishes functionality of Control Registers 1 and 2.

In the matched impedance configuration, the line driver internally matches the impedance of the line load; 75 Ω or 120 Ω for E1, and 100 Ω for T1 using a 1:1.5 turns ratio transformer. Internal impedance matching reduces current consumption by about a factor of two compared to return loss achieved by external resistors.

The T1 long-haul pulse shapes comply with FCC Part 68 Option A (0 dB), Option B (-7.5 dB), Option C (-15 dB) or (-22.5 dB) (see Table 1). If desired, the T1 pre-equalization settings can be selected for E1 operation as well. In long-haul mode, pulse shaping and signal level are controlled by LBO1 and LBO2 pins or register bits.

Custom transmit pulse shapes may be implemented by writing pulse shape coefficients to the registers. Custom pulses may be used to correct for pulse shape degradation or distortion caused by improper termination, suboptimal interconnect wiring, or

Long Haul

LB02	LB01	Output Pulse
0	0	0 dB
0	1	-7.5 dB
1	0	-15 dB
1	1	-22.5 dB

Mode	Transformer Turns Ratio	
	Transmit	Receive
HDW or MATCHZ* = 0	1:2	1:1
MATCHZ* = 1	1:1.5	1:1

* MATCHZ = CR2.5

Short Haul

LEN2	LEN1	LEN0	Output Pulse	Line Z
0	0	0	E1 2.37 V	75.
0	0	1	E1 3.0 V	120.
0	1	1	DSX-1 0'-133'	100.
1	0	0	DSX-1 133'-266'	100.
1	0	1	DSX-1 266'-399'	100.
1	1	0	DSX-1 399'-533'	100.
1	1	1	DSX-1 533'-655'	100.
0	1	1	ANSI T1.403	100.
0	1	0	FCC Part 68, Option A 6.0 V	100.

Table 1. Pulse Shape Selection and Transformer Requirements

loading from external components such as high voltage protection devices.

For T1 DSX-1 applications, line lengths from 0 to 655 feet (as measured from the transmitter to the DSX-1 cross connect) may be selected. The five partition arrangement in Table 1 meets ANSI T1.102 pulse shape requirements when using #22 ABAM or AT&T 600 series cable. A typical output pulse is shown in Figure 6. These pulse settings can also be used to meet ITU-T pulse shape requirements for 1.544 MHz operation. Short haul pulse shapes for T1 and E1 are selected by the LEN[2:0] bits in Control Register 1.

Note that when the device is operated at E1 frequency in the hardware mode, it defaults to low impedance, long haul mode. The pulses driven by the transmitter in this mode are T1.403 (350ns) pulses with an overshoot and an undershoot. To drive

pulses without overshoot and undershoot in E1 long haul mode, the E1_LH bit (CR3.6) must be set to 1, with the SH/LH bit (CR2.0) set to 0.

The E1 G.703 pulse shape is supported with line length selections LEN[2:0] = 000 for 2.37 V 75. applications or LEN[2:0] = 001 for 3.0 V 120. applications. The output pulse will meet the G.703 pulse shape template shown in Figure 7. The output impedance of the driver will adjust according to the pulse shape selected.

In the short haul mode, setting the LEN[2:0] bits also controls the transmitter output impedance. For long haul operation, driver impedance is determined by the desired selection of MATCHZ and E1_LH bits. When MATCHZ is set to "0" the output impedance is low, and the impedance presented to the line is controlled by external resistors. When MATCHZ is set to 1, E1_LH determines whether

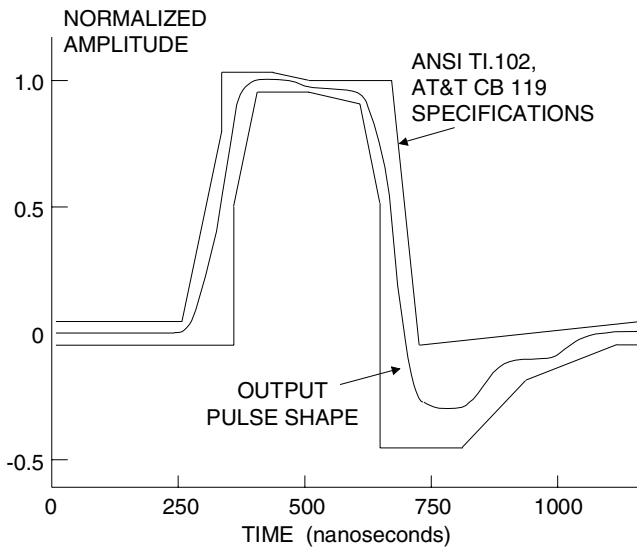

Figure 6. Typical Pulse Shape at DSX-1 Cross Connect

the driver is set for 100. ($E1_LH = 0$) or 120. ($E1_LH = 1$).

The CS61581 will detect the absence of TCLK, and will force TTIP and TRING to high impedance after 175 bit periods, preventing transmission when data input is not present. In host mode, the transmitter can be set to high impedance by setting the TxHIZ bit, CR2.1, to “1.”

When any transmit control bit (TAOS, LEN0-2, LBO1-2, or LLOOP) is toggled, the transmitter outputs will require approximately 22 bit periods to stabilize. The transmitter will take longer to stabilize when RLOOP is selected because the timing circuitry must adjust to the new frequency.

The CS61581 has the option to drive a $6 V_{peak}$ pulse. The option is used for driving external equalizers used in T1 DSX applications that conform to FCC Part 68, Option A. This configuration is selected by setting the LEN[2:0] control bits in register 0x10 to 010 in the short haul configuration. The

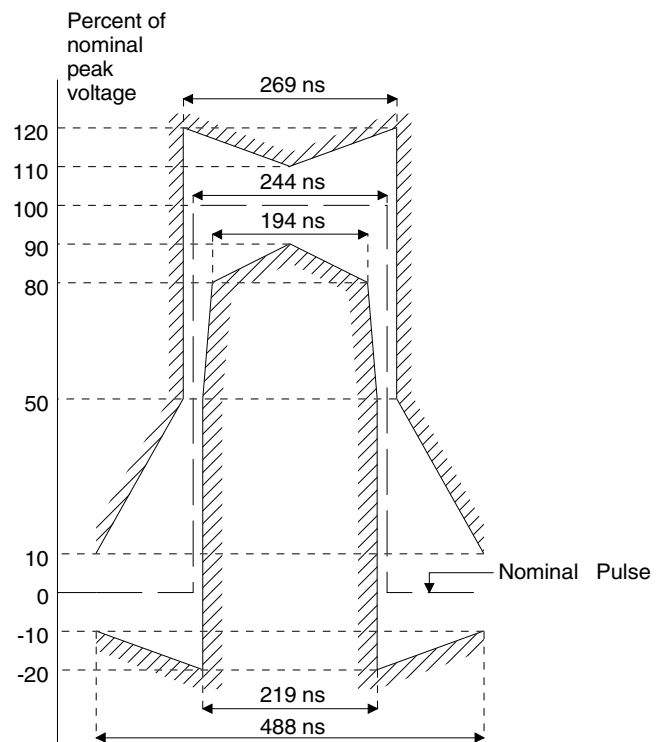

Figure 7. Mask of the Pulse at the 2048 kbps Interface

turns ratio of the transmit transformer must be set accordingly: in Matched Impedance mode, the turns ratio must be 1:1.5; in Low Impedance mode, the transformer turns ratio = 1:2.6.

2.4 Transmit All Ones Select

The transmitter provides for all ones insertion at the frequency of TCLK. If TCLK is absent, then MCLK is used (or the quartz crystal generated frequency in the absence of MCLK). Transmit all ones is selected when TAOS (pin 28 in hardware mode, CR1.7 in host mode) goes high, and causes continuous ones to be transmitted on the line (TTIP and TRING). When TAOS is active, the TPOS and TNEG (TDATA) inputs are ignored. If Remote Loopback is in effect, any TAOS request will be ignored.

2.4.1 Receiver

The receiver extracts data and clock from the input signal and outputs clock and synchronized data. The RTIP and RRING inputs are biased to an intermediate DC level so that the input is received as a differential signal. The incoming pulses are amplified, equalized and filtered before being fed to the comparator for peak detection, slicing and data recovery. A noise and cross-talk filter removes signal components that are coupled onto the line from other cables. T1 or E1 operation is determined by the transmit pulse shape selection, LEN[2:0].

The clock and data recovery circuit exceeds the jitter tolerance specifications of Publications 43802, 43801, AT&T 62411, TR-TSY-000170, ITU-T G.823 and ETSI TBR12/13. Jitter tolerance is shown in Figure 8.

In Hardware mode, the receiver is configured for Long Haul operation. In Host mode Short Haul operation can be selected by setting the SH/LH (CR2.0) to 1. When configured for short haul, the functions of registers 0x10 and 0x11 are redefined.

2.4.2 Short Haul

Receiver sensitivity is set to comply with ITU-T I.431 requirements for E1 and T1. The comparator

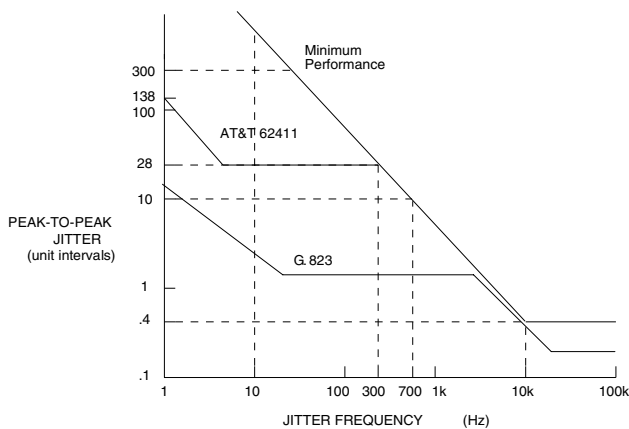

Figure 8. Minimum Input Jitter Tolerance of Receiver

thresholds are dynamically established at 50% percent of the peak level. This is acceptable for both T1 and E1 cases as pulse undershoot and overshoot are filtered internally.

2.4.3 Long Haul

Configuring the receiver for long haul operation increases the receive sensitivity. To select long haul mode, the SH/LH (CR2.0) bit must be set to 0; for E1 long haul mode, the E1_LH bit (CR3.6) must be set to 1.

2.4.4 Clock Recovery

The clock recovery circuit is a third-order phase lock loop. The clock and data recovery circuit is tolerant of long strings of consecutive zeros, and will successfully receive a 1-in-175, jitter-free input signal.

In Hardware mode, data on RPOS and RNEG (RDATA), is stable on the rising edge of recovered clock, RCLK. In host mode, CLKE (pin 28) determines the clock polarity for which output data is valid, as shown in Table 2. When CLKE is high, RPOS and RNEG (RDATA) are valid on the falling edge of RCLK. When CLKE is low, RPOS and RNEG are valid on the rising edge of RCLK.

MODE (pin 5)	CLKE (pin 28)	DATA	CLOCK	Clock Edge for Valid Data
LOW	Don't Care	RPOS RNEG	RCLK	Rising
HIGH	LOW	RPOS RNEG SDO	RCLK RCLK SCLK	Rising Rising Falling
		RPOS RNEG SDO	RCLK RCLK SCLK	Falling Falling Rising

Table 2. Data Output/Clock Relationship

2.4.5 Jitter Tolerance

The receiver jitter tolerance is shown in Figure 8. The CS61581 jitter tolerance exceeds AT&T 62411 in T1 applications, and G.823 in E1 applications.

2.5 Receiver Line Attenuation Indication

LATN (pin 18) outputs a coded signal that represents the signal level at the input of the receiver. As shown in Figure 9, the LATN output is measured against RCLK to provide the signal level in 7.5 dB increments. In host mode, the receive input signal level can be read from the Equalizer Gain register (address 0x12), to greater resolution, dividing the input range into 20 steps of 2 dB increments.

2.6 Jitter Attenuator

The jitter attenuator reduces the amount of jitter and wander in the input signal. The jitter attenuator is built around a FIFO; the write pointer of the FIFO is driven by the input clock, and the read pointer is driven by a phase locked loop (PLL). The jitter attenuator can be placed in either the transmit or receive paths; in the transmit path, writing to the FIFO is controlled by TCLK; if the jitter attenuator is in the receive path, writing is controlled by the recovered clock from the input data. The jitter attenuator does not require an external crystal. If a crystal is present, the PLL uses it for a reference; otherwise, MCLK provides the reference.

The jitter attenuator is enabled if an external crystal is connected. If no crystal is present, then the jitter attenuator is enabled by either grounding or floating XTALIN (pin 9). It is disabled by tying XTALIN high. It is placed in the transmit or receive paths by setting JASEL (pin 11) either low or high, respectively.

The jitter attenuator has two modes of operation depending on whether the CS61581 is configured for T1 or E1 operation (based on the output pulse shape selection). For T1, the jitter attenuator corner frequency is set at 4 Hz, with attenuation increasing at a 20 dB per decade rate above 4 Hz. For E1 the corner frequency is approximately 1.25 Hz in order to comply with ETSI 300 011, TBR12/13, and recommendation I.431. Complying to these specifications also guarantees compliance to less stringent standards, such as G.736. Typical jitter attenuation curves are shown in Figures 10 and 11.

2.7 Receiver Loss of Signal

The receiver will indicate loss of signal by asserting LOS (pin 12, also CR1.0 in host mode). This happens on power up, reset, when the receiver gain reaches its maximum, or on receiving 175+/-15 consecutive zeros. Received zeros are counted based on recovered clock cycles. When in the LOS state, received data is not output from RPOS/RNEG (RDATA); but is squelched until the device comes out of LOS. The LOS condition is ex-

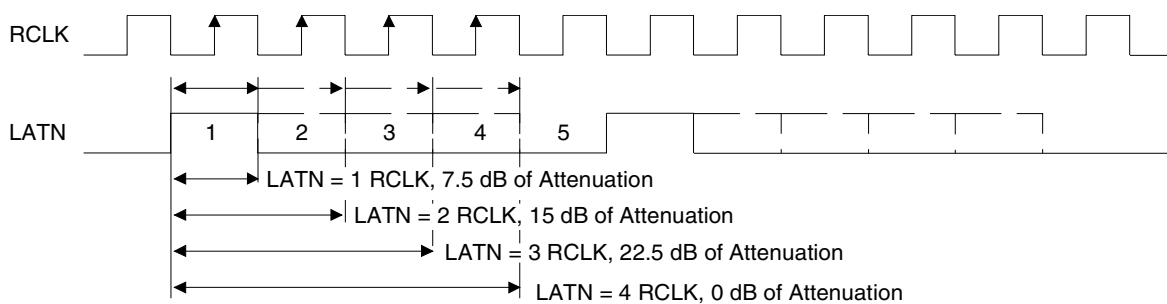

Figure 9. LATN Pulse Width encoding

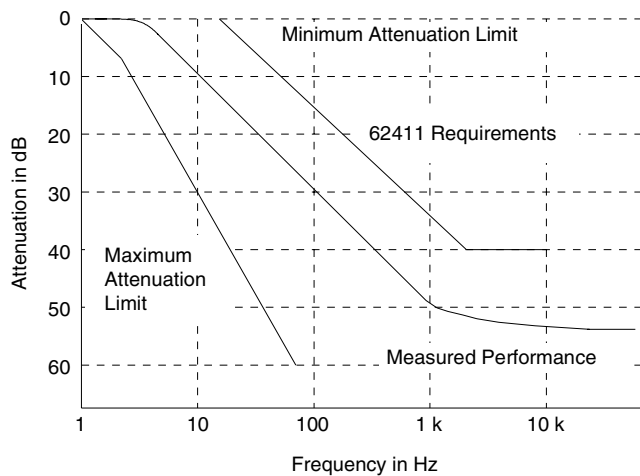

Figure 10. Typical Jitter Transfer Function - T1

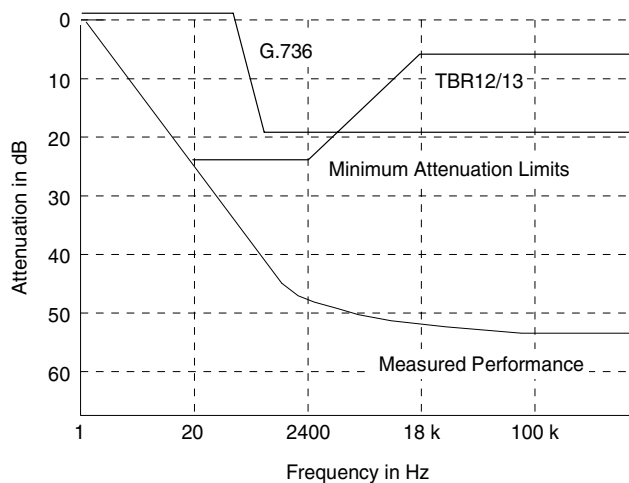

Figure 11. Typical Jitter Transfer Function - E1

ited using the ANSI T1.231-1993 and ITU-T G.775 criteria, namely 12.5% ones density for 175+/-75 bit periods with no more than 100 consecutive zeros.

In Long Haul operation, the receiver recovers signals down to -40 dB for T1 and -36 dB for E1. In Short Haul mode, the receive sensitivity is typically -21 dB for T1 and -15 dB for E1, in accordance with I.431 and G.775. LOS will be declared beyond

these signal levels. These LOS thresholds are compliant with all Short Haul applications.

In LOS, the RCLK frequency depends on whether MCLK is applied, and whether the jitter attenuator is in the transmit or receive path. If the jitter attenuator is in the receive path, the jitter attenuator will hold over the average incoming data frequency prior to LOS. RPOS (RDATA) and RNEG pins are forced low upon LOS.

When the jitter attenuator is in the transmit path or not used, the clock recovery is referenced to MCLK, if provided, or the crystal oscillator. The frequency of RCLK in this case will simply remain slaved to the clock reference upon loss of data. The recovered clock remains as a 50% duty cycle clock.

The digital PLL in the clock recovery circuit of the CS61581 generates an internal data clock from the edges of the incoming pulses (1's).

Timing is recovered by a phase selector which selects one of the phases from the internal synchronization clock (one of three clocks, 120 degrees apart in phase, at 16X the data rate). Since the selection is made between a limited set of phases, the Digital Timing Recovery process has a small phase error built into the sampling process. By choosing 48 possible sampling phases, the CS61581 reduces the sampling error to a minimum.

2.8 Local Loopback

Local loopback is selected by setting LLOOP high (pin 27 in Hardware mode, CR1.6 in Host mode). Selecting local loopback causes the clock and data on TCLK, TPOS and TNEG (TDATA) to be output on RCLK, RPOS and RNEG (RDATA). The RTIP/RRING inputs have no effect on RCLK, RPOS and RNEG (RDATA) in this mode. Inputs to the transmitter are still transmitted on TTIP and TRING unless TAOS has been selected, in which case AMI-encoded continuous ones are transmitted at the TCLK frequency.

2.9 Remote Loopback

Remote loopback is selected by setting RLOOP high (pin 26 in Hardware mode, CR1.5 in Host mode). In remote loopback, the recovered clock and data input on RTIP and RRING are sent back out on the line via TTIP and TRING. Selecting remote loopback overrides a TAOS request. The recovered clock and data from the incoming signal are also sent to RCLK, RPOS and RNEG (RDATA). Simultaneous selection of local and remote loopback modes will cause a device reset to occur (see Reset).

2.10 Network Loopback

During Network Loopback (automatic remote loopback), the data path and operation of the device is identical to Remote Loopback, except this loopback mode is controlled by the transmitter at the other end of the loop. It is initiated by enabling Network Loopback detection on the device. In Host Mode, Network Loopback (NLOOP) detection is enabled by writing ones to TAOS, LLOOP and RLOOP, then clearing them. In hardware mode, Network Loopback can be enabled by tying RLOOP to RCLK or by setting TAOS, LLOOP, and RLOOP high for at least 200 ns, and then low. Once enabled Network Loopback functionality will remain in effect until RLOOP is activated or the device is reset.

When NLOOP detection is enabled, the receiver monitors the input data stream for the LOOP UP data pattern: a repeating 00001. When this pattern is repeated for a minimum of five seconds (with less than 10^{-3} BER), the device sets its internal data path as in Remote Loopback. It stays in this mode until the LOOP DOWN pattern (repeating 001) is received for 5 seconds, or by activation of RLOOP. NLOOP is temporarily suspended by LLOOP, but the NLOOP state is not reset.

The device can also generate the LOOP UP and LOOP DOWN sequences by setting the LOOPUP (CR2.3) or LOOPDN (CR2.4) bits respectively.

The Network Loopback generation and detection functions are only available in Long Haul mode.

2.11 Alarm Indication Signal

The receiver sets the register bit, AIS, to “1” when less than 9 zeros are detected out of 8192 bit periods. AIS returns to “0” upon the first read after the AIS condition is removed, determined by 9 or more zeros out of 8192 bit periods.

Some operations change the definition of other bits. Writing a 1 or 0 to SH/LH (CR2.0 = 1), places the device in Short Haul or Long Haul mode respectively, and the definition of Control Registers 1 and 2 are modified accordingly. In Long Haul mode, E1 operation can be enabled by setting E1_LH to 1 (CR3.6 = 1), changes CR1.2 from B8ZS to HDB3. Enabling unipolar mode by setting TNEG (pin 4) high for 16 clocks allows the user to enable coder mode using the CODER bit (CR1.2LH). When TNEG is low, enabling bipolar mode, CR1.2LH is the TAZ bit (transmit all zeroes).

2.12 Serial Interface

In the Host Mode, pins 24 through 28 serve as a microcontroller interface. On-chip registers can be written to via the SDI pin or read from via the SDO pin at the clock rate determined by SCLK. Through these registers, a host controller can be used to control operational characteristics and monitor device status. The serial port read/write timing is independent of the system transmit and receive timing.

Data transfers are initiated by taking the chip select input, \overline{CS} , low (\overline{CS} must initially be high). Address and input data bits are clocked in on the rising edge of SCLK. The clock edge on which output data is stable and valid is determined by CLKE as shown in Table 2. Data transfers are terminated by setting CS high. CS may go high no sooner than 50 ns after the rising edge of the SCLK cycle corresponding to the last write bit. For a serial data read, \overline{CS} may go high any time to terminate the output and set SDO to high impedance.

Figure 12 shows the timing relationships for data transfers when $CLKE = 0$. When $CLKE = 1$, data bit D7 is held until the falling edge of the 16th clock cycle. When $CLKE = 0$, data bit D7 is held valid until the rising edge of the 17th clock cycle. SDO goes high-impedance after \overline{CS} goes high or at the end of the hold period of data bit D7.

SDO goes to a high impedance state when not in use. SDO and SDI may be tied together in applications where the host processor has a bidirectional I/O port.

An address/command byte, shown in Figure 12, points to addresses 0x10 through 0x15 (address 0x10 shown), and precedes a data byte. The first bit of the address/command byte determines whether a read or a write is requested. The next six bits contain the address. The last bit is ignored. Data to the internal registers is input on the eight clock cycles immediately following the address/command byte. The register bit assignments are shown in Table 3.

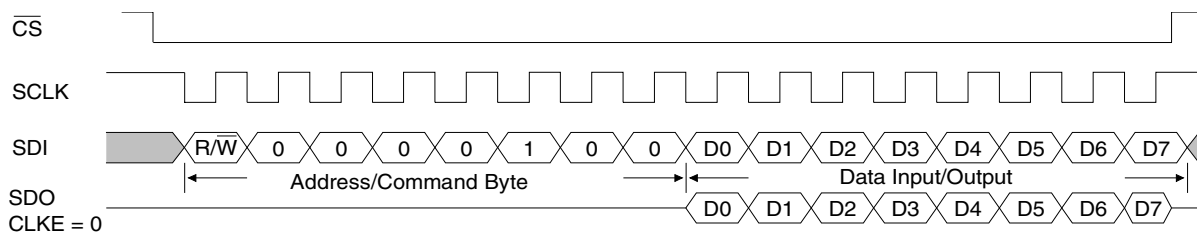

Figure 12. Input/Output Timing (showing address 0x10)

	7	6	5	4	3	2	1	0	ADDR
Control Register 1 LH (CR2.0 = 0) (CR1LH)	TAOS	LLOOP	RLOOP	LB02	LB01	CODER TAZ	NLOOP	LOS	0x10 R/W
Control Register 1 SH (CR2.0 = 1) (CR1SH)	TAOS	LLOOP	RLOOP	LEN2	LEN1	LEN0	RSVD	LOS	0x10 R/W
Control Register 2 LH (CR2.0 = 0) (CR2LH)	AIS	RAMPLSE	MATCHZ	LOOPDN	LOOPUP	RPWDN	TxHIZ	SH/LH	0x11 R/W
Control Register 2 SH (CR2.0 = 1) (CR2SH)	AIS	RAMPLSE	MATCHZ	RSVD	RCODER	TCODER	TxHIZ	SH/LH	0x11 R/W
Equalizer Gain (EQGAIN)	X	X	X	EQ4	EQ3	EQ2	EQ1	EQ0	0x12 R
RAM Address (RAM)	MSB	-	-	-	-	-	-	LSB	0x13 R/W
Control Register 3 (CR3)	QRSS- PATH	E1_LH	RST_ QERR	QDET	INS_QERR	QSYNC TEST	QGEN	TEST	0x14 R/W
Data Pattern Error Count (DPEC)	MSB	-	-	-	-	-	-	LSB	0x15 R

Table 3. Register Map

2.13 Control Register 1 LH (CR2.0 = 0): Address 0x10

7 (MSB)	6	5	4	3	2	1	0 (LSB)
TAOS	LLOOP	RLOOP	LB02	LB01	CODER TAZ	NLOOP	LOS

TAOS	Transmit All Ones Select When TAOS = 1, all ones are transmitted at the TCLK frequency															
LLOOP	Local Loopback When LLOOP = 1, data input at TPOS, TNEG (TDATA) is internally looped back and output on RPOS, RNEG (RDATA). TCLK is routed to RCLK, through the jitter attenuator, if activated.															
RLOOP	Remote Loopback When RLOOP = 1, clock and data recovered by the receiver are sent back through the transmit path and retransmitted. The clock and data are routed through the jitter attenuator, if activated.															
LBO[2:1]	Line Build Out <table> <thead> <tr> <th>LBO2</th> <th>LBO1</th> <th>Attenuation</th> </tr> </thead> <tbody> <tr> <td>0</td> <td>0</td> <td>0 dB</td> </tr> <tr> <td>0</td> <td>1</td> <td>-7.5 dB</td> </tr> <tr> <td>1</td> <td>0</td> <td>-15 dB</td> </tr> <tr> <td>1</td> <td>1</td> <td>-22.5 dB</td> </tr> </tbody> </table> For E1 long haul, only the 0 dB setting should be used when the part is configured for matched impedance drive.	LBO2	LBO1	Attenuation	0	0	0 dB	0	1	-7.5 dB	1	0	-15 dB	1	1	-22.5 dB
LBO2	LBO1	Attenuation														
0	0	0 dB														
0	1	-7.5 dB														
1	0	-15 dB														
1	1	-22.5 dB														
CODER	Zero Substitution (valid only when TNEG (UBS) is tied high, invoking unipolar mode). In Long Haul mode, setting CODER to "1" enables B8ZS (HDB3) encoding and decoding. The substitution depends on whether the CS61581 is configured for T1 or E1 operation. via the E1_LH bit, CR3.6															
(TAZ)	Transmit All Zeroes (valid only when TNEG (UBS) is tied low, invoking bipolar mode). When in bipolar mode (TPOS/TNEG are data inputs) setting TAZ to "1" causes all zeros to be transmitted.															
NLOOP	Network Loopback NLOOP = 1 when a network loopback code has been detected on the received signal. An interrupt will occur when NLOOP changes state unless a "1" is written to NLOOP disabling the interrupt.															
LOS	Loss Of Signal LOS = 1 when the loss of signal criteria have been met (175 zeros). LOS = 0 when a valid signal is being received. An interrupt will occur when LOS changes state unless a "1" is written to LOS disabling the interrupt.															

2.14 Control Register 1 SH (CR2.0 = 1): Address 0x10

7 (MSB)	6	5	4	3	2	1	0 (LSB)
TAOS	LLOOP	RLOOP	LEN2	LEN1	LEN0	RSVD	LOS

TAOS	<p>Transmit All Ones Select</p> <p>When TAOS = 1, all ones are transmitted at the TCLK frequency</p>
LLOOP	<p>Local Loopback</p> <p>When LLOOP = 1, data input at TPOS/TNEG (TDATA) is internally looped back and output on RPOS/RNEG (RDATA). TCLK is routed to RCLK, through the jitter attenuator, if activated.</p>
RLOOP	<p>Remote Loopback</p> <p>When RLOOP = 1, clock and data recovered by the receiver are sent back through the transmit path and retransmitted. The clock and data are routed through the jitter attenuator, if activated.</p>
LEN [2:0]	<p>Line Length Selection</p> <p>Allows selection of a variety of transmit pulse shapes. See Table 1 for details.</p> <p>Note that the selection of T1 or E1 pulse shapes determines the operation of the device. When MATCHZ is set to "1" the transmitter's output impedance changes according to the pulse selected. For T1 pulses, the encoders and decoders are set to B8ZS, and the QRSS data pattern is $2^{20}-1$ with 14 consecutive zeros, max. For E1 pulses, the encoders and decoders are set to HDB3, and the QRSS data pattern is $2^{15}-1$.</p>
RSVD	<p>This bit is reserved.</p>
LOS	<p>Loss Of Signal</p> <p>LOS = 1 when the loss of signal criteria have been met (175 zeros).</p> <p>LOS = 0 when a valid signal is being received.</p> <p>An interrupt will occur when LOS changes state unless a "1" is written to LOS disabling the interrupt.</p>

2.15 Control Register 2 LH: Address 0x11

7 (MSB)	6	5	4	3	2	1	0 (LSB)
AIS	RAMPLSE	MATCHZ	LOOPDN	LOOPUP	RPWDN	TxHIZ	SH/LH

AIS	<p>Alarm Indication Signal.</p> <p>AIS = 1 when an all ones pattern is present at the receiver. This bit is reset to “0” by the first read occurring after the AIS condition has cleared.</p> <p>An interrupt will occur when AIS is present unless a “1” is written to AIS disabling the interrupt.</p>
RAMPLSE	<p>When RAMPLSE = 1, output pulse shapes are determined by the codes in the internal, programmable, transmit RAM.</p>
MATCHZ	<p>Matched Impedance Drive</p> <p>When MATCHZ = 1 the output impedance is automatically set to match the impedance of a standard T1 or E1 line.</p> <p>A 1:1.5 transformer should be used when MATCHZ = 1, and a 1:2 transformer should be used when MATCHZ = 0. (See Figures 15 and 16.)</p>
LOOPDN	<p>Loop Down</p> <p>In Long Haul mode, setting LOOPDN to “1” causes the data pattern 001001... to be repetitively transmitted.</p>
LOOPUP	<p>Loop Up</p> <p>In Long Haul mode, setting LOOPUP to “1” causes the data pattern 0000100001... to be repetitively transmitted.</p>
RPWDN	<p>Receiver Power Down</p> <p>When RPWDN = 1, the receiver circuitry is powered down, but the transmitter is still active.</p>
TxHIZ	<p>Transmitter High Impedance</p> <p>When TxHIZ = 1 the transmitter goes to a low-power, high-impedance state</p>
SH/LH	<p>Short Haul / Long Haul Select</p> <p>When SH/LH = 0, the CS61581 is in the Long Haul mode.</p> <p>When SH/LH = 1, the CS61581 is in the Short Haul mode. Note that it overwrites the E1_LH bit, if set.</p> <p>SH/LH controls the functions of the bits in Control Register 1 (address 0x10) and Control Register 2 (address 0x11).</p>

2.16 Control Register 2 SH: Address 0x11

7 (MSB)	6	5	4	3	2	1	0 (LSB)
AIS	RAMPLSE	MATCHZ	RSVD	RCODER	TCODER	TxHIZ	SH/LH

AIS	Alarm Indication Signal. AIS = 1 when an all ones pattern is present at the receiver. This bit is reset to “0” by the first read occurring after the AIS condition has cleared. An interrupt will occur when AIS is present unless a “1” is written to AIS disabling the interrupt.
RAMPLSE	When RAMPLSE = 1, output pulse shapes are determined by the codes in the internal RAM.
MATCHZ	Matched Impedance Drive When MATCHZ = 1 the output impedance is automatically set to match the impedance of a standard T1 or E1 line. A 1:1.5 transformer should be used when MATCHZ = 1, and a 1:2 transformer should be used when MATCHZ = 0. (See Figures 15 and 16.)
RSVD	Reserved. Set to “0” for normal operation.
RCODER	Receive Decoder Enable In Short Haul mode, when TNEG is held high, setting RCODER to “1” causes the received data to be B8ZS/HDB3 decoded (depends on T1 or E1 pulse shape selection). When RCODER is set to “0” the decoders are set for AMI only. This bit has precedence over the external pin.
TCODER	Transmit Encoder Enable In Short Haul mode, when TNEG is held high, when TCODER = 1 the transmitter B8ZS/HDB3 encoders are enabled (depends on T1 or E1 pulse shape selection). When TCODER is set to “0” the decoders are set for AMI only. This bit has precedence over the external pin.
TxHIZ	Transmitter High Impedance When TxHIZ = 1 the transmitter goes to a low-power, high-impedance state
SH/LH	Short Haul / Long Haul Select When SH/LH = 0, the CS61581 is in the Long Haul mode. When SH/LH = 1, the CS61581 is in the Short Haul mode. SH/LH controls the functions of the bits of Control Register 1 (address 0x10), and Control Register 2 (address 0x11).

2.17 Equalizer Gain (EQGAIN): Address 0x12

7 (MSB)	6	5	4	3	2	1	0 (LSB)
X	X	X	EQ4	EQ3	EQ2	EQ1	EQ0

EQ[4:0]	The receive equalizer gain settings are broken down into 20 segments and provided at the five LSBs of this register, EQ4 - EQ0. 00001 corresponds to -2 dB, 10100 corresponds to -40 dB. The three MSBs are don't cares.
----------------	--

2.18 RAM Address (RAM): Address 0x13

7 (MSB)	6	5	4	3	2	1	0 (LSB)
RAM.7	RAM.6	RAM.5	RAM.4	RAM.3	RAM.2	RAM.1	RAM.0

RAM[7:0]	The RAM address pointer for the arbitrary waveform memory; a special write procedure must be followed to write the waveform RAM.
-----------------	--

2.19 Control Register 3 (CR3): Address 0x14

7 (MSB)	6	5	4	3	2	1	0 (LSB)
QRSSPATH	E1_LH	RST_QERR	QDET	INS_QERR	QSYNC/Test	QGEN	Test

QRSSPATH	When QRSSPATH = 0 the QRSS pattern will be output from the recovered data pins, RPOS, RNEG (RDATA), and may be received at the transmitter inputs, TPOS, TNEG (TDATA). When QRSSPATH = 1 the QRSS pattern will be output from the line transmitter and may be received at the receiver.
E1_LH	E1 Long Haul When E1_LH = 1 and SH/LH (CR2.0) = 0, the following functionality applies: Coder mode selects HDB3 coding and decoding; when MATCHZ = 1, the output impedance of the transmitter will be set to match impedances near 120. ; the QRSS pattern is 2 ¹⁵ -1; the jitter attenuator is adjusted for TBR12/13 compliance, with the knee in the frequency response at 1.25 Hz. When E1_LH = 0 and SH/LH = 0, the following functionality applies: Coder mode selects B8ZS coding and decoding; when MATCHZ = 1, the output impedance of the transmitter will be set to match impedances near 100. ; the QRSS pattern is 2 ²⁰ -1; the jitter attenuator is adjusted for AT&T 62411 compliance, with the knee in the frequency response at 4 Hz. This bit is ignored if SH/LH = 1.
RST_QERR	Reset Data Pattern Error Count Register Setting RST_QERR to “1” will clear the QRSS error count in the DPEC register. This bit is automatically cleared and will read as “0.”
QDET	QRSS Detector Enable When QDET = 1, the QRSS pattern detector is enabled. Errors detected and counted are stored in the DPEC register (address 0x15).
INS_QERR	QRSS Error Insert Setting INS_QERR to “1” and then “0” causes an error to be inserted in the output QRSS pattern.
QSYNC/Test	QSYNC reads as “1” to indicate when the QRSS detector is synchronized to an input pattern. QSYNC is only valid when QDET = 1 enabling the pattern detector. When writing this register, this bit must be set to “0” for normal operation.
QGEN	QRSS Generator Enable When QGEN = 1, the QRSS generator is enabled. The QRSS pattern is output at the TTIP/TRING pins, or at the RPOS/RNEG (RDATA) pins, depending upon the state of the QRSSPATH bit. Errors can be generated using the INS_QERR bit.
Test	Bit should be set to “0” for normal operation.

2.20 Data Pattern Error Count (DPEC): Address 0x15

7 (MSB)	6	5	4	3	2	1	0 (LSB)
DPEC.7	DPEC.6	DPEC.5	DPEC.4	DPEC.3	DPEC.2	DPEC.1	DPEC.0

DPEC[7:0]	Errors detected in the input QRSS pattern are counted and stored. This register saturates at 255 errors. The DPEC is cleared when the RST_QERR bit is written in the CR3 register.
-----------	--

2.21 Interrupts

An interrupt will occur ($\overline{\text{INT}}$ pulls low) in response to a change in the LOS, AIS or NLOOP bits. The interrupt is cleared when the host processor writes a “1” to the respective bit in the control register.

Writing a “1” to LOS or NLOOP over the serial interface has three effects:

- 1) The current interrupt on the serial interface will be cleared. (Note that simply reading the register bits will not clear the interrupt).
- 2) Output data bits 5, 6 and 7 will be reset as appropriate.
- 3) Interrupts for the corresponding LOS and NLOOP will be prevented from occurring.

Writing a “0” to either LOS or NLOOP enables the corresponding interrupt for LOS and NLOOP.

Reading the registers returns their current status or setting. Register 0x10 outputs the status NLOOP and LOS and has bits 5, 6, and 7 encoded as shown in Tables 4 and 5.

Bits			Long Haul Mode Status
7	6	5	
0	0	0	Reset has occurred, or no program input
0	0	1	RLOOP active
0	1	0	LLOOP active
0	1	1	LOS has changed state since last Clear LOS occurred
1	0	0	TAOS active
1	0	1	NLOOP has changed state since last Clear NLOOP occurred
1	1	0	TAOS and LLOOP active
1	1	1	LOS and NLOOP have both changed state since last Clear NLOOP and Clear LOS

Table 4. Register 0x10 Decoding

3. QRSS TEST MODE

In Host Mode, the CS61581 has the capability to generate and detect a QRSS ($2^{20}-1$ with 14 zeros $_PATH$ bit (CR3.7) determines whether the pattern is transmitted on TTIP/TRING or RPOS/RNEG. Errors can be inserted and counted in the pattern. The QRSS test mode is controlled through Control Register 3, address 0x14. Setting QGEN to 1 (CR3.1 = 1) initiates the pattern output. The QRSS pattern detector is enabled by writing a 1 to QDET (CR3.4 = 1).

When the detector synchronizes to an input pattern, QSYNC is set to 1. Errors detected in the received QRSS pattern are counted and stored in the Data Pattern Error Count, DPEC, register at address 0x15. An error can be inserted in the output data pattern by setting INS_QERR bit to 1 then 0. The number of errors accumulated by the pattern detector are stored in the DPEC register. The DPEC register will accumulate to all ones, 255 errors, and stay at that level until reset. The DPEC register is reset to zero by setting the RST_QERR bit to 1 (CR3.3 = 1)

Bits			Short Haul Mode Status
7	6	5	
0	0	0	Reset has occurred, or no program input
0	0	1	RLOOP active
0	1	0	LLOOP active
0	1	1	LOS has changed state since last Clear LOS occurred
1	0	0	TAOS active
1	0	1	Not used
1	1	0	TAOS and LLOOP active
1	1	1	Not Used

Table 5. Register 0x10 Decoding

4. ARBITRARY WAVEFORM GENERATION

In addition to the predefined pulse shapes, the user can create custom pulse shapes using the host mode. This flexibility allows the board designer to accommodate non-standard cables, EMI filters, protection circuitry, etc.

The arbitrary pulse shape of mark (a transmitted 1) is specified by describing its pulse shape across three Unit Intervals (UIs). This allows, for example, the long-haul return-to-zero tail to extend into the next UI, or two UIs, as is required for isolated pulses.

Each UI is divided into multiple phases, and the users defines the amplitude of each phase. The waveform of a space (a transmitted 0) is fixed at zero volts. Examples of the phases are shown in Figure 13. In all cases, to define an arbitrary waveform, the user writes to the Waveform Register either 36, 39 or 42 times (12, 13 or 14 phases per UI for three UIs). The phases are written in the order: UI1/phase1, UI1/phase2,..., UI1/phase14, UI2/phase1,..., UI2/phase14, UI3/phase1,..., UI3/phase14.

For E1, short haul applications the CS61581 divides the 488 ns UI into 12 uniform phases (40.7 ns each), and will ignore the phase amplitude information written for phases 13 and 14 of each UI.

For DSX-1 and DS1 applications, the CS61581 divides the 648 ns UI into 13 uniform phases (49.8 ns each), and will ignore the phase amplitude information written for phase 14 of each UI.

For E1 long haul applications, the CS61581 divides the 648 ns UI into 14 uniform phases (46.3 ns each), and uses the phase information written for all 14 phases of each UI.

When transmitting pulses, the CS61581 will add the amplitude information from the prior two symbols with the amplitude of the first UI of the current symbol before outputting a signal on TTIP/TRING.

Therefore, a mark preceded by two spaces will be output exactly as the mark is programmed. However, when one mark is preceded by marks, the first portion of the last mark may be modified. With AMI data, where successive pulses have opposite polarity, the undershoot tail of one pulse will cause the rising edge of the next mark to rise more quickly, as shown in Figure 14.

The amplitude of each phase is described by a 7-bit, two's complement number, where a positive value describes pulse amplitude, and a negative value describes pulse undershoot. The positive full value is 0x3F. The negative full value is 0x40. For T1, the typical output voltage is 38 mV/LSB. For E1 coax, the typical output voltage is 22 mV/LSB. For E1 shielded twisted pair, the typical output voltage is

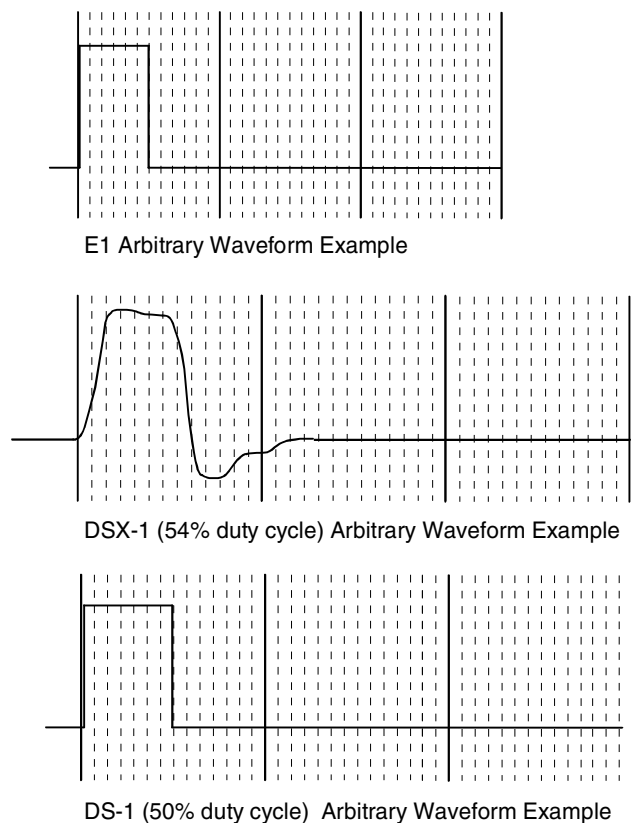

Figure 13. Phase Definition of Arbitrary Waveforms

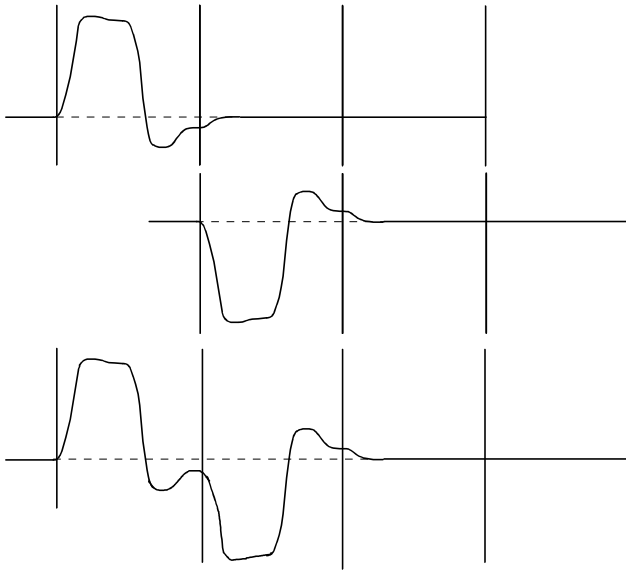

Figure 14. Example of Summing of Waveforms

27 mV/LSB. All voltages are peak voltages across the TTIP and TRING outputs.

On the secondary of a 1:2 step-up transformer, the mV/LSB is twice the values stated above. Note that although the full scale digital input is 3F, it is recommended that full scale output voltage on the transformer primary be limited to 2.4 V peak. At higher output voltages, the driver may not drive the requested output voltage.

Writing the arbitrary waveform RAM requires a deviation from normal serial port access. Register 0x13 is the RAM address register for the arbitrary waveform. Two consecutive address bytes are written; first the Address/Command Byte is written to address 0x13, followed by the address in RAM to be written. This dual address is then followed by the data byte for the waveform amplitude. There are 42 RAM byte locations (numbered 0x00 to 0x29). Each phase amplitude is written as an eight-bit byte, where the first phase of the symbol is written first. The amplitude bytes are written LSB first. Reading the Arbitrary Waveform RAM follows the same sequence as the write, except the third mem-

ory access in the sequence is a read instead of a write.

4.1 Power On Reset / Reset

Upon power-up, the IC is held in a static state until the supply crosses a threshold of approximately 3 Volts. When this threshold is crossed, the device will delay for about 10 ms to allow the power supply to reach operating voltage. After this delay, calibration of the transmit and receive sections commences. Because power up conditions can vary considerably, it is recommended that the device be reset after the power supply has stabilized to ensure a known initial operational condition.

The internal frequency generators can be calibrated only if a reference clock is present. The reference clock for the transmitter is provided by TCLK. The reference for the receiver is either the crystal oscillator or MCLK. If both the oscillator and MCLK are active, MCLK will be used as the reference source. The initial calibration should take less than 20 ms after pulses are input to the receiver.

In operation, the device is continuously calibrated, making the performance of the device independent of power supply or temperature variations. The continuous calibration function forgoes any requirement to reset the line interface when in operation. However, a reset function is available which will reinitiate calibration and clear all registers and clear the Network Loopback function.

In Host Mode, a reset is initiated by simultaneously writing RLOOP and LLOOP to the register. The reset will set all registers to “0” and initiate a calibration. A reset will also set LOS high in the Short Haul configuration.

In Hardware Mode, the CS61581 is reset by simultaneously setting RLOOP and LLOOP high for at least 200 ns. Hardware reset will clear Network Loopback functionality

4.2 Power Supply

The device operates from a single +5 Volt supply. Separate pins for transmit and receive supplies provide internal isolation. These pins should decoupled to their respective grounds. TV+ must not exceed RV+ by more than 0.3 V.

Decoupling and filtering of the power supplies is crucial for the proper operation of the analog circuits in both the transmit and receive paths. A 47 μ F

tantalum and 1.0 μ F mylar or ceramic capacitor should be connected between TV+ and TGND, and a 0.1 μ F mylar or ceramic capacitor should be connected between RV+ and RGND. Place capacitors as closely as possible to their respective power supply pins. Wire-wrap breadboarding of the line interface is not recommended because lead resistance and inductance serve to defeat the function of the decoupling capacitors.

Diagnostic Mode	Availability (Note 25)		Host Mode (Note 26)
	H/W	Host	Maskable
Loopback Modes			
Local Loopback (LLOOP)	Yes	Yes	No
Remote Loopback (RLOOP)	Yes	Yes	No
In-band Network Loopback (NLOOP)	Yes	Yes	Yes
Internal Data Pattern Generation and Detection			
Transmit All Ones (TAOS)	Yes	Yes	No
Quasi-Random Signal Source (QRSS)	No	Yes	No
In-band Loop-up/down Code Generator	No	Yes	No
Error Insertion and Detection			
Quasi-Random Signal Detection (QDET)	No	Yes	No
Quasi-Random Signal Error Insertion (INS_QERR)	No	Yes	No
Bipolar Violation Detection (BPV)	Yes	Yes	No
Alarm Condition Monitoring			
Receive Loss of Signal Monitoring (LOS)	Yes	Yes	Yes
Receive Alarm Indication Signal Monitoring (AIS)	No	Yes	Yes
Other Diagnostic Reports			
Receive Line Attenuation Indicator (LATN)	Yes	Yes	No

Notes: 25. In Hardware Mode the Diagnostic Modes are selected by directly setting the pins on the device; in Host Mode, the appropriate register bits are written for Diagnostic Modes.

26. In Host Mode the interrupts can be masked by writing a "1" to the LOS bit; there is no masking in the Hardware Mode.

Table 5. Diagnostic Mode Availability

Turns ratio: Low Impedance Output/Hardware Mode	1:2 step-up transmit, 1:1 receive
Turns ratio: Matched Impedance Output	1:1.5 step-up transmit, 1:1 receive
Primary inductance	1.2 mH min at 772 kHz
Primary leakage inductance	0.5 μ H max at 772 kHz with secondary shorted
Secondary leakage inductance	0.5 μ H max at 772 kHz
Interwinding capacitance	40 pF max, primary to secondary
ET-constant	16 V \cdot s min

Table 6. Transformer Specification

Turns Ratio(s)	Manufacturer	Part Number	Package Type
1:1CT	Pulse Engineering	PE-64936	1.5 kV, through-hole, single
	Valor	PT5008	
	Schott	67130840	
	Valor	ST5085	1.5 kV, surface mount, single
	Schott	31187	
1:2CT	Pulse Engineering	PE-65351	1.5 kV, through-hole, single
	Valor	PT5004	
	Schott	617130850	
	Valor	ST5086	1.5 kV, surface mount, single
	Schott	31188	
1:1.5CT	Pulse Engineering	T-1054	1.5 kV, through-hole, single
	Schott	31705	
	Valor	ST5074	1.5 kV, surface mount, single
	Schott	31706	
1:1CT 1:2CT	Pulse Engineering	PE-68678	1.5 kV, surface mount, dual
	Valor	ST5162	
	Pulse Engineering	PE-68877	1.5 kV, surface mount, dual extended temp.
	Pulse Engineering	T-1068	1.5 kV, surface mount, quad port
	Valor	ST5173	
	Pulse Engineering	T-1031	3 kV, surface mount, dual
	1:1CT 1:1.5CT	Pulse Engineering	T-1022
Valor		ST5221	
Pulse Engineering		T-1077	1.5 kV, surface mount, dual extended temp
Pulse Engineering		T-1081	3 kV, surface mount, dual

Table 7. Recommended Transformers for the CS61581

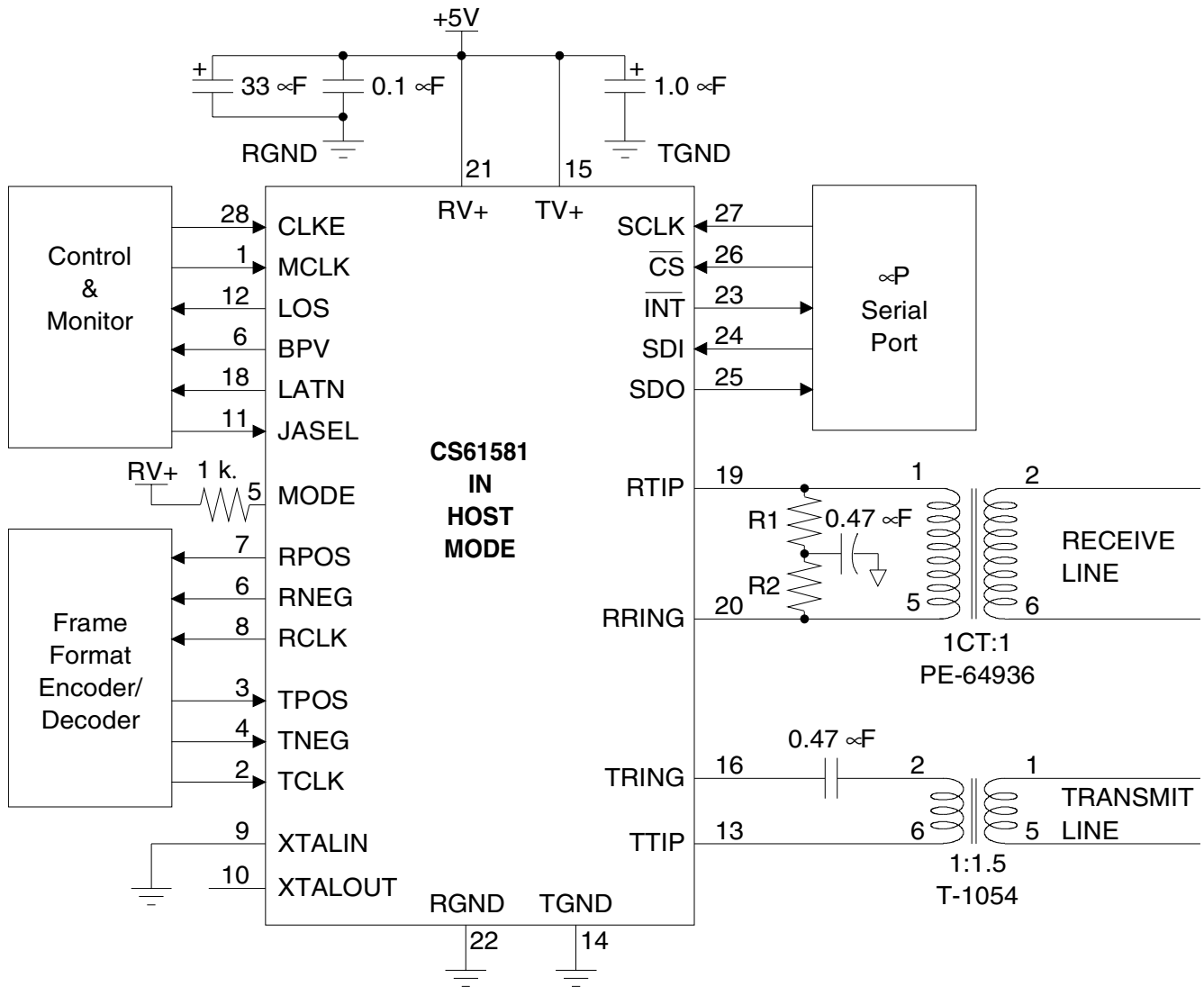
5. APPLICATIONS

	T1 100 .	E1 75 .	E1 120 .
R1 (.)	50	37.5	60
R2 (.)	50	37.5	60

Figure 15. Matched Impedance Output Configuration

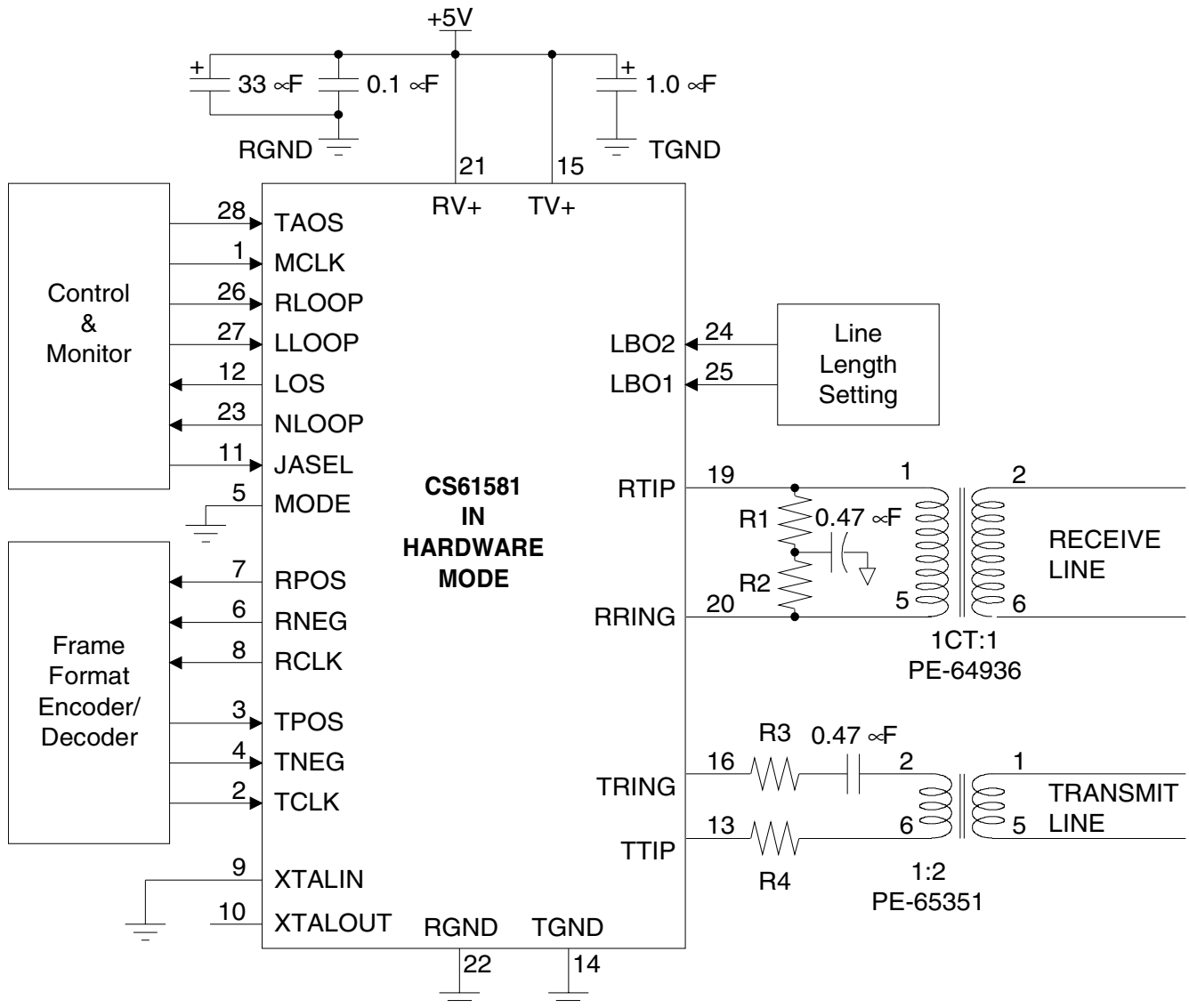

	T1 100 .	E1 75 .	E1 120 .
R1 (.)	50	37.5	60
R2 (.)	50	37.5	60
R3 (.)	9.1	9.1	9.1
R4 (.)	9.1	9.1	9.1

Figure 16. Low Impedance Output Configuration

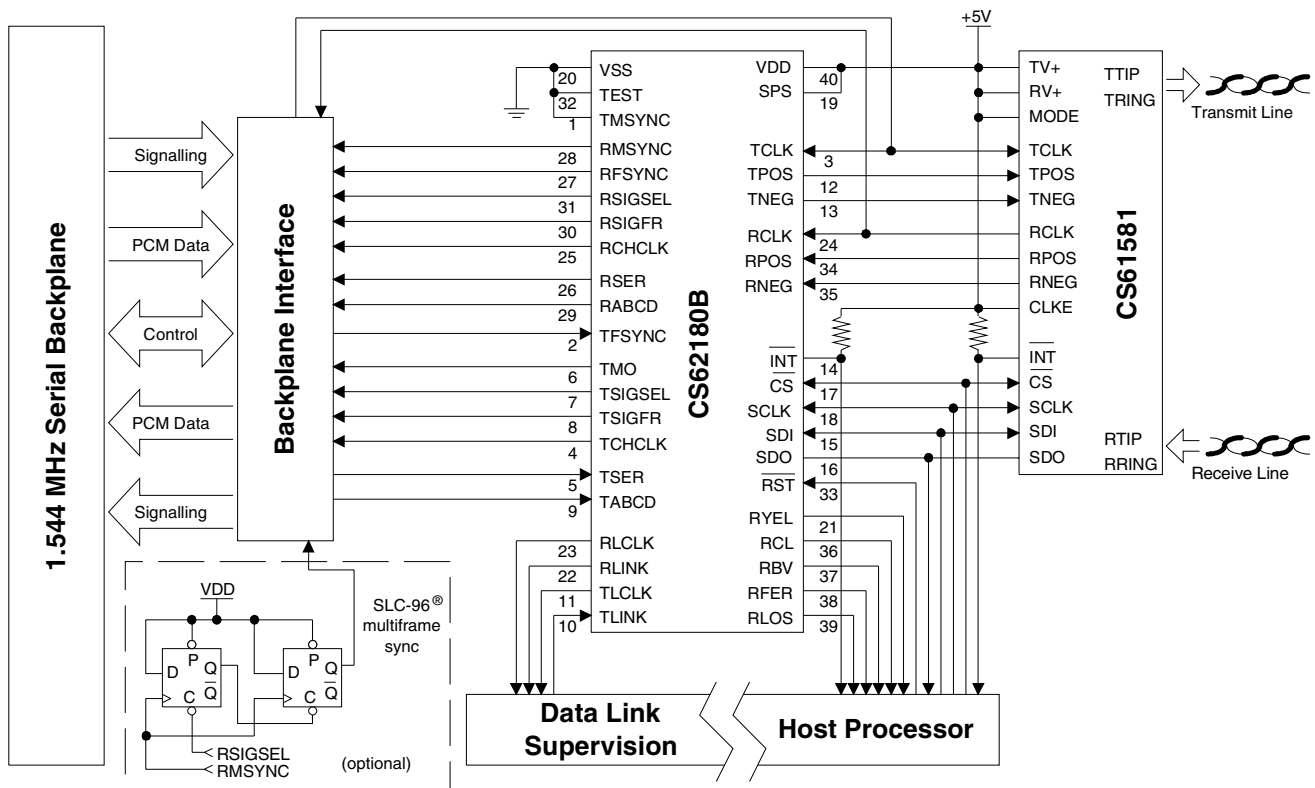
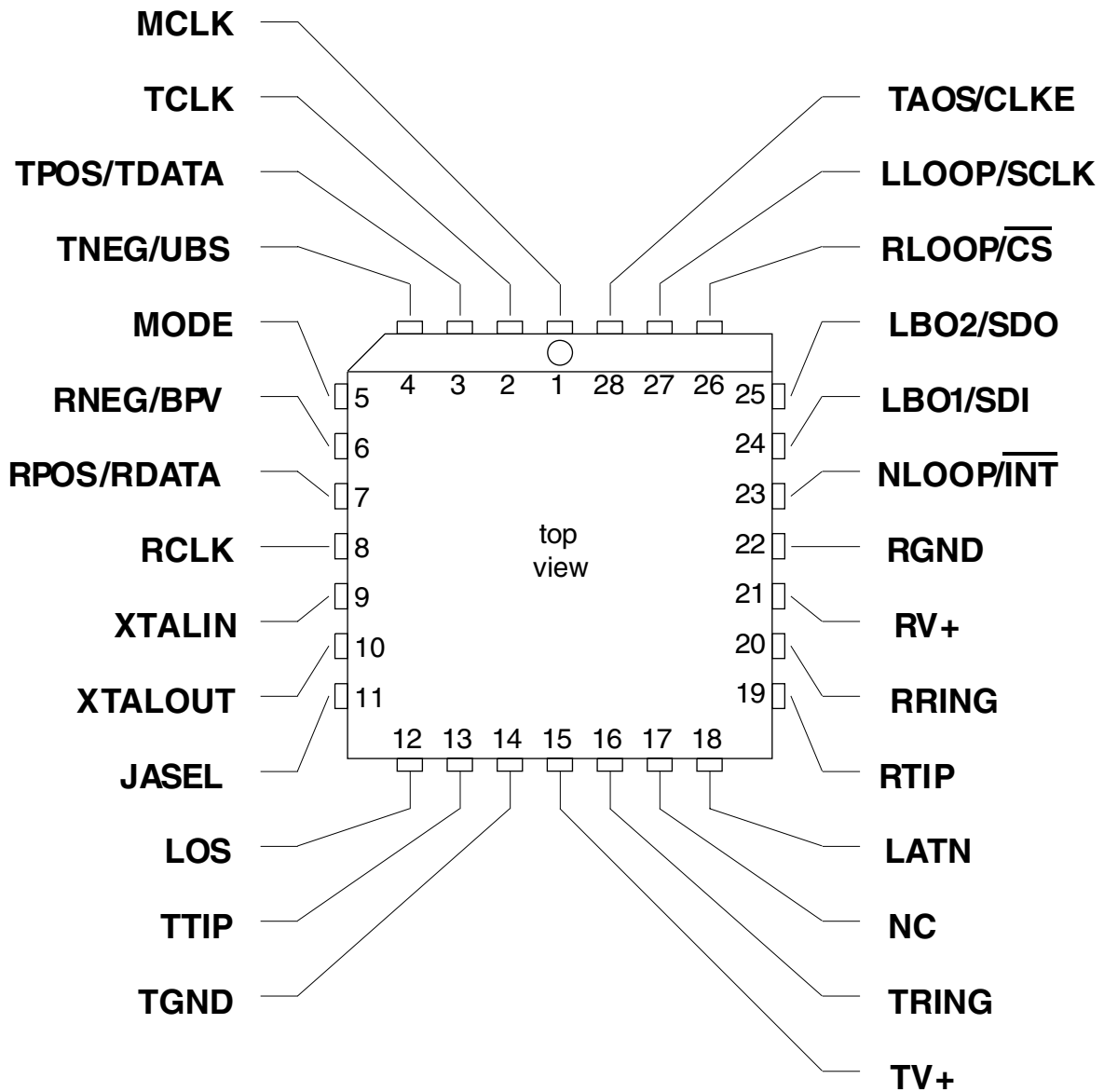

Figure 17. Typical System Connection

6. PIN DESCRIPTION

6.1 Power Supplies

TV+ - Power Supply, Transmit Driver, Pin 15.

Power supply for the transmit driver; typically +5 Volts.

TGND - Ground Transmit Driver, Pin 14.

Power supply ground for the transmit driver; typically 0 Volts.

RV+ - Power Supply, Pin 21.

Power supply for all subcircuits except the transmit driver; typically +5 Volts.

RGND - Ground, Pin 22.

Power supply ground for all subcircuits except the transmit driver; typically 0 Volts.

6.2 Oscillator

XTALIN, XTALOUT - Crystal Connections, Pins 9 and 10.

A 6.176 MHz (or 8.192 MHz) crystal can be connected across these pins. This oscillator provides the reference frequency for the LIU if MCLK is not provided. The load capacitance presented to the crystal by these pins should be approximately 19 pF (IC and package, when soldered into a circuit board). The jitter attenuator may be disabled by tying XTALIN to RV+ through a 1 k Ω resistor, and floating XTALOUT. When XTALIN has no clock input, a clock must be supplied to the MCLK pin. Alternatively an external 6.176 MHz (8.192 MHz) clock can be driven into XTALIN, and the jitter attenuator circuit will operate.

If MCLK is provided, and XTALIN is tied low or floated, the jitter attenuator will be enabled.

6.3 Control

MCLK - Master Clock Input, Pin 1.

Either MCLK or the crystal oscillator provide the master frequency reference for the CS61581. If both MCLK and the crystal oscillator are present, the oscillator is ignored. MCLK should be 1.544 MHz for T1 and 2.048 MHz for E1. In a Loss of Signal state, RCLK will be derived from MCLK, through the jitter attenuator, if active. If MCLK is not provided, the jitter attenuator will hold the RCLK frequency in a Loss of Signal state. MCLK should be grounded if it is not used.

MODE - Mode Select Input, Pin 5.

Setting the MODE pin high puts the CS61581 into Host Mode where the device is controlled by a microprocessor, via a serial port. Setting the MODE pin low, configures the part for hardware mode control where various control and status are provided on dedicated pins. The MODE pin is internally pulled down placing the part in Hardware Mode when this pin is left floating. Tying the MODE pin to RCLK places the chip in Hardware Mode and enables the B8ZS encoder/decoder (provided that unipolar mode has been enabled; see the description for TNEG/UBS pin).

TAOS - Transmit All Ones Select Input, Pin 28 (Hardware Mode).

Setting TAOS to logic 1 causes continuous ones to be transmitted at the TCLK frequency. When TAOS is high, TPOS and TNEG (TDATA) are not output at the TTIP/TRING pins. TAOS is overridden by Remote Loopback. Setting TAOS, LLOOP, and RLOOP high simultaneously enables Network Loopback detection.

LLOOP - Local Loopback Input, Pin 27 (Hardware Mode).

Setting LLOOP to a logic 1 internally routes the transmitter input to the receiver output. If TAOS is low, the signal being output from the transmitter will be internally routed to the receiver inputs allowing nearly the entire chip to be tested. If TAOS and LLOOP are set high at the same time, the local loopback will occur at the jitter attenuator (excluding the transmit and receive circuitry) and the transmitter will transmit all ones. Simultaneously setting RLOOP and LLOOP high while TAOS is low resets the CS61581. Simultaneously setting RLOOP, LLOOP and TAOS high enables Network Loopback detection.

RLOOP - Remote Loopback Input, Pin 26 (Hardware Mode).

Setting RLOOP to a logic 1 causes the received signal to be passed through the jitter attenuator (if active) and retransmitted onto the line. The internal encoders/decoders will be bypassed in Remote Loopback. Simultaneously setting RLOOP and LLOOP high while TAOS is low resets the CS61581. Simultaneously setting RLOOP, LLOOP and TAOS high enables Network Loopback detection.

LBO1, LBO2 - Line Build Out 1 and 2, Pins 24 and 25 (Hardware Mode).

Transmitted line build out pulse shapes are selected by setting LBO[2:1] = 00 (0 dB), 01 (-7.5 dB), 10 (-15 dB), or 11 (-22.5 dB).

JASEL - Jitter Attenuator Select, Pin 11.

If the jitter attenuator is enabled (crystal oscillator active, or XTALIN tied low or floated with MCLK provided), setting JASEL high places the jitter attenuator in the receive path; setting JASEL low places the jitter attenuator in the transmit path.

NC - No Connect, Pin 17.

The input voltage to this pin does not effect normal operation.

6.4 Status**LOS - Loss Of Signal Output, Pin 12.**

LOS goes high when 175 consecutive zeros are received. LOS returns low when the ones density reaches 12.5% (based on 175 consecutive bit periods, starting with a one and containing less than 100 consecutive zeros, as prescribed in ANSI T1.231-1993 and ITU-T G.775). If LOS is true, and the jitter attenuator is in the receive path, RCLK will smoothly transition to MCLK if provided; RCLK will retain the frequency prior to LOS if MCLK is grounded. If the jitter attenuator is NOT in the receive path, RCLK will become the reference clock frequency (MCLK) if provided, or the crystal oscillator.

NLOOP - Network Loopback Output, Pin 23 (Hardware Mode).

NLOOP goes high when a 00001 pattern is received for five seconds putting the CS61581 into network (remote) loopback. NLOOP is deactivated upon receipt of a 001 pattern for five seconds, or by selection of LLOOP or RLOOP.

LATN - Line Attenuation Indication Output, Pin 18.

LATN is an encoded output that indicates the receive equalizer gain setting in relation to a five RCLK cycle period. If LATN is high for one RCLK cycle, the equalizer is set for 7.5 dB gain, two cycles = 15 dB gain, three cycles = 22.5 dB gain, four cycles = 0 dB. LATN may be sampled on the rising edge of RCLK.

6.5 Serial Control Interface**INT - Interrupt Output, Pin 23 (Host Mode).**

INT pulls low to flag the host processor when NLOOP, AIS or LOS changes state. $\overline{\text{INT}}$ is an open drain output and should be tied to the supply through a resistor.

SDI - Serial Data Input, Pin 24 (Host Mode).

Data input to the on-chip register is sampled on the rising edge of SCLK.

SDO - Serial Data Output, Pin 25 (Host Mode).

Status and control information are output from the on-chip register on SDO. If CLKE is high, SDO is valid on the rising edge of SCLK. If CLKE is low, SDO is valid on the falling edge of SCLK. $\overline{\text{SDO}}$ goes to a high-impedance state when the serial port is being written to, or after bit D7 is output or $\overline{\text{CS}}$ goes high (whichever occurs first).

CS - Chip Select, Pin 26 (Host Mode).

The serial interface is accessible when $\overline{\text{CS}}$ transitions from high to low.

SCLK - Serial Clock Input, Pin 27 (Host Mode).

SCLK is used to write or read data bits to or from the serial port registers.

CLKE - Clock Edge, Pin 28 (Host Mode).

Setting CLKE to logic 1 causes RPOS and RNEG (RDATA) to be valid on the falling edge of RCLK, and SDO to be valid on the rising edge of SCLK. Conversely, setting CLKE to logic 0 causes RPOS and RNEG (RDATA) to be valid on the rising edge of RCLK and SDO to be valid on the falling edge of SCLK.

6.6 Data Input/Output

TCLK - Transmit Clock Input, Pin 2.

The 1.544 MHz (2.048 MHz) transmit clock is input on this pin. TPOS and TNEG or TDATA are sampled on the falling edge of TCLK.

TPOS/TNEG - Transmit Positive Pulse, Transmit Negative Pulse, Pins 3 and 4.

Data input to TPOS and TNEG is sampled on the falling edge of TCLK and transmitted onto the line at TTIP and TRING. An input on TPOS results in transmission of a positive pulse; an input on TNEG results in transmission of a negative pulse. If TNEG is held high for 16 TCLK cycles, the CS61581 reconfigures for unipolar (single pin NRZ) data at pins 3 and 7, TDATA and RDATA. If TNEG goes low the CS61581 switches back to two-pin bipolar data input format. The device should be reset when changing between unipolar and bipolar mode.

TDATA - Transmit Data, Pin 3.

When pin 4, TNEG/UBS, is held high, pin 3 becomes TDATA, a single-line NRZ (unipolar) data input sampled on the falling edge of TCLK.

UBS - Unipolar / Bipolar Select, Pin 4.

When UBS is held high for 16 consecutive TCLK cycles (15 consecutive bipolar violations) the CS61581 reconfigures for unipolar (single-line NRZ) data input / output format. Pin 3 becomes TDATA, pin 7 becomes RDATA, and pin 6 becomes BPV.

RCLK - Recovered Clock Output, Pin 8.

RCLK outputs the clock recovered from the input signal at RTIP and RRING. In a Loss of Signal state RCLK reverts to the MCLK frequency, or retains the frequency prior to the LOS state, depending on the clocks provided. See the LOS pin description.

RNEG/RPOS - Receive Negative Pulse, Receive Positive Pulse, Pins 6 and 7.

Recovered data output on RPOS and RNEG is stable and valid on the rising edge of RCLK in Hardware Mode. In Host Mode, CLKE determines the edge of RCLK on which RPOS and RNEG are valid. A positive pulse on RTIP with respect to RRING generates a logic 1 on RPOS; a positive pulse on RRING with respect to RTIP generates a logic 1 on RNEG.

RDATA - Received Data, Pin 7.

Unipolar data (single-line NRZ) data is output on RDATA when TNEG/UBS (pin 4), is held high. In Host Mode, CLKE determines the edge of RCLK on which RDATA is valid.

BPV - Bipolar Violation, Pin 6.

When pin 4 is held high, received bipolar violations are flagged by BPV (RNEG) going high along with the offending bit output from RDATA. If the B8ZS or HDB3 encoder/decoder is activated, BPV will not flag bipolar violations resulting from valid zero substitutions.

TTIP, TRING - Transmit Tip and Ring, Pins 13, 16.

The transmit signal to the line is sent out on these pins. They represent the signal driven on TCLK, TPOS, and TNEG (or TDATA).

RTIP, RRING - Receive Tip and Ring, Pins 19, 20.

The input pins for the receive signal from the line. They recovered clock and data driven on RCLK, RPOS, and RNEG (or RDATA).

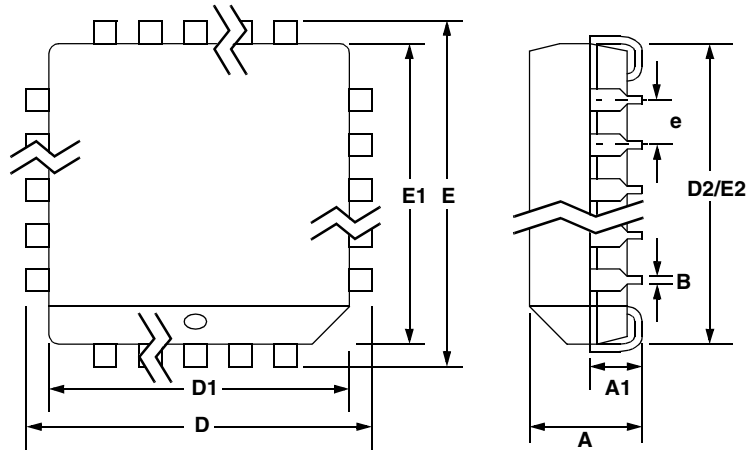
28L PLCC PACKAGE DRAWING

DIM	INCHES			MILLIMETERS		
	MIN	NOM	MAX	MIN	NOM	MAX
A	0.165	0.1725	0.180	4.191	4.3815	4.572
A1	0.090	0.105	0.120	2.286	2.667	3.048
B	0.013	0.017	0.021	0.3302	0.4318	0.533
D	0.485	0.490	0.495	12.319	12.446	12.573
D1	0.450	0.453	0.456	11.430	11.506	11.582
D2	0.390	0.410	0.430	9.906	10.414	10.922
E	0.485	0.490	0.495	12.319	12.446	12.573
E1	0.450	0.453	0.456	11.430	11.506	11.582
E2	0.390	0.410	0.430	9.906	10.414	10.922
e	0.040	0.050	0.060	1.016	1.270	1.524

JEDEC # : MS-047

Revision	Date	Changes
PP8	April '00	Preliminary release.
F1	Aug '05	Removed 28-pin PDIP package option.

Contacting Cirrus Logic Support

For all product questions and inquiries contact a Cirrus Logic Sales Representative.

To find the one nearest to you go to www.cirrus.com

IMPORTANT NOTICE

Cirrus Logic, Inc. and its subsidiaries ("Cirrus") believe that the information contained in this document is accurate and reliable. However, the information is subject to change without notice and is provided "AS IS" without warranty of any kind (express or implied). Customers are advised to obtain the latest version of relevant information to verify, before placing orders, that information being relied on is current and complete. All products are sold subject to the terms and conditions of sale supplied at the time of order acknowledgment, including those pertaining to warranty, indemnification, and limitation of liability. No responsibility is assumed by Cirrus for the use of this information, including use of this information as the basis for manufacture or sale of any items, or for infringement of patents or other rights of third parties. This document is the property of Cirrus and by furnishing this information, Cirrus grants no license, express or implied under any patents, mask work rights, copyrights, trademarks, trade secrets or other intellectual property rights. Cirrus owns the copyrights associated with the information contained herein and gives consent for copies to be made of the information only for use within your organization with respect to Cirrus integrated circuits or other products of Cirrus. This consent does not extend to other copying such as copying for general distribution, advertising or promotional purposes, or for creating any work for resale.

CERTAIN APPLICATIONS USING SEMICONDUCTOR PRODUCTS MAY INVOLVE POTENTIAL RISKS OF DEATH, PERSONAL INJURY, OR SEVERE PROPERTY OR ENVIRONMENTAL DAMAGE ("CRITICAL APPLICATIONS"). CIRRUS PRODUCTS ARE NOT DESIGNED, AUTHORIZED OR WARRANTED FOR USE IN AIRCRAFT SYSTEMS, MILITARY APPLICATIONS, PRODUCTS SURGICALLY IMPLANTED INTO THE BODY, AUTOMOTIVE SAFETY OR SECURITY DEVICES, LIFE SUPPORT PRODUCTS OR OTHER CRITICAL APPLICATIONS. INCLUSION OF CIRRUS PRODUCTS IN SUCH APPLICATIONS IS UNDERSTOOD TO BE FULLY AT THE CUSTOMER'S RISK AND CIRRUS DISCLAIMS AND MAKES NO WARRANTY, EXPRESS, STATUTORY OR IMPLIED, INCLUDING THE IMPLIED WARRANTIES OF MERCHANTABILITY AND FITNESS FOR PARTICULAR PURPOSE, WITH REGARD TO ANY CIRRUS PRODUCT THAT IS USED IN SUCH A MANNER. IF THE CUSTOMER OR CUSTOMER'S CUSTOMER USES OR PERMITS THE USE OF CIRRUS PRODUCTS IN CRITICAL APPLICATIONS, CUSTOMER AGREES, BY SUCH USE, TO FULLY INDEMNIFY CIRRUS, ITS OFFICERS, DIRECTORS, EMPLOYEES, DISTRIBUTORS AND OTHER AGENTS FROM ANY AND ALL LIABILITY, INCLUDING ATTORNEYS' FEES AND COSTS, THAT MAY RESULT FROM OR ARISE IN CONNECTION WITH THESE USES.

Cirrus Logic, Cirrus, and the Cirrus Logic logo designs are trademarks of Cirrus Logic, Inc. All other brand and product names in this document may be trademarks or service marks of their respective owners.