

CT2553 / 2554 / 2555 / 2556

Advanced Integrated MUX (AIM) Hybrid

FOR MIL-STD-1553

Features

- **Second Source Compatible to the BUS-61553**
- **Complete Integrated MUX Including:**
 - Low Power Dual Transceiver
 - BC/RTU/MT Protocol
 - 8K x 16 Shared Ram
 - Interrupt Logic
- **Compatible with MIL-STD- 1750 and other Standard CPUs**
- **DIP or Flatpack Hybrid**
- **Minimizes CPU Overhead**
- **Provides Memory Mapped 1553 Interface**
- **On-Line & Off-Line Self-Test**
- **PCs Development Tools Available**
- **SEAFAC Tested**
- **MIL-PRF-38534 compliant circuits available**
- **DESC SMD #5962–88692 Pending**
- **Packaging – Hermetic Metal**
 - 78 Pin, 2.1" x 1.87" x .25" Plug-In type package
 - 82 Lead, 2.2" x 1.61" x .18" Flat package



General Description

Aeroflex's CT2553 Advanced Integrated Mux (AIM) Hybrid is a complete MIL-STD-1553 Bus Controller (BC), Remote Terminal Unit (RTU), and Bus Monitor (MT) device. Packaged in a single 78 pin DIP package, the CT2553 contains dual low-power transceivers, complete BC/RTU/MT protocol logic, a MIL-STD-1553-to-host interface unit and an 8K x 16 RAM.

Using an industry standard dual transceiver and standard status and control signals, the CT2553 simplifies system integration at both the MIL-STD-1553 and host processor interface levels.

All 1553 operations are controlled through the CPU access to the shared 8K x 16 RAM. To ensure maximum design flexibility, memory control lines are provided for attaching external RAM to the CT2553 Address and Data Buses and for disabling internal memory; the total combined memory space can be expanded to 64K x16. All 1553 transfers are entirely memory-mapped; thus the CPU interface requires minimal hardware and/or software support.

The CT2553 operates over the full military -55°C to +125°C temperature range. Available screened to MIL-STD883, the CT2553 is ideal for demanding military and industrial microprocessor to 1553 interface applications. See "Ordering Information" (last sheet) for CT2554, CT2555 & CT2556.

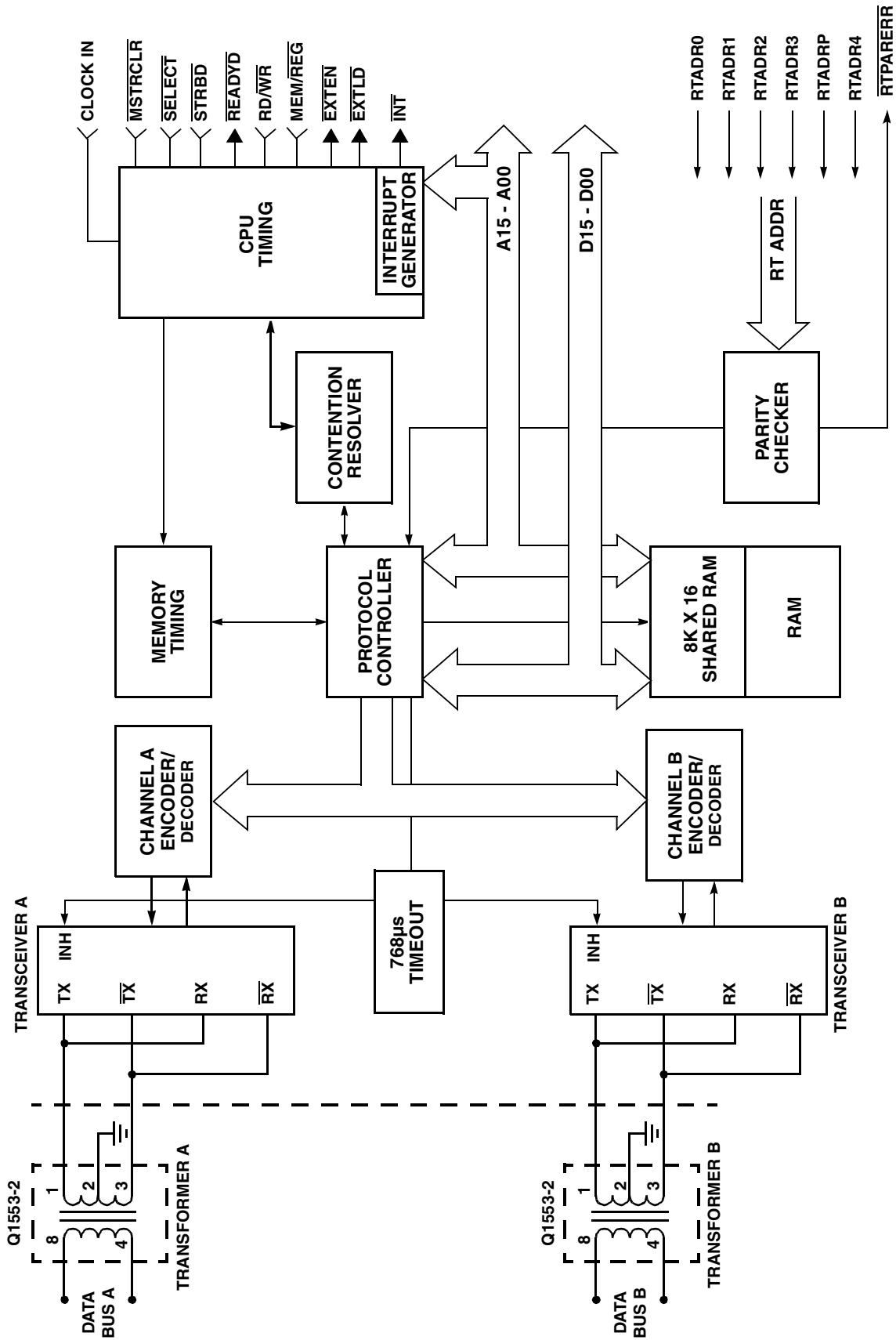

Note: The Watch-Dog Time Out (768µs TYP) is built in.

Figure 1 – CT2553 Block Diagram

Values at nominal Power Supply Voltages unless otherwise specified

PARAMETER	VALUE	UNITS
Receiver		
Differential Input Voltage	40 max	Vp-p
Differential Input Impedance	7 min	KΩ
CMRR	40 min	db
Transmitter (Direct Coupled)		
Differential Output Voltage	6.0 min, 9.0 max	Vp-p
Output Rise and Fall Times	100 min, 300 max	nsec
Output Offset Voltage	±90 max	mV
Logic*		
V _{IH}	2.2 min	V
V _{IL}	0.8 max	V
Clock	16	MHZ
Power Supplies		
+5V (Logic)	+5±5%	V
-15VA (Channel A Transceiver)	-15±10%	V
-15VB (Channel B Transceiver)	-15±10%	V
+5VA (Channel A)	+5±5%	V
+5VB (Channel B)	+5±5%	V
Current Drain* (Total Package)	(TYP)/max	
+5V (Idle)	(85)/170	mA
-15V (Idle)	(45)/80	mA
+5V (25% Duty Cycle)	(85)/170	mA
-15V (25% Duty Cycle)	(80)/130	mA
Temperature Range		
Operating (Case)	-55 to +125	°C
Storage	-65 to +150	°C
Physical Characteristics		
Size		
78 pin DDIP	2.1 x 1.87 x 0.25 (53 x 47.5 x 6.4)	in (mm)
82 pin flatpack	2.19 x 1.6 x 0.175 (55.6 x 40.6 x 4.34)	in (mm)

* See Table 7 for pin loading characteristics.

Table 1 – CT2553 Specifications

GENERAL

The CT2553 is a complete MIL-STD-1553 bus interface unit containing dual low-power transceivers; Bus Controller (BC), Remote Terminal (RTU), and Bus Monitor (MT) protocol logic; 8K x 16-bit pseudo dual port RAM; and memory management arbitration control circuitry. The host processor interface consists of standard control and interrupt signals, memory expansion capability and non-multiplexed address and data buses.

Control of the CT2553 is accomplished entirely through the use of three internal registers and the

shared RAM. Transfers to and from the CT2553 are executed on a word-by-word basis ensuring minimal wait time if contention occurs.

The specific mods of operation (1553 BC/RTU/MT) is software programmable. Memory is configured into unique control and data block areas based on the 1553 mode of operation. External registers are also supported by the CT2553 for manipulation of user data. In addition, the CT2553 provides dynamic, online and software initiated self-test capabilities.

INTERFACING

The CT2553 is compatible with most common microprocessors including, but not limited to, the Motorola 680 x 0, the Intel 808x, Zilog Z800x and MIL-STD-1750 processors.

Interfacing the CT2553 to the MIL-STD-1553 Data Bus requires two Q1553-2 pulse transformers and an external 16 MHz clock (See Figure 2). Tri-state buffers are used to isolate the CPU's data and address lines.

External RAM can be used instead of or in conjunction with the CT2553's internal 8K x 16 bits. The external RAM used by the CT2553 can be any standard static memory with an access time of ≤ 55 ns. The external RAM can be expanded to 64K x 16.

Two control signals, MEMENA-IN (pin 69) and MEMENMA-OUT (pin 31) are provided in addition to the standard memory I/O signals for internal/external memory access control (See Figures 3-5. MEMEN-OUT and MEMEN-IN should be tied together for Internal Memory Only configuration. Memory CS signals can be generated for configurations using external memory.

MEMORY MANAGEMENT

Memory can be configured to support two AREAs (A and B), each with an independent sequential stack and pointers for manipulating 1553 message and control data. The CPU can access the shared RAM while 1553 message transfers are taking place. Arbitration of the RAM is automatically implemented in a manner transparent to the subsystem (See Figures 28-31). Variable Length DATA BLOCKS are also stored in the shared RAM and can be addressed by setting pointers residing in Area A, Area B or both.

For BC/RTU operation, each area contains a Descriptor Stack and Stack Pointer (See Figures 6 and 7). BC operation further maintains a Message Count for each area (number of 1553 messages per frame). RTU operation maintains a data block address Look-Up Table for each area. MT operation utilizes a single Stack Pointer to indicate the starting address for storage of received words and associated identification Words.

CURRENT AREA ASSIGNMENT/SWAPPING.

Current area status (currently available to the 1553 terminal) is Software programmable by the host; the unassigned area automatically assumes non-current area status. Both areas are always addressable by the host. Swapping of the Current Area can be done following message transfers for user operations such as exception handling or multiple buffering of 1553 data.

The host selects the Current Area by writing to the CT2553's Configuration Register with bit 13

set to the appropriate logic level (0 for area A or 1 for area B). Internal circuitry ensures that the swapping of Current Area Status does not occur during an ongoing message transfer (See Configuration Register).

DESCRIPTOR STACK (BC/RTU). The DESCRIPTOR STACK (DS) is divided into 64 entries. Each stack entry contains four words which refer to one 1553 message. The Block Status Word (BSW) indicates the physical bus on which the message was received (RTU mode), reports whether or not an error was detected during message transfer and indicates message completion (See Figure 8).

The user-supplied Time Tag word is loaded at the start of a message transfer and is updated at the end of the transfer (See Time Tagging).

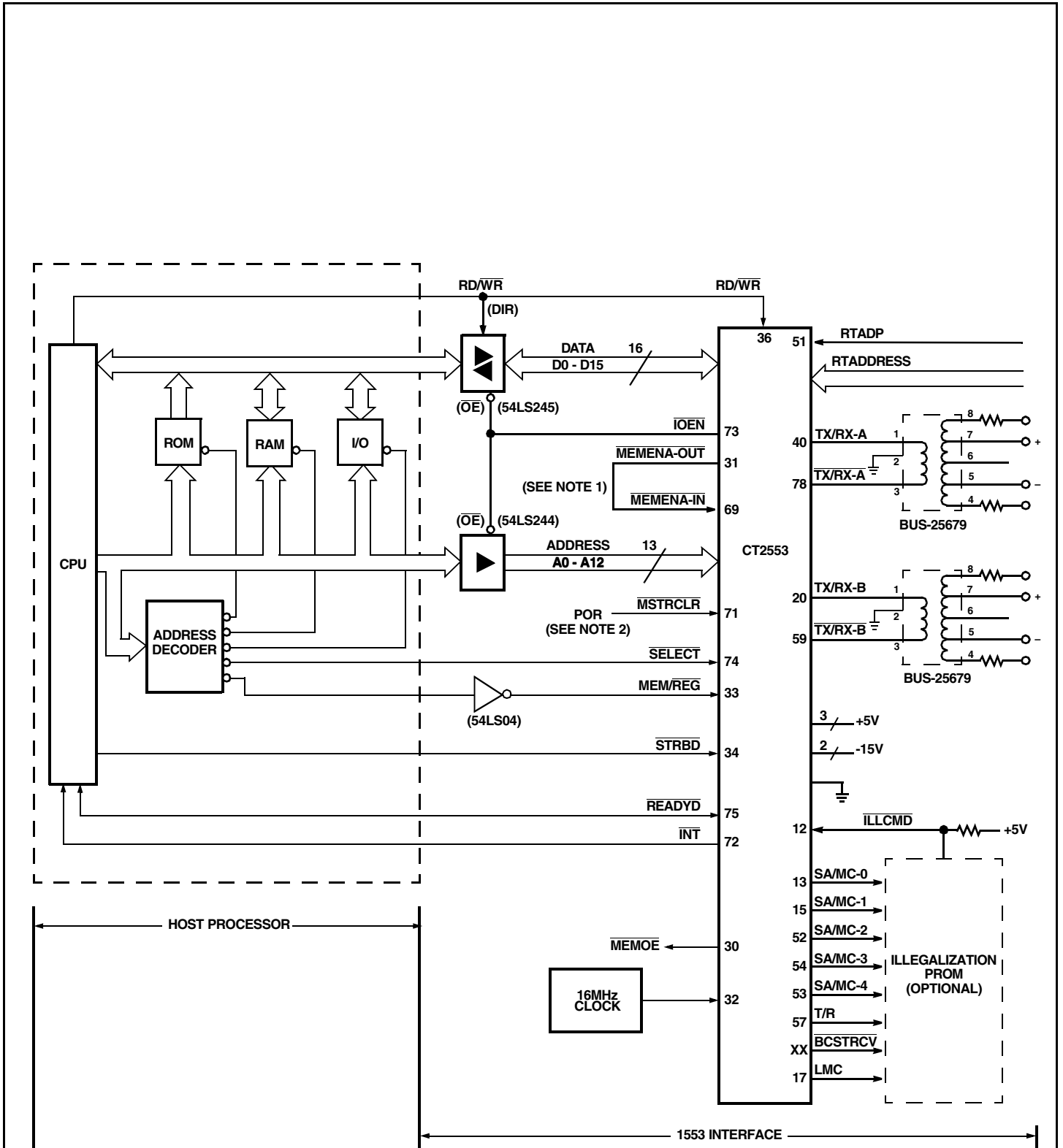

Figure 2 – CT2553 Example Interconnection

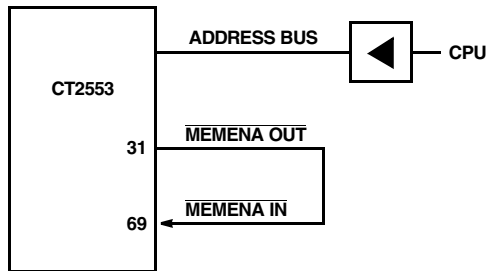

Figure 3 – Internal Memory Only

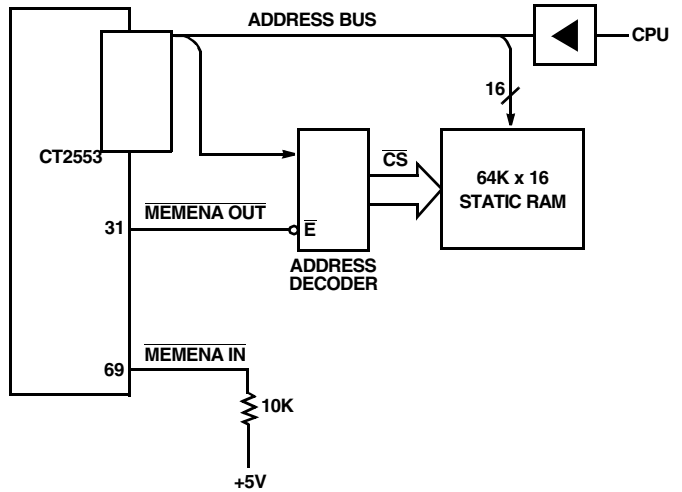

Figure 4 – External Memory Only

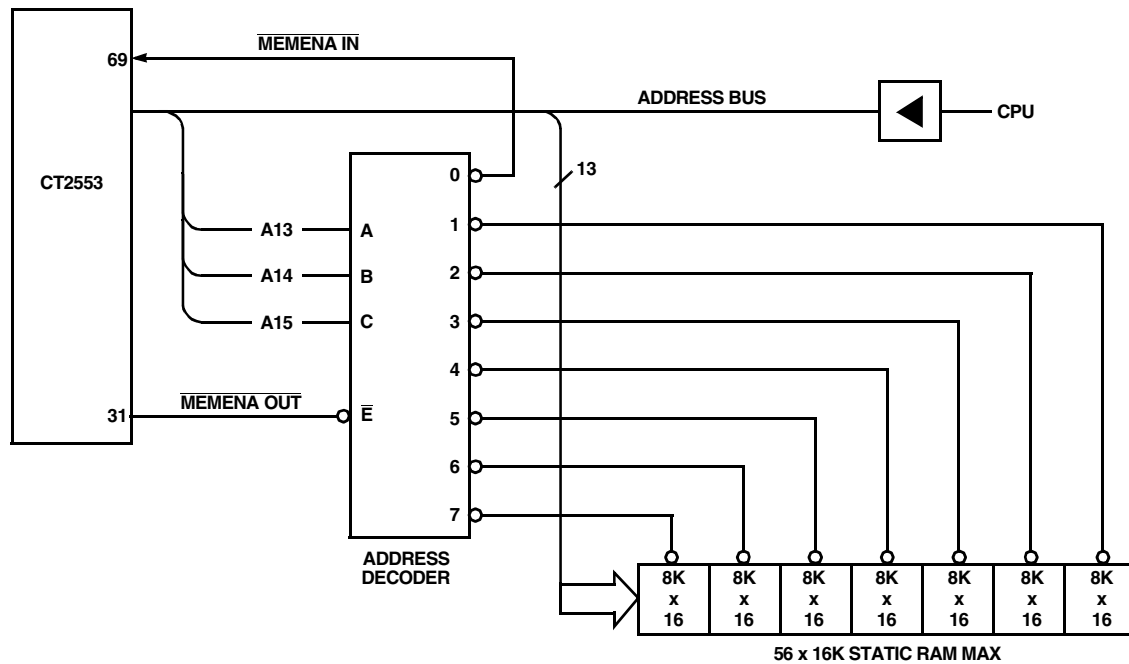
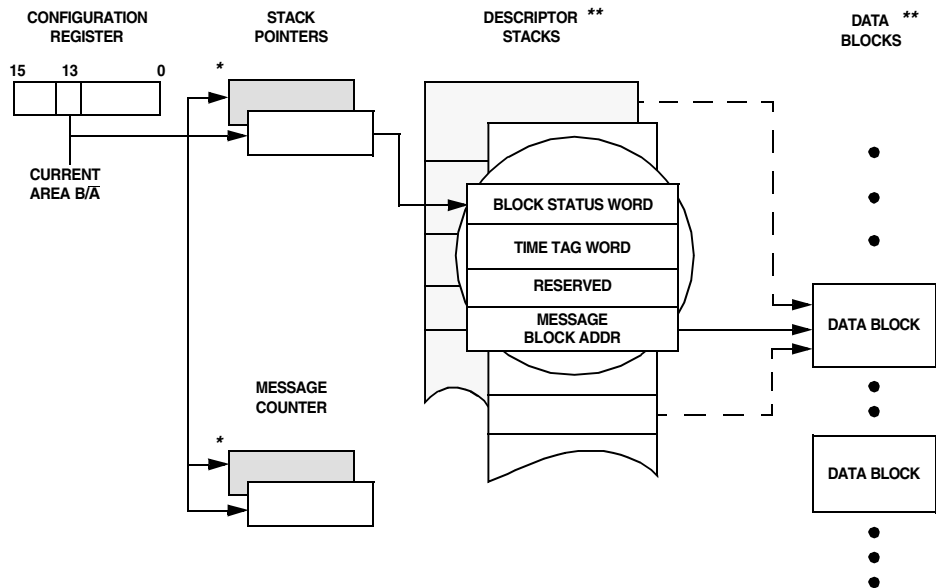

Figure 5 – Configuration Using Both Internal and External Memory



* Note:
STACK POINTERS and MESSAGE COUNTERS are switched via the CONFIGURATION REGISTER under external CPU control.

** Note:
DESCRIPTOR STACKS and DATA BLOCKS have 256 word boundaries which should be observed.

Figure 6 – Use of Descriptor Stack – BC Mode

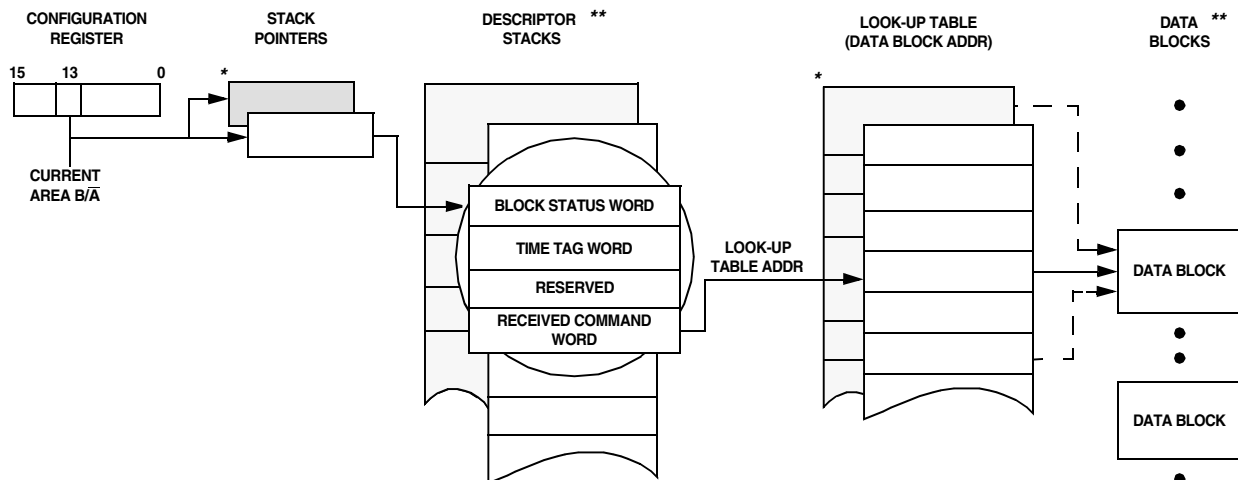

* Note:
STACK POINTERS and LOOK-UP TABLE are switched via the CONFIGURATION REGISTER under external CPU control.

** Note:
DESCRIPTOR STACKS and DATA BLOCKS have 256 word boundaries which should be observed.

Figure 7 – Use of Descriptor Stack – RTU Mode

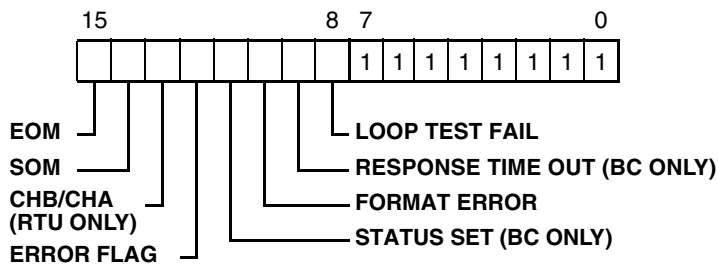

Note: In BC operation, the CT2553 always writes the BSW to RAM with Bit-13. CHB/CHA toggles as per the message control word setting.

BIT NAME	DEFINITION
EOM	Set at the completion of a message transfer regardless of whether any errors were detected.
SOM	Set at the beginning of a message transfer and Reset upon completion of the transfer.
CHB/ $\overline{\text{CHA}}$	Set in RTU mode to indicate whether the message was received on 1553 bus A or bus B. Toggles to indicate channel, in BC mode.
ERROR FLAG	Indicates that an error was detected within the message transfer. The specific error condition(s) are identified in bits 8-11.
STATUS SET	Set in BC mode to indicate that a status flag bit was set within the received RTU Status Word or that the RTU address did not match the associated Command. Set in BC mode when the message error bit is set within the received RTU Status Word.
FORMAT ERROR	Also set in RTU mode (RT-RT transfer; CT2553 is acting as the receiving RT) when the transmitting RTU Status Word contains an incorrect address. Also, set in BC or RTU mode if the message violates MIL-STD-1553 (parity, Manchester, sync bit count, non-contiguous data or word count errors).
RESPONSE TIMEOUT	Set in BC mode if the addressed RTU did not respond within 14 μ s. Also set when acting as a receiving RT (RT-RT transfer) if the transmitting RT does not respond in the specified 1553 response time.
LOOP TEST FAIL	Set when the CT2553 does not pass the Loop Test. See Self Test paragraph.

Figure 8 – Descriptor Stack - Block Status Word

The contents of the fourth word of the stack entry depends upon the 1553 operating mode selected. In BC mode, It contains the address of the associated 1553 message (Data Block). In RTU mode, it contains the complete (received) 1553 Command Word.

STACK POINTER. A STACK POINTER (SP) is maintained at a specified location in shared RAM for each Descriptor Stack (SP-A: 0100H; SP-B: 0104H). Each Stack Pointer must be initialized by the CPU to point to the Descriptor Stack Entry to be used for the first MIL-STD-1553 transmission. The current area SP is automatically incremented by four following each message transfer thereby always pointing to the next Block Status Word.

Note: The Stack Pointer is maintained internally using an 8-BIT REGISTER for the HIGH BYTE and an 8-BIT COUNTER for the LOW BYTE. The high byte remains constant (user value) while the low byte will wrap around from FF(H) to 00(H). For example: a current Stack Pointer value of 00 FF(H) will increment to 00 00(H) and not 01 00 (H).

LOOK-UP TABLE (RTU). A data block address Look-Up Table is used to indicate the data blocks to be used for individual commands. Look-Up is based upon the T/ $\overline{\text{R}}$ (transmit/receive) and Subaddress bits of the received 1553 Command Word. See RTU Operation for detailed operation; two tables are provided for double buffering in the RTU mode.

MULTIPLE BUFFERING (BC/RTU). Unused areas of shared RAM can be used to store additional stacks, tables, data blocks and/or user (non 1553-related) data. In this way, multiple data blocks (RTU) or messages (BC) can be stored for later use: simply update respective pointers and initiate the appropriate start conditions. (BC mode requires SP, message block address and message count updating while in RTU mode, the SP and Look-Up Table entry must be updated).

CT2553 REGISTERS

The CT2553 is controlled through the use of three internal registers: Interrupt Mask Register, Configuration Register and a Start/Reset Register. In addition, the CT2553 can access up to four external, user supplied registers (See Table 2). Possible external register applications include: CPU Time Tag storage and RTU Address assignment (See Figures 9 and 10).

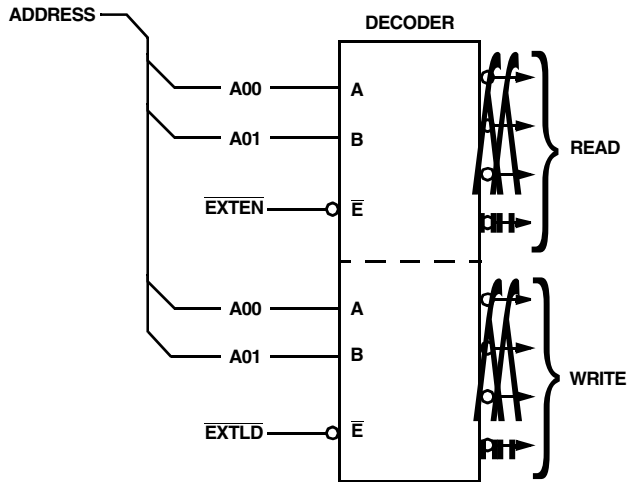

Note:
A02 of the CT2553 must be set to logic 1 to operate with external registers.

Figure 9 – Use of External Registers

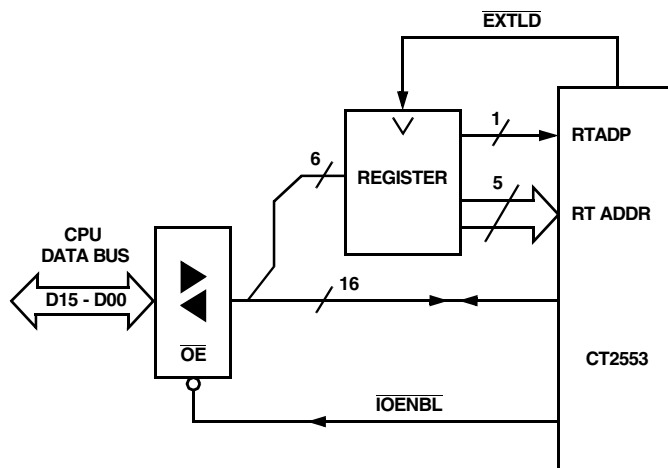
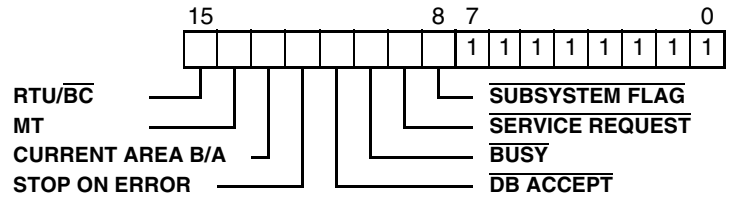

Figure 10 – Example Configuration Using External Registers

CPU TO REGISTER OPERATIONS. The CPU selects a register by asserting MEM/REG low and A2 to a logic 0 (for internal registers) or logic 1 (for external registers) with A0 and A1 indicating the appropriate register address (See Figures 28-32). The signals EXTEN and EXTLD are used to access the external registers.

CONFIGURATION REGISTER. The Configuration Register is a 16-bit read/write register used to define the 1553 operating mode (BC, RTU, or MT); define selectable 1553 Status Word bits (RTU only); select stop-on-error option; and support the double buffering scheme (See Figure 11).



BIT NAME	DEFINITION															
SUBSYSTEM FLAG	Sets/resets 1553 Status Word flag.															
SERVICE REQUEST	Sets/resets 1553 Status Word flag.															
BUSY	Sets/resets 1553 Status Word flag.															
DB ACCEPT	Sets/resets 1553 Status Word flag.															
STOP ON ERROR	BC will halt message transfer after completing current EOM cycle.															
CURRENT AREA B/A	Selects Current Area Pointers.															
RTU/BC	RTU or BC-MT Operation Select.															
	<table border="1"> <thead> <tr> <th>BIT15</th> <th>BIT 14</th> <th>Operation</th> </tr> </thead> <tbody> <tr> <td>0</td> <td>0</td> <td>BC</td> </tr> <tr> <td>0</td> <td>1</td> <td>MT</td> </tr> <tr> <td>1</td> <td>0</td> <td>RTU</td> </tr> <tr> <td>1</td> <td>1</td> <td>Illegal</td> </tr> </tbody> </table>	BIT15	BIT 14	Operation	0	0	BC	0	1	MT	1	0	RTU	1	1	Illegal
BIT15	BIT 14	Operation														
0	0	BC														
0	1	MT														
1	0	RTU														
1	1	Illegal														

Note: A logic 0 causes the corresponding bit within the RTU's status word to be set to a logic 1.

Figure 11 – Configuration Register

INTERRUPT MASK REGISTER (BC/RTU). This register is a 16-bit read/write register used to enable/mask interrupt conditions. If an interrupt condition occurs and the corresponding Interrupt Register bit has been enabled (set to logic 1) pin 72, INT will be pulsed low during the respective End of Message (EOM) cycle (See Figure 12). Not Used bit locations can optionally be used for storing user flags.

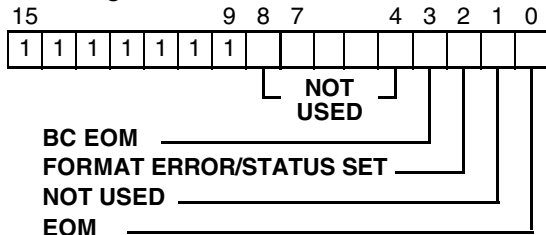

INTERRUPT	DEFINITION
EOM	End of message. Set by CT2553 in BC or RTU mode following each 1553 transfer (regardless of validity).
FORMAT ERROR/STATUS SET	Set if one of the following occurs: Loop Test Failure: Received word does not match last word transmitted. Message Error: Received message contained a violation of any of the 1553 message validation criteria (parity, sync, manchester encoding, bit/word count, etc.) Time-Out: Expected transmission was not received during the allotted time. Status Set: Received Status Word contained status bit(s) set or address error.
BC EOM	Bus Controller End of Message. Set by the CT2553 following transmission of all messages within the current Message Block (Current area message count = FFFF).

Figure 12 – Interrupt Mask Register

START/RESET REGISTER. This write-only register is used to reset the CT2553 and to start the BC and MT operations, as illustrated in Figure 13.

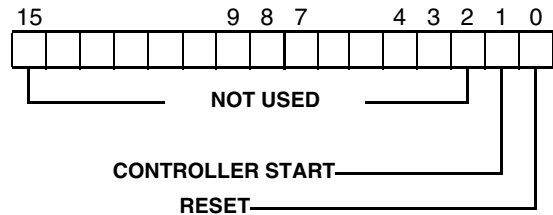

	BIT 1	BIT 0
START	1	0
RESET	0	1

BIT NAME	DEFINITION
CONTROLLER START	Issued by the CPU to start message block transmission (BC Operation) or to begin reception of 1553 messages (MT Operation).
RESET	Issued by the CPU to place the CT2553 in the power-on condition; (1) aborts 1553 transfers currently in progress, and (2) resets Configuration and Interrupt Mask Register bits (logic 0).

Figure 13 – Start/Reset Register

Table 2 – CT2553 Register Address Definition

Address Bits			Definition	
A2	A1	A0		
0	0	0	R/W	Interrupt Mask Register
0	0	1	R/W	Configuration Register
0	1	0	–	Not Used
0	1	1	W	Start/Reset Register
1	0	0	R/W	* External Register
1	0	1	R/W	* External Register
1	1	0	R/W	* External Register
1	1	1	R/W	* External Register

* Note: R/W (read/write) capability is dependent on the user's decoding implementation (See Figure 9).

CONTENTION HANDLING

The CT2553 arbitrates shared RAM (and control register) accesses between the host CPU and the internal 1553 protocol logic.

If the host attempts to access the RAM while an internal 1553 memory cycle is in progress, the CT1553 will delay the CPU's memory cycle by inserting wait states via the READYD control signal until the cycle has been completed. The maximum delay is 1.8µs.

If the internal 1553 protocol logic attempts to access the RAM while the host CPU has control of the memory, the internal 1553 logic will wait until the host CPU cycle has been completed. To ensure the integrity of 1553 data transfers, the host CPU must complete its memory cycle within 1.5µs (See Figures 28-32).

SELF TEST

The CT2553 has two self-test modes: the automatic, continuous On-Line test and the software-initiated Off-Line test. In both tests the Loop Test Fail bit within the Block Status Word will be set to a logic 1 if a failure is detected.

ON-LINE TEST. The On-Line test occurs in BC and RTU modes during transmission of each message onto the 1553 bus. This test wraps around the last word transmitted, exercising the 1553 protocol logic through the 1553 transceivers. While operating as a BC, the last word transmitted is received, decoded, and written back into memory location immediately following the last word within the message block. The host CPU can read and compare this Loop Back Word with the last word of the message Data Block; these two words should be identical. This insures data integrity between the CPU and the CT2553.

While in the RTU mode, the internal 1553 Status Word will be updated to reflect the result of the self test. The Status Word's Terminal Flag bit will be set to a logic 1 if a fault was indicated by the wrap-around, self-test.

OFF-LINE TEST. The software-initiated Off-Line test can be executed only when the CT2553 is

configured as a BC. Set the Wrap-Around Test bit within the BC Control Word to a logic 1 and initiate any standard message transfer. This inhibits the 1553 transceivers and initiates the standard wrap-around test (i.e., internal 1553 encoder output is fed back into the decoder - the word is then written into memory). See BC Operation and Figure 14, BC Control Word for more details.

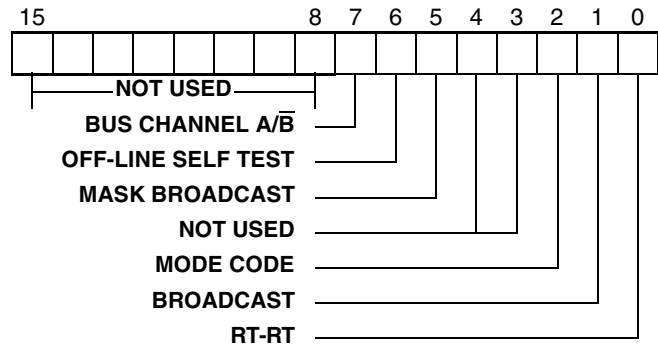

BIT NAME	DEFINITION
BUS CHANNEL A/B	Determines whether message will be transmitted on 1553 Bus A or Bus B. Logic 1 = A, logic 0 = B.
INITIATE OFF-LINE SELF TEST	Logic 1 performs internal off-line transmit/receive test. The last word of the message is looped back through the decoder and placed in RAM. See Self Test paragraph.
MASK BROADCAST (1)	When logic 1, prevents Broadcast RCVD bit of the 1553 Status Word response from signalling a status error as a result of a Broadcast command. (A FORMAT error will be generated if the BROADCAST bit is not set on the RTU's Status Word.)
MODE CODE	When logic 1, the message is treated as a Mode Code. (The Command Word - Word Count field indicates Mode Code type.)
BROADCAST	When logic 1, indicates that the message is a Broadcast Command. (No Status Word is expected.)
RT-RT	When logic 1, the message is treated as an RT-RT transfer. (The next two words are Command Words.) Both Status Word responses are validated.

Note:
 1. MASK BROADCAST XOR BROADCAST BIT in Status Word = STATUS SET ERROR.
 2. When the BC expects the BROADCAST bit set in the Status Word, a logic 1 will mask the Status Interrupt Error flag.

Figure 14 – BC CONTROL WORD

RESET

The CT2553 can be reset by pulsing the MSTRCLR (pin 71) low or by writing to the Start/Reset register. After a reset condition has occurred, the Configuration, Interrupt, and (internal) Block Status word register outputs are forced to a logic 0.

TIME TAGGING (OPTIONAL)

The CT2553 will automatically access an external, 3-state device (i.e., counter) at the start and end of each message in BC or RTU modes. The CT2553 output, $\overline{\text{TAGEN}}$ (pin 76), enables the device's output onto the common, 16-bit data highway while executing a memory-write cycle. The device's value is written into the second location of the Descriptor Stack Entry. If a counter is used its clock, enable, and reset control lines are connected per system requirement (See Figure 15). If no external device is attached to the data bus, an expected value of FFFF (H) will be written into the Time Tag location within the Descriptor Stack.

Note that the 8-bit Time Tag value generated in the 1553 MT mode of operation is implemented using an 8-bit counter internal to the CT2553 (See MT operation).

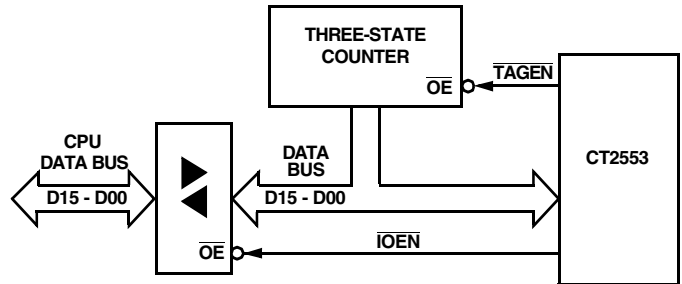

Figure 15 – BC/RT Tagging (Optional)

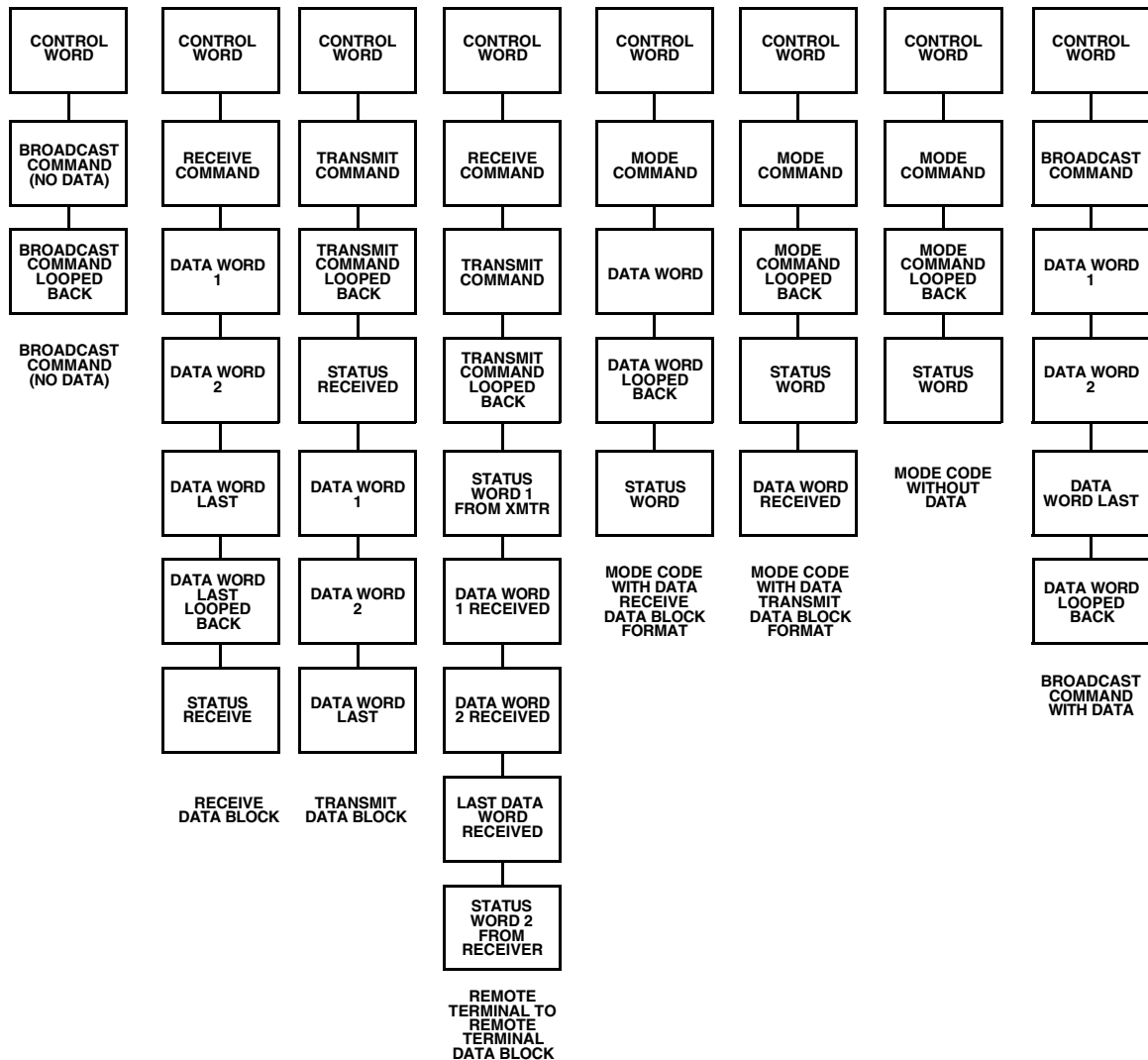

Figure 16 – BC Message Formats

BC OPERATION

Initialization of the CT2553 via a Reset or by setting the appropriate Configuration Register bits will result in placing the CT2553 in the BC operating mode.

BC MEMORY CONFIGURATION. The user configures the memory by: (1) writing the start address of the Descriptor Stack into the Current Area Stack Point location; (2) loading the fourth word of each Descriptor Stack Entry (DSE) with the start location of each message block; and (3) loading the Message Counter with the total number of messages to be transmitted. Note that the Message Count must be written in 1's compliment. For example, to transmit one message, load OOFE(H) (See Table 3, BC Memory Map).

If both map areas A and B are utilized, this procedure must be performed for each area. Note that the Stack Pointer and Message Counter locations are fixed; Message Block locations are user-defined.

Each message block must be preceded by a BC Control Word (See Figure 14). This word informs the CT2553 as to the format of the message transfer. Bit 1 of the Control Word defines whether the following message to RT 31 is to be issued in Broadcast Mode or whether RT 31 is a unique terminal. Memory locations must be reserved at the end of each message for: (1) a Loop Back Word; (2) RTU Status Word(s); and (3) received Data words. See Figure 16, BC Message Formats.

Message blocks may be loaded anywhere in the non-fixed area of the shared RAM. However, each data block may not cross a 256 word boundary (i.e., bit 8 of the starting address of the message block must match bit 8 of the address of the last word of the message block).

Table 3 - Typical BC Memory Map

HEX ADDRESS	FUNCTION
Fixed Areas	
0100	Stack Pointer A
0101	Message Count A
0104	Stack Pointer B
0105	Message Count B
User Defined Areas	
0108-013F	Not Used
0140-017F	Data Block 1
0180-01BF	Data Block 2
01C0-01FF	Data Block 3
•	•
•	•
0F00-0FFF	Descriptor Stack A
0000-00FF	Descriptor Stack B

ADDITIONAL FEATURES. The Configuration Register – STOP ON ERROR bit can be set. This causes the CT2553 to halt operation at the end of the current message transfer if an error is detected. In addition, setting the Interrupt Mask Register bits will result in a low pulse on the Interrupt (INT) pin with each occurrence of the respective error, end of message or end of message frame condition (See Configuration Register and Interrupt Register sections).

BC TRANSFER-START SEQUENCE

After setting the CONTROLLER START bit in the Start/Reset Register, the CT2553 takes the following actions:

1. Reads the Current Area Stack Pointer for the address of the Descriptor Stack Entry (DSE).
2. Stores an SOM (Start of Message) flag in the Block Status word to indicate a transfer operation in progress.
3. Writes the Time Tag value into the Descriptor Stack (See Time Tag).
4. Reads the Data Block Address from the fourth location of the DSE.
5. Starts the MIL-STD-1553 message transfer.

Upon completion of the MIL-STD-1553 message transfer, the CT2553:

1. Generates an End Of Message (EOM) or Error (if applicable) interrupt if enabled.
2. Reads the Stack Pointer for the address of the DSE.
3. Updates the Block Status Word; resets SOM, sets EOM, and sets any applicable Error bits.
4. Writes the Time Tag value into the Descriptor Stack (See Time Tag).
5. Increment Pointers: Stack Pointer incremented by 4 and Message Count incremented by 1.
6. If more messages remain to be sent, a BC End Of Message (BCEOM) interrupt occurs (if enabled).

If an error occurs and Stop On Error has been enabled, the CT2553 stops initiating BC Transfer-Start sequences. The Stack Pointer will point to the next message to be transferred (See Figure 17).

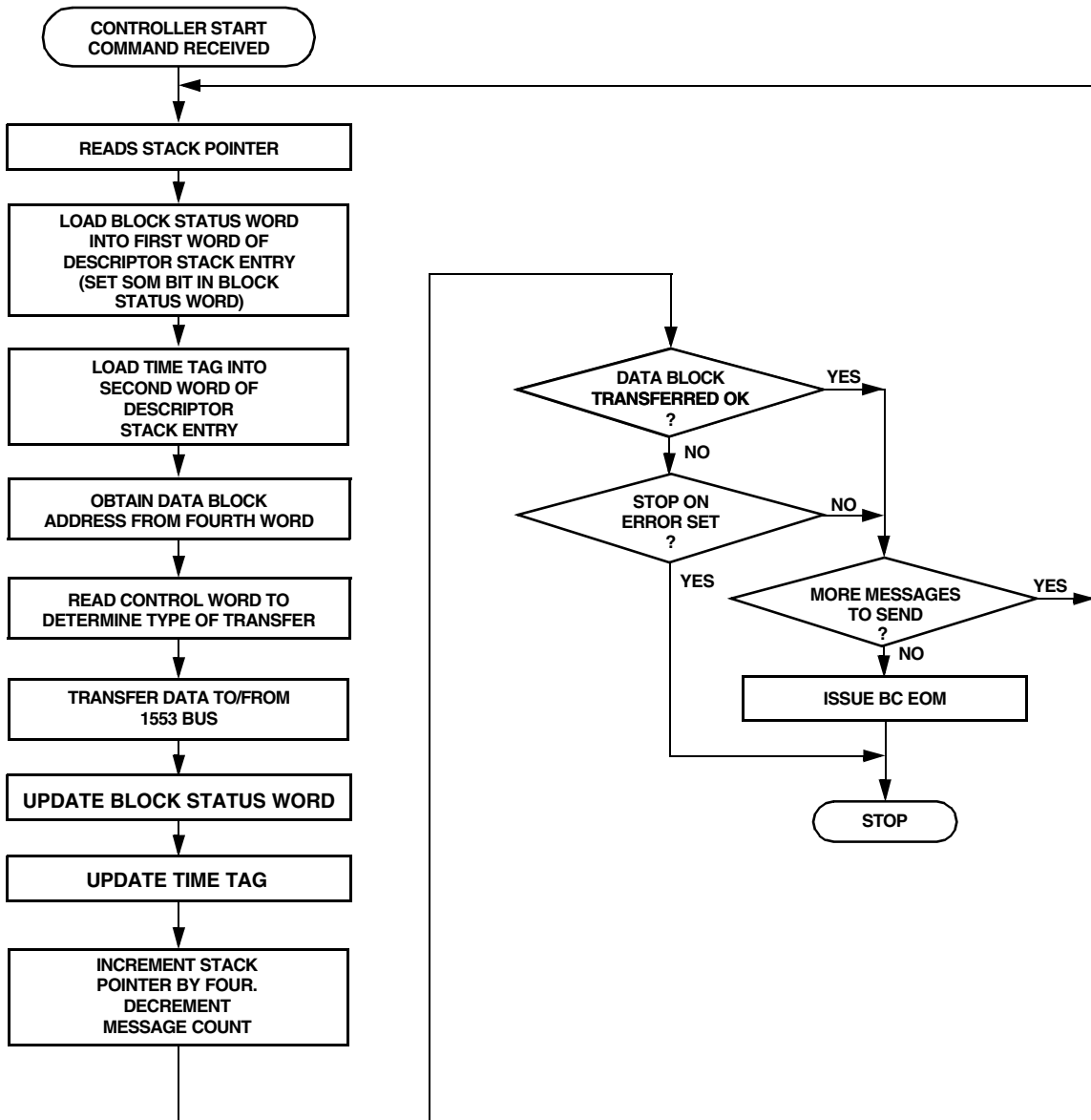

Figure 17 – BC Sequence of Operation

BC SETUP IMPLEMENTATION EXAMPLE

Figure 18a-c shows the BC mode examples for two message transfers, BASIC setup, and BC memory setup.

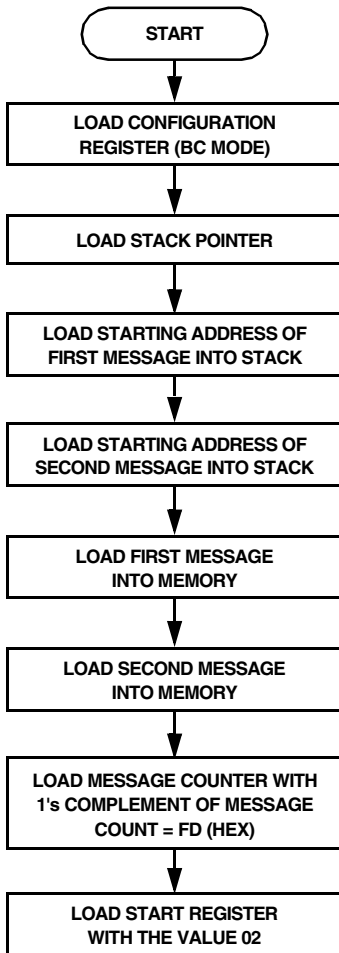

Figure 18a – BC Set-Up Example for Two Message Transfer

GIVEN:

1. All values are in hex.
2. Map Area "A" is used and located from Address 0000 to Address 00FF.
3. Message 1 located at Address 0140, is a TRANSMIT Command to RT# 1, Subaddress #1, Word Count = 1, transmitted on BUS A.
4. Message 2 located at Address 0180, is a RECEIVE Command to RT#3, Subaddress #1, Word Count = 3, transmitted on BUS B.
5. Configuration Register is assumed to be memory mapped at location 2001. START/RESET Register is memory mapped at location 2003.

```

MOV 2003, 0001 ; Issue Reset
MOV 2001, 0FFF ; Initialize Configuration Register
MOV 0100, 0000 ; Initialize Stack Pointer
MOV 0101, 00FD ; Initialize Message Count
MOV 0003, 0140 ; Load Start Address Of Message #1
MOV 0007, 0180 ; Load Start Address Of Message #2
MOV 0140, 0080 ; Load BC Control Word Message #1
MOV 0141, 0C21 ; Load Command Word Message #1
MOV 0180, 0000 ; Load BC Control Word Message #2
MOV 0181, 1823 ; Load Command Word Message #2
MOV 0182, 1111 ; Load Data Word #1 Message #2
MOV 0183, 2222 ; Load Data Word #2 Message #2
MOV 0184, 3333 ; Load Data Word #3 Message #2
MOV 2003, 0002 ; Issue "Start"
  
```

Figure 18b – Sample BC Set-Up Instructions

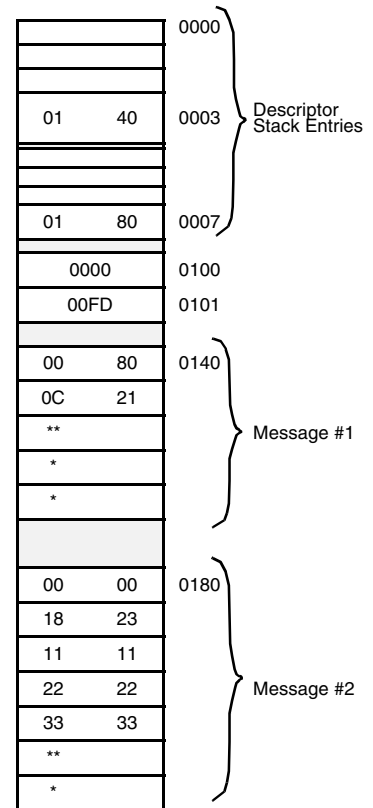

* Left empty for RTU's status response.
 ** Loop Back word.

Figure 18c – BC SET-UP Memory Map

RTU OPERATION

The RTU mode is selected by resetting the CT2553 and setting the appropriate bits in the Configuration Register.

RTU MEMORY CONFIGURATION. The user configures the memory by:

1. Writing the start address of the Descriptor Stack into the Stack Pointer location and
2. Setting up the Look-Up Table as described below.

If both map areas (A and B) are utilized, this procedure must be performed for each area. Note that the Stack Pointer and Look-Up Table locations are fixed; Data Block(s) locations are user-defined. Message blocks may be loaded anywhere in the non-fixed areas of the shared RAM. However, each data block may not cross a 256 word boundary (i.e., bit 8 of the starting address of the message block must match bit 8 of the address of the last word of the message block). An example of a typical RTU Memory Map is given in Table 4. Figure 19 shows the RTU Initialization steps.

Table 4 – Typical RTU Memory Map

HEX ADDRESS	FUNCTION
Fixed Areas	
0100	Descriptor Stack Pointer A
0101	Reserved
0104	Descriptor Stack Pointer B
0105	Reserved
0108-013F	Spare
0140-017F	Look-Up Table A
01C0-01FF	Look-Up Table B
User Defined Areas	
0180-019F	Data Block 1
01A0-01BF	Data Block 2
0200-021F	Data Block 3
•	•
•	•
0EE0-0EFF	Data Block 107
0000-00FF	Descriptor Stack A
0F00-0FFF	Descriptor Stack B

RTU LOOK-UP TABLE. The RTU mode uses a Look-Up Table in order to map the Data Blocks based upon incoming 1553 Command Words. The CT2553 uses the T/R and Subaddress fields to address the Look-Up Table. Each Look-Up Table (A and B) location contains a user-defined Data Block Pointer to an associated Data Block (See Figures 20 and 21).

Note: The Data Block and Stack Pointers are maintained internally using an 8-BIT-REGISTER for the HIGH BYTE and an 8-BIT COUNTER for the LOW BYTE; the high byte remains constant (user value) while the low byte will wrap around from FF(H) to 00(H). For example: a current Pointer value of 10 FF(H) will increment to 10 00(H) and not 11 00(H).

The first 32 words of the Look-Up Table are reserved for Data Blocks associated with Receive Commands (T/R bit = 0). The remaining 32 words are reserved for Data Blocks associated with Transmit Commands (T/R bit = 1).

Mode Commands with data are mapped in the same manner as non-mode commands. A Synchronize With Data command maps to the first or thirty-second Table entry (depending upon subaddress: all 0's or all 1's), while a Transmit Vector Word command points to the thirty-third or sixty-fourth entry.

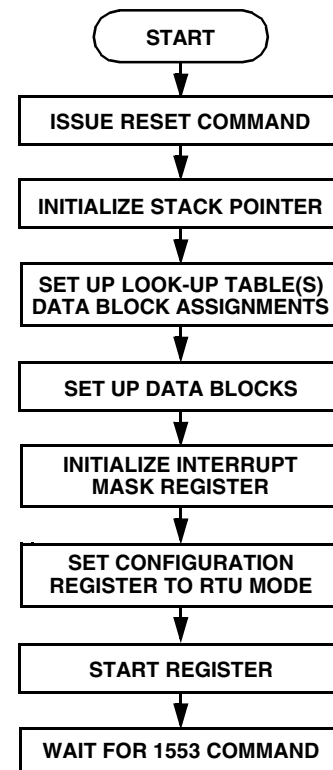

Figure 19 – RTU Initialization

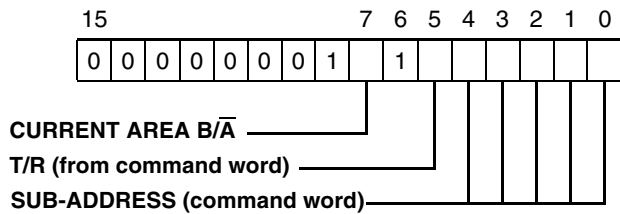

Figure 20 – RTU Look-Up Address

RTU MESSAGE BLOCK TRANSFER SEQUENCE

RTU message transfer operations begin automatically upon receipt of a valid command word from the 1553 bus. A message transfer takes the form of an RTU Start Of Message (SOM) cycle followed by the 1553 Message Transfer Cycle and an RTU End Of Message (EOM) cycle (See Figure 22).

During the RTU SOM cycle, the CT2553 the following actions:

1. Loads the 1553 command word.
2. Reads the current area Stack Pointer to get the address of the current Descriptor Stack Entry (DSE).
3. Stores an SOM flag into the Block Status Word to indicate a transfer in progress.
4. Writes the Time Tag value into the the Descriptor Stack.
5. Stores the Command Word received.
6. Reads the associated Data Block Address from the (current area) Look-Up Table.

The MESSAGE TRANSFER CYCLE refers to the actual transfer of the 1553 message under control of the CT2553. The CT2553 transfers data to and from the memory on a word-by-word basis.

Upon completion of the message transfer, the CT2553 executes an RTU End Of Message (EOM) cycle during which the CT2553:

1. Generates an EOM or Error interrupt (if enabled).
2. Updates the Block Status Word: clears SOM, sets EOM, and any appropriate error bits.
3. Writes the Time Tag value into the Descriptor Stack.
4. Increments the Stack Pointer by 4.

RECEIVED COMMAND WORDS				DATA BLOCK
T/R	SUBADD	WORD COUNT	LOOK-UP TABLE (A) ADDRESS	DATA BLOCK
0	00000	XXXXX	0140	USER DEFINED
0	00001	XXXXX	0141	USER DEFINED
0	00010	XXXXX	0142	USER DEFINED
		64 LOCATIONS	*	
			*	
1	11110	XXXXX	017E	USER DEFINED
1	11111	XXXXX	017F	USER DEFINED

Figure 21 – Look-Up Table Example

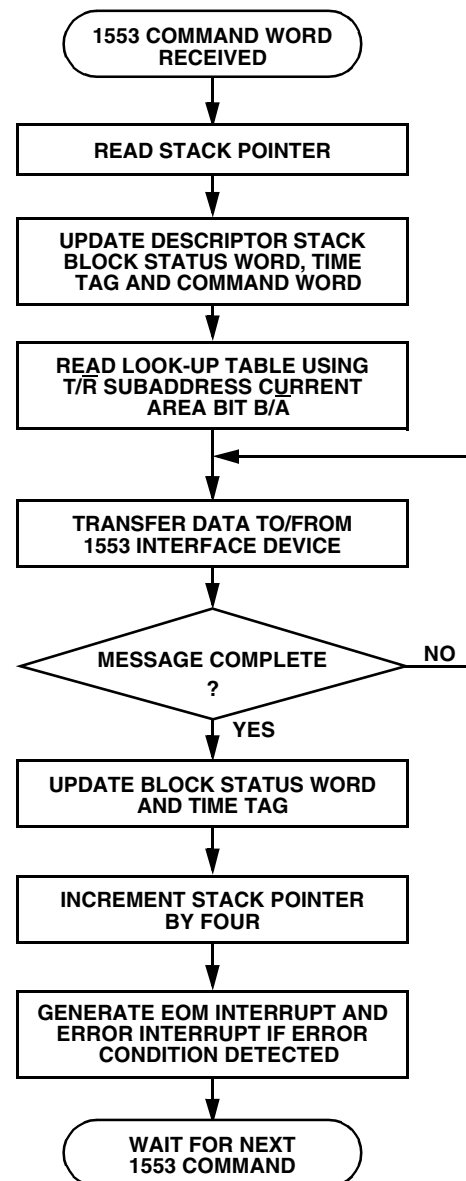

Figure 22 – RTU Message Transfer Operation

ADDITIONAL FEATURES. Four 1553 Status Word flags can be programmed via the appropriate Configuration Register bits. In addition, setting Interrupt Mask Register bits will result in a low pulse on the Interrupt ($\overline{\text{INT}}$) pin with each occurrence of the respective error or end of message condition. (See Configuration Register and Interrupt Register sections.)

THIS RT: Each command appearing on either 1553 Bus is decoded and tested for Manchester/protocol errors. If the CT2553 receives a valid command word containing a RTU address equivalent to the RTAD0-RTAD4 inputs (pins 10, 9, 50, 49, and 11, respectively), $\overline{\text{THIS-RT}}$ (pin 55) will be pulsed low. This signal can be used to identify specific 1553 commands. This signal is also active in the BC mode.

Command Illegalization (Optional). The CT2553 has the capability to illegalize MIL-STD-1553 mode commands. In addition, valid non-mode commands can be illegalized based upon the Command Word subaddress field. An illegal command is identified by driving the Illegal Command, $\overline{\text{ILLCMD}}$ (pin 12) input low. The CT2553 multiplexes the Word Count and Subaddress fields (pins SA/MC0 - SA/MC4).

The CT2553 responds to illegalized commands by transmitting its Status Word with the Message

Error bit set. No data words are transmitted; received words, however, are placed in the shared RAM locations indicated by the current area Look-Up Table.

Upon receipt of a valid mode command, the CT2553 will output the Command Word-Word Count field and set the Latched Mode Command (LMC) output to a logic 1. Upon receipt of a valid non-mode command, the CT2553 will output the Command Word-Subaddress field and set the Latched Mode Command (LMC) output to a logic 0.

An external PROM can be used for command illegalization by decoding the word count/subaddress, LMC and Broadcast Received ($\overline{\text{BCSTRCV}}$) bits and driving $\overline{\text{ILLCMD}}$ low where appropriate (See Figure 23).

BUSY BIT. If the user asserts the BUSY bit low in the Configuration Register, the CT2553 will respond with a Status Word with the BUSY bit set. In addition, no data words will be transferred from the shared RAM as indicated by the corresponding value in the current area Look-Up Table. The CT2553 will transfer data associated with a Receive Command into memory but will not transmit data out onto the MIL-STD-1553 bus when busy upon receipt of a Transmit Command.

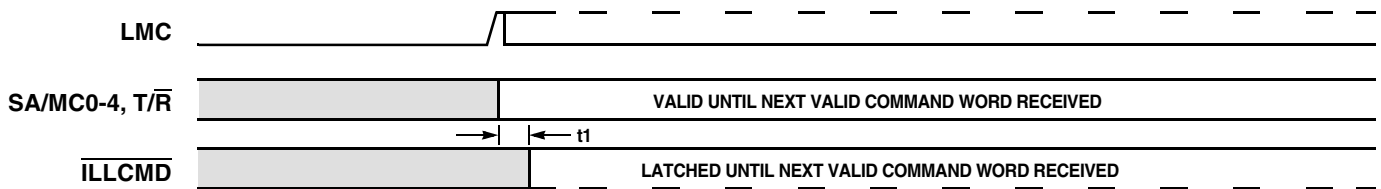

Mode Command Illegalization Timing

SYMBOL	DESCRIPTION	MIN	MAX	UNITS
t1	LMC to $\overline{\text{ILLCMD}}$ latch	250	-	ns

Figure 23 – Mode Command/Sub-Address Illegalization Timing

MT OPERATION

Initiate a Reset in order to initialize the CT2553. Configure the CT2553 as a Bus Monitor (MT) by setting the appropriate Configuration Register Bits. See Figure 24 for MT initialization Steps.

MT MEMORY CONFIGURATION. The user configures the memory by writing the start address for 1553 data storage into the Stack Pointer location. The Monitor Stack will automatically wrap around once the RAM has been filled (i.e., location FFF(H) is followed by location 0000). An example of a typical MT Memory Map 4 given in Table 5.

Table 5 – Typical MT Memory Map

HEX ADDRESS	FUNCTION
0000	First Received 1553 Word
0001	First Identification Word
0002	Second Received 1553 Word
0003	Second Identification Word
0004	•
0005	•
0006	•
•	•
•	•
0100	Stack Pointer (Fixed location)
•	•
•	•
FFFF	•

MT START SEQUENCE. After setting the CONTROLLER START bit in the Start/Reset Register, the CT2553 takes the following actions:

1. Reads the start address for 1553 data storage from the Stack Pointer location. The Stack Pointer location(s) will be overwritten with 1553 data once the MT mode has begun and 1553 data is written into locations 0100(H) and 0101(H)].
2. Stores the received 1553 word into memory.
3. Increments the Stack Pointer by 1.
4. Generates an Identification Word and stores this value into memory.
5. Repeats steps 2-4 until a Reset condition occurs.

MT IDENTIFICATION WORD. The Identification word provides the CPU with information pertaining to the received 1553 word. Its format is shown in Figure 25, This information allows the user to analyze the 1553 data.

THIS-RT: Each command appearing on either 1553 Bus is decoded and tested for Manchester/protocol errors. If the CT2553 receives a valid command word containing a Command Sync and a RTU address equivalent to the RTAD0-RTAD4 inputs (pins 10, 9, 50, 49, and 11, respectively), THIS-RT (pin 55) will be pulsed low. This signal can be used to identify specific 1553 commands or for switching to RTU mode upon receipt of a command to this address.

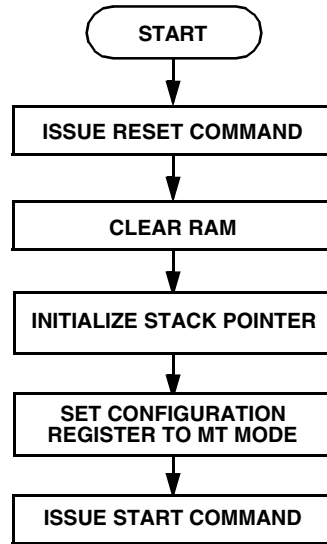
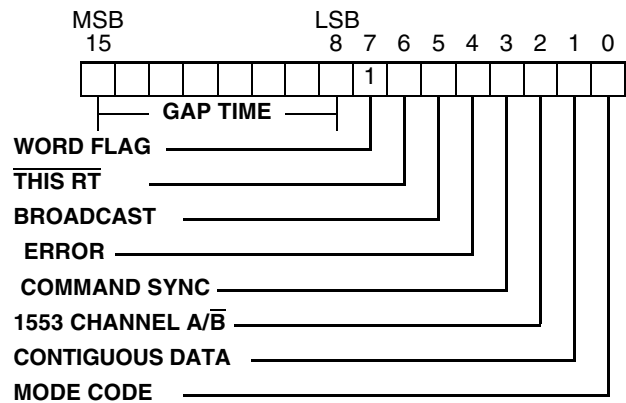

Figure 24 – MT Initialization



BIT NAME	DEFINITION
GAP TIME	Indicates the time between receipt of the previous and current words. Time is indicated in 0.5µs increments for a maximum of 128 µs and goes to FF over 128µs. (See Word Gap bit.)
WORD FLAG	Always logic 1.
THIS RT	Logic 0 indicates RT address field of the associated command or Status Word matches the RT address field of the CT2553.
BROADCAST	Logic 0 indicates the RTU address field of the command or Status Word corresponds to address 31 (decimal).
ERROR	Logic 1 indicates Manchester, Parity, Sync and/or low bit counter.
COMMAND SYNC	Logic 1 indicates 1553 Command or Status Word sync field. (Logic 0 indicates a Data Word sync field in received word.)
1553 CHANNEL A/B	Indicates word received on 1553 Bus A (1) or Bus B (0).
CONTIGUOUS DATA	Logic 1 indicates the word was received within 2µs of the previous word. If logic 0, bits 8-15 contain the measured gap between the words.
MODE CODE	When logic 1, the data transferred is a mode code command.

Figure 25 – MT Identification Word

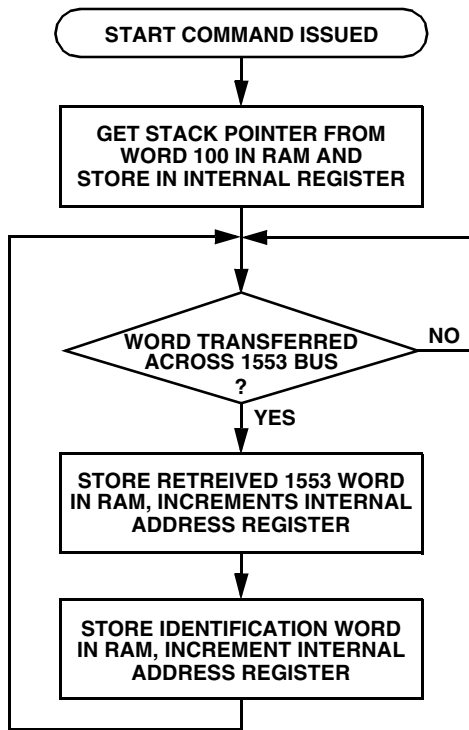

Figure 26 – MT Data Storage Operation

MT DATA STORAGE. Figure 26 shows the steps in a MT data Storage operation.

INTERRUPTS: SA/MC - 0 (pin 13), SA/MC - 1 (pin 52) and SA/MC - 2 (on 52) represents B6, B7, and B8 counter outputs in the MT mode. B6 counts every 32 words transferred, B7 every 64 words, and B8 every 128 words. These counter outputs can be used to generate interrupts to the subsystem to insure proper servicing of Memory. The Data Word and Identification Word transfers increment the counter by two.

BUILT-IN-TEST WORD (RTU MODE)

The CT2553 contains a 14 bit Built-In-Test (BIT) word register which stores information about the condition of the RTU. When a Mode Command is received to transmit BIT word, the contents of this register are transmitted over the 1553 data bus. Figure 27 shows the meaning of each bit in the BIT register. Information is included regarding transmitter timeouts, loop test failures, transmitter shutdown, subsystem handshake failure, and the results of individual message validations.

MODE CODES

The CT2553 implements all mode codes applicable to dual redundant systems. Mode codes can also be illegalized using the appropriate I/O signals. Mode command illegalization and handling are detailed in the RTU Operation section and listed in Table 6.

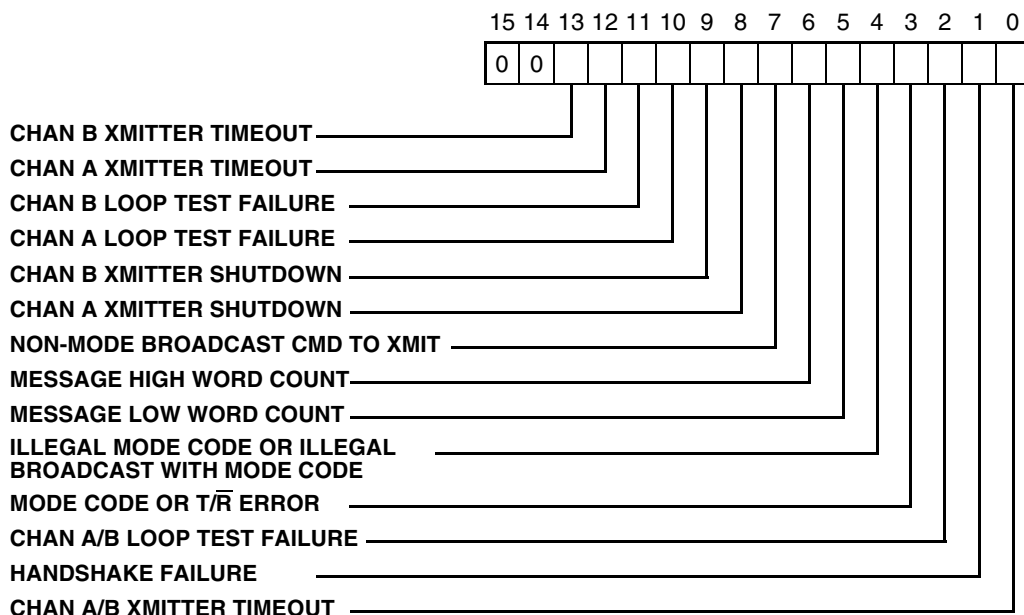

- Notes:
- (1) Bits 0-2 and 10-13 are latched and only cleared by a mode reset command or a master $\overline{\text{RESET}}$.
 - (2) Bits 3-7 are cleared at the start of each new message and updated at the end of the message. They reflect the present command word.
 - (3) Bits 8-9 are set by the mode command for Transmitter Shutdown and are cleared by the mode command for Override Transmitter Shutdown, Reset RT or a master $\overline{\text{RESET}}$.

Figure 27 – Built-In-Test Word (RTU Mode)

DYNAMIC BUS CONTROL (00000)

MESSAGE SEQUENCE = DBC * STATUS

The CT2553 responds with status. If the subsystem wants control of the bus, it must set DBACC within 2.5us after NBGRT.

ERROR CONDITIONS

1. **Invalid Command.** No response, command ignored.
2. **Command Followed by Data Word.** No status response. Bits set: message error (SW), High word Count (BIT Word).
3. **T/R bit Set to Zero.** No status response. Bits set: message error (SW), T/R Error (Bit Word).
4. **Zero T/R bit and Broadcast Address.** No status response. Bits set: message error, broadcast received (SW), Illegal Mode Code, T/R Error (BIT Word).
5. **Broadcast Address.** No status response. Bits set: message error, broadcast received (SW), Illegal Mode Code (BIT Word).

SYNCHRONIZE WITHOUT DATA WORD (00001)

MESSAGE SEQUENCE = SYNC * STATUS

The CT2553 responds with status. If sent as a broadcast, the broadcast receive bit will be set and status response suppressed.

ERROR CONDITIONS

1. **Invalid Command.** No response, command ignored.
2. **Command Followed by Data Word.** No status response. Bits set: message error (SW), High Word Count (BIT Word).
3. **T/R bit Set to Zero.** No status response. Bits set: message error (SW), T/R Error (BIT Word).
4. **Zero T/R bit and Broadcast Address.** No status response. Bits set: message error, broadcast received (SW), Illegal Mode Code, T/R Error (BIT Word).

TRANSMIT STATUS WORD (00010)

MESSAGE SEQUENCE = TRANSMIT STATUS * STATUS

The status and BIT word registers are not altered by this command and contain the resulting status from the previous command.

ERROR CONDITIONS

1. **Invalid Command.** No response, command ignored.
2. **Command Followed by Data Word.** No status response. Bits set: message error (SW), High Word Count (BIT Word).
3. **T/R bit Set to Zero.** No status response. Bits set: message error (SW), T/R Error (BIT Word).
4. **Zero T/R bit and Broadcast Address.** No status response. Bits set: message error, broadcast received (SW), Illegal Mode Code, T/R Error (BIT Word).
5. **Broadcast Address.** No status response. Bits set: message error, broadcast received (S/W), Illegal Mode code, T/R Error (BIT Word).

INITIATE SELF-TEST (00011)

MESSAGE SEQUENCE = SELF TEST * STATUS

The CT2553 responds with a status word. If the command was broadcast, the broadcast received bit is set and status transmission suppressed. Short-loop test is initiated on the status word transmitted. If the test fails, an RT fail flag is generated.

ERROR CONDITIONS

1. **Invalid Command.** No response, command ignored.
2. **Command Followed by Data Word.** No status response. Bits set: message error (SW), High Word Count (BIT Word).
3. **T/R bit Set to Zero.** No status response. Bits set: message error (SW), T/R Error (BIT Word).
4. **Zero T/R bit and Broadcast Address.** No status response. Bits set: message error, broadcast received (SW), T/R Error (BIT Word).
5. **Faulty Test.** Bits set: terminal flag (SW), A/B Loop Test Fail, Current 1553 Bus (A or B) Loop Test Fail (BIT Word).

TRANSMITTER SHUTDOWN (00100)

MESSAGE SEQUENCE - SHUTDOWN * STATUS

This command is only used with dual redundant bus systems. The CT2553 responds with status. At the end of the status transmission, the CT2553 inhibits any further transmission from the dual redundant channel. Once shutdown, the transmitter can only be re-activated by Override Transmitter Shutdown or RESET RT commands.

ERROR CONDITIONS

1. **Invalid Command.** No response, command ignored.
2. **Command Followed by Data Word.** No status response. Bits set: message error (SW), High Word Count (BIT Word).
3. **T/R bit Set to Zero.** No status response. Bits set: message error (SW), T/R Error BIT Word).
4. **Zero T/R bit and Broadcast Address.** No status response. Bits set: message error, broadcast received (SW), Illegal Mode Code, T/R Error (BIT Word).

Table 6 – Mode Codes

OVERRIDE TRANSMITTER SHUTDOWN (00101)

MESSAGE SEQUENCE - OVERRIDE SHUTDOWN - STATUS

This command is only used with dual redundant bus systems. The CT2553 responds with status. At the end of the status transmission, the CT2553 re-enables the transmitter of the redundant bus. If the command was broadcast, the broadcast received bit is set and status transmission is suppressed.

ERROR CONDITIONS

1. **Invalid Command.** No response, command ignored.
2. **Command Followed by Data Word.** No status response. Bits set: message error (SW), High Word Count (BIT Word).
3. **T/R bit Set to Zero.** No status response. Bits set: message error (SW), T/R Error (BIT Word).
4. **Zero T/R bit and Broadcast Address.** No status response. Bits set: message error, broadcast received (SW), Illegal Mode Code, T/R Error (BIT Word).

INHIBIT TERMINAL FLAG BIT (00110)

MESSAGE SEQUENCE - INHIBIT TERMINAL FLAG * STATUS

The CT2553 responds with status and inhibits further internal or external setting of the terminal flag bit in the status register. Once the terminal flag has been inhibited, it can only be reactivated by an Override Inhibit Terminal Flag or Reset RT command. If the command was broadcast, the broadcast received bit is set and status transmission is suppressed.

ERROR CONDITIONS

1. **Invalid Command.** No response, command ignored.
2. **Command Followed by Data Word.** No status response. Bits set: message error (SW), High Word Count (BIT Word).
3. **T/R bit Set to Zero.** No status response. Bits set: message error (SW), T/R Error (BIT Word).
4. **Zero T/R bit and Broadcast Address.** No status response. Bits set: message error, broadcast received (SW), T/R Error (BIT Word).

OVERRIDE INHIBIT TERMINAL FLAG BIT (00111)

MESSAGE SEQUENCE - OVERRIDE INHIBIT TERMINAL FLAG * STATUS

The RTU responds with status and reactivates the terminal flag bit in the status register. If the command was broadcast, the broadcast received bit is set and status transmission is suppressed.

ERROR CONDITIONS

1. **Invalid Command.** No response, command ignored.
2. **Command Followed by Data Word.** No status response. Bits set: message error (SW), High Word Count (BIT Word).
3. **T/R bit Set to Zero.** No status response. Bits set: message error (SW), T/R Error (BIT Word).
4. **Zero T/R bit and Broadcast Address.** No status response. Bits set: message error, broadcast received (SW), T/R Error (BIT Word).

RESET REMOTE TERMINAL (01000)

MESSAGE SEQUENCE - RESET REMOTE TERMINAL * STATUS

The CT2553 responds with status and internally resets. Transmitter shutdown, mode commands, and inhibit terminal flag commands will be reset. If the command was broadcast, the broadcast received bit is set and the status word is suppressed.

ERROR CONDITIONS

1. **Invalid Command.** No response, command ignored.
2. **Command Followed by Data Word.** No status response. Bits set: message error (SW), High Word Count (BIT Word).
3. **T/R bit Set to Zero.** No status response. Bits set: message error (SW), T/R Error (BIT Word).
4. **Zero T/R bit and Broadcast Address.** No status response. Bits set: message error, broadcast received (SW), T/R Error (BIT Word).

RESERVED MODE CODES (01001-01111)

MESSAGE SEQUENCE = RESERVED MODE CODES * STATUS

The CT2553 responds with status. If the command is illegalized through an optional PROM, the message error bit is set and only the status word is transmitted.

ERROR CONDITIONS

1. **Invalid Command.** No response, command ignored.
2. **Command Followed by Data Word.** No status response. Bits set: message error (SW), High Word Count (BIT Word).
3. **T/R bit Set to Zero.** No status response. Bits set: message error (SW), Illegal Mode Code (BIT Word).
4. **Zero T/R bit and Broadcast Address.** No status response. Bits set: message error, broadcast received (SW), Illegal Mode Code (BIT Word).

Table 6 – Mode Codes (continued)

TRANSMIT VECTOR WORD (10000)

MESSAGE SEQUENCE - TRANSMIT VECTOR WORD * STATUS VECTOR WORD

The CT2553 transmits a status word followed by a vector word. The contents of the vector word (from the subsystem) are enabled onto DBO-DB15 with BUSREQ after the command transfer (same as data word in a normal transmit command).

ERROR CONDITIONS

1. **Invalid Command.** No response, command ignored.
2. **Command Followed by Data Word.** No status response. Bits set: message error (SW) High Word Count (BIT Word).
3. **T/R bit Set to Zero.** No status response. Bits set: message error (SW), T/R Error, Low Word Count (BIT Word).
4. **Zero T/R bit and Broadcast Address.** No status response. Bits set: message error, broadcast received (SW), Illegal Mode Code, T/R Error, Low Word Count (BIT Word).
5. **Broadcast Address.** No status response. Bits set: message error, broadcast received (SW), Illegal Mode code, (BIT Word).

SYNCHRONIZE WITH DATA WORD (10001)

MESSAGE SEQUENCE - SYNCHRONIZE DATA WORD * STATUS

The data word received following the command word is transferred to the subsystem. The status register is then enabled and its contents transferred onto the data bus and transmitted. If the command was broadcast, the broadcast received bit is set and status transmission is suppressed.

ERROR CONDITIONS

1. **Invalid Command.** No response, command ignored.
2. **Command Not Followed by Data Word.** No status response. Bits set: message error (SW), Low Word Count (BIT Word).
3. **Command followed by too many Data Words.** No status response. Bits set: message error (SW), High Word Count (BIT word).
4. **Command T/R bit Set to One.** No status response. Bits set: message error (SW), T/R Error, High Word Count (BIT Word).
5. **Command, T/R bit Set to One and Broadcast Address.** No status response. Bits set: message error, broadcast received (SW), High Word Count, T/R Error (BIT Word).

TRANSMIT LAST COMMAND (10010)

MESSAGE SEQUENCE = TRANSMIT LAST COMMAND * STATUS LAST COMMAND

The status and BIT word registers are not altered by this command. The SW contains the status from the previous command. The data word transmitted contains the previous valid command (providing it was not another TRANSMIT LAST COMMAND).

ERROR CONDITIONS

1. **Invalid Command.** No response, command ignored.
2. **Command Followed by Data Word.** No status response. Bits set: message error (SW).
3. **T/R bit Set to Zero.** No status response. Bits set: message error (SW), T/R Error, Low Word Count (BIT Word).
4. **Zero T/R bit and Broadcast Address.** No status response. Bits set: message error, (SW), Illegal Mode Code T/R Error (BIT Word).
5. **Broadcast Address.** No status response. Bits set: message error, broadcast received (SW), Illegal Mode Code (BIT Word).

TRANSMIT BIT WORD (10011)

MESSAGE SEQUENCE - TRANSMIT BIT WORD * STATUS BIT WORD

The CT2553 transmits a status word followed by the BIT word. When activated, BITEN allows the subsystem to latch the BIT word on the parallel data bus. The BIT word is not altered by this command; however, the next SW will reflect errors in this transmission.

ERROR CONDITIONS

1. **Invalid Command.** No response, command ignored.
2. **Command Followed by Data Word.** No status response. Bits set: message error (SW).
3. **T/R bit Set to Zero.** No status response. Bits set: message error (SW), T/R Error, Low Word Count (BIT Word).
4. **Zero T/R bit and Broadcast Address.** No status response. Bits set: message error, broadcast received (SW), Illegal Mode Code, T/R Error, Low Word Count (BIT Word).
5. **Broadcast Address.** No status response. Bits set: message error, broadcast received (SW), Illegal Mode code, (BIT Word).

Table 6 – Mode Codes (continued)

SELECTED TRANSMITTER SHUTDOWN (10100)

MESSAGE SEQUENCE - TRANSMITTER SHUTDOWN DATA * STATUS

The data word received is transferred to the subsystem and status is transmitted. If the command was broadcast, the broadcast received bit is set and status transmission suppressed. Intended for use with RTs with more than one dual redundant channel.

ERROR CONDITIONS

1. **Invalid Command.** No response, command ignored.
2. **Command Not Followed by Data Word.** No status response. Bits set: message error (SW), High Word Count, Illegal Mode Code (BIT Word).
3. **Command Followed by too many Data Words.** No status response. Bits set: message error (SW), Low Word Count, Illegal Mode Code (BIT Word).
4. **Command T/R bit Set to One.** No status response. Bits set: message error (SW), Illegal Mode Code, High word count (BIT Word).
5. **Command T/R bit Set to One and Broadcast Address.** No status response. Bits set: message error, broadcast received (SW), Illegal Mode Code, High Word Count (BIT Word).

OVERRIDE SELECTED TRANSMITTER SHUTDOWN (10101)

MESSAGE SEQUENCE - TRANSMITTER SHUTDOWN DATA * STATUS

The data word received after the command word is transferred to the subsystem. If the command was broadcast, the broadcast received bit is set and status transmission suppressed.

ERROR CONDITIONS

1. **Invalid Command.** No response, command ignored.
2. **Command Not Followed by Data Word.** No status response. Bits set: message error (SW), Low Word Count, Illegal Mode Code (BIT Word).
3. **Command Followed by too many Data Words.** No status response. Bits set: message error (SW), High Word Count, Illegal Mode Code (BIT Word).
4. **Command T/R bit Set to One.** No status response. Bits set: message error (SW), Illegal Mode Code, High Word Count (Bit Word).
5. **Command T/R bit Set to One and Broadcast Address.** No status response. Bits set: message error, broadcast received (SW), Illegal Mode Code, High Word Count, T/R (BIT Word).

RESERVED MODE CODES

MESSAGE SEQUENCE = RESERVED MODE CODE (T/R = 1) * STATUS

RESERVED MODE CODE (T/R = 0) * STATUS

The CT2553 responds with status. If the command was broadcast, the broadcast received bit is set and status transmission suppressed.

ERROR CONDITIONS (T/R = 1)

1. **Invalid Command.** No response, command ignored.
2. **Command Followed by Data Word.** No status response. Bits set: message error (SW), High Word Count, Illegal Mode Code (BIT Word).

ERROR CONDITIONS (T/R = 0)

1. **Invalid Command.** No response, command ignored.
2. **Command not Followed by Contiguous Data Word.** No status response. Bits set: message error (SW), High word Count, Illegal Mode Code (BIT Word).
3. **Command Followed by too many Data Words.** No status response. Bits set: message error (SW), High Word Count, Illegal Mode Code (BIT Word).

Table 6 – Mode Codes (continued)

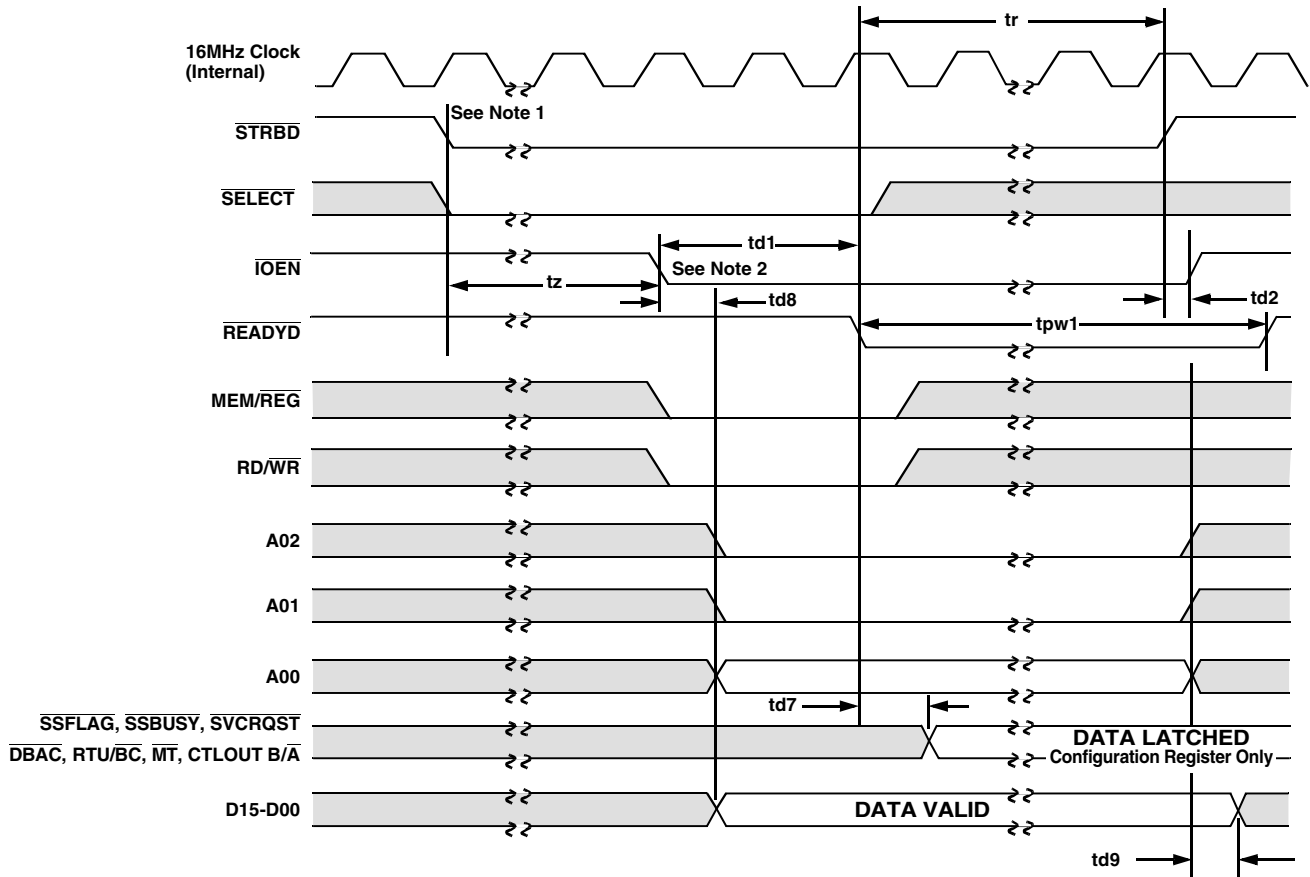

NOTE:
 1. STRBD to IOEN (low) delay is two clock cycles. If contention occurs, delay is two clock cycles following release of bus.
 2. CPU must release STRBD within 1.5µs of IOEN going active. READYD will go away within one clock cycle maximum.

CPU Writes to Internal Register

SYMBOL	DESCRIPTION	MIN	MAX	UNITS
td1	$\overline{\text{READYD}}$ low delay (CPU Handshake)	-	150	ns
td2	$\overline{\text{IOEN}}$ high delay (CPU Handshake)	-	20	ns
tpw1	$\overline{\text{READYD}}$ pulse width (CPU Handshake)	50	-	ns
td7	Internal Register delay (write)	-	60	ns
td8	Register Data/Address set-up time	-	30	ns
td9	Register Data/Address hold time	-	0	ns
tr	$\overline{\text{READYD}}$ to $\overline{\text{STRBD}}$ release	-	1.37	µs
tz	$(\overline{\text{SELECT}} \cdot \overline{\text{STRBD}})$ to $\overline{\text{IOEN}}$	-	1.8	µs

Figure 28 – CPU Writes to Internal Register

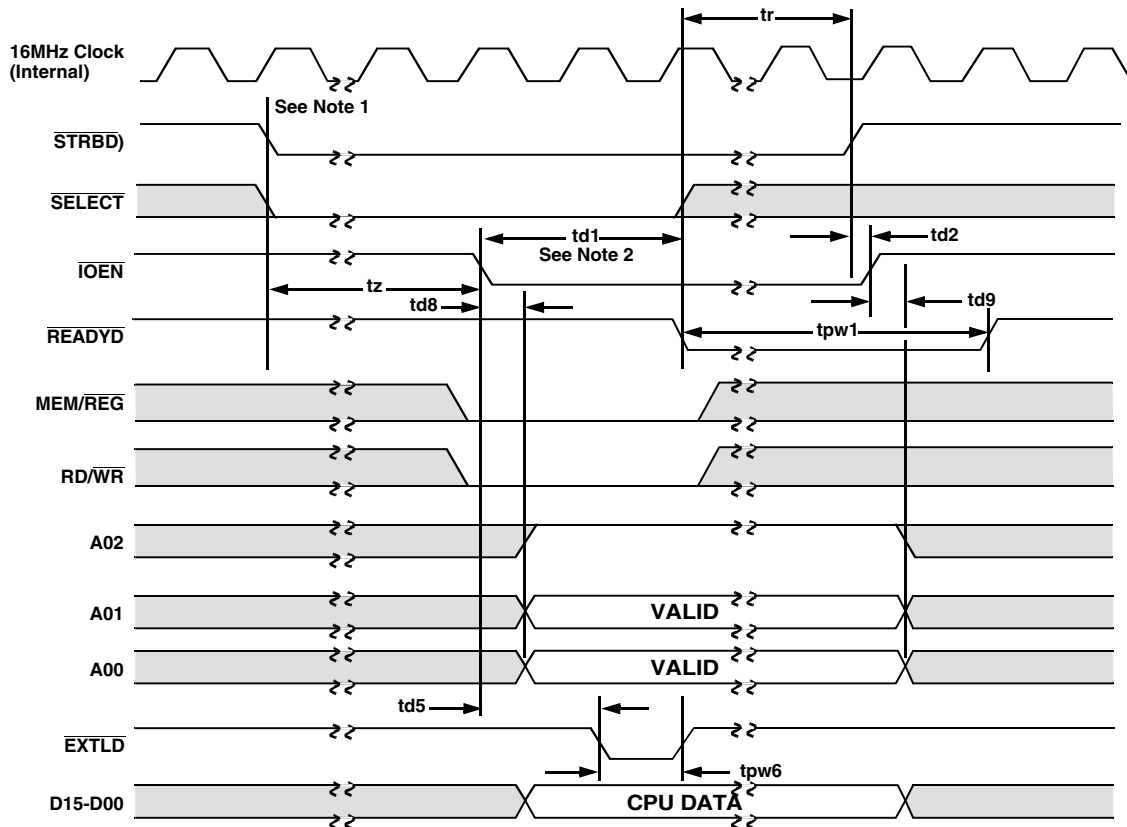

NOTE:

1. STRBD to IOEN (low) delay is two clock cycles. If contention occurs, delay is two clock cycles following release of bus.
2. CPU must release STRBD within 1.5µs of IOEN going active. READYD will go away within one clock cycle maximum.

CPU Writes to External Register

SYMBOL	DESCRIPTION	MIN	MAX	UNITS
td1	READYD low delay (CPU Handshake)	-	150	ns
td2	IOEN high delay (CPU Handshake)	-	20	ns
tpw1	READYD pulse width (CPU Handshake)	50	-	ns
td5	EXTLD low delay	50	-	ns
td8	Register Data/Address set-up time	-	30	ns
td9	Register Data/Address set-up time	-	0	ns
tpw6	EXTLD low pulse width	56	-	ns
tr	READYD to STRBD release	-	1.37	µs
tz	(SELECT • STRBD) to IOEN	-	1.8	µs

Figure 29 – CPU Writes to External Register

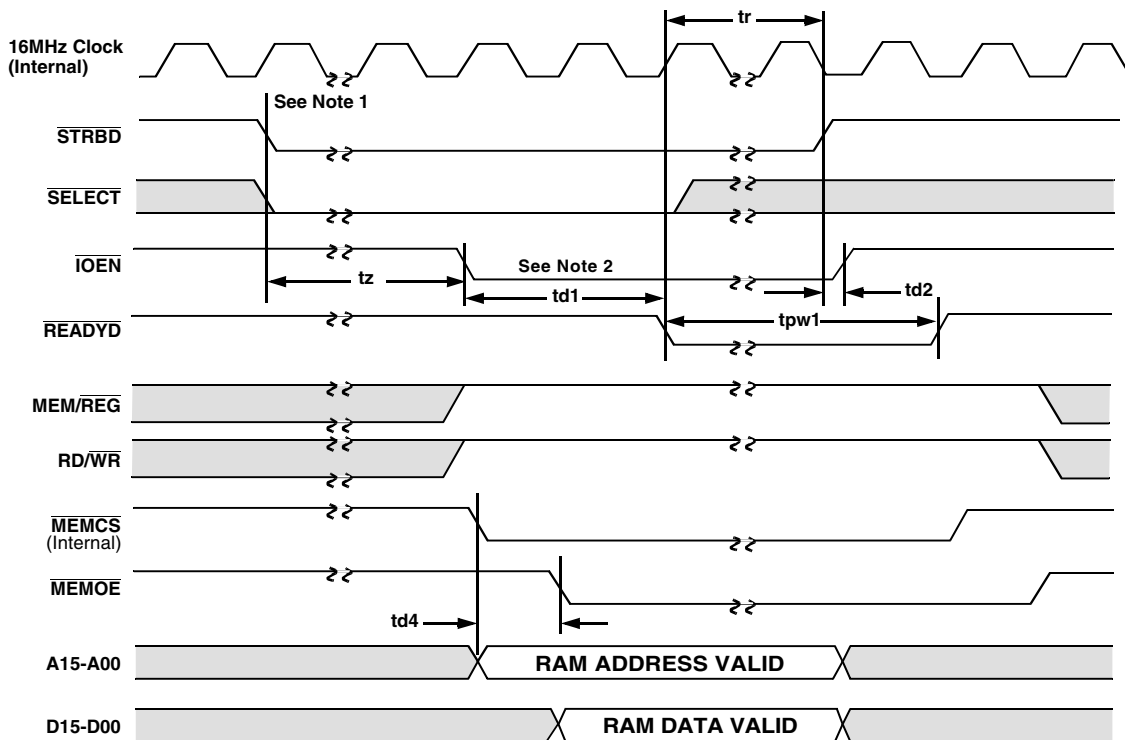

NOTE:

1. $\overline{\text{STRBD}}$ to $\overline{\text{IOEN}}$ (low) delay is two clock cycles. If contention occurs, delay is two clock cycles following release of bus.
2. CPU must release $\overline{\text{STRBD}}$ within 1.5 μs of $\overline{\text{IOEN}}$ going active. $\overline{\text{READYD}}$ will go away within one clock cycle maximum.

CPU Reads from RAM

SYMBOL	DESCRIPTION	MIN	MAX	UNITS
td1	$\overline{\text{READYD}}$ low delay (CPU Handshake)	-	150	ns
td2	$\overline{\text{IOEN}}$ high delay (CPU Handshake)	-	20	ns
tpw1	$\overline{\text{READYD}}$ pulse width (CPU Handshake)	50	-	ns
td4	CPU $\overline{\text{MEMOE}}$ low delay	-	100	ns
tr	$\overline{\text{READYD}}$ to $\overline{\text{STRBD}}$ release	-	1.37	μs
tz	$(\overline{\text{SELECT}} \cdot \overline{\text{STRBD}})$ to $\overline{\text{IOEN}}$	-	1.8	μs

Figure 30 – CPU Reads from RAM Timing

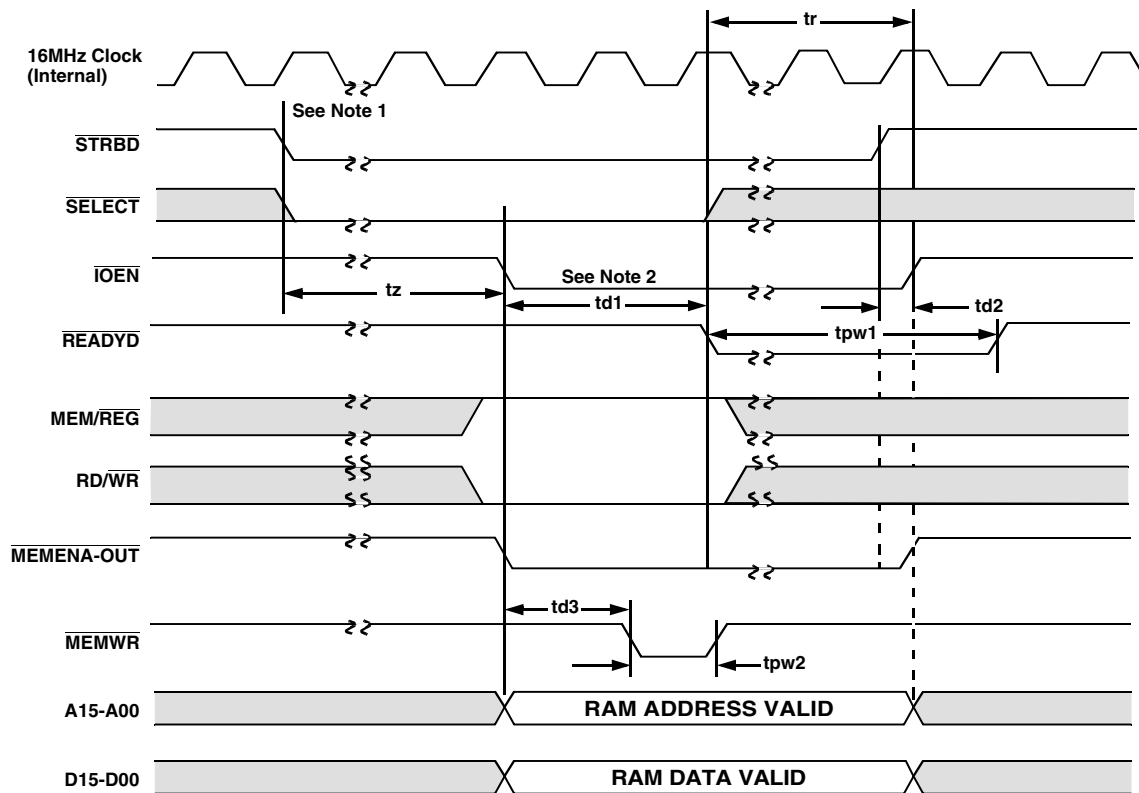

NOTE:

1. STRBD to IOEN (low) delay is two clock cycles. If contention occurs, delay is two clock cycles following release of bus.
2. CPU must release STRBD within 1.5µs of IOEN going active. READYD will go away within one clock cycle maximum.

CPU Writes to Ram

SYMBOL	DESCRIPTION	MIN	MAX	UNITS
td1	READYD low delay (CPU Handshake)	-	150	ns
td2	IOEN high delay (CPU Handshake)	-	20	ns
tpw1	READYD pulse width (CPU Handshake)	50	-	ns
td3	CPU MEMWR low delay	-	120	ns
tpw2	CPU MEMWR low pulse width	70	-	ns
tr	READYD to STRBD release	-	1.37	µs
tz	(SELECT • STRBD) to IOEN	-	1.8	µs

Figure 31 – CPU Writes to RAM Timing

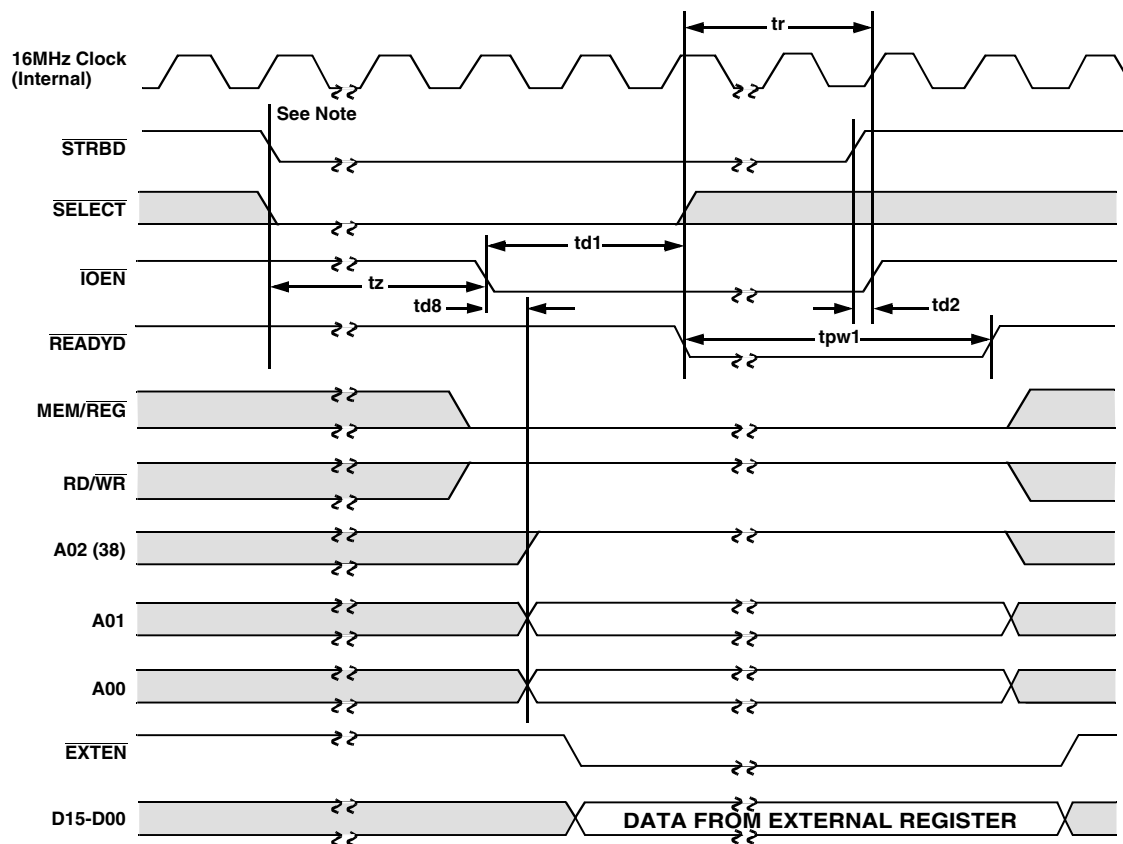

NOTE: $\overline{\text{STRBD}}$ to $\overline{\text{IOEN}}$ (low) delay is two clock cycles. If contention occurs, delay is two clock cycles following release of bus.

CPU Reads from External Register Timing

SYMBOL	DESCRIPTION	MIN	MAX	UNITS
td1	$\overline{\text{READYD}}$ low delay (CPU Handshake)	-	150	ns
td2	$\overline{\text{IOEN}}$ high delay (CPU Handshake)	-	20	ns
tpw1	$\overline{\text{READYD}}$ pulse width (CPU Handshake)	50	-	ns
td8	Register Data/Address set-up time	-	40	ns
tr	$\overline{\text{READYD}}$ to $\overline{\text{STRBD}}$ release	-	1.37	μs
tz	$(\overline{\text{SELECT}} \cdot \overline{\text{STRBD}})$ to $\overline{\text{IOEN}}$	-	1.8	μs

Figure 32 – CPU Reads from External Register Timing

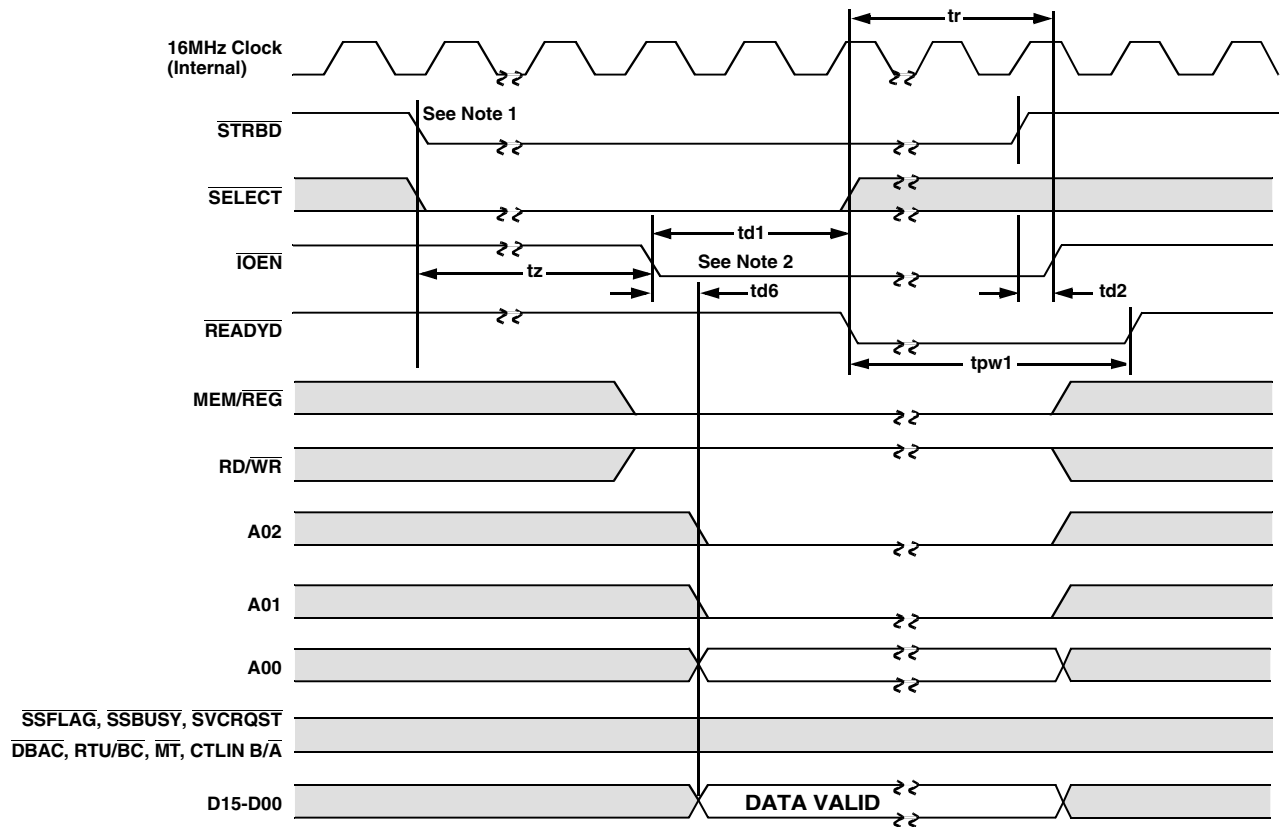

NOTE:
 1. STRBD to IOEN (low) delay is two clock cycles. If contention occurs, delay is two clock cycles following release of bus.
 2. CPU must release STRBD within 1.5µs of IOEN going active. READYD will go away within one clock cycle maximum.

CPU Reads from Internal Register

SYMBOL	DESCRIPTION	MIN	MAX	UNITS
td1	READYD low delay (CPU Handshake)	-	200	ns
td2	IOEN high delay (CPU Handshake)	-	20	ns
tpw1	READYD pulse width (CPU Handshake)	70	-	ns
td6	Internal Register delay (read)	-	60	ns
tr	READYD to STRBD release	-	1.37	µs
tz	(SELECT • STRBD) to IOEN	-	1.8	µs

Figure 33 – CPU Reads from Internal Register Timing

Table 7A – CT2553 Pin Function Table (78 Pin DIP)

Pin	Name	I _{IH} (μ A)	I _{IL} (mA)	I _{OH} (μ A)	I _{OL} (mA)	Description
1	D00	(5)	-0.4	-400	3.6	I/O Data Bus Bit 0 (LSB).
2	D02	(5)	-0.4	-400	3.6	I/O Data Bus Bit 2.
3	D04	(5)	-0.4	-400	3.6	I/O Data Bus Bit 4.
4	D06	(5)	-0.4	-400	3.6	I/O Data Bus Bit 6.
5	D08	(5)	-0.4	-400	3.6	I/O Data Bus Bit 8.
6	D10	(5)	-0.4	-400	3.6	I/O Data Bus Bit 10.
7	D12	(5)	-0.4	-400	3.6	I/O Data Bus Bit 12.
8	D14	(5)	-0.4	-400	3.6	I/O Data Bus Bit 14.
9	RTAD1	(5)	-0.4	-	-	Remote Terminal Address Bit 1.
10	RTAD0	(5)	-0.4	-	-	Remote Terminal Address Bit 0 (LSB)
11	RTAD4	(5)	-0.4	-	-	Remote Terminal Address Bit 4 (MSB)
12	$\overline{\text{ILLCMD}}$	+10	± 0.01	-	-	Legal Command. Defines the received command as illegal.
13	SA/MC-0	-	-	-400	2.0	Subaddress/Mode Command Bit 0. Multiplexed output bit-0 of subaddress/word count field of the current command word. SA/MC determined by the state of LMC.
14	Logic +5V	-	-	-	-	+5V supply input for digital logic section. B6 counter.
15	SA/MC-1	-	-	-400	2.0	Subaddress/Mode Command Bit 1. In MT mode, pulses every time 32 words have been stored. B7 counter.
16	$\overline{\text{BCSTRCV}}$	-	-	-400	2.0	Broadcast Received. Indicates current command is a 1553 Broadcast Command.
17	LMC	-	-	-400	2.0	Latched Mode Command. Logic 1 indicates current command word is a mode code and selects MC0-MC4. Logic 0 indicates non-mode command and selects SA0-SA4.
18	-15V	-	-	-	-	-15V input power supply connection for the B channel transceiver.
19	GNDB	-	-	-	-	Ground B. Power supply return connection for the B channel transceiver.
20	TX/RX-B	-	-	-	-	Transmit/Receive transceiver-B. Input/output to the coupling transformer that connects to the B channel of the 1553 Bus.
21	Logic GND	-	-	-	-	Logic Ground. Power supply return for the digital logic section.
22	A01	(5)	-0.4	-400	3.6	Address Bit 1
23	A03	(5)	-0.4	-400	3.6	Address Bit 3
24	A05	(5)	-0.4	-400	3.6	Address Bit 5
25	A07	(5)	-0.4	-400	3.6	Address Bit 7
26	A09	(5)	-0.4	-400	3.6	Address Bit 9
27	A11	(5)	-0.4	-400	3.6	Address Bit 11
28	A13	(5)	-0.4	-400	3.6	Address Bit 13
29	A15	(5)	-0.4	-400	3.6	Address Bit 15 (MSB)
30	$\overline{\text{MEMOE}}$	-	-	-400	4.0	Memory Output Enable. A Logic 0 used to enable data output from memory when the 1553 or CPU reads from memory.
31	$\overline{\text{MEMENA-OUT}}$	-	-	-400	4.0	Memory Enable Out. Low level output to enable external RAM. Used with $\overline{\text{MEMOE}}$ to read data or with $\overline{\text{MEMWR}}$ to write data into external RAM.
32	CLOCK IN	± 20	± 0.02	-	-	Clock Input. 16 MHz TTL clock.
33	MEM/REG	(6)	-0.7	-	-	Memory/Register. Input from CPU to select memory or register data transfer.
34	$\overline{\text{STRBD}}$	(6)	-0.7	-	-	Strobe Data. Used in conjunction with $\overline{\text{SELECT}}$ to initiate a data transfer cycle to/from CPU.
35	$\overline{\text{EXTEN}}$	-	-	-	-	External Enable. Used to load data into external devices.
36	RD/WR	(6)	-0.7	-	-	Read/Write. Input from the CPU which defines the Data Bus transfer as a read or write operation.
37	$\overline{\text{EXTLD}}$	-	-	-	-	External load. Used to load data into external devices.
38	GNDA	-	-	-	-	Ground A. Power supply return connection for the A channel transceiver.
39	-15VA	-	-	-	-	-15V input power supply connection for the A channel transceiver.
40	TX/RX-A	-	-	-	-	Transmit/Receive transceiver-A. Input/Output to the coupling transformer that connects to the A channel of the 1553 Bus.
41	D01	(5)	-0.4	-400	3.6	I/O Data Bus Bit 1.
42	D03	(5)	-0.4	-400	3.6	I/O Data Bus Bit 3.
43	D05	(5)	-0.4	-400	3.6	I/O Data Bus Bit 5.
44	D07	(5)	-0.4	-400	3.6	I/O Data Bus Bit 7.

Table 7A – CT2553 Pin Function Table (78 Pin DIP) (continued)

Pin	Name	I _{IH} (μ A)	I _{IL} (mA)	I _{OH} (μ A)	I _{OL} (mA)	Description
45	D09	(5)	-0.4	-400	3.6	I/O Data Bus Bit 9.
46	D11	(5)	-0.4	-400	3.6	I/O Data Bus Bit 11.
47	D13	(5)	-0.4	-400	3.6	I/O Data Bus Bit 13.
48	D15	(5)	-0.4	-400	3.6	I/O Data Bus Bit 15 (MSB).
49	RTAD3	(5)	-0.4	-	-	Remote Terminal Address Bit 3.
50	RTAD2	(5)	-0.4	-	-	Remote Terminal Address Bit 2.
51	RTADP	(5)	-0.4	-	-	Remote Terminal Address Parity input.
52	SA/MC-2	-	-	-400	2.0	Subaddress/Mode Command Bit 2. B8 (MSB) counter.
53	SA/MC-4	-	-	-400	2.0	Subaddress/Mode Command Bit 4.
54	SA/MC-3	-	-	-400	2.0	Subaddress/Mode Command Bit 3.
55	THIS-RT	-	-	-400	2.0	Logic 0 pulse indicates receipt of a valid command word which contains the Remote Terminal address equivalent to the RTADO-RTAD4 inputs.
56	RTPARERR	-	-	-400	2.0	RTU (address) Parity Error. Logic 0 indicates RTU address parity (odd parity: RTADO-RTAD4, RTADP) has been violated.
57	T/R	-	-	-400	2.0	Transmit/Receive 1553 data. Latched T/R bit from current command word.
58	+5VB	-	-	-	-	+5V power supply connection for the B channel transceiver.
59	TX/RX-B	-	-	-	-	Transmit/Receive transceiver-B. Inverted I/O to coupling transformer that connects to channel B of the 1553 Bus.
60	A00	(5)	-0.4	-400	3.6	Address Bit 0 (LSB).
61	A02	(5)	-0.4	-400	3.6	Address Bit 2.
62	A04	(5)	-0.4	-400	3.6	Address Bit 4.
63	A06	(5)	-0.4	-400	3.6	Address Bit 6.
64	A08	(5)	-0.4	-400	3.6	Address Bit 8.
65	A10	(5)	-0.4	-400	3.6	Address Bit 10.
66	A12	(5)	-0.4	-400	3.6	Address Bit 12.
67	A14	(5)	-0.4	-400	3.6	Address Bit 14.
68	MEMWR	-	-	-400	4.0	Memory Write. Output pulse to write data into memory.
69	MEMENA-IN	± 20	± 0.02	-	-	Memory Enable In. Enables internal RAM only; connect directly to MEMENA-OUT.
70	INCMD	-	-	-400	2.0	In Command. Indicates BC or RTU currently in message transfer sequence.
71	MSTRCLR	(6)	-0.7	-	-	Master Clear. Power-on reset from CPU.
72	INT	-	-	-400	4.0	Interrupt. Interrupt pulse line to CPU.
73	IOEN	-	-	-400	4.0	Input/Output Enable. Output to enable external hybrid to the address/data bus.
74	SELECT	(6)	-0.7	-	-	Select. Input from the CPU. When active, selects CT2553 for operation.
75	READYD	-	-	-400	4.0	Ready Data. When active indicates data has been received from, or is available to, the CPU.
76	TAGEN	-	-	-400	4.0	Tag Enable. Enables an external time to counter for transferring the time tag word into memory.
77	+5VA	-	-	-	-	+5V input/power supply for channel A transceiver.
78	TX/RX-A	-	-	-	-	Transmit/Receive transceiver-A. Inverted I/O to the coupling transformer that connects to the A channel of the 1553 Bus.

1. I_{IH} is specified at: V_{CC} = 5.5V, V_{IH} = 2.7V.
2. I_{IL} is specified at: V_{CC} = 5.5V, V_{IL} = 0.4V.
3. I_{OH} is specified at: V_{CC} = 4.5V, V_{IH} = 2.4V.
4. I_{OL} is specified at: V_{CC} = 4.5V, V_{IH} = 0.4V.
5. Internal Pull-up Resistor = 30K Ohms, typ.
6. Internal Pull-up Resistor = 16K Ohms, typ.
7. Pin 13 = B6, Pin 15 = B7 and Pin 52 = B8 (MSB). B6, B7 and B8 are the MSB lines of an 8 BIT Counter used in the BC and MT mode to count 32 WORD TRANSFERS to memory (16 words received off the bus) for a total of 128 DATA and Tag words (in MT mode). (See pages 19 & 20 for discussion.)

Table 7B – CT2553 Pin Out Description (DIP)

1	D00	LOGIC GND	21
41	D01	A00	60
2	D02	A01	22
42	D03	A02	61
3	D04	A03	23
43	D05	A04	62
4	D06	A05	24
44	D07	A06	63
5	D08	A07	25
45	D09	A08	64
6	D10	A09	26
46	D11	A10	65
7	D12	A11	27
47	D13	A12	66
8	D14	A13	28
48	D15	A14	67
9	RTAD1	A15	29
49	RTAD3	MEMWR	68
10	RTAD0	MEMOE	30
50	RTAD2	MEMENA-IN	69
11	RTAD4	MEMENA-OUT	31
51	RTADP	INCMD	70
12	ILLCMD	CLOCK IN	32
52	SA/MC-2	MSTRCLR	71
13	SA/MC-0	MEM/REG	33
53	SA/MC-4	INT	72
14	LOGIC +5V	STRBD	34
54	SA/MC-3	IOEN	73
15	SA/MC-1	EXTEN	35
55	THIS-RT	SELECT	74
16	BCSTRCV	RD/WR	36
56	RTPARERR	READYD	75
17	LMC	EXTLD	37
57	T/R	TAGEN	76
18	-15VB	GND	38
58	+5VB	+5VA	77
19	GNDB	-15VA	39
59	TX/RX-B	TX/RX-A	78
20	TX/RX-B	TX/RX-A	40

CT2553
MIL-STD-1553
BUS Controller,
Remote Terminal and
BUS Monitor

Pin #	Function	Pin #	Function
1	D00	40	TX/RX-A
2	D02	41	D01
3	D04	42	D03
4	D06	43	D05
5	D08	44	D07
6	D10	45	D09
7	D12	46	D11
8	D14	47	D13
9	RTAD1	48	D15
10	RTAD0	49	RTAD3
11	RTAD4	50	RTAD2
12	ILLCMD	51	RTADP
13	SA/MC-0	52	SA/MC-2
14	LOGIC +5V	53	SA/MC-4
15	SA/MC-1	54	SA/MC-3
16	BCSTRCV	55	THIS-RT
17	LMC	56	RTPARERR
18	-15VB	57	T/R
19	GNDB	58	+5VB
20	TX/RX-B	59	TX/RX-B
21	LOGIC GND	60	A00
22	A01	61	A02
23	A03	62	A04
24	A05	63	A06
25	A07	64	A08
26	A09	65	A10
27	A11	66	A12
28	A13	67	A14
29	A15	68	MEMWR
30	MEMOE	69	MEMENA-IN
31	MEMENA-OUT	70	INCMD
32	CLOCK IN	71	MSTRCLR
33	MEM/REG	72	INT
34	STRBD	73	IOEN
35	EXTEN	74	SELECT
36	RD/WR	75	READYD
37	EXTLD	76	TAGEN
38	GND	77	+5VA
39	-15VA	78	TX/RX-A

Table 8 – CT2566 Pin Out Description (FP)

1	N/C		N/C	82
2	D00		LOGIC GND	81
3	D01		A00	80
4	D02		A01	79
5	D03		A02	78
6	D04		A03	77
7	D05		A04	76
8	D06		A05	75
9	D07		A06	74
10	D08		A07	73
11	D09		A08	72
12	D10		A09	71
13	D11		A10	70
14	D12		A11	69
15	D13		A12	68
16	D14		A13	67
17	D15		A14	66
18	RTAD1		A15	65
19	RTAD3		MEMWR	64
20	RTAD0		MEMOE	63
21	RTAD2		MEMENA-IN	62
22	RTAD4		MEMENA-OUT	61
23	RTADP		INCMD	60
24	ILLCMD		CLOCK IN	59
25	SA/MC-2		MSTRCLR	58
26	SA/MC-0		MEM/REG	57
27	SA/MC-4		INT	56
28	LOGIC +5V		STRBD	55
29	SA/MC-3		IOEN	54
30	SA/MC-1		EXTEN	53
31	THIS-RT		SELECT	52
32	BCSTRCV		RD/WR	51
33	RTPARERR		READYD	50
34	LMC		EXTLD	49
35	T/R		TAGEN	48
36	-15VB		GNDA	47
37	+5VB		+5VA	46
38	GNDB		-15VA	45
39	TX/RX-B		TX/RX-A	44
40	TX/RX-B		TX/RX-A	43
41	N/C		N/C	42

CT2553FP
MIL-STD-1553
BUS Controller,
Remote Terminal and
BUS Monitor

Pin #	Function	Pin #	Function
1	N/C	42	N/C
2	D00	43	TX/RX-A
3	D01	44	TX/RX-A
4	D02	45	-15VA
5	D03	46	+5VA
6	D04	47	GNDA
7	D05	48	TAGEN
8	D06	49	EXTLD
9	D07	50	READYD
10	D08	51	RD/WR
11	D09	52	SELECT
12	D10	53	EXTEN
13	D11	54	IOEN
14	D12	55	STRBD
15	D13	56	INT
16	D14	57	MEM/REG
17	D15	58	MSTRCLR
18	RTAD1	59	CLOCK IN
19	RTAD3	60	INCMD
20	RTAD0	61	MEMENA-OUT
21	RTAD2	62	MEMENA-IN
22	RTAD4	63	MEMOE
23	RTADP	64	MEMWR
24	ILLCMD	65	A15
25	SA/MC-2	66	A14
26	SA/MC-0	67	A13
27	SA/MC-4	68	A12
28	LOGIC +5V	69	A11
29	SA/MC-3	70	A10
30	SA/MC-1	71	A09
31	THIS-RT	72	A08
32	BCSTRCV	73	A07
33	RTPARERR	74	A06
34	LMC	75	A05
35	T/R	76	A04
36	-15VB	77	A03
37	+5VB	78	A02
38	GNDB	79	A01
39	TX/RX-B	80	A00
40	TX/RX-B	81	LOGIC GND
41	N/C	82	N/C

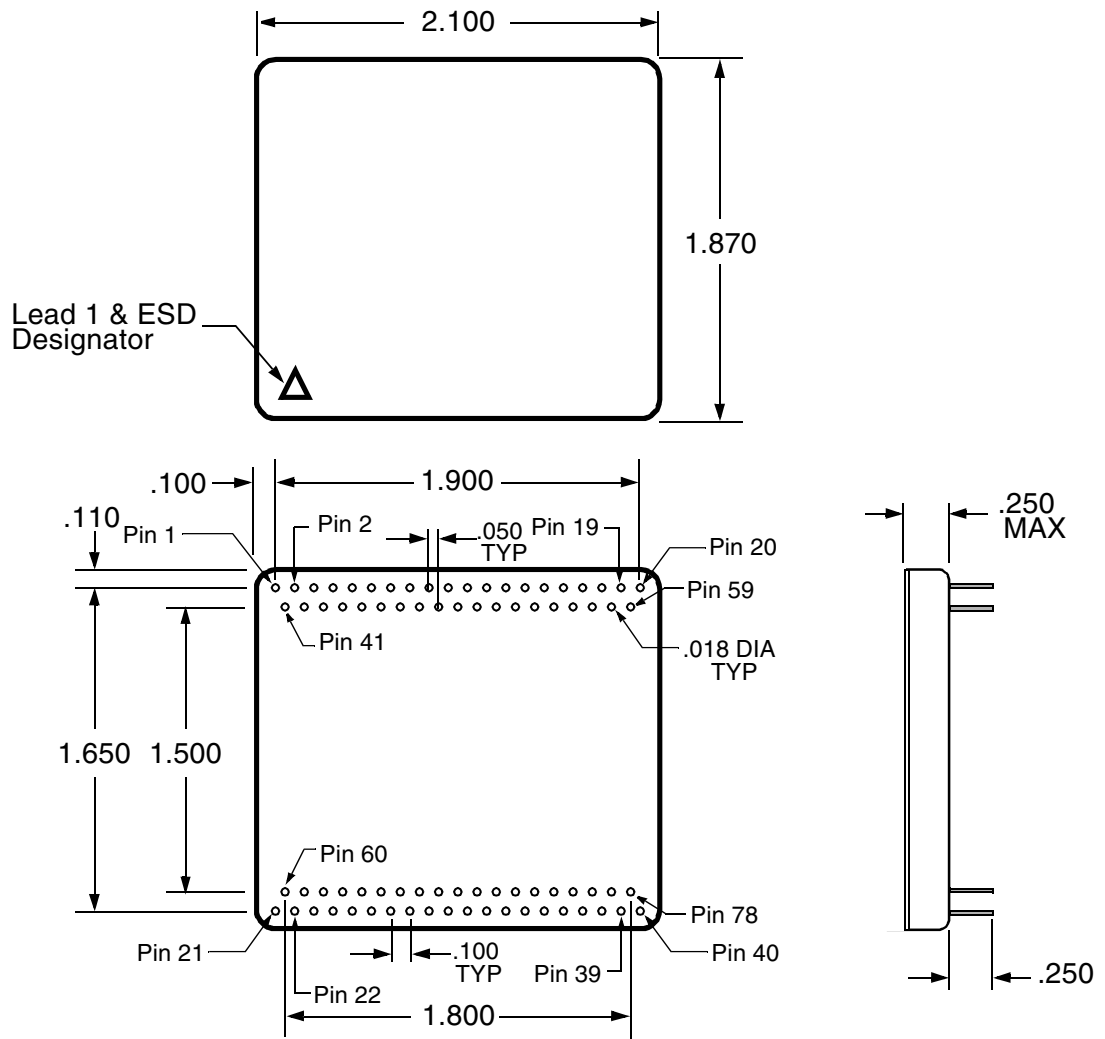

Figure 23 – Plug In Package Outline

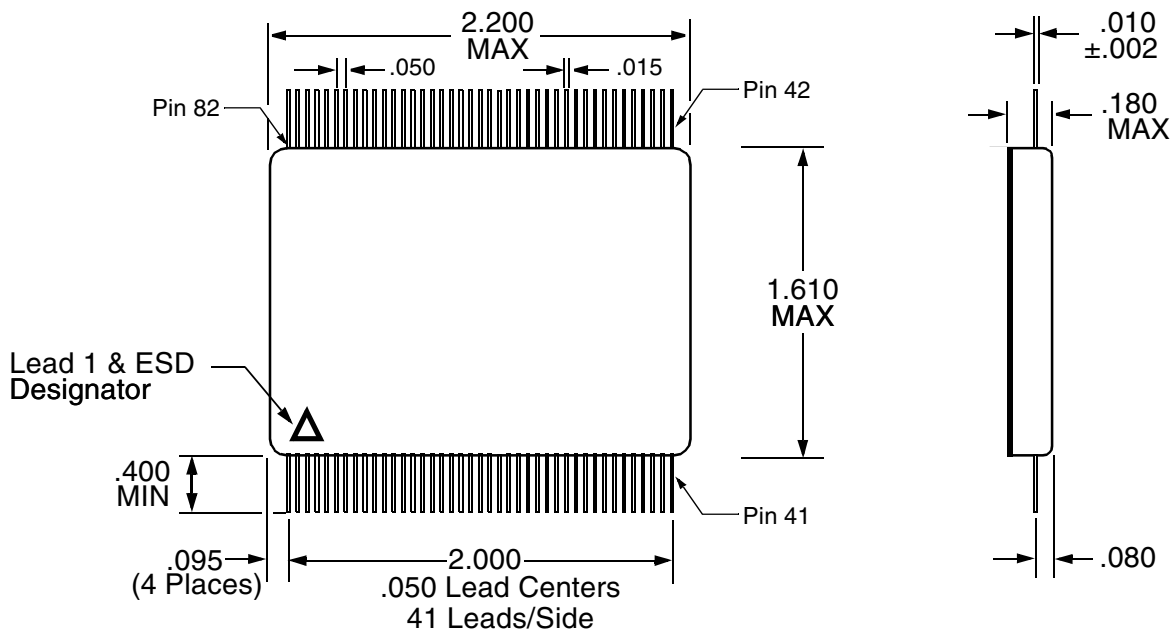

Figure 24 – Flat Package Outline



Ordering Information

Model Number	Screening	Power Supply	Package
CT2553	Military Temperature, -55°C to +125°C, Screened to the Individual Test Methods of MIL-STD-883	+5V, -15V	Plug in
CT2553-FP			Flat Package
CT2554		+5V, -12V	Plug in
CT2554-FP			Flat Package
* CT2555		+5V only	Plug in
* CT2555-FP			Flat Package
** CT2556			Plug in
** CT2556-FP			Flat Package

* Contact Factory

** Transceiverless – Contact Factory

Specifications subject to change without notice

Aeroflex Circuit Technology
35 South Service Road
Plainview New York 11803
www.aeroflex.com/act1.htm

Telephone: (516) 694-6700
FAX: (516) 694-6715
Toll Free Inquiries: (800) THE-1553
E-Mail: sales-act@aeroflex.com