

MITSUBISHI INSULATED GATE BIPOLAR TRANSISTOR

CT30VM-8

STROBE FLASHER USE

CT30VM-8

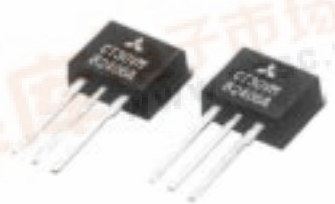

- VCES 400V
- ICM 180A

OUTLINE DRAWING Dimensions in mm

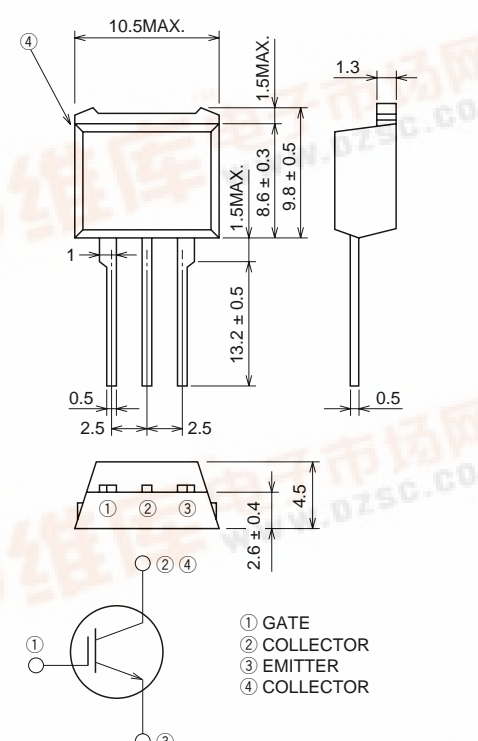

① GATE
② COLLECTOR
③ EMITTER
④ COLLECTOR

TO-220C

APPLICATION

Strobe Flasher.

MAXIMUM RATINGS (Tc = 25°C)

Symbol	Parameter	Conditions	Ratings	Unit
V _{CE} S	Collector-emitter voltage	V _{GE} = 0V	400	V
V _{GE} S	Gate-emitter voltage	V _{CE} = 0V, See notice 4	±30	V
V _{GEM}	Peak gate-emitter voltage	V _{CE} = 0V, t _w = 0.5s	±40	V
I _{CM}	Collector current (Pulsed)	See figure 1	180	A
T _j	Junction temperature		-40 ~ +150	°C
T _{stg}	Storage temperature		-40 ~ +150	°C

ELECTRICAL CHARACTERISTICS (T_j = 25°C)

Symbol	Parameter	Test conditions	Limits			Unit
			Min.	Typ.	Max.	
V _{(BR)CES}	Collector-emitter breakdown voltage	I _C = 1mA, V _{GE} = 0V	450	—	—	V
I _{CES}	Collector-emitter leakage current	V _{CE} = 400V, V _{GE} = 0V	—	—	10	μA
I _{GES}	Gate-emitter leakage current	V _{GE} = ±40V, V _{CE} = 0V	—	—	±0.1	μA
V _{GE(th)}	Gate-emitter threshold voltage	V _{CE} = 10V, I _C = 1mA	—	—	7.0	V



CT30VM-8

STROBE FLASHER USE

PERFORMANCE CURVES

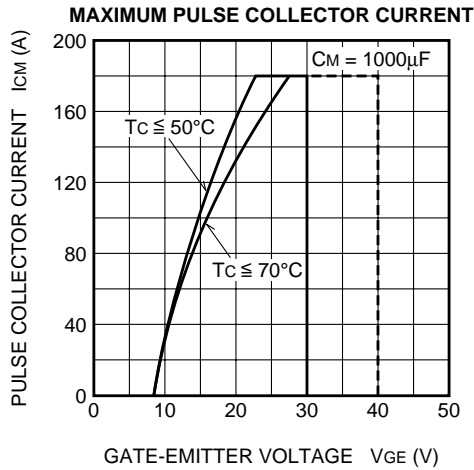

Figure 1

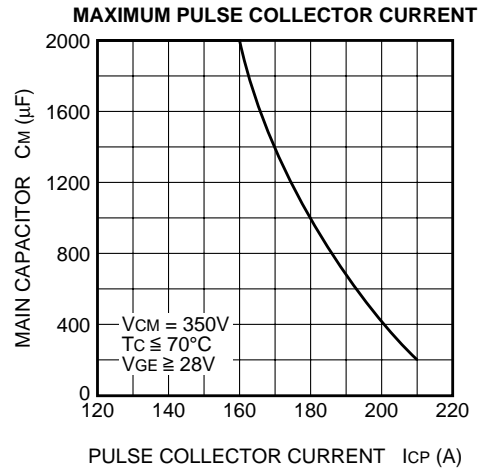
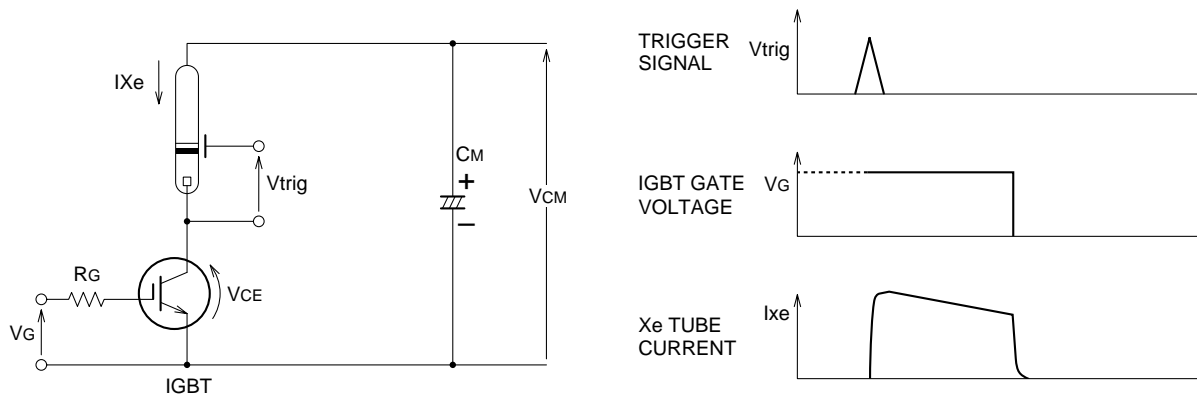

Figure 2

APPLICATION EXAMPLE



RECOMMEND CONDITION	MAXIMUM CONDITION
$V_{CM} = 330V$	360V
$I_P = 160A$	180A
$C_M = 800\mu F$	1000 μF
$V_{GE} = 28V$	

- Notice 1. Gate drive voltage during on-period must be applied to satisfy the rating of maximum pulse collector current. And reverse gate current during turn-off must be kept less than 1A. (In general, it is satisfied if $R_G \geq 30\Omega$)
- Notice 2. IGBT has MOS structure and its gate is insulated by thin silicon oxide. So please handle carefully not to suffer from electrostatic charge.
- Notice 3. The operation life should be endured 5,000 shots under the charge current ($I_{xe} \leq 180A$: full luminescence condition) of main condenser ($C_M=1000\mu F$). Repetition period under full luminescence condition is over 3 seconds.
- Notice 4. Total operation hours must be applied within 5,000 hours.