



# CRT Driver + DC Bias Amplifier

## Preliminary Data Sheet

### CVA1775N

#### FEATURES

- Little or No Heat Sink Required
- Ease of Use
- Rise Time ..... <8ns
- Fall Time ..... <7ns

#### APPLICATIONS

- 14", 15", 17" Monitors with 70KHz Scanning Frequency

#### DESCRIPTION

The CVA1775N includes a cascode CRT driver and a DC bias cutoff amplifier. All of the active components are inside the CVA1775N. Only the passive components and protection diodes are needed to drive a CRT tube. The CVA1775N can easily drive 70KHz monitors. With the unique feature of DC bias circuitry the printed circuit board will shrink as EMI performance will be improved.

#### ORDERING INFORMATION

Part	Package	Temperature
CVA1775N	16-PDIP	0°C to +110°C

#### SCHEMATIC, TEST CIRCUIT

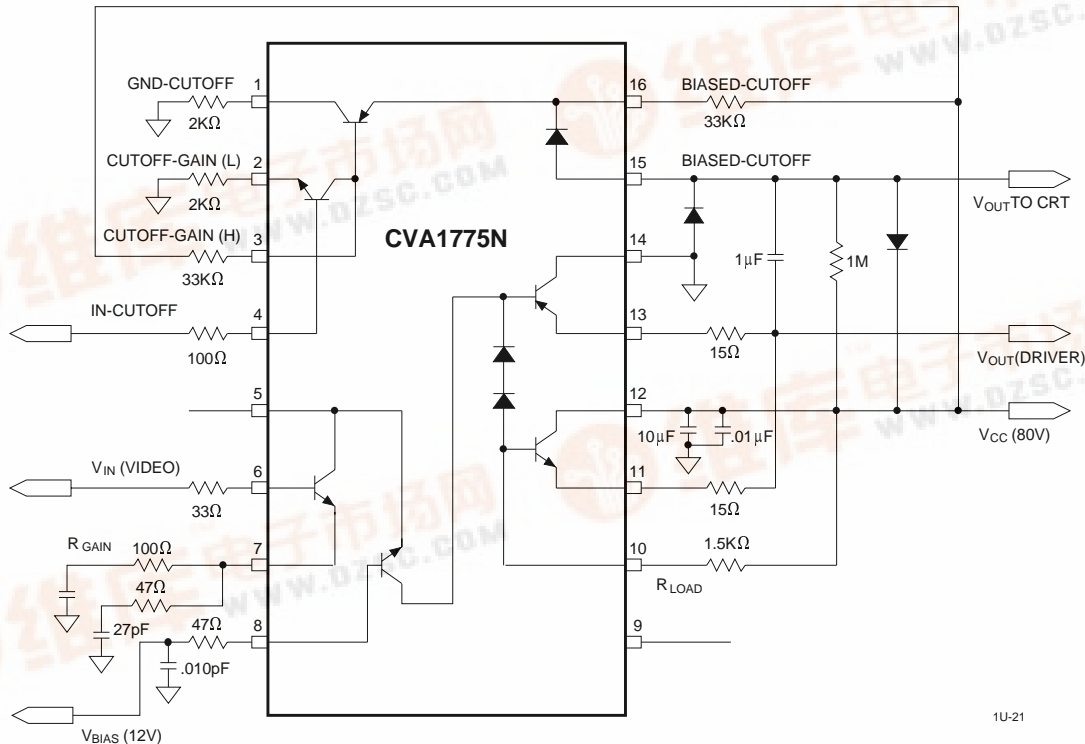

## ABSOLUTE MAXIMUM RATINGS

Supply Voltage (Driver Pin #12) . . . . .	100V	Junction Temperature . . . . .	175°C
Supply Voltage (cutoff) . . . . .	250V	Operating Temperature (Case) . . . . .	0°C to +110°C
Storage Temperature . . . . .	-25°C to +125°C	Lead Temperature . . . . .	+300°C

## CRT DRIVER DC ELECTRICAL CHARACTERISTICS $V_S = 80V, C_L = 12pF, V_{BIAS} = 12V, V_{IN} = 2.7V, R_L = 1500\Omega, T_{CASE} = +25^\circ C$ .

SYMBOL	CHARACTERISTICS	MIN	TYP	MAX	UNITS
$I_{CC}$	Supply Current		20	26	mA
$V_{OUT DC}$	Output DC Level	44	50	56	V
$A_v$ (Driver)	Voltage Gain		13	15	V

## CRT DRIVER AC ELECTRICAL CHARACTERISTICS $V_S = 80V, C_L = 12pF, V_{BIAS} = 12V, V_{IN} = 2.7V, R_L = 1500\Omega, T_{CASE} = +25^\circ C$ .

SYMBOL	CHARACTERISTICS	MIN	TYP	MAX	UNITS
$T_r$	Rise Time		7.5	9	ns
$T_f$	Fall Time		7.5	9	ns
$L_e$	Linearity		5		%
OS	Overshoot		3		%

## BIAS AMPLIFIER DC ELECTRICAL CHARACTERISTICS Supply Voltage = 150V, $V_B = 12V$ see test circuit.

SYMBOL	CHARACTERISTICS	TYP	MIN	MAX	UNITS	CONDITIONS
$I_{CC}$	Supply Current	5		5.5	mA	$V_{IN} = 5V$
$V_{OUT(Low)}$	Output Voltage	66	60	70	V	$V_{IN} = 5V$
$V_{OUT(HIGH)}$	Output Voltage	121	118	126	V	$V_{IN} = 1V$
Gain	Voltage Gain	13.8	12	16	V/V	$\Delta V_{OUT}/\Delta V_{IN}$
$\Delta$ Gain	Gain Match	0.5		1	dB	Note 1

Note 1. Calculate from voltage gain of each channel.

Note 2:  $V_{OUT}$  at  $V_{IN} = 5V, \Delta T = 25^\circ C$  100°C

**APPLICATION INFORMATION**

The CVA1775N is a high voltage driver and DC bias amplifier suitable for VGA, Super VGA, IBM® 8514, 1024 x 768 non-interlaced display applications. The CVA1775N features 80V and low power dissipation. The part is housed in the industry standard 16-pin PDIP.

**Thermal Considerations**

The transfer characteristics of the CVA1775N application are shown in *Figure 1*. Since this is a class A input stage, power supply current increases as the input signal increases and consequently power dissipation also increases.

The CVA1775N can be used without a heat sink. Under white screen condition, i.e. 25V output, dissipation is 0.6W/channel. Under gray level conditions  $C_L = 12\text{pf}$ ,  $V_{OUT} = 45\text{P-P}$ , the dissipation is 1.1W/channel.

The output of CVA1775N is not short circuit proof.

**FIGURE 1. CVA1775N DC CHARACTERISTICS**

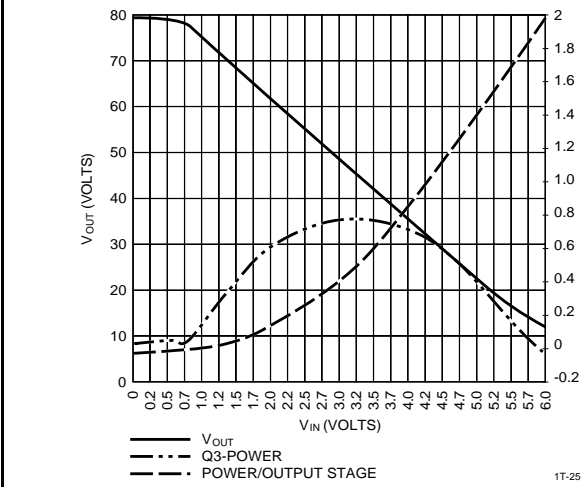

**TYPICAL CHARACTERISTICS**

