



# Improved Low Cost Triple CRT Driver

## CVA2411TX

### FEATURES

- Ease of Use
- Small Heat Sink
- OSD Option
- EMI Control Option
- Excellent Gray Scale Linearity

### APPLICATIONS

- CRT Displays for 1280 x 1024 Resolution with Pixel Clock Frequency up to 160MHz

### DESCRIPTION

The CVA2411TX is an improved low cost version that features excellent gray scale linearity with no crossover distortion and less EMI for 64KHz (horizontal scanning frequency) monitors. The CVA2411TX can be used with pre-amplifiers where the common emitter transistor is part of the pre-amp. With this device, OSD, peaking coil, and peaking capacitor can be available. A very small heat sink is required to pick-up ground from the standard TO220 package Tab. With 65MHz bandwidth, the device is an ideal low cost solution for 14", 15" and 17" monitors.

### ORDERING INFORMATION

| Part      | Package | Temperature     |
|-----------|---------|-----------------|
| CVA2411TX | T11A    | -20°C to +100°C |

### CONNECTION DIAGRAM AND SIMPLIFIED SCHEMATIC

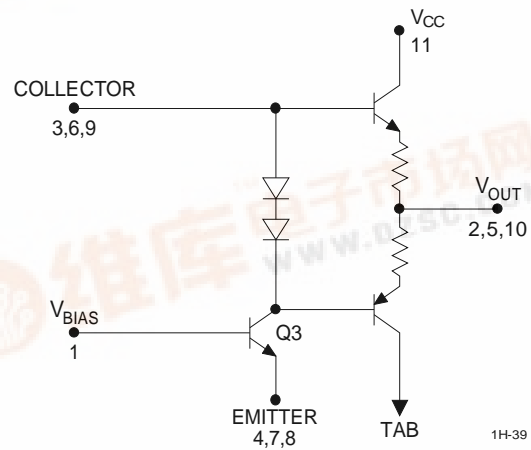
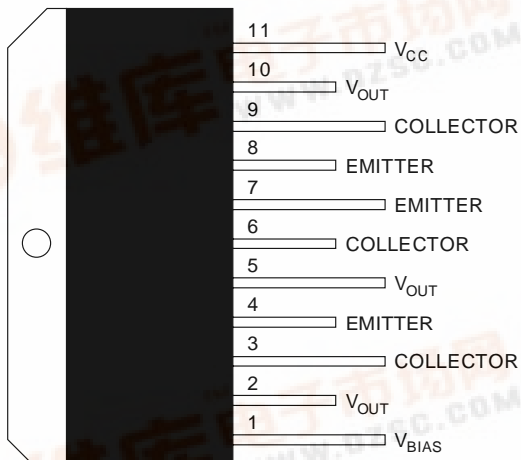

1B-17

### ABSOLUTE MAXIMUM RATINGS

Supply Voltage . . . . . 95V  
 Storage Temperature . . . . . -25°C to +100°C

Operating Temperature . . . . . -20°C to +100°C  
 Lead Temperature . . . . . +300°C

### DC ELECTRICAL CHARACTERISTICS $T_{CASE} = +25^{\circ}C$

| SYMBOL       | CHARACTERISTICS                                       | MIN | TYP | MAX  | UNITS |
|--------------|---|-----|-----|------|-------|
| $BV_{CEO}$   | Collector-Emitter Breakdown Voltage ( $I_c = 1mA$ )   | 95  |     |      | V     |
| $BV_{CBO}$   | Collector-Base Breakdown Voltage ( $I_c = 100\mu A$ ) | 100 |     |      | V     |
| $BV_{EBO}$   | Emitter-Base Breakdown Voltage ( $I_E = 100\mu A$ )   | 3   |     |      | V     |
| $H_{FE}$     | DC Current Gain ( $I_c = 35mA$ )                      | 30  | 50  |      | V     |
| $V_{BES}$    |   |     |     | 0.95 |       |
| $V_{CES}$    |   |     |     | 0.3  |       |
| $V_{BE(ON)}$ |   | 0.6 |     |      |       |
| $I_{CEO}$    |   |     |     | 100  | nA    |

### AC ELECTRICAL CHARACTERISTICS $T_{CASE} = +25^{\circ}C$

| SYMBOL   | CHARACTERISTICS                                 | MIN | TYP | MAX | UNITS |
|----------|---|-----|-----|-----|-------|
| $C_{ob}$ | Output Capacitance                              |     | 3   |     | pF    |
| $C_{cb}$ | Junction Capacitance                            |     | 2   |     | pF    |
| $C_{ib}$ | Input Capacitance                               |     | 8   |     | pF    |
| $f_t$    | Current Gain Bandwidth Product ( $I_c = 35mA$ ) |     | 150 |     | MHz   |

**FIGURE 1. TYPICAL CHARACTERISTICS**

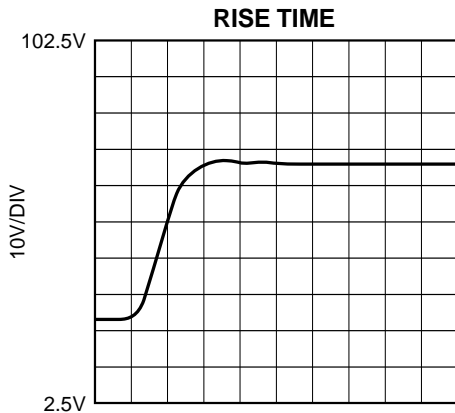

1J-8

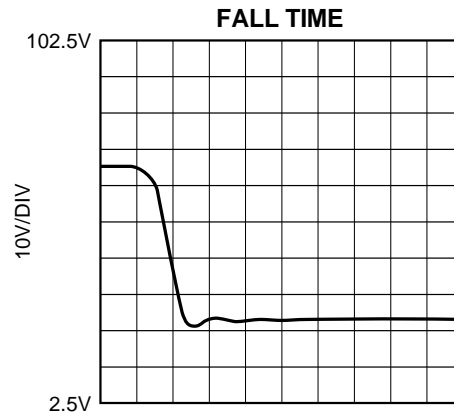

1J-9

**FIGURE 2. APPLICATION CIRCUIT**

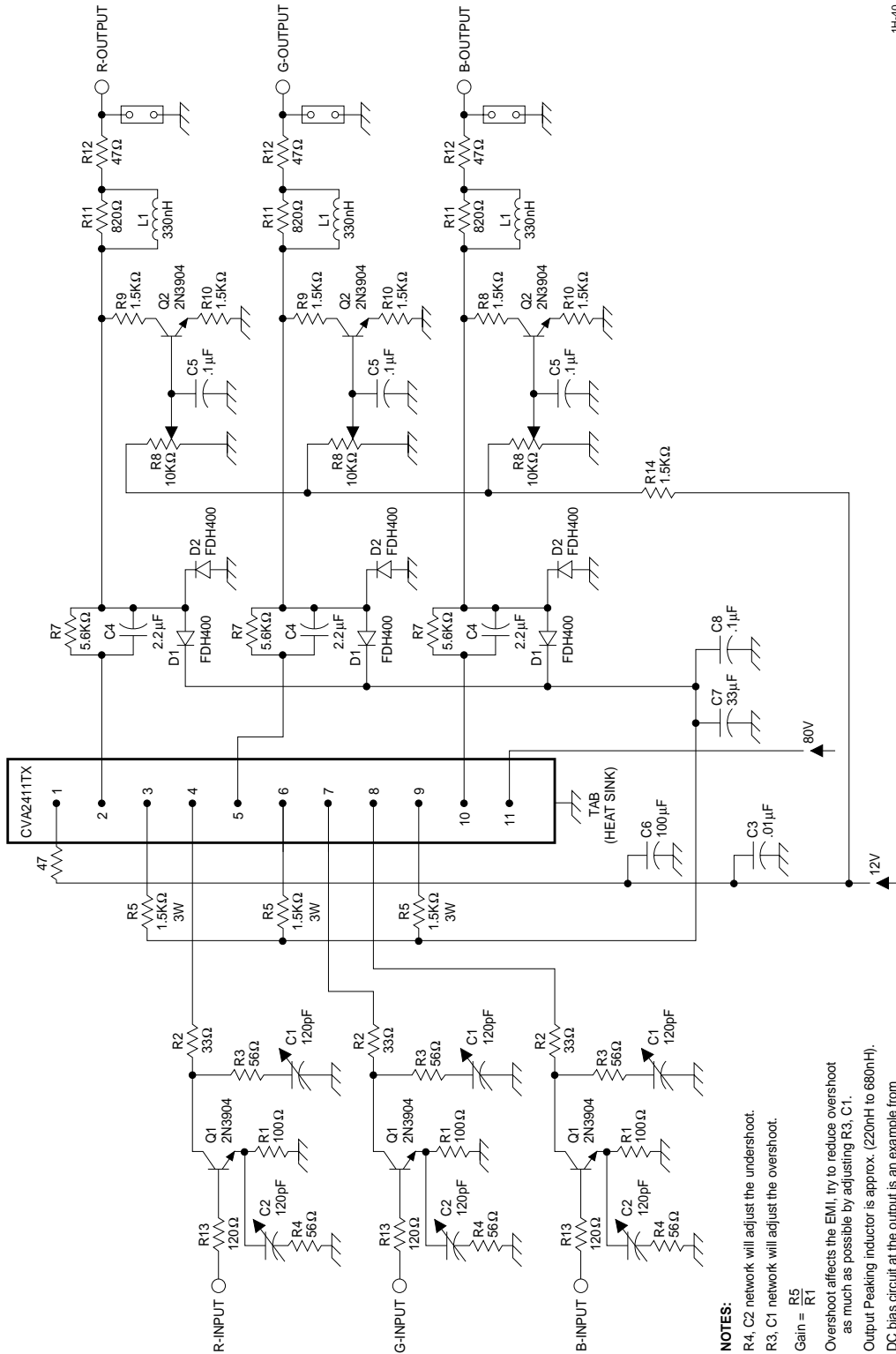

**NOTES:**  
 R4, C2 network will adjust the overshoot.  
 R3, C1 network will adjust the overshoot.  
 Gain = R1  
 Overshoot affects the EMI, try to reduce overshoot as much as possible by adjusting R3, C1.  
 Output Peaking inductor is approx. (220nH to 680nH).  
 DC bias circuit at the output is an example from several DC bias circuits available.

---

*CVA2411TX*

