



185MHz CRT Driver

CVA3424A / CVA3424

FEATURES

- Bandwidth 185MHz
- Rise/Fall Time..... 2.5ns
- Swing 40V_{P-P}
- Supply Voltage..... 80V

APPLICATIONS

- CRT Driver for 2000 x 1600, 1600 x 1280 and 1280 x 1024 Monitors

DESCRIPTION

The CVA3424 Family is a video driver amplifier designed specially to drive high resolution color monitors. With rise and fall time of under 2.5ns and 185MHz bandwidth, this device will provide excellent drive capability for the 2000 x 1600, 1600 x 1280 and 1280 x 1024 monitors.

ORDERING INFORMATION

Part	Package	Temperature
CVA3424AT	TO-220	-20°C to +90°C
CVA3424T	TO-220	-20°C to +90°C

CONNECTION DIAGRAM AND SIMPLIFIED SCHEMATIC

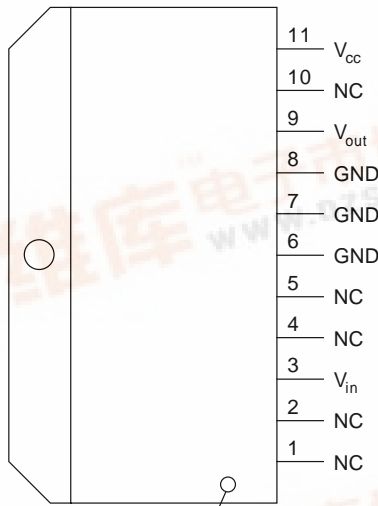

PIN 1 DESIGNATOR

T11A

1C-04

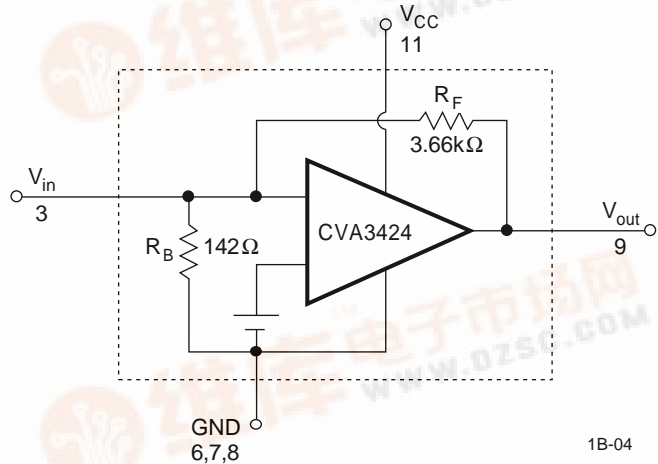

1B-04

ABSOLUTE MAXIMUM RATINGS

Supply Voltage 85V Operating Temperature -20°C to +90°C
 Storage Temperature -25°C to +100°C Lead Temperature +300°C

DC ELECTRICAL CHARACTERISTICS $V_S = 80V$, $C_L = 10pF$, $V_{out} = 40V_{p-p}$. See Figure 1. $T_A = +125^\circ C$ unless otherwise noted.

SYMBOL	CHARACTERISTICS	MIN	TYP	MAX	UNITS
I_{CC}	Supply Current		45	55	mA
V_{inDC}	I_{put} DC Level	1.4	1.6	1.8	V
V_{outDC}	Output DC Level	34	40	46	V
A_V	Voltage Gain	11	13	15	V
	Gain Matching		0.2		dB

AC ELECTRICAL CHARACTERISTICS $V_S = 80V$, $C_L = 10pF$, $V_{out} = 40V_{p-p}$. See Figure 1. $T_A = +125^\circ C$ unless otherwise noted.

SYMBOL	CHARACTERISTICS	CVA3424A			CVA3424			UNITS
		MIN	TYP	MAX	MIN	TYP	MAX	
t_r	Rise Time		2.2	2.9		2.5	3.5	ns
t_f	Fall Time		2.5	2.9		2.7	3.5	ns
BW	Bandwidth		185			150		MHz
Le	Linearity		5			5		%
OS / US	Overshoot / Undershoot		8			8		%

FIGURE 1. TEST CIRCUIT

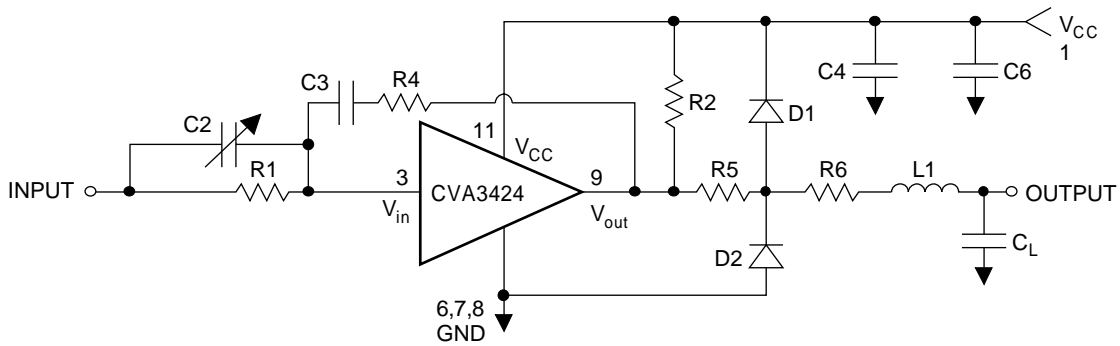

- | | | | |
|-------------------------|---|-------------------------------------|--------------|
| $R1 = 270 \Omega$ | $C2 = \text{Variable } 4 \text{ to } 150pF$ | $C6 = 0.01 \mu f/160V$ | $D1 = DS464$ |
| $R2 = 12k \Omega (1 W)$ | Typical $27pF$ | $C_L = 10pF$ (Including Parasitics) | $D2 = DS464$ |
| $R4 = 300k \Omega$ | $C3 = 46pF$ | | $L1 = 150nH$ |
| $R5 = 15 \Omega$ | $C4 = 10 \mu f/160V$ | | |
| $R6 = 15 \Omega$ | | | |

APPLICATIONS INFORMATION

Basic Circuit Configuration

The CVA3424 is a transimpedance amplifier with two stage feedback amplifier configurations. Any change in input current will be reflected as change in output voltage swing. A resistor in series with the input will change the CVA3424 into a voltage amplifier. The output is an emitter follower. Because of the complementary circuitry employed, there is no need for load or pull up resistor.

An internally bypassed capacitor is included inside the package, however, for low frequencies an electrolytic capacitor is recommended.

CVA3424 has an internal feedback resistor of 3.66KΩ. In the absence of any input signal, the V_{out} DC is set by

$$V_{out}(DC) = (1 + \frac{R_F}{R_B}) V_{in}(DC)$$

If an input signal is applied, the gain is set by

$$V_{out} = (\frac{R_F}{R_x}) V_{in}$$

Input and Transfer Characteristics

An input current swing of ±4.5mA causes the output to change by ±25V.

A resistor of 270Ω in series with the input will give a voltage gain of -13.

Input pins are internal dc feedback nodes and thus have low impedances. These pins must be fed from a series RC network for high frequency emphasis.

Output Characteristics

The CVA3424 is intended to be used as the final stage of very fast video circuits. The nominal load capacitance is 10pF. Other values can be accommodated since the output stage is an emitter follower and is fairly insensitive to load capacitance. However, a wire connection of some length is unavoidable, that causes objectionable ringing due to a resonant circuit. To avoid this a damping resistor must be used in series with the lead inductance. Also a resistor is necessary to protect the amplifier against arcing. A resistor of 30-50Ω will provide protection but will slow down the response. The lead inductance may be artificially increased by a tenth of a microHenry to obtain desired peak. Any change in inductance will require readjustment of damping resistor, as stated by equation (1).

$$R^* = \sqrt{\frac{L}{C}} \quad (1)$$

The output of CVA3424 is not short circuit proof. Any resistance to $V+$ or Ground should be >600Ω.

Thermal Characteristics

When low frequency square waves are amplified, some droop will occur due to a large change in thermal dissipation in the input transistors. To overcome this an R-C series feedback network is suggested with 300kΩ and 46pF values. Under normal operating conditions the CVA3424 will dissipate up to 6W. The maximum allowed case temperature is +90°C. To calculate maximum heatsink thermal resistance use equation (2).

$$R_{th} = \frac{(90 - 50^\circ)}{6W} = 6.7^\circ C/W$$

