

SONY

CXA1600M/P

8-pin Single-chip AM Radio with Built-in Power Amplifier

Description

The CXA1600M/P is an 8-pin single-chip bipolar IC for AM radios. This IC includes all functions from the front-end to the power amplifier.

The CXA1600M/P doesn't require any external filter, making external ceramic filter attachment unnecessary.

Features

- EIAJ output=100 mW (typ.)
($V_{CC}=3\text{ V}$, $R_L=8\ \Omega$)
- Built-in electrical volume control.
- No ceramic filter required.
- Few peripheral components.

Applications

AM radio

Structure

Bipolar silicon monolithic IC

Block Diagram

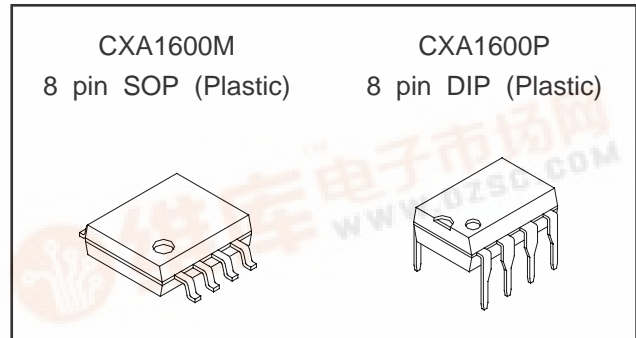
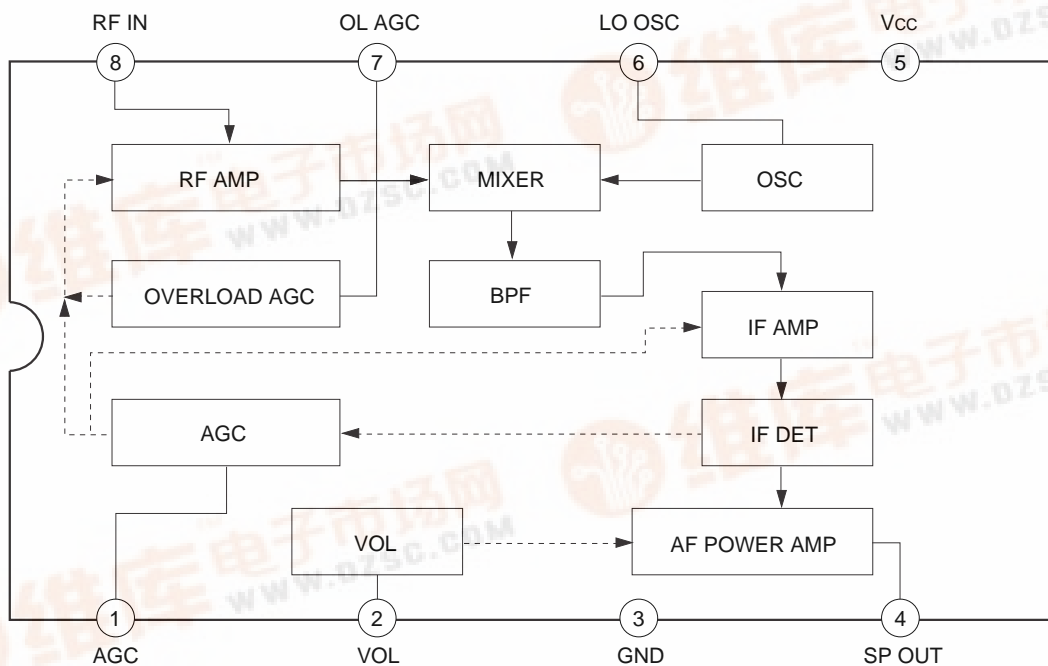

Absolute Maximum Ratings (Ta=25 °C)

- | | | | |
|-------------------------|-----------|-------------|----|
| • Supply voltage | V_{CC} | 7 | V |
| • Operating temperature | T_{opr} | -20 to +75 | °C |
| • Storage temperature | T_{stg} | -65 to +150 | °C |

Operating Conditions

- | | | | |
|----------------|----------|------------|---|
| Supply voltage | V_{CC} | 1.8 to 4.5 | V |
|----------------|----------|------------|---|

Sony reserves the right to change products and specifications without prior notice. This information does not convey any license by any implication or otherwise under any patents or other right. Application circuits shown, if any, are typical examples illustrating the operation of the devices. Sony cannot assume responsibility for any problems arising out of the use of these circuits.

Pin Description

Vcc=3 V

No.	Symbol	Voltage (typ.)	Equivalent Circuit	Description
1	AGC	0.61 V		Connect with a capacitor.
2	VOL	0.1 V		Connect to the midpoint of the volume control.
3	GND	0 V		Ground
4	SP OUT	1.28 V		Audio output. Connect with a capacitor.
5	Vcc	3 V		Power supply
6	LO OSC	Vcc		Oscillation output. Connect with an oscillation coil.

No.	Symbol	Voltage (typ.)	Equivalent Circuit	Description
7	OL AGC	0.62 V		Connect with a capacitor.
8	RF IN	3 V		RF input. Connect with the antenna circuit.

Electrical Characteristics

V_{CC}=3 V, T_a=25 °C

Item	Test conditions	Min.	Typ.	Max.	Unit
1 Non-signal circuit current	No signal	4.8	6	10	mA
2 EIAJ output (with 8 Ω load)	f=1 MHz, f _{MOD} =1 kHz, 30 % V _{in} =90 dBμV	80	100		mW
3 Volume attenuation	f=1 MHz, f _{MOD} =1 kHz, 30 % V _{in} =90 dBμV, Volume=minimum		-70	-65	dBm
4 Overall noise level	Short circuit at RF IN with a 1μF capacitor. Measure the level at SP OUT. Volume=maximum		-25	-15	dBm
5 Selectivity	f=1.010 MHz, f _{MOD} =1 kHz, 30 % V _{in} =35 dBμV.	14	19		dB

AM I/O Characteristics

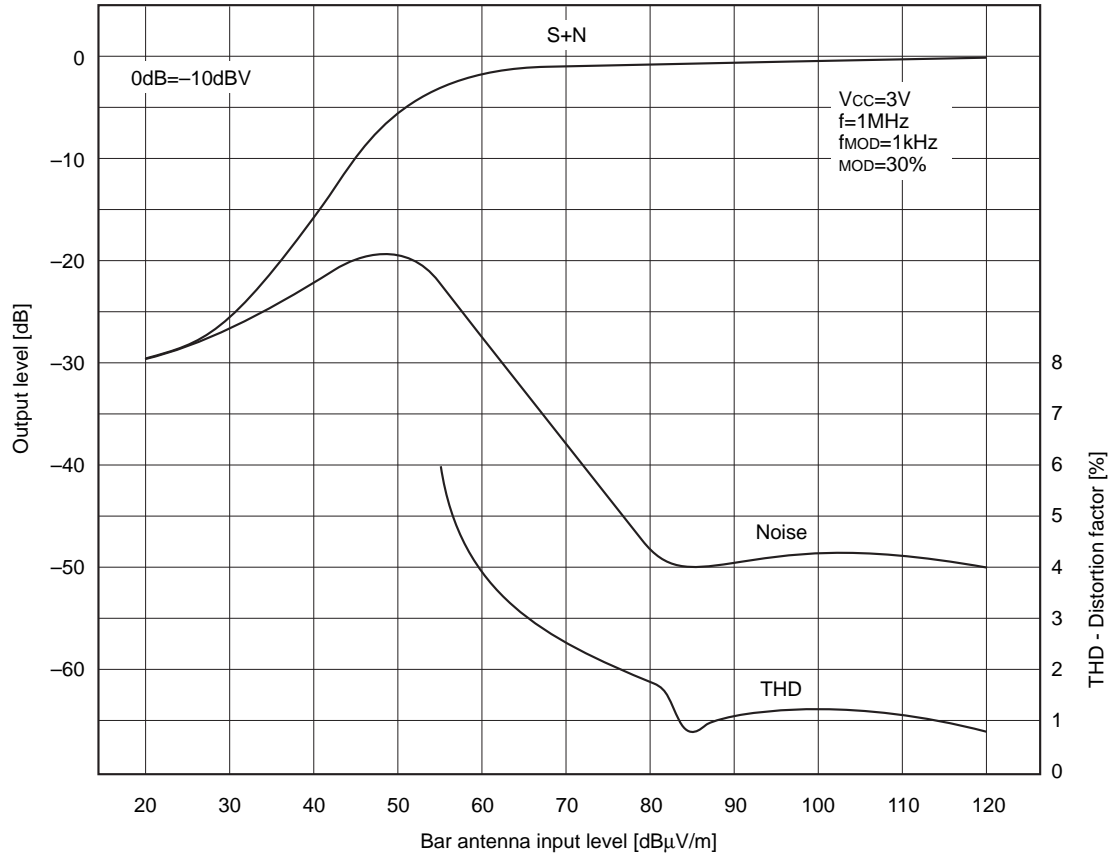

Selectivity Characteristics

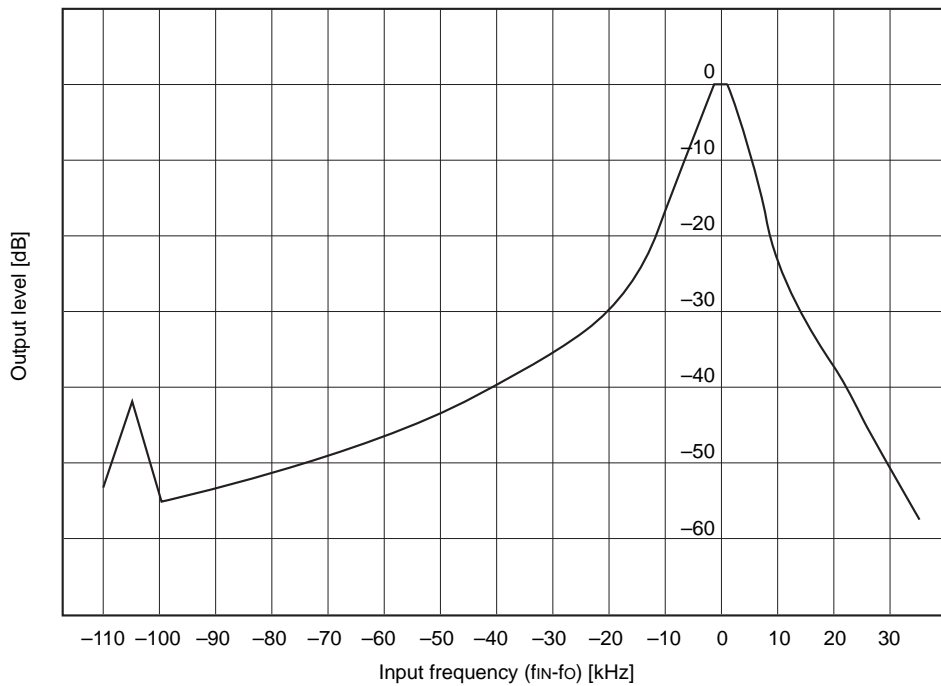

Notes on Applications

Application 1

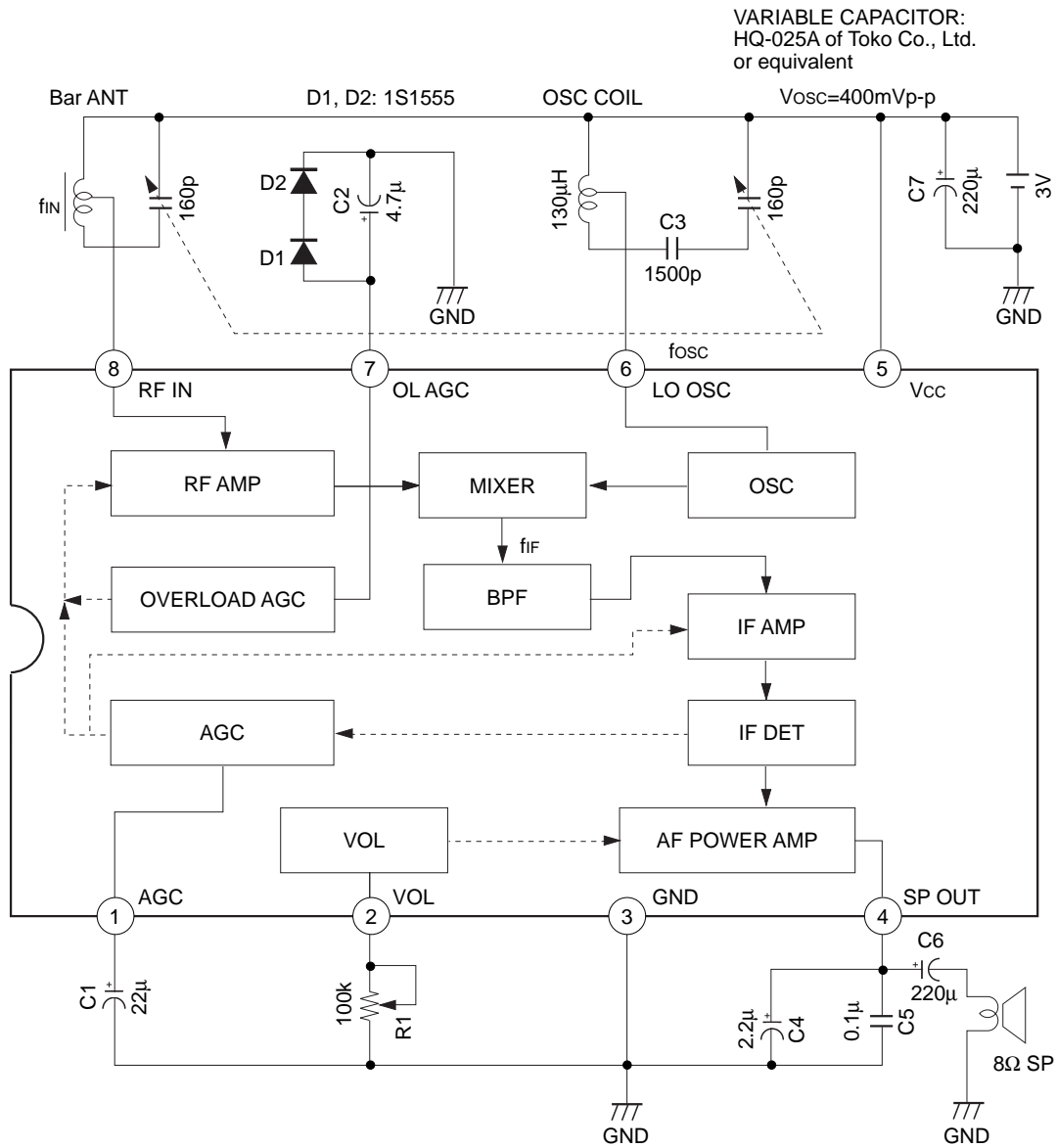

The CXA1600M/P operates on the new system using very low intermediate frequency (approx. 55 kHz). (Actual IF frequency is determined by internal B.P.F.fo.)

$$f_{IF} = \frac{1}{2} f_{OSC} - f_{IN} \approx 55 \text{ kHz}$$

Please take care of choice of the coil and variable capacitor as follows. (See next page.)

Coil data

Application 1

AM OSC

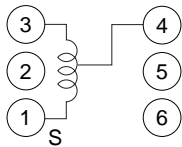

Wire diameter \varnothing 0.08 mm 2UEW

f (kHz)	L (μ H)	Qo	Number of windings (μ H)	
			1 to 4	4 to 3
796	130	70	32.5	97.5

AM Bar Antenna

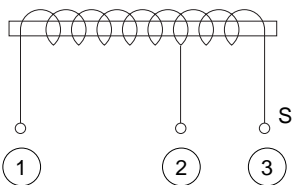

f (kHz)	L (μ H)	3 to 2	2 to 1
796	560	140	420

Application 2

AM OSC

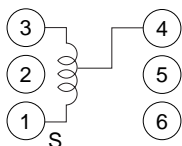

Wire diameter \varnothing 0.08 mm 2UEW

f (kHz)	L (μ H)	Qo	Number of windings (μ H)	
			1 to 4	4 to 3
796	210	70	71.3	138.7

AM Bar Antenna

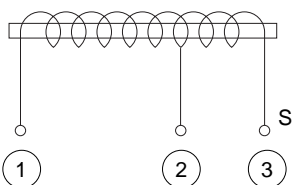

f (kHz)	L (μ H)	3 to 2	2 to 1
796	900	180	720

Application Circuit 1 VARIABLE CAPACITOR used (Equivalent capacitor)

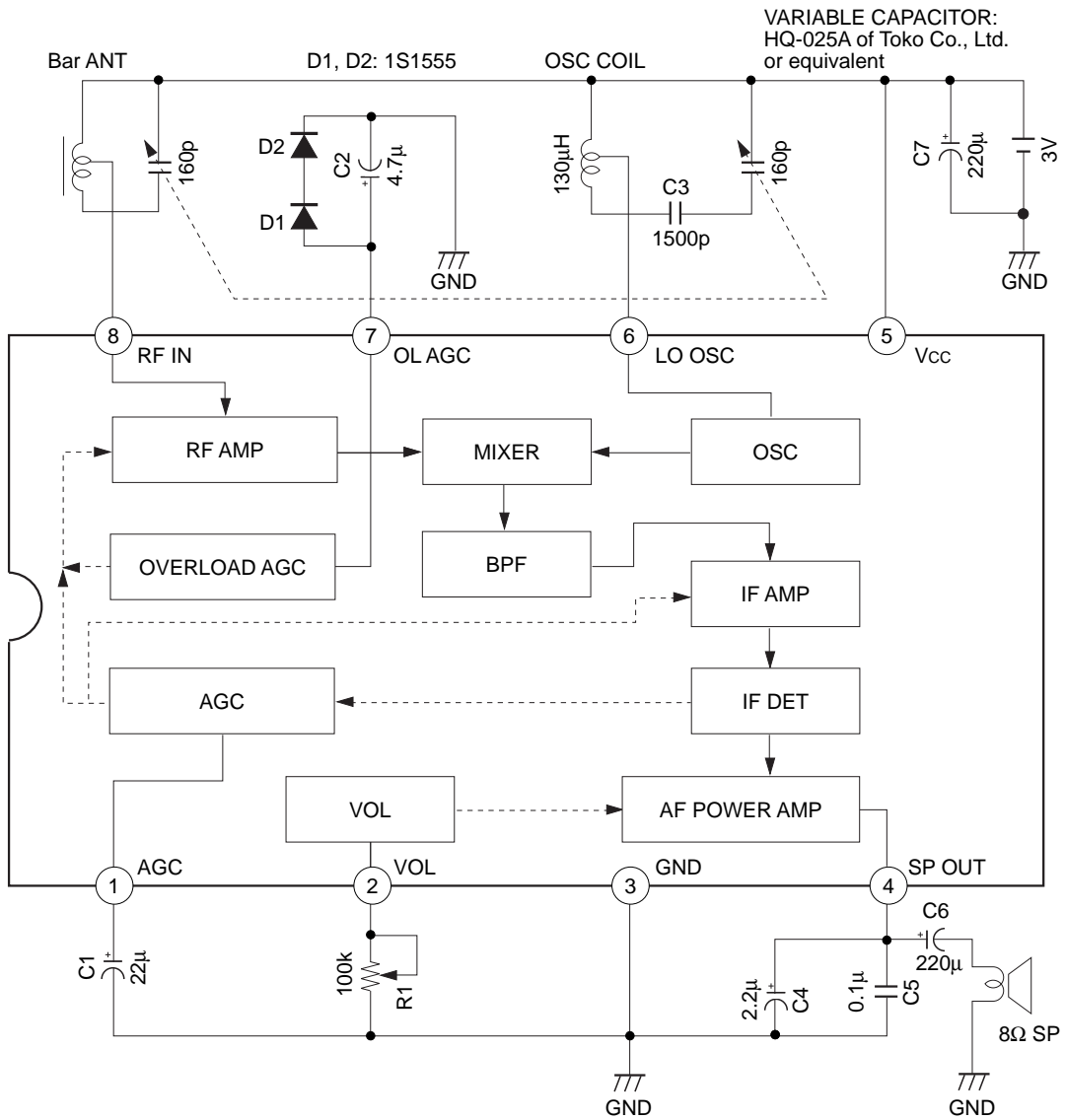

Application circuits shown are typical examples illustrating the operation of the devices. Sony cannot assume responsibility for any problems arising out of the use of these circuits or for any infringement of third party patent and other right due to same.

Application Circuit 2 VARIABLE CAPACITOR used (Non-Equivalent capacitor)

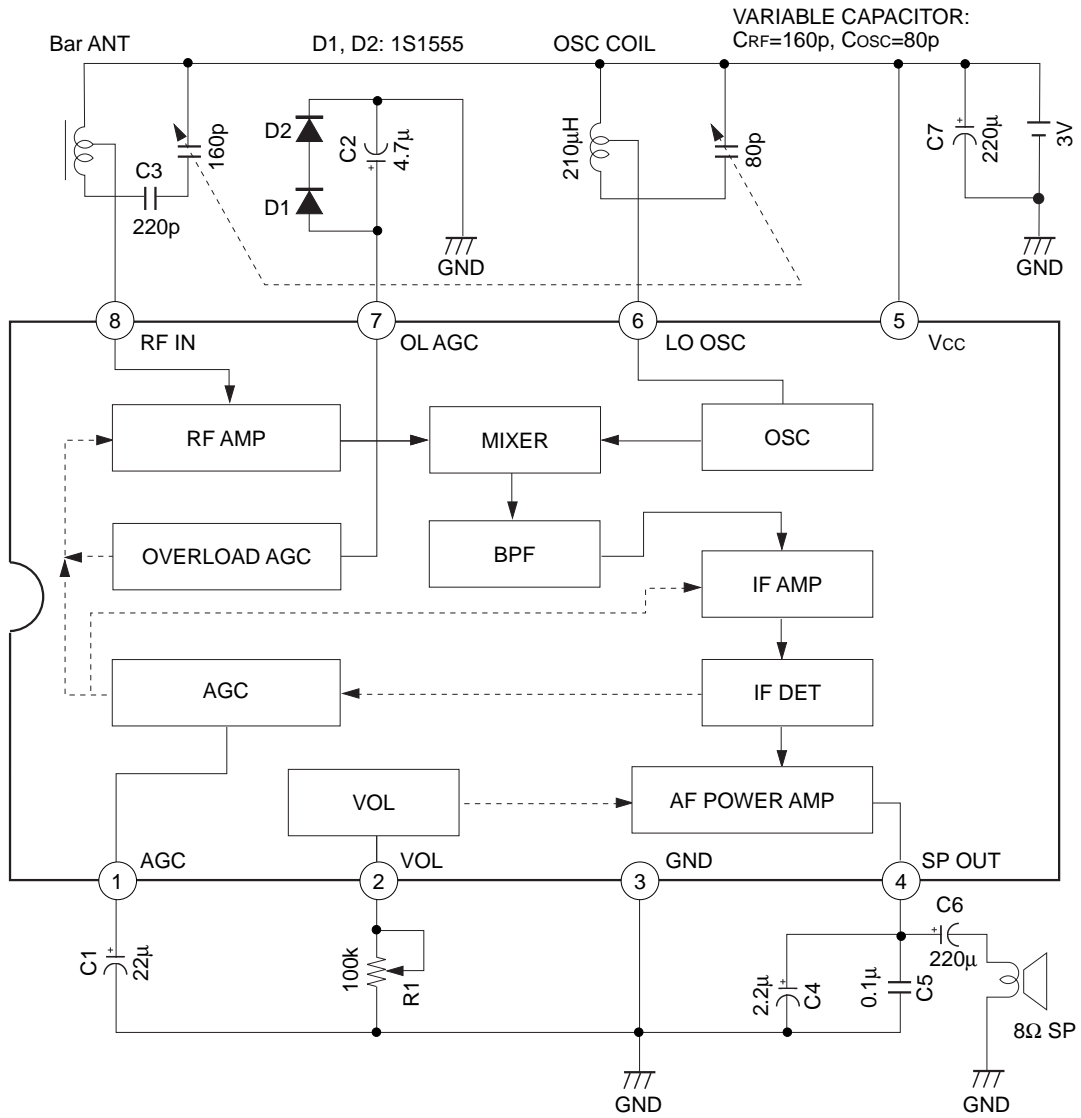

Application circuits shown are typical examples illustrating the operation of the devices. Sony cannot assume responsibility for any problems arising out of the use of these circuits or for any infringement of third party patent and other right due to same.

Package Outline Unit : mm

CXA1600M

8PIN SOP (PLASTIC)

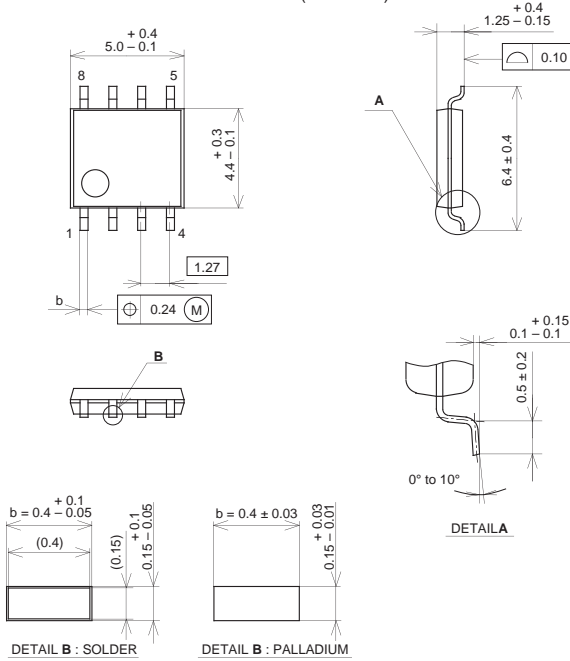

PACKAGE STRUCTURE

SONY CODE	SOP-8P-L03
EIAJ CODE	SOP008-P-0225
JEDEC CODE	

PACKAGE MATERIAL	EPOXY RESIN
LEAD TREATMENT	SOLDER/PALLADIUM PLATING
LEAD MATERIAL	42/COPPER ALLOY
PACKAGE MASS	0.1g

NOTE : PALLADIUM PLATING

This product uses S-PdPPF (Sony Spec.-Palladium Pre-Plated Lead Frame).

CXA1600P

8PIN DIP (PLASTIC)

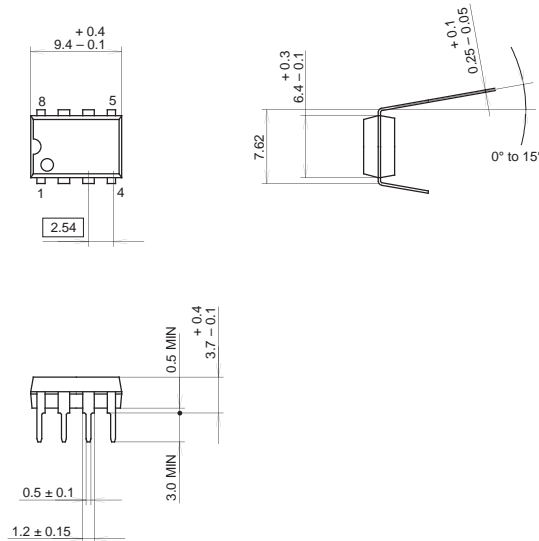

PACKAGE STRUCTURE

SONY CODE	DIP-8P-01
EIAJ CODE	DIP008-P-0300
JEDEC CODE	

PACKAGE MATERIAL	EPOXY RESIN
LEAD TREATMENT	SOLDER PLATING
LEAD MATERIAL	COPPER ALLOY
PACKAGE MASS	0.5g