

**SONY**

# CXA1634P/M

## Pre-Power Amplifier for Pocketable Stereo Cassette Player

### Description

The CXA1634P/M is a bipolar IC designed for headphone stereos. It provides such functions as pre-amplifier, DC volume control, bass boost, headphone driver and others:

### Features

- Pre-amplifier, volume control, headphone driver
- Bass boost function
- Wide operating voltage (1.8 to 6.5V)
- Few external parts

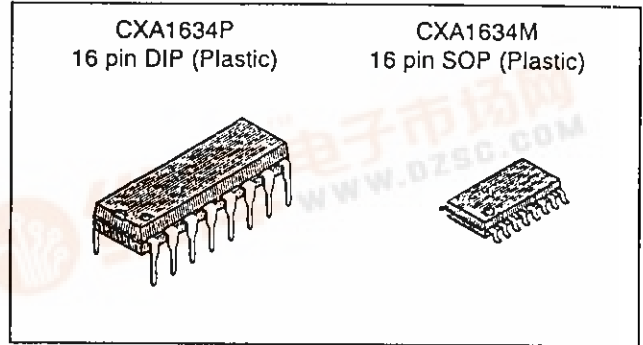

### Application

Headphone stereo

### Structure

Bipolar silicon monolithic IC

### Absolute Maximum Ratings (Ta=25°C)

- |                               |                  |            |               |
|-------------------------------|------------------|------------|---------------|
| • Supply voltage              | V <sub>CC</sub>  | 7          | V             |
| • Operating temperature       | T <sub>opr</sub> | -20 to +75 | °C            |
| • Storage temperature         | T <sub>stg</sub> | -65 to +10 | °C            |
| • Allowable power dissipation | P <sub>d</sub>   | 730        | mW (CXA1634P) |
|                               |                  | 500        | mW (CXA1634M) |

### Recommended Operating Condition

- |                |                 |            |   |
|----------------|-----------------|------------|---|
| Supply voltage | V <sub>CC</sub> | 1.8 to 6.5 | V |
|----------------|-----------------|------------|---|

### Block Diagram and Pin Configuration

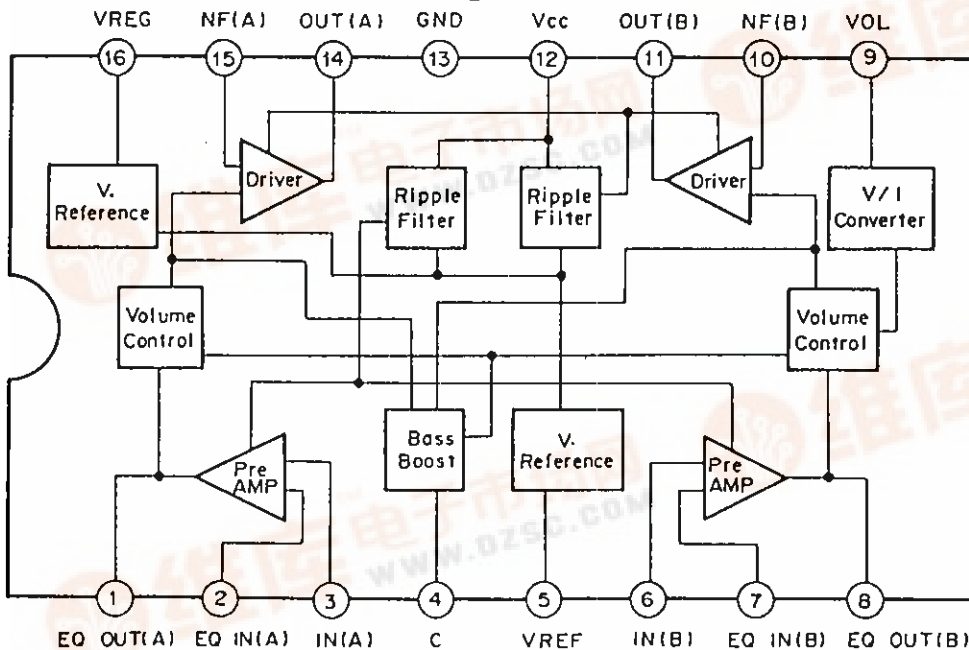

Sony reserves the right to change products and specifications without prior notice. This information does not convey any license by any implication or otherwise under any patents or other right. Application circuits shown, if any, are typical examples illustrating the operation of the devices. Sony cannot assume responsibility for any problems arising out of the use of these circuits.



Pin Description

(Pin voltage is  $V_{cc}=3.0V$ , at no signal)

Pin No.	Symbol	Pin voltage (Typ.)	Equivalent circuit	Description
1 8	EQ OUT (A) EQ OUT (B)	1.6V		Pre-amplifier output and equalizer circuit connection
2 7	EQ IN (A) EQ IN (B)	1.5V		Equalizer circuit input
3 6	IN (A) IN (B)	1.5V		Pre-amplifier output
4	C	1.5V		Bass boost time constant

Pin No.	Symbol	Pin voltage (Typ.)	Equivalent circuit	Description
5	VREF	1.5V		Reference bias voltage
9	Vol IN	1.5V		Vol control voltage input
10 15	NF (A) NF (B)	1.1V		Filter time constant
11 14	OUT (A) OUT (B)	1.1V		Headphone driver output

Pin No.	Symbol	Pin voltage (Typ.)	Equivalent circuit	Description
12	Vcc	3.0V		Supply voltage input
13	GND	0V		GND
16	VREG	2.76V	<p>The diagram shows a circuit for pin 16 (VREG). It features a 3.0V Vcc supply at the top. A series of components from Vcc to ground are: a diode pointing down, an 8K resistor, a 5K resistor, a diode pointing up, a 42K resistor, and a 50K resistor. A 25µA current source is connected to ground. The output of the circuit is taken from the node between the 5K resistor and the 42K resistor, which is labeled with a circled 16.</p>	Power supply filter

**Electrical Characteristics** (Ta=25°C, Vcc=3.0V, fo=1kHz, volume 100% unless noted otherwise)

Item	Symbol	SW conditions				Input point	Conditions	Test point	Min.	Typ.	Max.	Unit
		S1	S2	S3	S4							
Circuit current	I <sub>CC</sub>	2	OFF	1	2	—	No signal	I <sub>CC</sub>	7	10	15	mA
Voltage gain 1	GV1	1	ON	↓		V <sub>IN</sub>	V <sub>IN</sub> =-75dBm	V <sub>OUT</sub>	62	65	68	dB
Voltage gain 2	GV2			2	↓	V <sub>IN</sub>	V <sub>IN</sub> =-75dBm, vol=50%	V <sub>OUT</sub>	51	54	58	dB
Voltage gain 3	GV3	↓	↓	1	1	V <sub>IN</sub>	V <sub>IN</sub> =-75dBm, B.B. ON	V <sub>OUT</sub>	64	67	69	dB
Channel balance 1	Δ GV1					—		—	-1.5	0	1.5	dB
Channel balance 2	Δ GV2					—		—	-1.5	0	1.5	dB
Channel balance 3	Δ GV3					—		—	-1.5	0	1.5	dB
Volume maximum attenuation	V <sub>MIN</sub>	1	ON	3	1	V <sub>IN</sub>	V <sub>IN</sub> =-65dBm	V <sub>OUT</sub>	51	—	—	dB
Maximum output	P <sub>OMAX</sub>			1		V <sub>IN</sub>	R <sub>L</sub> =32Ω, THD=10%	V <sub>OUT</sub>	25	30		mW
Distortion factor 1	THD1			↓		V <sub>IN</sub>	V <sub>IN</sub> =-70dBm	V <sub>OUT</sub>	—	0.7	1.2	%
Distortion factor 2	THD2			2		V <sub>IN</sub>	V <sub>IN</sub> =-60dBm, vol=50%	V <sub>OUT</sub>	—	0.5	1.0	%
Noise output	V <sub>ND</sub>			1		—	V <sub>IN</sub> is R <sub>g</sub> =2kΩ termination	V <sub>OUT</sub>	—	—	-47	dBm
Ripple output	V <sub>R</sub>					V <sub>CC</sub>	V <sub>CC</sub> =2.5V, ΔV <sub>R</sub> =-30dBm	V <sub>OUT</sub>	—	—	-44	dBm
Cross talk A → B	V <sub>CT1</sub>	↓	↓	↓	↓	V <sub>IN</sub>	A: V <sub>IN</sub> =-65dBm B: V <sub>IN</sub> =R <sub>g</sub> · 2kΩ	V <sub>OUT</sub>	—	—	-43	dBm

Electrical Characteristics Test Circuit

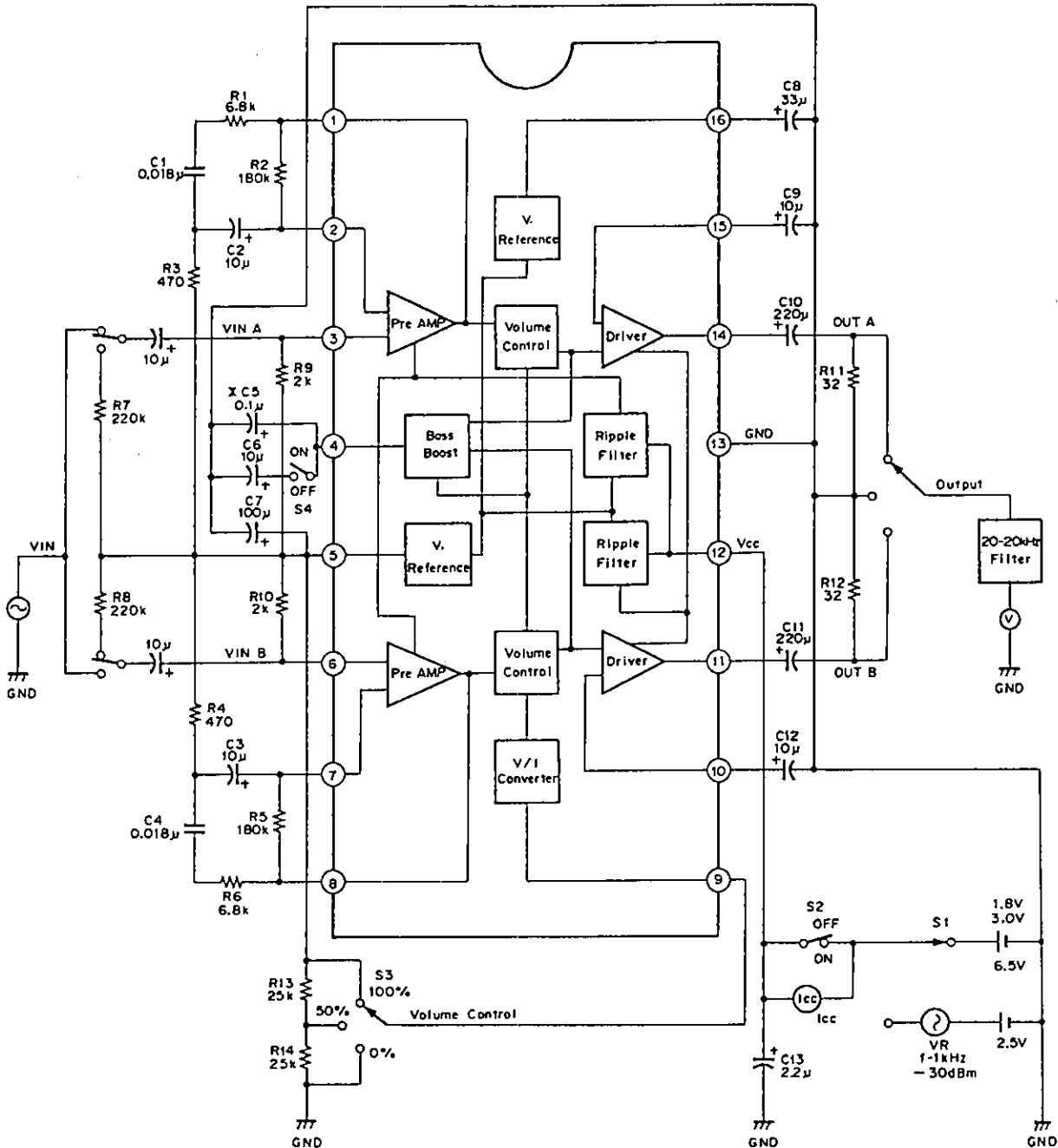

\* The external capacitance C5 of Pin 4 determines the time constant of bass boost function. An L.P.F. with cut-off is formed at 100Hz when C5 is 0.1 μF and at 1kHz when it is 0.01 μF.

Application Circuit

Pocketable stereo cassette player

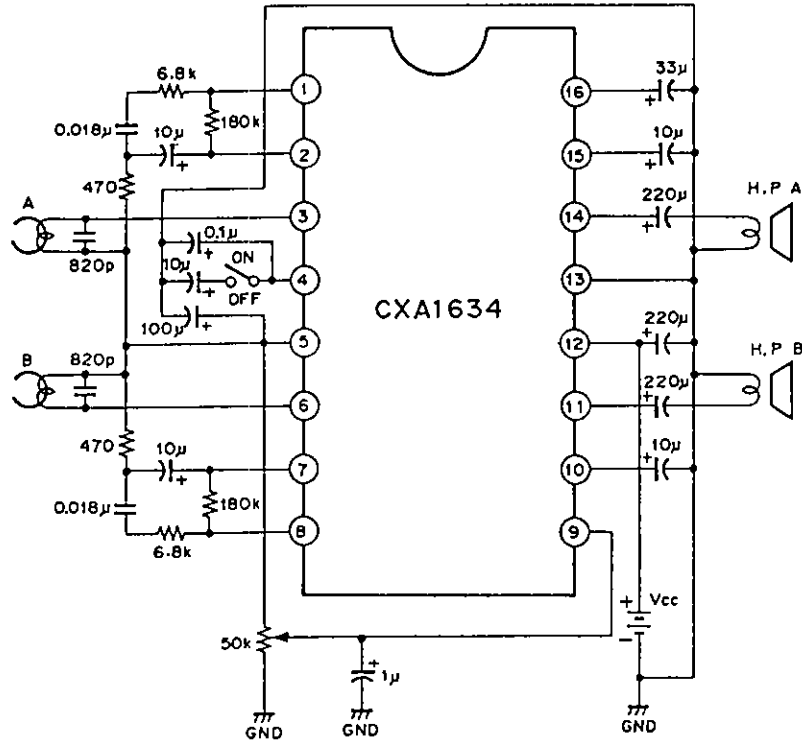

Pocketable stereo cassette player with radio

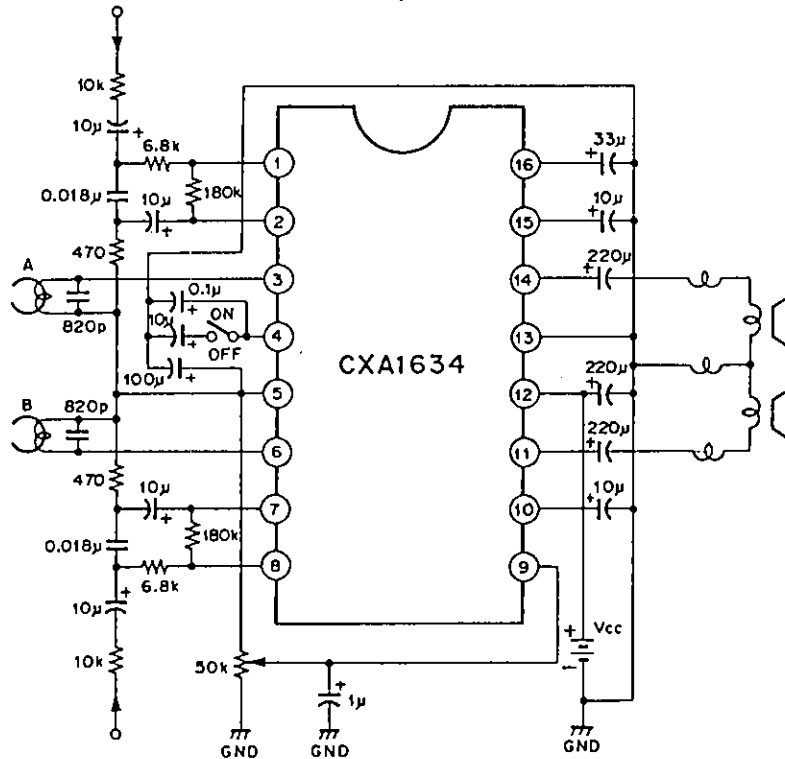

Application circuits shown are typical examples illustrating the operation of the devices. Sony cannot assume responsibility for any problems arising out of the use of these circuits or for any infringement of third party patent and other right due to same.

Description of Operation

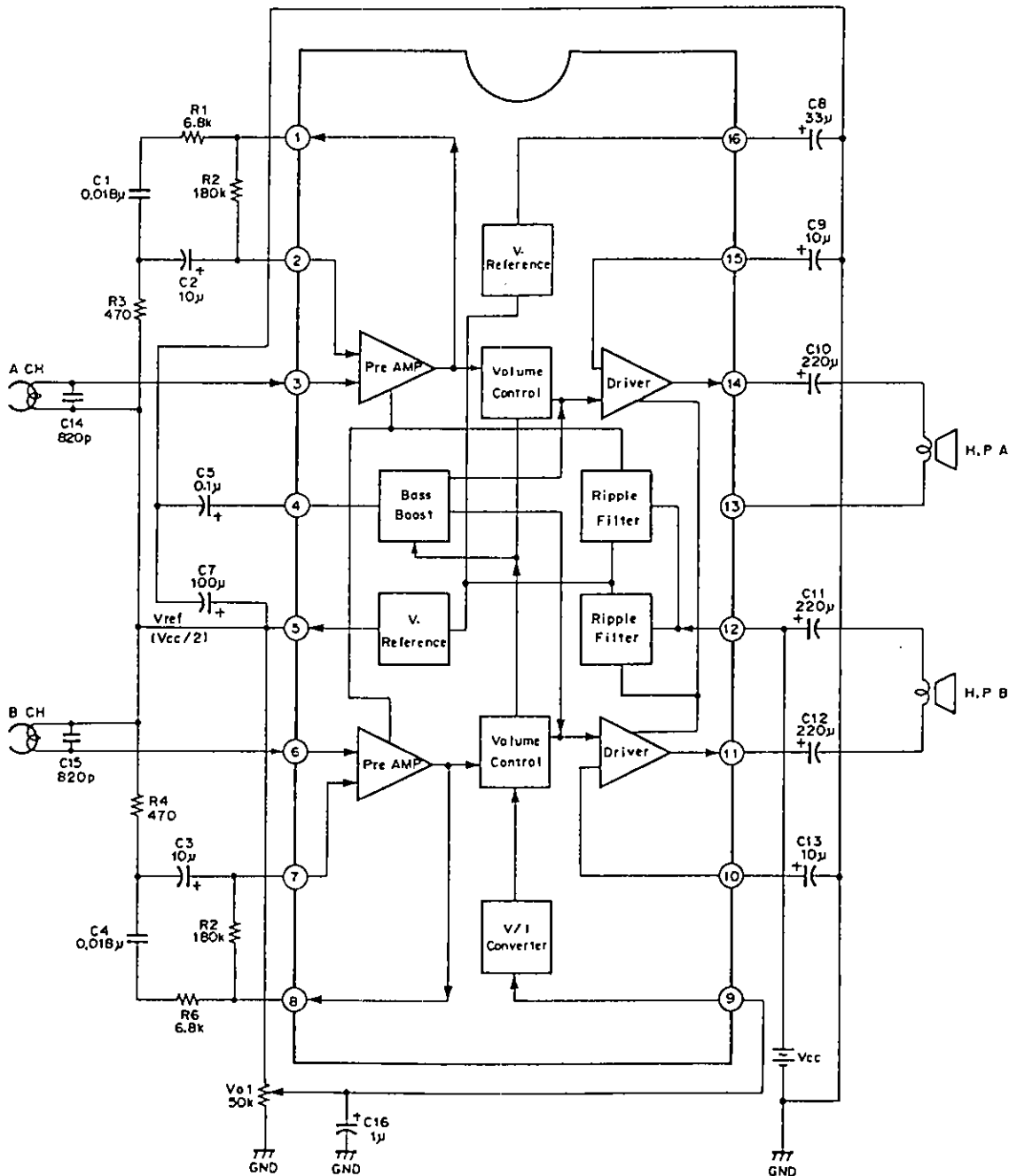

The signal from the playback head is input from Pins 3 and 6 (input) to obtain approximately 30dB (1kHz) signal amplification at the pre-amplifier stage and NAB equivalent characteristic through the low frequency correction circuit. The DC control voltage from Pin 9 is converted to current and control the volume control circuit. The low frequency component is amplified by approximately 7dB (50Hz) through the bass boost circuit according to the time constant determined by Pin 4. The headphone driver circuit provides approximately 30dB signal amplification and sufficient driving power.

Pin 5 ( $V_{REF}$ ) is floating at approximately  $V_{CC}/2$  to provide a wide operating range (1.8 to 6.5V). C16 is for absorbing volume sliding noise.



Example of Representative Characteristics

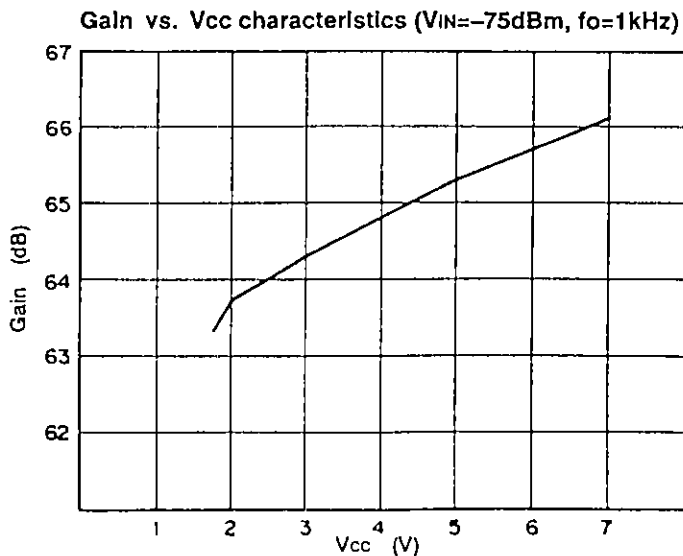
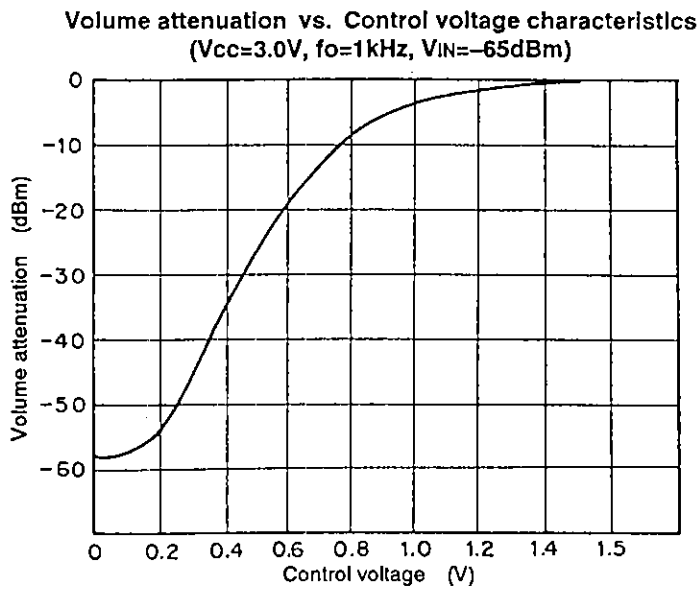
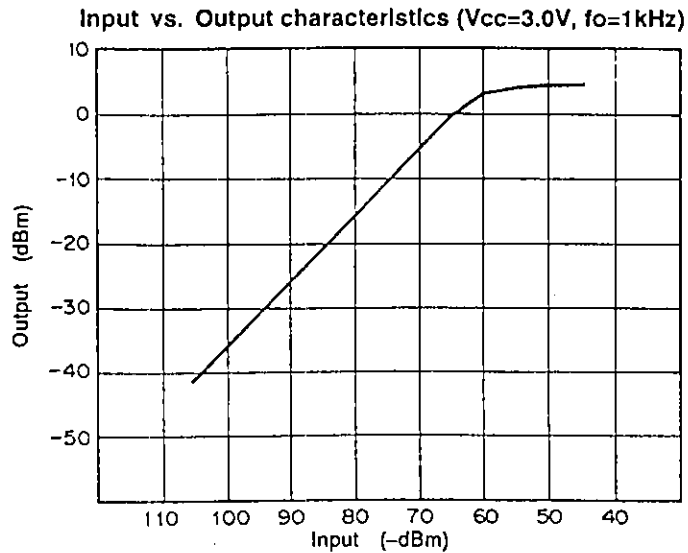

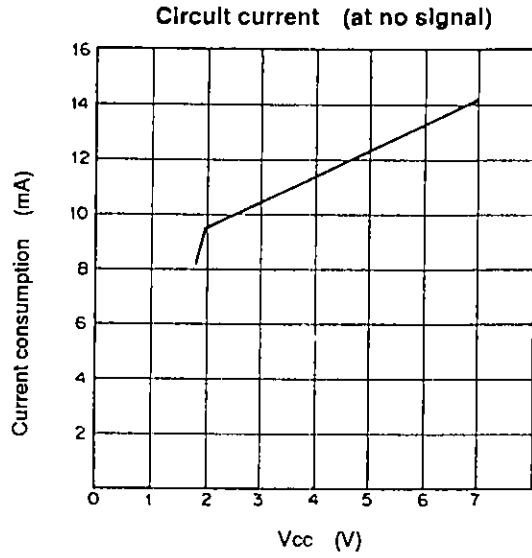

**Maximum output vs. Vcc characteristics (32Ω load)**  
(fo=1kHz, THD=10%, RL=32Ω)

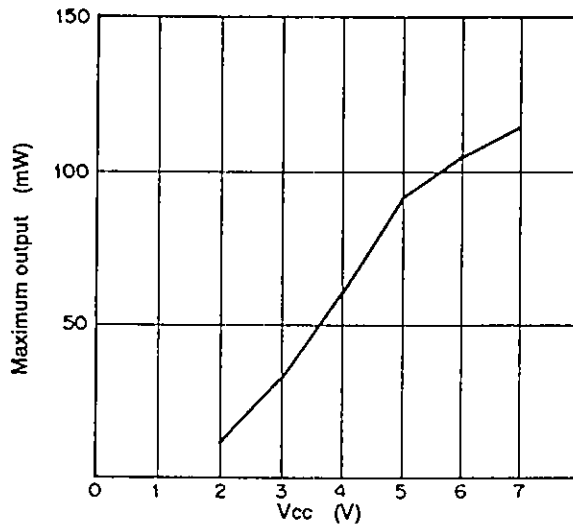

**Maximum output vs. Vcc characteristics (8Ω load)**  
(fo=1kHz, THD=10%, RL=8Ω)

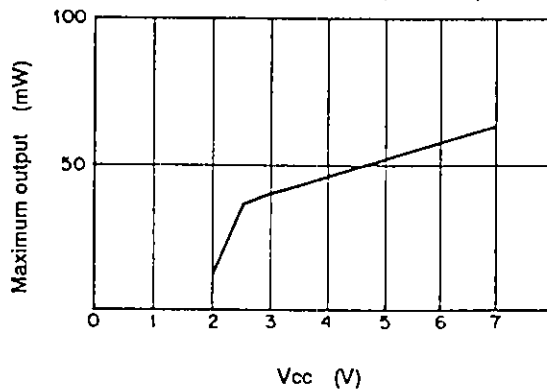

Distortion factor vs. Input characteristics

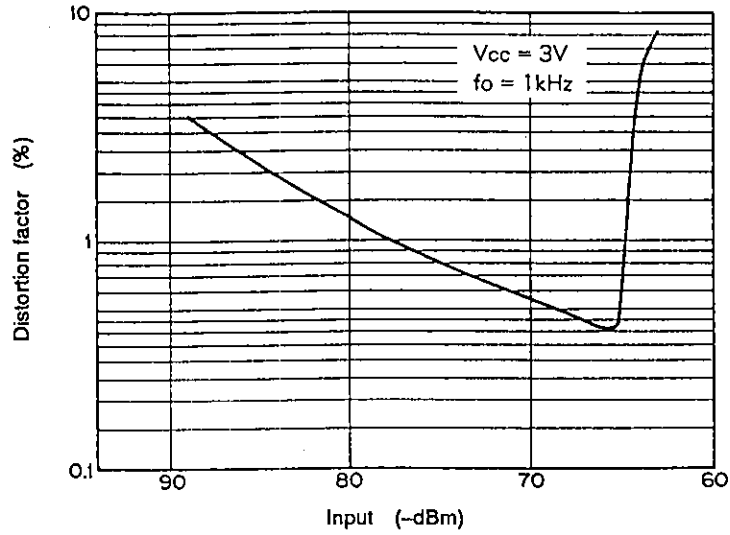

Frequency characteristics

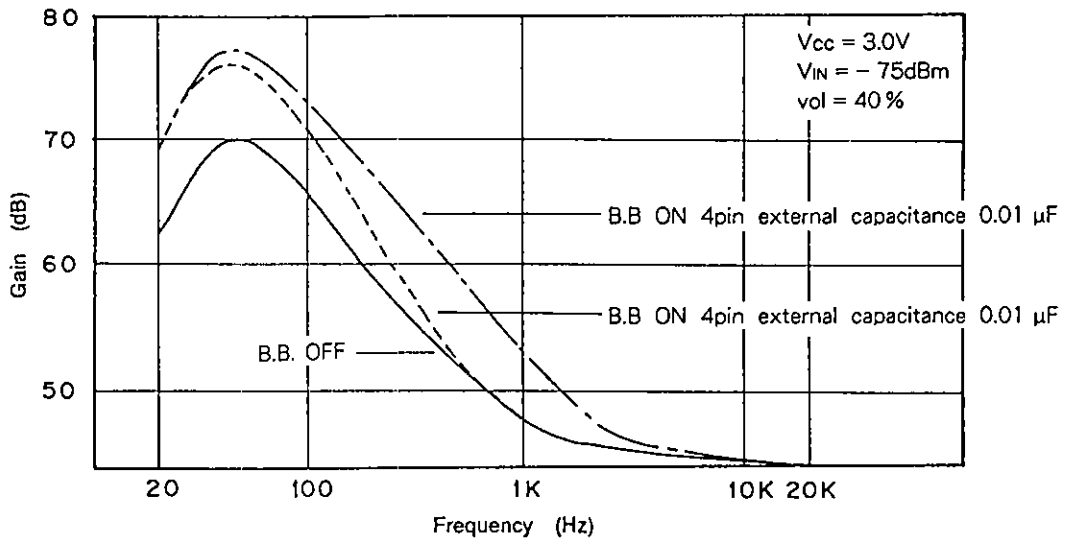

Inter-channel cross talk vs. Frequency characteristics

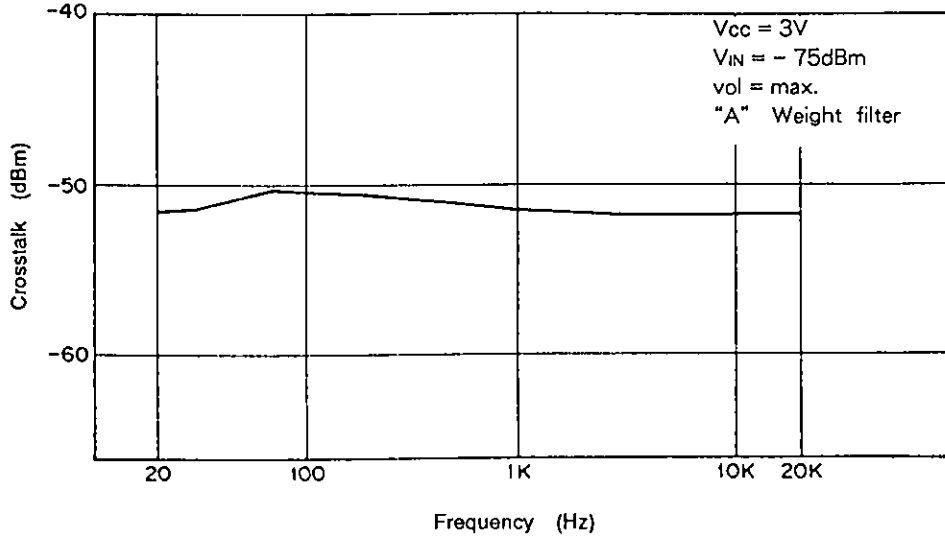

Package Outline Unit : mm

CXA1634P 16pin DIP (Plastic) 300mil 1.0g

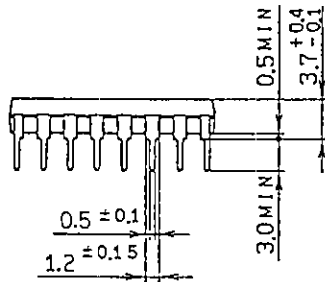
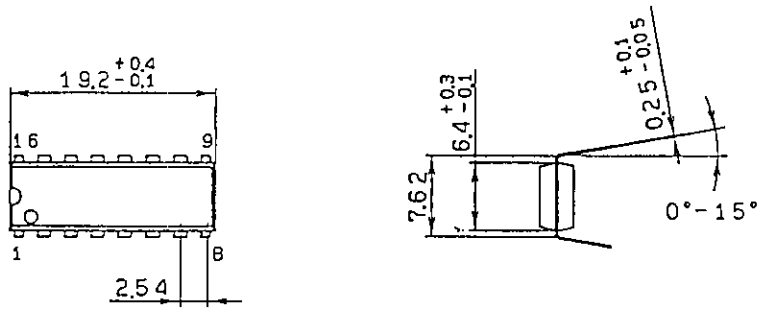

SONY NAME	DIP-16P-01
EIAJ NAME	*DIP016-P-0300-A
JEDEC CODE	MO-001-AE *

\* (Similar)

CXA1634M 16pin SOP (Plastic) 300mil 0.2g

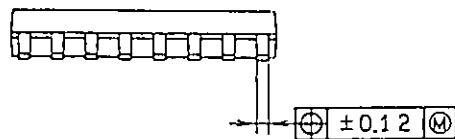
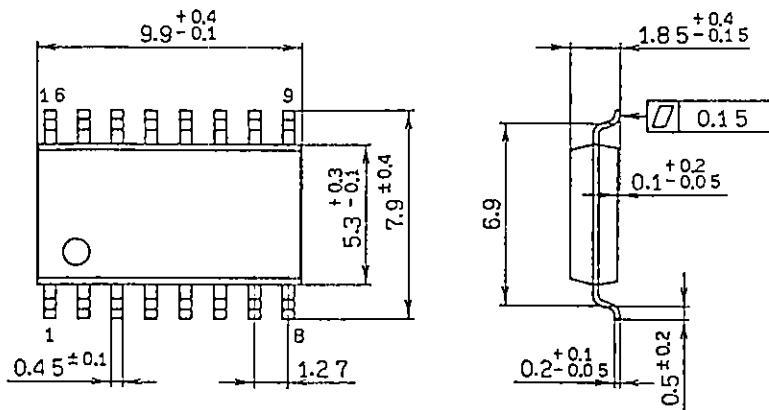

SONY NAME	SOP-16P-L01
EIAJ NAME	*SOP016-P-0300-A
JEDEC CODE	_____