

SONY

CXA1673M/P

2 Channel Surround

Description

CXA1673M/P is a surround effect and bass boost IC designed for radio cassette, clock radio, car stereo and TV sets.

Feature

- Surround level control
- In response to signal level
- Small number of peripheral components
- Wide range of power supply voltage

Absolute Maximum Ratings (Ta=25°C)

• Supply voltage	Vcc	12	V
• Operating temperature	Topr	-20 to +75	°C
• Storage temperature	Tstg	-65 to +150	°C
• Allowable power dissipation			
	Pd	DIP	900 mW
		SOP	500 mW

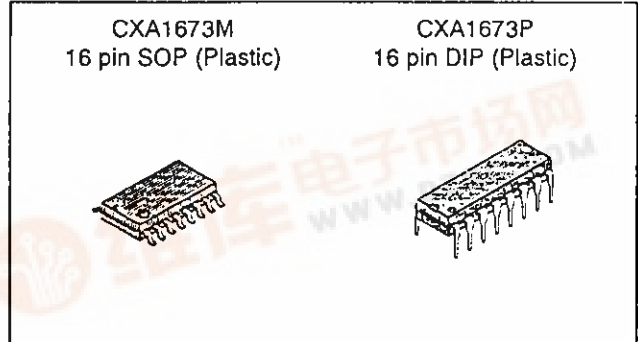

Application

Radio cassette, Car stereo, TV

Structure

Bipolar silicon monolithic IC

Operating Condition

Supply voltage	Vcc	1.8 to 10.0	V
----------------	-----	-------------	---

Block Diagram and Pin Configuration

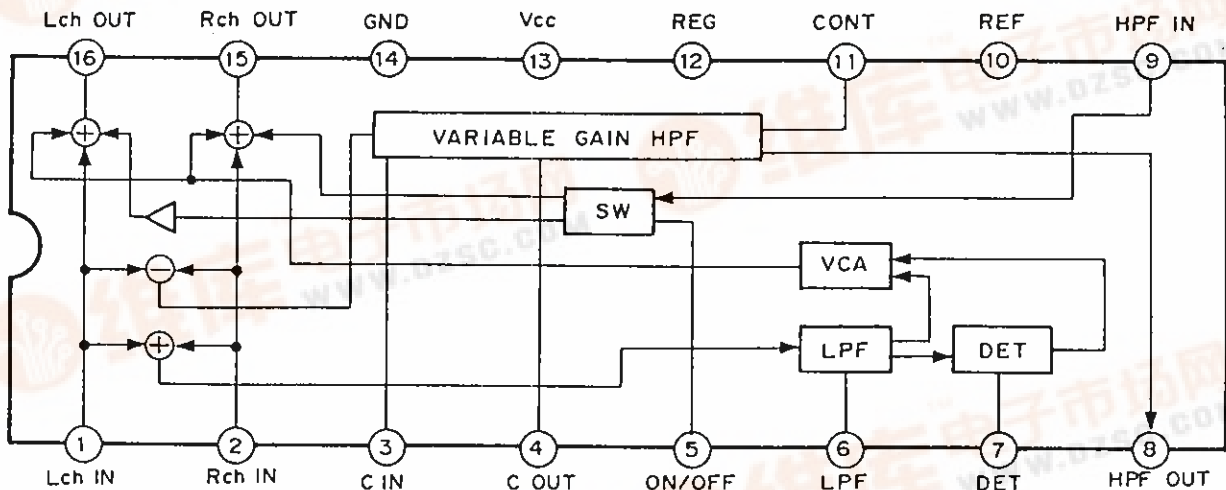

Sony reserves the right to change products and specifications without prior notice. This information does not convey any license by any implication or otherwise under any patents or other right. Application circuits shown, if any, are typical examples illustrating the operation of the devices. Sony cannot assume responsibility for any problems arising out of the use of these circuits.



Pin Description

(Vcc=6V, Ta=25°C)

No.	Symbol	Pin voltage	Equivalent Circuit	Description
1 2	L IN R IN	3V		Channel L input pin Channel R input pin
3	C IN	3V		The pin to be connected with a capacitor for variable gain H.P.F.
4	C OUT	3V		The pin to be connected with a capacitor for variable gain H.P.F.
5	SW	—		Surround effect ON/OFF

No.	Symbol	Pin voltage	Equivalent Circuit	Description
6	LPF	3V		Time constants for L.P.F. (bass boost)
7	DET	3V		Low frequency level detector
8	OUT	3V		H.P.F. output pin
9	IN	3V		Surround signal input pin

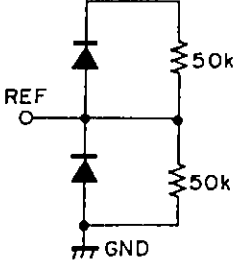
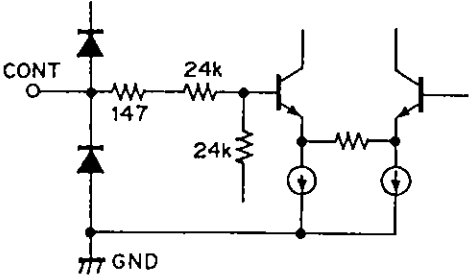
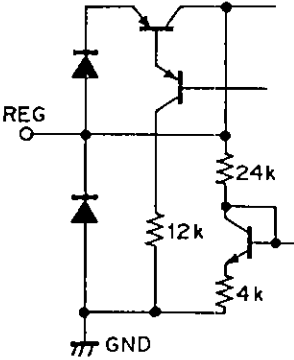
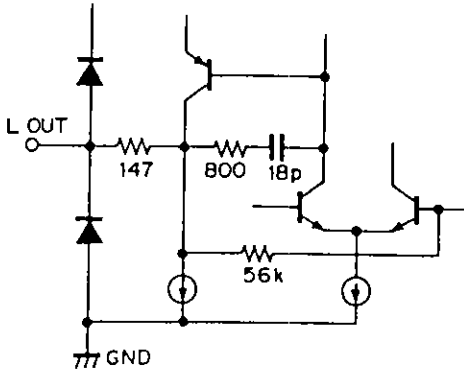
No.	Symbol	Pin voltage	Equivalent Circuit	Description
10	REF	3V		Reference voltage (1/2 Vcc)
11	CONT	—		H.P.F. gain control
12	REG	1.25V		Filter of power supply
13	Vcc	6V		Power supply
14	GND	0V		GND pin
15 16	R OUT L OUT	3V		Channel R output pin Channel L output pin

Electrical Characteristics

(Vcc=6V, Ta=25 °C)

Item	Condition	SW condition						Min.	Typ.	Max.	Unit
		S1	S2	S3	S4	S5	S6				
No signal current	No signal (VIN=GND)					○		—	4	6	mA
Lch voltage gain	VIN=-20dBm, f=1kHz					○		-3	0	3	dB
Rch voltage gain	VIN=-20dBm, f=1kHz	○				○	○	-3	0	3	dB
Channel Balance	Lch Voltage gain - Rch Voltage gain	—	—	—	—	—	—	-3	0	3	dB
Lch total harmonic distortion factor	VIN=-20dBm, f=1kHz					○		0.2	1	%	
Rch total harmonic distortion factor	VIN=-20dBm, f=1kHz	○				○	○	0.2	1	%	
Lch output noise level	No signal (VIN=GND)		○			○		-74	-66	dBm	
Rch output noise level	No signal (VIN=GND)		○			○	○	-74	-66	dBm	
Bass boost level	VIN=-60dBm, f=50Hz, Lch=Rch		○			○		11	19	27	dB
High boost level (Max.)	VIN=-20dBm, f=10kHz (CONT=GND)	○		○	○			3.5	6	8.5	dB
High boost level (Min.)	VIN=-20dBm, f=10kHz (CONT=REG)	○		○	○	○		-1	1	3	dB

○ ... ON

Electrical Characteristics Test Circuit

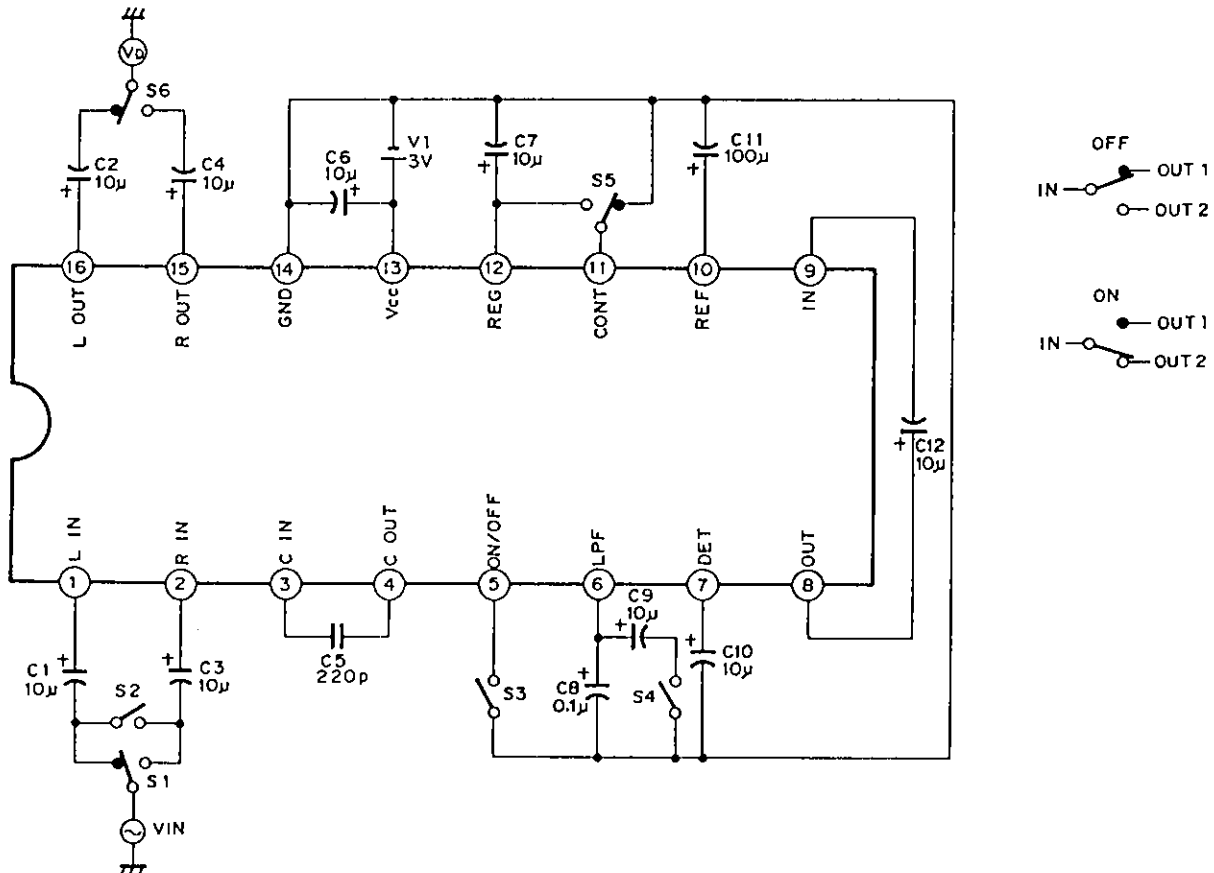

Application Circuit

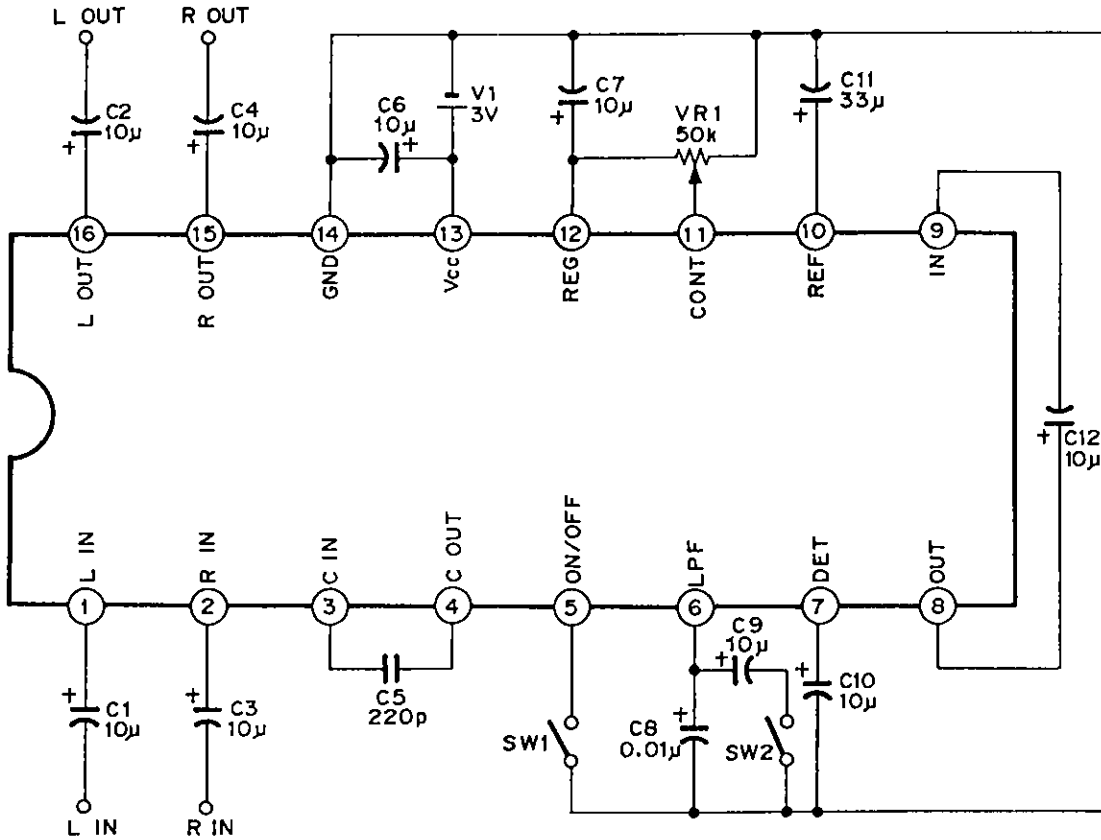

- SW1 : Surround ON/OFF
(Surround effect is turned ON when Pin 5 is connected to GND.)
- SW2 : Bass boost ON/OFF
(Bass boost function is turned OFF when SW2 is turned ON and the cut off frequency of the LPF is lowered.)
- VR1 : Surround effect control
Surround effect is variable by the voltage at Pin 11.
Surround effect is maximum when VR1 is connected to GND and minimum when VR1 is connected to REG.

Application circuits shown are typical examples illustrating the operation of the devices. Sony cannot assume responsibility for any problems arising out of the use of these circuits or for any infringement of third party patent and other right due to same.

**Bass boost vs. Frequency characteristics
(Connected with a Input level)**

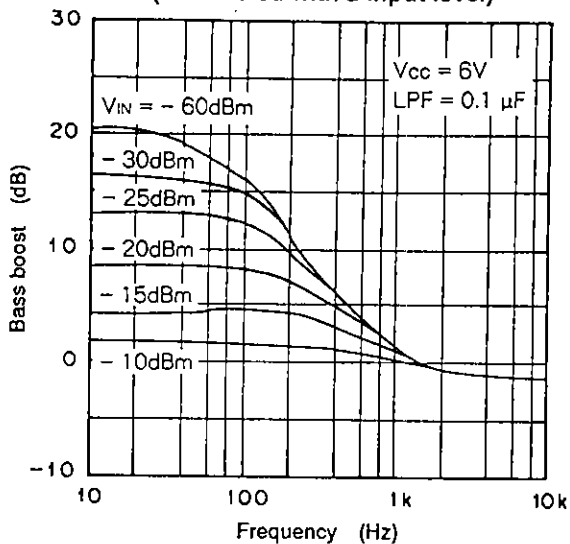

Surround effect vs. Frequency characteristics

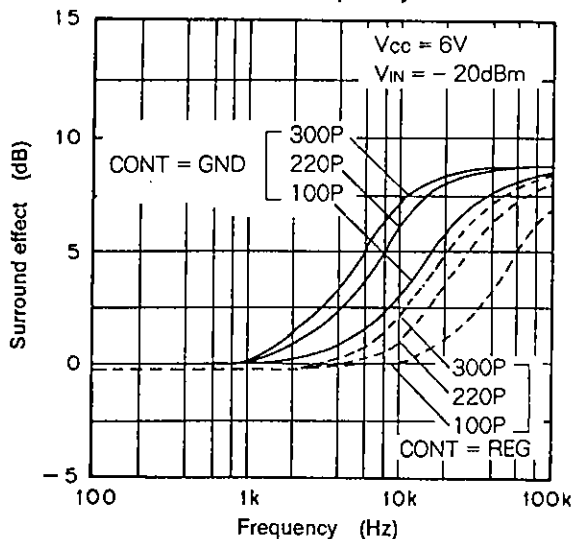

**Bass boost vs. Frequency characteristics
(Connected with a capacitor for L.P.F.)**

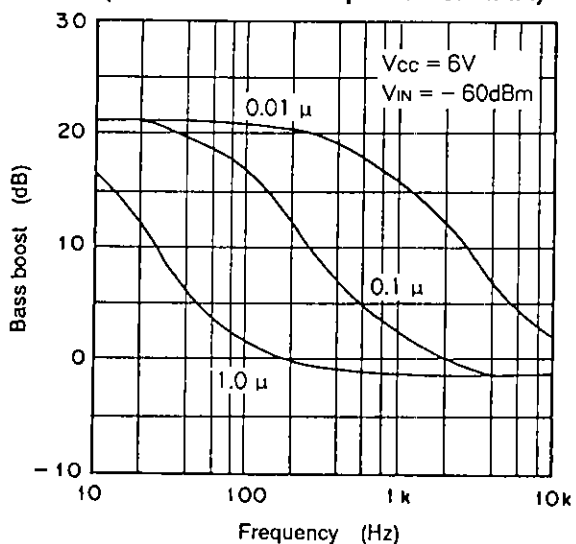

Vcc vs. Icc characteristics

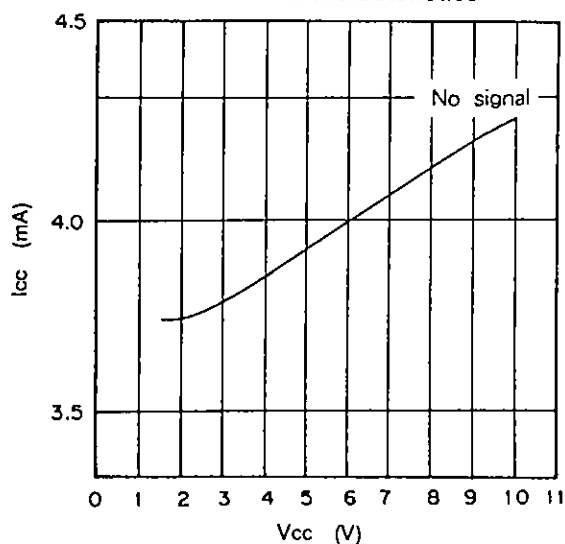

Package Outline Unit : mm

CXA1673M 16pin SOP (Plastic) 300mil 0.2g

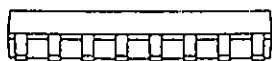
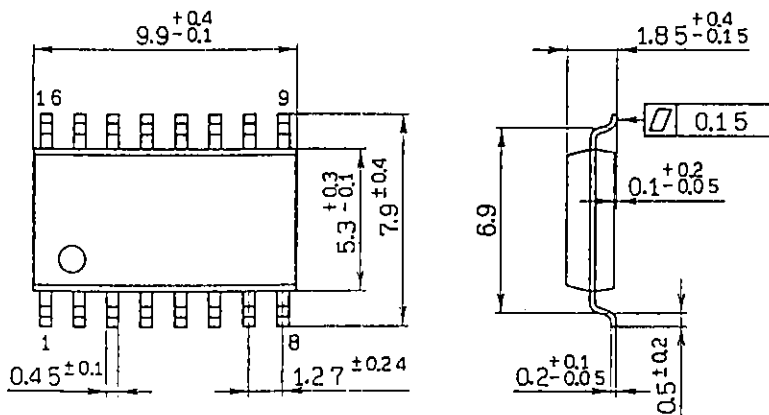

SONY NAME	SOP-16P-L01
EIAJ NAME	*SOP016-P-0300-A
JEDEC CODE	

CXA1673P 16pin DIP (Plastic) 300mil 1.0g

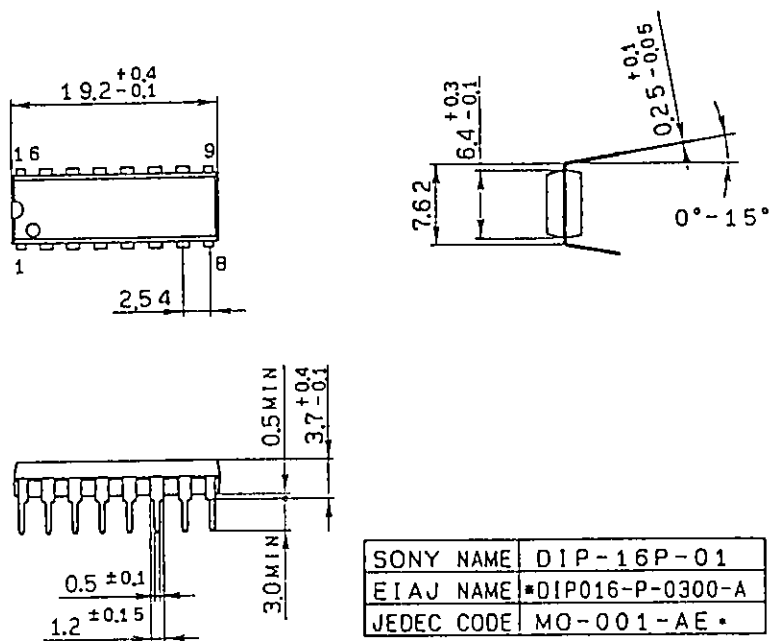

SONY NAME	DIP-16P-01
EIAJ NAME	*DIP016-P-0300-A
JEDEC CODE	MO-001-AE*

* (Similar)