

**SONY**

**CXD2460R**

**Timing Generator for Progressive Scan CCD Image Sensor**

**Description**

The CXD2460R is an IC developed to generate the timing pulses required by Progressive Scan CCD image sensors as well as signal processing circuits.

**Features**

- Electronic shutter function
- Supports non-interlaced operation
- Base oscillation frequency 28.636MHz
- Horizontal drive frequency switchable between 14.3/7.2MHz
- Switchable between FINE (Progressive Scan) mode or DRAFT (high-speed draft) mode
- Built-in vertical driver

**Applications**

Progressive Scan CCD cameras

**Structure**

Silicon gate CMOS IC

**Applicable CCD Image Sensor**

ICX205AK

48 pin LQFP (Plastic)

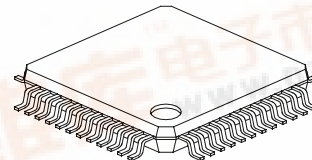

**Absolute Maximum Ratings**

- Supply voltage  $V_{DDA}, V_{DDb}, V_{DDc}, V_{DDd}$   
 $V_{SS} - 0.5$  to  $V_{SS} + 7.0$  V
- Supply voltage  $V_{SS}$   $V_L - 0.5$  to  $V_L + 26.0$  V
- Supply voltage  $V_H$   $V_L - 0.5$  to  $V_L + 26.0$  V
- Supply voltage  $V_M$   $V_L - 0.5$  to  $V_L + 26.0$  V
- Input voltage  $V_i$   $V_{SS} - 0.5$  to  $V_{DDA,b,c,d} + 0.5$  V
- Output voltage  $V_o$   $V_{SS} - 0.5$  to  $V_{DDA,b,c,d} + 0.5$  V
- Operating temperature  
 $T_{opr}$   $-20$  to  $+75$  °C
- Storage temperature  
 $T_{stg}$   $-55$  to  $+150$  °C

**Recommended Operating Conditions**

- Supply voltage 1  $V_{DDA}, V_{DDb}, V_{DDd}$   
3.0 to 3.6 V
- Supply voltage 2  $V_{DDc}$  3.0 to 5.25 V
- Supply voltage 3  $V_H$  14.25 to 15.75 V
- Supply voltage 4  $V_L$   $-9.0$  to  $-5.0$  V
- Supply voltage 5  $V_M$  0 V
- Operating temperature  
 $T_{opr}$   $-20$  to  $+75$  °C

Sony reserves the right to change products and specifications without prior notice. This information does not convey any license by any implication or otherwise under any patents or other right. Application circuits shown, if any, are typical examples illustrating the operation of the devices. Sony cannot assume responsibility for any problems arising out of the use of these circuits.



Block Diagram

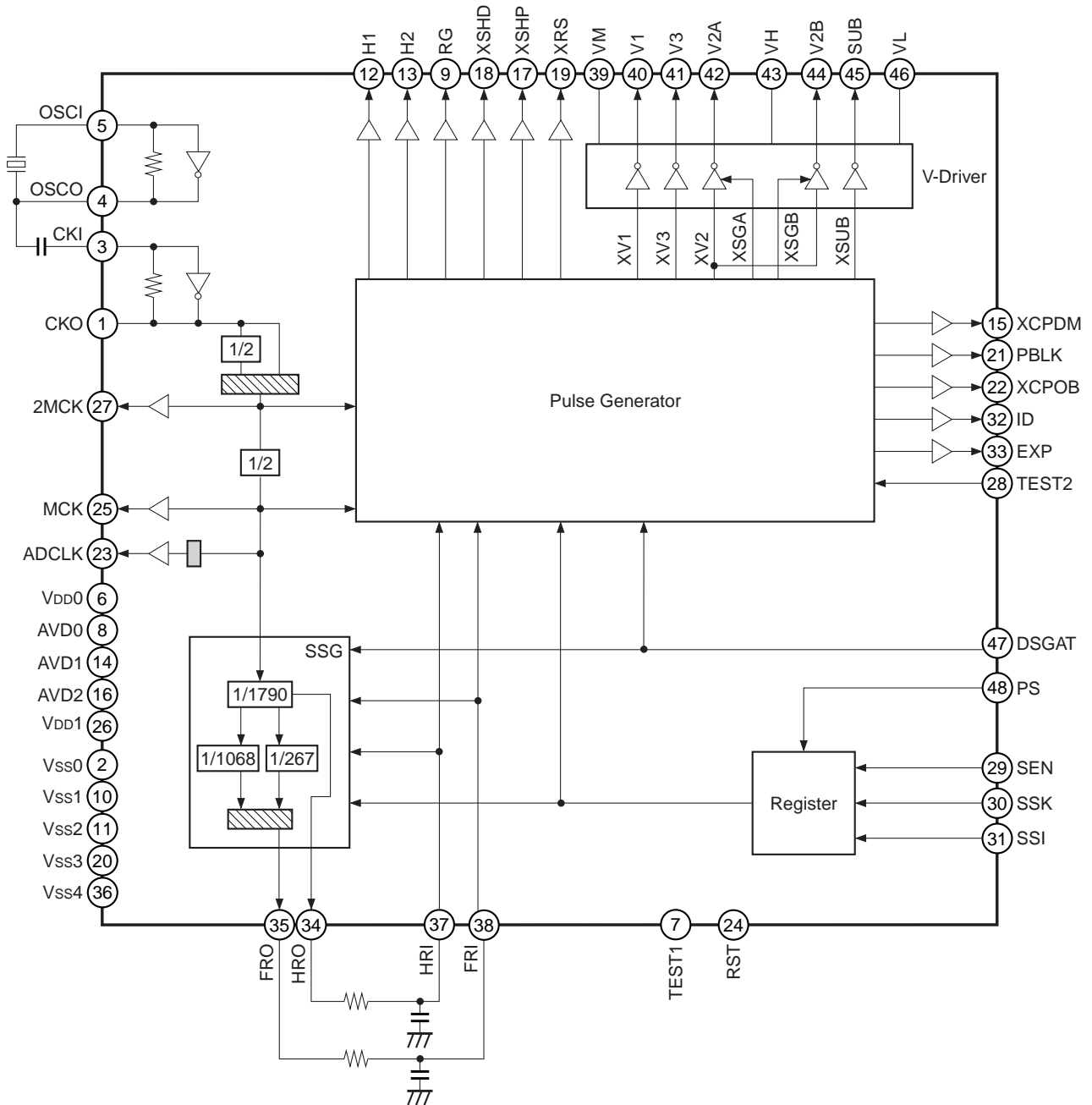

XSGA and XSGB are readout pulses that use V2A and V2B, respectively, as the VH value.

Pin Configuration (Top View)

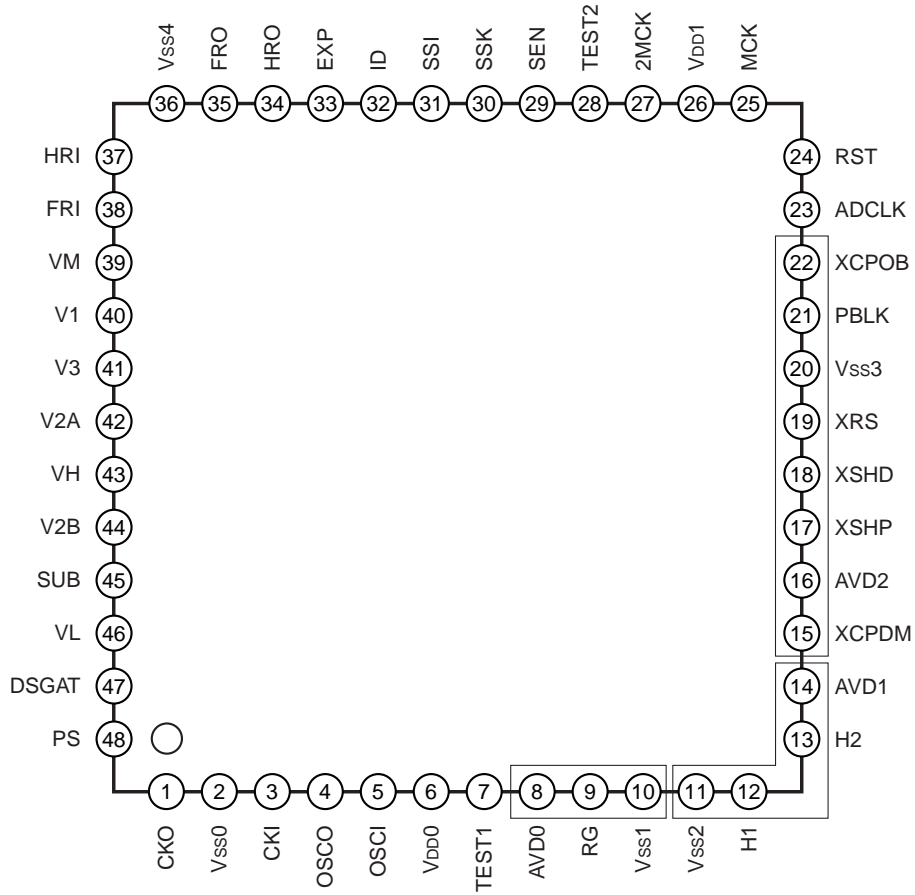

The enclosed pins use separate power supplies.

## Pin Description

Pin No.	Symbol	I/O	Description
1	CKO	O	Oscillator output. (28.6MHz)
2	Vss0	—	GND
3	CKI	I	Oscillator input. (28.6MHz)
4	OSCO	O	Inverter output for oscillation. (28.6MHz)
5	OSCI	I	Inverter input for oscillation. (28.6MHz)
6	V <sub>DD0</sub>	—	Power supply.
7	TEST1	I	Test. With pull-down resistor. Fix to low.
8	AVD0	—	Power supply.
9	RG	O	Reset gate pulse output.
10	Vss1	—	GND
11	Vss2	—	GND
12	H1	O	Clock output for horizontal CCD drive.
13	H2	O	Clock output for horizontal CCD drive.
14	AVD1	—	Power supply.
15	XCPDM	O	Clamp pulse.
16	AVD2	—	Power supply.
17	XSHP	O	Sample-and-hold pulse.
18	XSHD	O	Sample-and-hold pulse.
19	XRS	O	Sample-and-hold pulse.
20	Vss3	—	GND
21	PBLK	O	Blanking cleaning pulse.
22	XCPOB	O	Clamp pulse.
23	ADCLK	O	Clock output for AD conversion.
24	RST	I	Reset (Low: Reset, High: Normal operation). Always input one reset pulse during power-on.
25	MCK	O	Clock output for digital circuit.
26	V <sub>DD1</sub>	—	Power supply.
27	2MCK	O	Clock output for digital circuit.
28	TEST2	I	Test. Fix to high.
29	SEN	I	PS = High: Drive frequency setting input. PS = Low: Serial setting strobe input.
30	SSK	I	PS = High: Readout method setting input. PS = Low: Serial setting clock input.
31	SSI	I	PS = High: Shutter speed setting input. PS = Low: Serial setting data input.
32	ID	O	Line identification signal output write enable pulse output or XSUB output.
33	EXP	O	Pulse output indicating exposure is underway or checksum result output.

Pin No.	Symbol	I/O	Description
34	HRO	O	Horizontal sync signal (HR) output or XSGA output.
35	FRO	O	Vertical sync signal (FR) output or XSGB output.
36	Vss4	—	GND
37	HRI	I	Horizontal sync signal (HR) input.
38	FRI	I	Vertical sync signal (FR) input.
39	VM	—	GND (vertical clock driver GND).
40	V1	O	Clock output for vertical CCD drive.
41	V3	O	Clock output for vertical CCD drive.
42	V2A	O	Clock output for vertical CCD drive.
43	VH	—	15V power supply (vertical clock driver power supply).
44	V2B	O	Clock output for vertical CCD drive.
45	SUB	O	CCD electric charge sweep pulse output.
46	VL	—	−8.0V power supply (vertical clock driver power supply).
47	DSGAT	I	Output stop (Same operation control as SLP when low).
48	PS	I	Parallel/serial switching for mode setting input method. (High: Parallel, Low: Serial) With pull-down resistor.

Electrical Characteristics

DC Characteristics

(Within the recommended operating conditions)

Item	Pins	Symbol	Conditions	Min.	Typ.	Max.	Unit
Supply voltage 1	V <sub>DD0</sub> , V <sub>DD1</sub> ,	V <sub>DDa</sub>		3.0	3.3	3.6	V
Supply voltage 2	AVD0	V <sub>DDb</sub>		3.0	3.3	3.6	V
Supply voltage 3	AVD1	V <sub>DDc</sub>		3.0	5.0	5.25	V
Supply voltage 4	AVD2	V <sub>DDd</sub>		3.0	3.3	3.6	V
Supply voltage 5	VH	VH		14.5	15.0	15.5	V
Supply voltage 6	VM	VM		—	0.0	—	V
Supply voltage 7	VL	VL		−9.0		−5.0	V
Input voltage 1	CKI	V <sub>IH1</sub>		0.7V <sub>DDa</sub>			V
		V <sub>IL1</sub>				0.3V <sub>DDa</sub>	V
Input voltage 2	TEST1, PS	V <sub>IH2</sub>		0.7V <sub>DDa</sub>			V
		V <sub>IL2</sub>				0.3V <sub>DDa</sub>	V
Input voltage 3	RST, TEST2, SEN, SSK, SSI, HRI, FRI, DSGAT	V <sub>t+1</sub>		0.8V <sub>DDa</sub>			V
		V <sub>t−1</sub>				0.2V <sub>DDa</sub>	V
Output voltage 1	CKO, MCK, 2MCK	V <sub>OH1</sub>	Feed current where I <sub>OH</sub> = −10.0mA	V <sub>DDa</sub> − 0.8			V
		V <sub>OL1</sub>	Pull-in current where I <sub>OL</sub> = 7.2mA			0.4	V
Output voltage 2	RG	V <sub>OH2</sub>	Feed current where I <sub>OH</sub> = −3.3mA	V <sub>DDb</sub> − 0.8			V
		V <sub>OL2</sub>	Pull-in current where I <sub>OL</sub> = 2.4mA			0.4	V
Output voltage 3	H1, H2	V <sub>OH3</sub>	Feed current where I <sub>OH</sub> = −36.0mA	V <sub>DDc</sub> − 0.8			V
		V <sub>OL3</sub>	Pull-in current where I <sub>OL</sub> = 24.0mA			0.4	V
Output voltage 4	XCPDM, XSHP, XSHD, XRS, PBLK, XCPOB	V <sub>OH4</sub>	Feed current where I <sub>OH</sub> = −3.3mA	V <sub>DDd</sub> − 0.8			V
		V <sub>OL4</sub>	Pull-in current where I <sub>OL</sub> = 2.4mA			0.4	V
Output voltage 5	ID, EXP, HRO, FRO	V <sub>OH5</sub>	Feed current where I <sub>OH</sub> = −2.4mA	V <sub>DDa</sub> − 0.8			V
		V <sub>OL5</sub>	Pull-in current where I <sub>OL</sub> = 4.8mA			0.4	V
Output voltage 6	SUB	V <sub>OH6</sub>	Feed current where I <sub>OH</sub> = −4.0mA	VH − 0.25			V
		V <sub>OL6</sub>	Pull-in current where I <sub>OL</sub> = 5.4mA			VL + 0.25	V
Output voltage 7	V1, V3	V <sub>OM7</sub>	Feed current where I <sub>OH</sub> = −5.0mA	VM − 0.25			V
		V <sub>OL7</sub>	Pull-in current where I <sub>OL</sub> = 10.0mA			VL + 0.25	V
Output voltage 8	V2A, V2B	V <sub>OM101</sub>	Feed current where I <sub>OH</sub> = −7.2mA	VH − 0.25			V
		V <sub>OM102</sub>	Pull-in current where I <sub>OL</sub> = 5.0mA			VM + 0.25	V
		V <sub>OL8</sub>	Feed current where I <sub>OH</sub> = −5.0mA	VM − 0.25			V
		V <sub>OL8</sub>	Pull-in current where I <sub>OL</sub> = 10.0mA			VL + 0.25	V

**Inverter I/O Characteristics for Oscillation**

(Within the recommended operating conditions)

Item	Pins	Symbol	Conditions	Min.	Typ.	Max.	Unit
Logical V <sub>th</sub>	OSCI	LV <sub>th</sub>			V <sub>DDA</sub> /2		V
Input voltage	OSCI	V <sub>IH</sub>		0.7V <sub>DDA</sub>			V
		V <sub>IL</sub>				0.3V <sub>DDA</sub>	V
Output voltage	OSCO	V <sub>OH</sub>	Feed current where I <sub>OH</sub> = -6.0mA	V <sub>DDA</sub> /2			V
		V <sub>OL</sub>	Pull-in current where I <sub>OL</sub> = 6.0mA			V <sub>DDA</sub> /2	V
Feedback resistor	OSCI, OSCO	RFB	V <sub>IN</sub> = V <sub>DDA</sub> or V <sub>SS</sub>	500k	2M	5M	Ω
Oscillator frequency	OSCI, OSCO	f		20		50	MHz

**Base Oscillation Clock Input Characteristics**

(Within the recommended operating conditions)

Item	Pins	Symbol	Conditions	Min.	Typ.	Max.	Unit
Logical V <sub>th</sub>	CKI	LV <sub>th</sub>			V <sub>DDA</sub> /2		V
Input voltage		V <sub>IH</sub>		0.7V <sub>DDA</sub>			V
		V <sub>IL</sub>				0.3V <sub>DDA</sub>	V
Input amplitude		V <sub>IN</sub>	f <sub>max</sub> 50MHz sine wave	0.3			V <sub>p-p</sub>

\*1 Input voltage is the input voltage characteristics for direct input from an external source. Input amplitude is the input amplitude characteristics for input through capacitor.

**Switching Characteristics**(V<sub>H</sub> = 15.0V, V<sub>M</sub> = GND, V<sub>L</sub> = -8.5V)

Item	Symbol	Conditions	Min.	Typ.	Max.	Unit
Rise time	TTLM	V <sub>L</sub> to V <sub>M</sub>		350	550	ns
	TTMH	V <sub>M</sub> to V <sub>H</sub>		450	700	ns
	TTLH	V <sub>L</sub> to V <sub>H</sub>		50	80	ns
Fall time	TTML	V <sub>M</sub> to V <sub>L</sub>		250	400	ns
	TTHM	V <sub>H</sub> to V <sub>M</sub>		300	450	ns
	TTHL	V <sub>H</sub> to V <sub>L</sub>		50	80	ns
Output noise voltage	VCLH				1.0	V
	VCLL				1.0	V
	VCMH				1.0	V
	VCML				1.0	V

\*1 The MOS structure of this IC has a low tolerance for static electricity, so full care should be given for measures to prevent electrostatic discharge.

\*2 For noise and latch-up countermeasures, be sure to connect a bypass capacitor (0.1μF or more) between each power supply pin (V<sub>H</sub>, V<sub>L</sub>) and GND.

Switching Waveforms

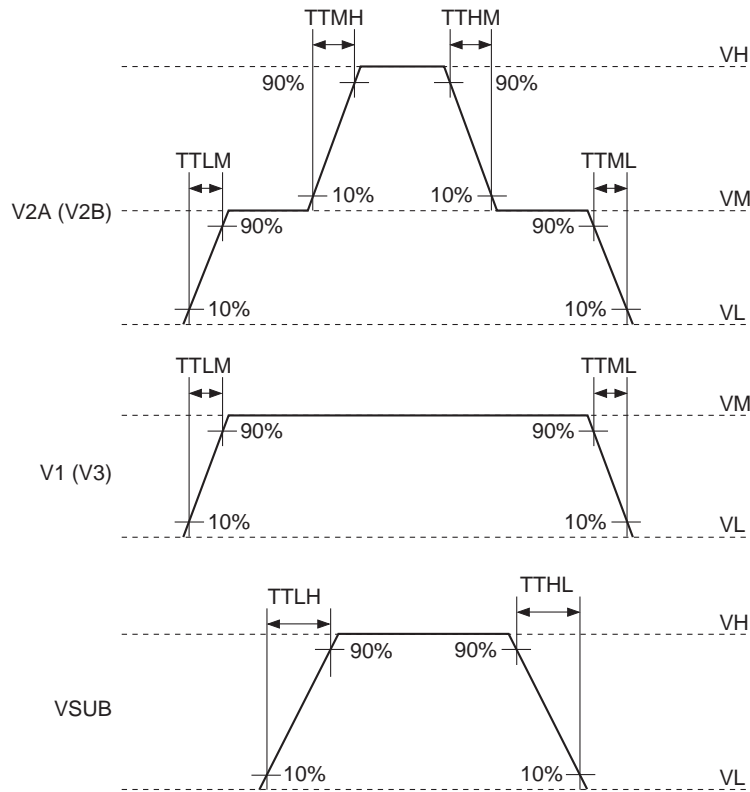

Waveform Noise

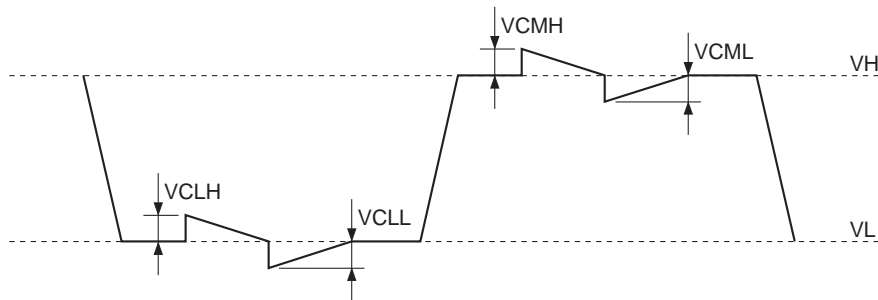

Measurement Circuit

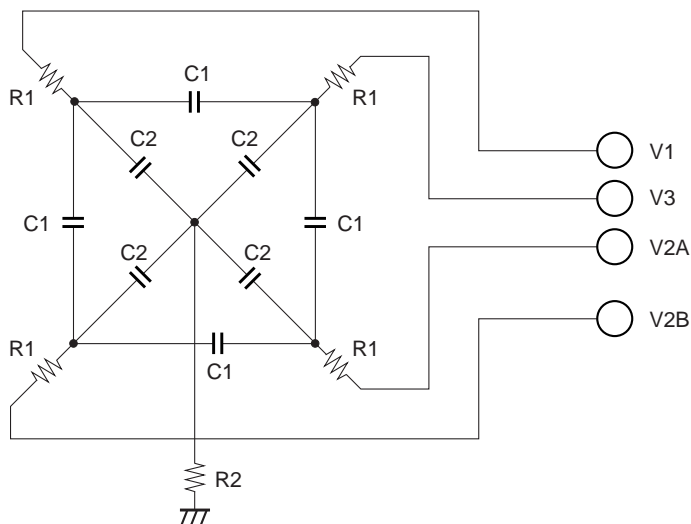

R1: 27Ω  
 R2: 5Ω  
 C1: 1500pF  
 C2: 3300pF



AC Characteristics

1) AC characteristics between the serial interface clocks

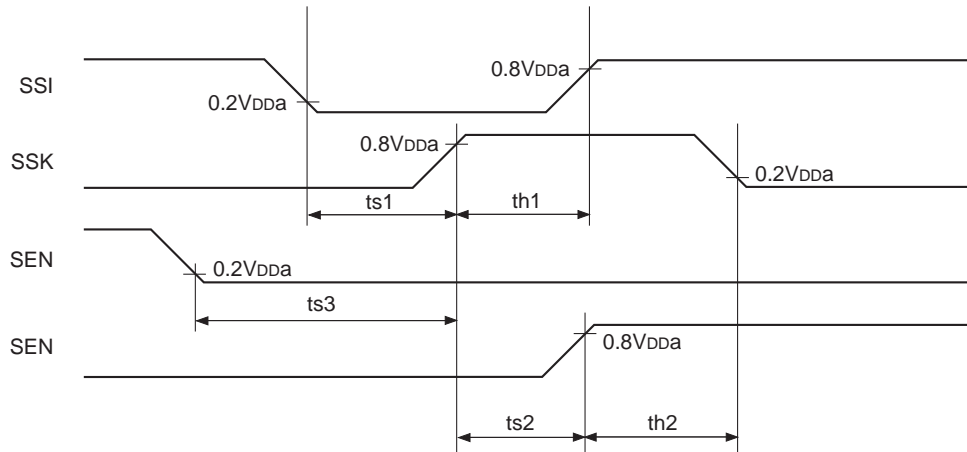

(Within the recommended operating conditions)

Symbol	Definition	Min.	Typ.	Max.	Unit
ts1	SSI setup time, activated by the rising edge of SSK	20			ns
th1	SSI hold time, activated by the rising edge of SSK	20			ns
ts2	SSK setup time, activated by the rising edge of SEN	20			ns
th2	SSK hold time, activated by the rising edge of SEN	20			ns
ts3	SEN setup time, activated by the rising edge of SSK	20			ns
fk	SSK frequency			7.15	MHz

2) Serial interface clock internal loading characteristics

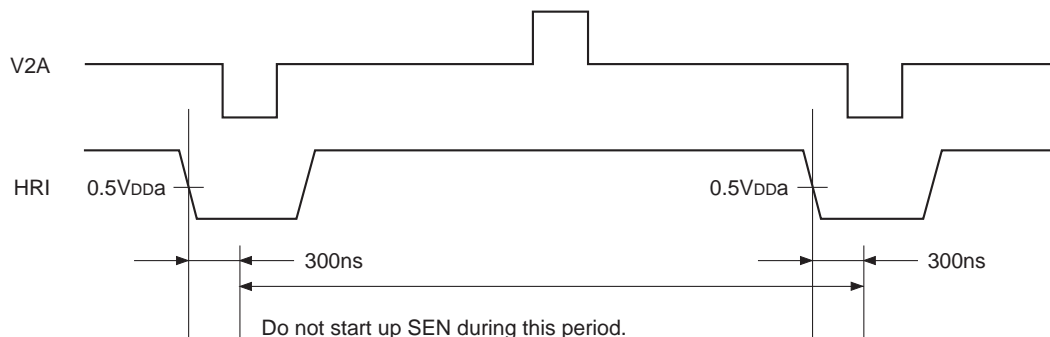

Do not start up SEN during this period.  
 (From 300ns from the falling edge of HRI immediately before generation of XSGA pulse to 300ns from the falling edge of HRI immediately after generation of XSGA pulse)

3) Output timing characteristics using DSGAT and RST

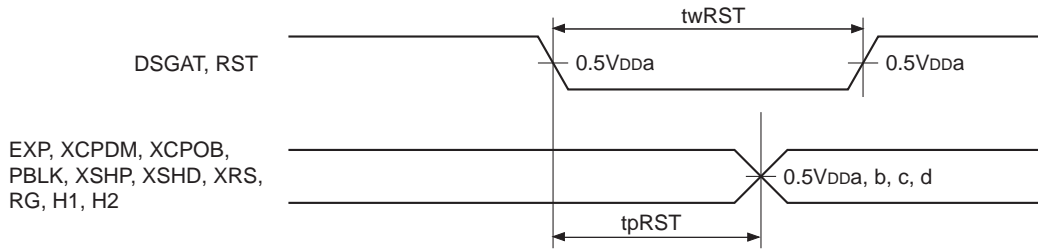

H1 and H2 load = 270pF

EXP, XCPDM, PBLK, XSHP, XSHD, XRS and RG load = 10pF (Within the recommended operating conditions)

Symbol	Definition	Min.	Typ.	Max.	Unit
tpRST	Time until the above outputs reach the specified value after the fall of DSGAT and RST			125	ns
twRST	RST and DSGAT pulse width	10			ns

4) FRI and HRI loading characteristics

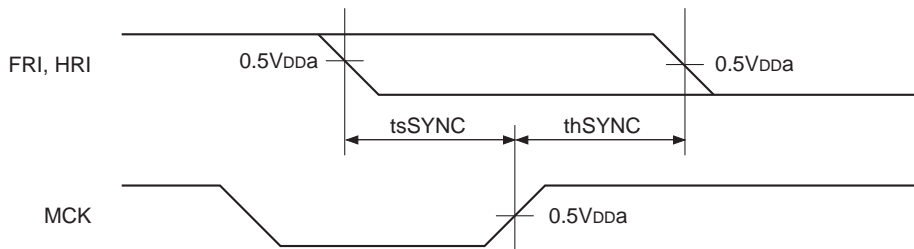

MCK load = 35pF

(Within the recommended operating conditions)

Symbol	Definition	Min.	Typ.	Max.	Unit
tsSYNC	FRI and HRI setup time, activated by the rising edge of MCK	5			ns
thSYNC	FRI and HRI hold time, activated by the rising edge of MCK	5			ns

5) Output variation characteristics of ID, WEN, EXP, FRO and HRO

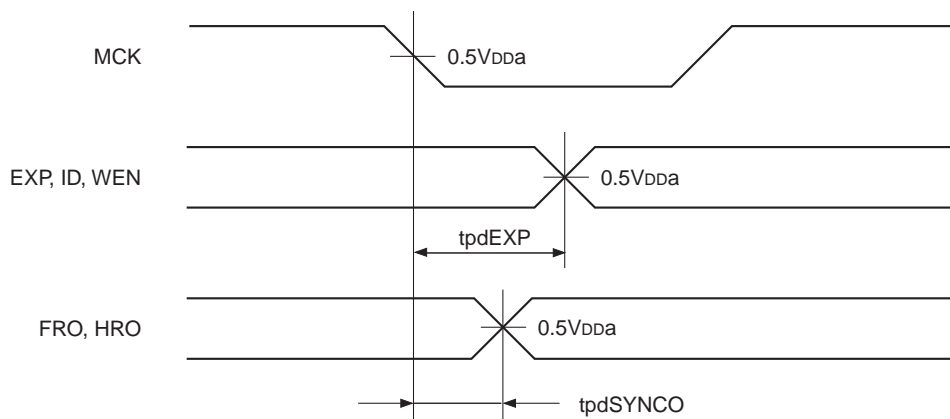

EXP, ID and WEN load = 10pF

(Within the recommended operating conditions)

Symbol	Definition	Min.	Typ.	Max.	Unit
t <sub>pdEXP</sub>	Time until the WEN, ID and EXP outputs change after the fall of MCK	0.5		8.5	ns
t <sub>pdSYNCO</sub>	Time until the FRO and HRO outputs change after the fall of MCK	0.5		3.5	ns

**Description of Operation**

**1. Progressive Scan CCD drive pulse generation**

- Combining this IC with a crystal oscillator generates a fundamental frequency of 28.636MHz.
- CCD drive pulse generation is synchronized with HRI and FRI.
- The CCD drive method can be changed to various modes by inputting serial data or parallel data to the CXD2460R.
- The various drive methods possessed by the CXD2460R are shown in the Timing Charts A-1 to 3 (V rate) and B-1 to 6 (H rate).

**2. Serial data input method**

- All CXD2460R operations can be controlled via the serial data. The serial data format is as follows.

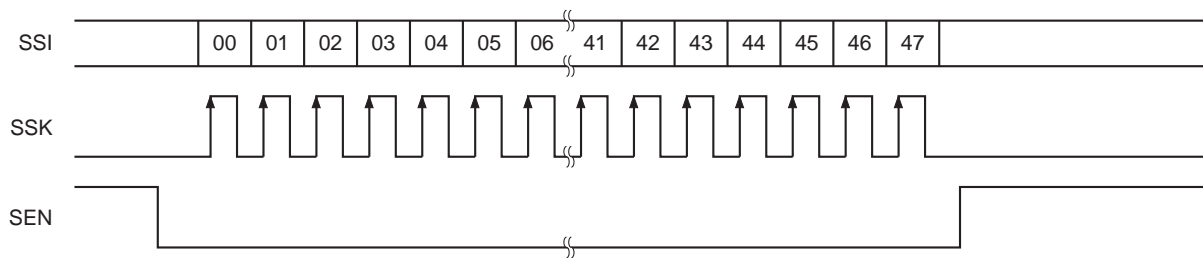

**Serial data format**

**Serial data**

Data	Symbol	Function		When reset
D00 to D07	CHIP	Chip switching	See D00 to D07 CHIP.	All 0
D08 to D11	CTGRY	Category switching	See D08 to D11 CTGRY.	All 0
D12 to D39	DATA	Control data for each category The meaning of this CTGRY control data differs according to the category set by D08 to D11.	See D12 to D39 DATA.	All 0
D40 to D47	Checksum bits	Checksum bits	See D40 to D47 CHKSUM.	All 0

3. Serial data and description of functions

		Detailed description							
<div style="border: 1px solid black; padding: 2px; display: inline-block;">D00</div> to <div style="border: 1px solid black; padding: 2px; display: inline-block;">D07</div> CHIP	The serial interface data is loaded to the CXD2460R when D00 and D07 are "1". However, this assumes that D40 to D47 CHKSUM is satisfied.								
	D07	D06	D05	D04	D03	D02	D01	D00	Function
	1	0	0	0	0	0	0	1	Loading to the CXD2460R
<div style="border: 1px solid black; padding: 2px; display: inline-block;">D08</div> to <div style="border: 1px solid black; padding: 2px; display: inline-block;">D11</div> CTGRY	This CTGRY data indicates the functions that the serial interface data controls.								
	D11	D10	D09	D08	Function				
	0	0	0	0	Mode control data				
	0	0	1	0	Electronic shutter control data				
	0	0	1	1	High-speed phase adjustment data (Set all of D12 to D39 to "0".)				
0	1	0	0	System setting data					
Input of values other than those listed above is prohibited.									

CTGRY: Mode control data

		Detailed description	
<div style="border: 1px solid black; padding: 2px; display: inline-block;">D12</div> FHIGH	0: Power saving drive mode 1: High-speed drive mode  When FHIGH = 0, the clock input to CKI is immediately frequency divided by 1/2 and loaded internally.		
<div style="border: 1px solid black; padding: 2px; display: inline-block;">D13</div> FINE	0: DRAFT mode 1: FINE mode  In FINE mode, image data is taken by the normal Progressive Scan method. In DRAFT mode, image data is taken by pulse elimination readout. This enables a frame rate four times that during FINE mode. The mode is switched at the fall of HRI just before XSGA. Note that the FRO output is also switched accordingly. (DRAFT mode: 267H, FINE mode: 1068H)		
	<div style="border: 1px solid black; padding: 2px; display: inline-block;">D14</div> NSG	0: Normal operation 1: Readout prohibited mode  In readout prohibited mode, a readout pulse is not added even at the timing when a readout pulse is added to V2A and V2B (VH value). (V1, V2 and V3 are not modulated.) The mode is normally switched at the fall of HRI just before the position where the readout pulse is added.	

Detailed description	
<p>D15 FS</p>	<p>0: Normal operation 1: FS mode</p> <p>In order to increase the frame rate, a certain portion of the captured image of CCD can be cut out by performing high-speed sweep.</p> <p>In FS mode, high-speed sweep is performed for the V registers of the entire image (period Z) after FRI input. Next, high-speed sweep is performed again for only the desired period (period X) after generating the XSGA/XSGB pulses. Then, after performing normal V transfer and outputting the effective signal (period Y), high-speed sweep is performed for the entire image again by inputting FRI at the desired timing. This makes it possible to take only the desired portion in the V direction, thus effectively increasing the frame rate.</p> <p>Operation is fixed during period Z, with 20 lines swept every 1H and repeating over a 69H period. During period X, first XSGA/XSGB are generated. These pulses are dependent on serial data FINE. In other words, if FINE = 1, then both XSGA and XSGB are generated, while if FINE = 0, only XSGA is generated. Next, sweep operation starts. This period is set in serial data FVFS (system setting data: D21 to D26) in HRI units. If FINE = 1, sweeping is performed at 8 lines per 1H, and if FINE = 0, sweeping is performed at 20 lines per 1H.</p> <p>The operations of V1, V2 and V3 after readout during period Y differ depending on the FINE data.</p> <div style="text-align: center;"> <p>• When the frame rate is increased as the vertical effective signal Y line (example)</p> <ul style="list-style-type: none"> <li><span style="display: inline-block; width: 15px; height: 10px; background-color: #cccccc; border: 1px solid black;"></span> Sweep variable period (period X)</li> <li><span style="display: inline-block; width: 15px; height: 10px; background: repeating-linear-gradient(45deg, transparent, transparent 2px, #cccccc 2px, #cccccc 4px); border: 1px solid black;"></span> Effective signal period (period Y)</li> <li><span style="display: inline-block; width: 15px; height: 10px; background: repeating-linear-gradient(-45deg, transparent, transparent 2px, #cccccc 2px, #cccccc 4px); border: 1px solid black;"></span> Sweep fixed period (period Z)</li> </ul> </div> <p>Timing chart</p> <p>Reset by FRI after normal transfer</p> <p>FRI</p> <p>Z X Y</p> <p>V2A</p> <p>69H (Fix) Set by FVFS</p>
<p>D16 to D17</p>	<p>Set to "0".</p>

Detailed description																																																																																																																																																																																																																																																																																																																								
Operation control settings																																																																																																																																																																																																																																																																																																																								
The operating mode control bits are loaded to the CXD2460R at the rise timing of the SEN input, and control is applied immediately.																																																																																																																																																																																																																																																																																																																								
<table border="1"> <thead> <tr> <th>D19</th> <th>D18</th> <th>Symbol</th> <th colspan="10">Control mode</th> </tr> </thead> <tbody> <tr> <td>0</td> <td>0</td> <td>CAM</td> <td colspan="10">Normal operation mode</td> </tr> <tr> <td>0</td> <td>1</td> <td>SLP</td> <td colspan="10">Sleep mode (mode for the status where CCD drive is not required)</td> </tr> <tr> <td>1</td> <td>X</td> <td>STN</td> <td colspan="10">Standby mode</td> </tr> </tbody> </table>													D19	D18	Symbol	Control mode										0	0	CAM	Normal operation mode										0	1	SLP	Sleep mode (mode for the status where CCD drive is not required)										1	X	STN	Standby mode																																																																																																																																																																																																																																																																	
D19	D18	Symbol	Control mode																																																																																																																																																																																																																																																																																																																					
0	0	CAM	Normal operation mode																																																																																																																																																																																																																																																																																																																					
0	1	SLP	Sleep mode (mode for the status where CCD drive is not required)																																																																																																																																																																																																																																																																																																																					
1	X	STN	Standby mode																																																																																																																																																																																																																																																																																																																					
<b>Pin status during operation control</b>																																																																																																																																																																																																																																																																																																																								
<table border="1"> <thead> <tr> <th>Pin No.</th> <th>Symbol</th> <th>CAM</th> <th>SLP</th> <th>STN</th> <th>RST*</th> <th>Pin No.</th> <th>Symbol</th> <th>CAM</th> <th>SLP</th> <th>STN</th> <th>RST*</th> </tr> </thead> <tbody> <tr><td>1</td><td>CKO</td><td>ACT</td><td>ACT</td><td>ACT</td><td>ACT</td><td>25</td><td>MCK</td><td>ACT</td><td>ACT</td><td>ACT</td><td>ACT</td></tr> <tr><td>2</td><td>Vss0</td><td>—</td><td>—</td><td>—</td><td>—</td><td>26</td><td>VDD1</td><td>—</td><td>—</td><td>—</td><td>—</td></tr> <tr><td>3</td><td>CKI</td><td>ACT</td><td>ACT</td><td>ACT</td><td>ACT</td><td>27</td><td>2MCK</td><td>ACT</td><td>ACT</td><td>ACT</td><td>ACT</td></tr> <tr><td>4</td><td>OSCO</td><td>ACT</td><td>ACT</td><td>ACT</td><td>ACT</td><td>28</td><td>TEST2</td><td>—</td><td>—</td><td>—</td><td>—</td></tr> <tr><td>5</td><td>OSCI</td><td>ACT</td><td>ACT</td><td>ACT</td><td>ACT</td><td>29</td><td>SEN</td><td>ACT</td><td>ACT</td><td>—</td><td>—</td></tr> <tr><td>6</td><td>VDD0</td><td>—</td><td>—</td><td>—</td><td>—</td><td>30</td><td>SSK</td><td>ACT</td><td>ACT</td><td>—</td><td>—</td></tr> <tr><td>7</td><td>TEST1</td><td>—</td><td>—</td><td>—</td><td>—</td><td>31</td><td>SSI</td><td>ACT</td><td>ACT</td><td>—</td><td>—</td></tr> <tr><td>8</td><td>AVD0</td><td>—</td><td>—</td><td>—</td><td>—</td><td>32</td><td>ID</td><td>ACT</td><td>L</td><td>L</td><td>L</td></tr> <tr><td>9</td><td>RG</td><td>ACT</td><td>L</td><td>L</td><td>L</td><td>33</td><td>EXP</td><td>ACT</td><td>L</td><td>L</td><td>L</td></tr> <tr><td>10</td><td>Vss1</td><td>—</td><td>—</td><td>—</td><td>—</td><td>34</td><td>HRO</td><td>ACT</td><td>ACT</td><td>L</td><td>L</td></tr> <tr><td>11</td><td>Vss2</td><td>—</td><td>—</td><td>—</td><td>—</td><td>35</td><td>FRO</td><td>ACT</td><td>ACT</td><td>L</td><td>L</td></tr> <tr><td>12</td><td>H1</td><td>ACT</td><td>L</td><td>L</td><td>L</td><td>36</td><td>Vss4</td><td>—</td><td>—</td><td>—</td><td>—</td></tr> <tr><td>13</td><td>H2</td><td>ACT</td><td>L</td><td>L</td><td>L</td><td>37</td><td>HRI</td><td>ACT</td><td>ACT</td><td>—</td><td>—</td></tr> <tr><td>14</td><td>AVD1</td><td>—</td><td>—</td><td>—</td><td>—</td><td>38</td><td>FRI</td><td>ACT</td><td>ACT</td><td>—</td><td>—</td></tr> <tr><td>15</td><td>XCPDM</td><td>ACT</td><td>L</td><td>L</td><td>L</td><td>39</td><td>VM</td><td>—</td><td>—</td><td>—</td><td>—</td></tr> <tr><td>16</td><td>AVD2</td><td>—</td><td>—</td><td>—</td><td>—</td><td>40</td><td>V1</td><td>ACT</td><td>VM</td><td>VM</td><td>VM</td></tr> <tr><td>17</td><td>XSHP</td><td>ACT</td><td>L</td><td>L</td><td>L</td><td>41</td><td>V3</td><td>ACT</td><td>VM</td><td>VM</td><td>VM</td></tr> <tr><td>18</td><td>XSHD</td><td>ACT</td><td>L</td><td>L</td><td>L</td><td>42</td><td>V2A</td><td>ACT</td><td>VH</td><td>VH</td><td>VH</td></tr> <tr><td>19</td><td>XRS</td><td>ACT</td><td>L</td><td>L</td><td>L</td><td>43</td><td>VH</td><td>—</td><td>—</td><td>—</td><td>—</td></tr> <tr><td>20</td><td>Vss3</td><td>—</td><td>—</td><td>—</td><td>—</td><td>44</td><td>V2B</td><td>ACT</td><td>VH</td><td>VH</td><td>VH</td></tr> <tr><td>21</td><td>PBLK</td><td>ACT</td><td>L</td><td>L</td><td>L</td><td>45</td><td>SUB</td><td>ACT</td><td>VH</td><td>VH</td><td>VH</td></tr> <tr><td>22</td><td>XCPOB</td><td>ACT</td><td>L</td><td>L</td><td>L</td><td>46</td><td>VL</td><td>—</td><td>—</td><td>—</td><td>—</td></tr> <tr><td>23</td><td>ADCLK</td><td>ACT</td><td>L</td><td>L</td><td>L</td><td>47</td><td>DSGAT</td><td>ACT</td><td>ACT</td><td>L</td><td>L</td></tr> <tr><td>24</td><td>RST</td><td>ACT</td><td>ACT</td><td>ACT</td><td>ACT</td><td>48</td><td>PS</td><td>ACT</td><td>ACT</td><td>ACT</td><td>ACT</td></tr> </tbody> </table>													Pin No.	Symbol	CAM	SLP	STN	RST*	Pin No.	Symbol	CAM	SLP	STN	RST*	1	CKO	ACT	ACT	ACT	ACT	25	MCK	ACT	ACT	ACT	ACT	2	Vss0	—	—	—	—	26	VDD1	—	—	—	—	3	CKI	ACT	ACT	ACT	ACT	27	2MCK	ACT	ACT	ACT	ACT	4	OSCO	ACT	ACT	ACT	ACT	28	TEST2	—	—	—	—	5	OSCI	ACT	ACT	ACT	ACT	29	SEN	ACT	ACT	—	—	6	VDD0	—	—	—	—	30	SSK	ACT	ACT	—	—	7	TEST1	—	—	—	—	31	SSI	ACT	ACT	—	—	8	AVD0	—	—	—	—	32	ID	ACT	L	L	L	9	RG	ACT	L	L	L	33	EXP	ACT	L	L	L	10	Vss1	—	—	—	—	34	HRO	ACT	ACT	L	L	11	Vss2	—	—	—	—	35	FRO	ACT	ACT	L	L	12	H1	ACT	L	L	L	36	Vss4	—	—	—	—	13	H2	ACT	L	L	L	37	HRI	ACT	ACT	—	—	14	AVD1	—	—	—	—	38	FRI	ACT	ACT	—	—	15	XCPDM	ACT	L	L	L	39	VM	—	—	—	—	16	AVD2	—	—	—	—	40	V1	ACT	VM	VM	VM	17	XSHP	ACT	L	L	L	41	V3	ACT	VM	VM	VM	18	XSHD	ACT	L	L	L	42	V2A	ACT	VH	VH	VH	19	XRS	ACT	L	L	L	43	VH	—	—	—	—	20	Vss3	—	—	—	—	44	V2B	ACT	VH	VH	VH	21	PBLK	ACT	L	L	L	45	SUB	ACT	VH	VH	VH	22	XCPOB	ACT	L	L	L	46	VL	—	—	—	—	23	ADCLK	ACT	L	L	L	47	DSGAT	ACT	ACT	L	L	24	RST	ACT	ACT	ACT	ACT	48	PS	ACT	ACT	ACT	ACT
Pin No.	Symbol	CAM	SLP	STN	RST*	Pin No.	Symbol	CAM	SLP	STN	RST*																																																																																																																																																																																																																																																																																																													
1	CKO	ACT	ACT	ACT	ACT	25	MCK	ACT	ACT	ACT	ACT																																																																																																																																																																																																																																																																																																													
2	Vss0	—	—	—	—	26	VDD1	—	—	—	—																																																																																																																																																																																																																																																																																																													
3	CKI	ACT	ACT	ACT	ACT	27	2MCK	ACT	ACT	ACT	ACT																																																																																																																																																																																																																																																																																																													
4	OSCO	ACT	ACT	ACT	ACT	28	TEST2	—	—	—	—																																																																																																																																																																																																																																																																																																													
5	OSCI	ACT	ACT	ACT	ACT	29	SEN	ACT	ACT	—	—																																																																																																																																																																																																																																																																																																													
6	VDD0	—	—	—	—	30	SSK	ACT	ACT	—	—																																																																																																																																																																																																																																																																																																													
7	TEST1	—	—	—	—	31	SSI	ACT	ACT	—	—																																																																																																																																																																																																																																																																																																													
8	AVD0	—	—	—	—	32	ID	ACT	L	L	L																																																																																																																																																																																																																																																																																																													
9	RG	ACT	L	L	L	33	EXP	ACT	L	L	L																																																																																																																																																																																																																																																																																																													
10	Vss1	—	—	—	—	34	HRO	ACT	ACT	L	L																																																																																																																																																																																																																																																																																																													
11	Vss2	—	—	—	—	35	FRO	ACT	ACT	L	L																																																																																																																																																																																																																																																																																																													
12	H1	ACT	L	L	L	36	Vss4	—	—	—	—																																																																																																																																																																																																																																																																																																													
13	H2	ACT	L	L	L	37	HRI	ACT	ACT	—	—																																																																																																																																																																																																																																																																																																													
14	AVD1	—	—	—	—	38	FRI	ACT	ACT	—	—																																																																																																																																																																																																																																																																																																													
15	XCPDM	ACT	L	L	L	39	VM	—	—	—	—																																																																																																																																																																																																																																																																																																													
16	AVD2	—	—	—	—	40	V1	ACT	VM	VM	VM																																																																																																																																																																																																																																																																																																													
17	XSHP	ACT	L	L	L	41	V3	ACT	VM	VM	VM																																																																																																																																																																																																																																																																																																													
18	XSHD	ACT	L	L	L	42	V2A	ACT	VH	VH	VH																																																																																																																																																																																																																																																																																																													
19	XRS	ACT	L	L	L	43	VH	—	—	—	—																																																																																																																																																																																																																																																																																																													
20	Vss3	—	—	—	—	44	V2B	ACT	VH	VH	VH																																																																																																																																																																																																																																																																																																													
21	PBLK	ACT	L	L	L	45	SUB	ACT	VH	VH	VH																																																																																																																																																																																																																																																																																																													
22	XCPOB	ACT	L	L	L	46	VL	—	—	—	—																																																																																																																																																																																																																																																																																																													
23	ADCLK	ACT	L	L	L	47	DSGAT	ACT	ACT	L	L																																																																																																																																																																																																																																																																																																													
24	RST	ACT	ACT	ACT	ACT	48	PS	ACT	ACT	ACT	ACT																																																																																																																																																																																																																																																																																																													
D17 to D18 STB	* See "6. RST pulse" for a detailed description of RST.																																																																																																																																																																																																																																																																																																																							
	<b>Note)</b> ACT indicates circuit operation, and L indicates "low" output level in the controlled status. For sleep mode or standby mode, stop supplying VH and VL power supplies with CCD image sensor.																																																																																																																																																																																																																																																																																																																							

Detailed description							
<p><b>D20</b> EXPXEN</p>	<p>0: The EXP pulse indicating the exposure period is generated (when PS = low). 1: The EXP pulse indicating the exposure period is not generated (when PS = low), and is constantly fixed to low.</p> <p>This bit is invalid when STATUS = 1. Note that the STB setting has priority.</p>						
<p><b>D21</b> to <b>D24</b></p>	<p>Invalid data</p>						
<p><b>D25</b> to <b>D29</b> VSHUT</p>	<p>Low-speed electronic shutter setting. The value set here is the number of FR during which readout operation is not performed even if there is input. The setting range is from "0" to "31". When set to "0", readout operation is performed at the first FR. When FS = 1, this bit is invalid.</p> <table border="1" style="width: 100%; border-collapse: collapse;"> <thead> <tr> <th style="text-align: left;">MSB</th> <th style="text-align: center;">LSB</th> <th style="text-align: left;">Function</th> </tr> </thead> <tbody> <tr> <td style="text-align: left;">D29 D28 D27 D26 D25</td> <td></td> <td>Number of FR during which readout operation is not performed</td> </tr> </tbody> </table>	MSB	LSB	Function	D29 D28 D27 D26 D25		Number of FR during which readout operation is not performed
MSB	LSB	Function					
D29 D28 D27 D26 D25		Number of FR during which readout operation is not performed					
<p><b>D30</b> to <b>D39</b></p>	<p>Invalid data</p>						

**CXD2460R clock system**

When using a 28.636MHz crystal

	FHIGH	FINE	MCK frequency	2MCK pin output	Frame rate	
Mode1	1	1	14.3MHz	28.6MHz	7.5Frame/s	Basic
Mode2	1	0	14.3MHz	28.6MHz	30Frame/s	DRAFT
Mode3	0	0	7.2MHz	14.3MHz	15Frame/s	Power-save

**Note)** Combinations of FHIGH and FINE other than those listed above are prohibited.



**CTGRY: Electronic shutter control data**

Detailed description							
<div style="border: 1px solid black; padding: 2px; display: inline-block;">D12</div> to <div style="border: 1px solid black; padding: 2px; display: inline-block;">D22</div> HSHUT	High-speed electronic shutter setting. The value set here is the number of SUB pulses from FR to the next FR. <table border="1" style="width: 100%; border-collapse: collapse; margin-top: 10px;"> <thead> <tr> <th style="text-align: left;">MSB</th> <th style="text-align: right;">LSB</th> <th>Function</th> </tr> </thead> <tbody> <tr> <td>D22 D21 D20 D19 D18 D17 D16 D15 D14 D13 D12</td> <td></td> <td>Number of SUB pulses setting</td> </tr> </tbody> </table>	MSB	LSB	Function	D22 D21 D20 D19 D18 D17 D16 D15 D14 D13 D12		Number of SUB pulses setting
MSB	LSB	Function					
D22 D21 D20 D19 D18 D17 D16 D15 D14 D13 D12		Number of SUB pulses setting					
<div style="border: 1px solid black; padding: 2px; display: inline-block;">D23</div> to <div style="border: 1px solid black; padding: 2px; display: inline-block;">D39</div>	Input "0".						

High-speed and low-speed electronic shutter can be used together. Therefore, the exposure time is as follows:

$$FR \text{ cycle} \times VSHUT + (fv - HSHUT) \times HR \text{ cycle} + 634/MCK \text{ frequency [Hz]} = \text{Exposure time [s]}$$

(fv: Number of HR in 1FR)

**CTGRY: System setting data**

		Detailed description																
<div style="border: 1px solid black; padding: 2px; display: inline-block;">D12</div> SGXEN		0: Internal SSG (Sync Signal Generator) functions operate to generate FRO and HRO. 1: Internal SSG functions are stopped, and the FRO and HRO pulses are fixed to low.  Note that the STB setting has priority. Set SGXEN to "1" in the case of input of a CXD2460R sync signal from the outside.																
<div style="border: 1px solid black; padding: 2px; display: inline-block;">D13</div> EXSG		0: Normal operation 1: XSGA and XSGB are output from the HRO and FRO pins.  Note that the output pulse amplitude is V <sub>SS</sub> to V <sub>DDA</sub> .																
<div style="border: 1px solid black; padding: 2px; display: inline-block;">D14</div> to <div style="border: 1px solid black; padding: 2px; display: inline-block;">D15</div> IDSEL		These bits select the pulse output from the ID pin.  <table border="1" style="margin-left: auto; margin-right: auto;"> <thead> <tr> <th colspan="2"></th> <th colspan="2">D15</th> </tr> <tr> <th colspan="2"></th> <th>0</th> <th>1</th> </tr> </thead> <tbody> <tr> <th rowspan="2">D14</th> <th>0</th> <td>ID pulse output</td> <td>WEN pulse output</td> </tr> <tr> <th>1</th> <td>XSUB pulse output</td> <td>ID pulse output</td> </tr> </tbody> </table> <p style="text-align: center;">XSUB: Inverted SUB pulse output at the amplitude of V<sub>SS</sub> to V<sub>DDA</sub></p>			D15				0	1	D14	0	ID pulse output	WEN pulse output	1	XSUB pulse output	ID pulse output	
		D15																
		0	1															
D14	0	ID pulse output	WEN pulse output															
	1	XSUB pulse output	ID pulse output															
<div style="border: 1px solid black; padding: 2px; display: inline-block;">D16</div> VTXEN		0: VT (readout clock) is added to V2A, V2B and V3 as normal. 1: VT is not added to V2A, V2B and V3.  During readout, only the modulation necessary for readout is performed. Note that this setting has priority over mode control data NSG (D14).																
<div style="border: 1px solid black; padding: 2px; display: inline-block;">D17</div> CHKSUM		0: Checksum is not performed and the checksum data is invalid. (However, dummy data must be set in the CHKSUM register.) 1: Checksum is performed. This data is reflected even if the checksum results are NG.																
<div style="border: 1px solid black; padding: 2px; display: inline-block;">D18</div> STATUS		0: The EXP pulse is output from the EXP pin. 1: High is indicated if the checksum results from the EXP pin are OK, and low if the results are NG.  This pulse is output at the rise of SEN, and reset high again at the fall of SEN. This pulse has priority over mode control data EXP.																
<div style="border: 1px solid black; padding: 2px; display: inline-block;">D19</div> to <div style="border: 1px solid black; padding: 2px; display: inline-block;">D22</div>		Input "0".																
<div style="border: 1px solid black; padding: 2px; display: inline-block;">D23</div> to <div style="border: 1px solid black; padding: 2px; display: inline-block;">D29</div> FVFS		These bits set the high-speed sweep period (unit: H) in FS mode.  <table border="1" style="margin-left: auto; margin-right: auto;"> <thead> <tr> <th colspan="7">MSB</th> <th>LSB</th> </tr> </thead> <tbody> <tr> <td>D29</td> <td>D28</td> <td>D27</td> <td>D26</td> <td>D25</td> <td>D24</td> <td>D23</td> <td></td> </tr> </tbody> </table> <p>The high-speed sweep is performed for 8 lines for every 1H when FINE = 1, and 20 lines for every 1H when FINE = 0.</p>	MSB							LSB	D29	D28	D27	D26	D25	D24	D23	
MSB							LSB											
D29	D28	D27	D26	D25	D24	D23												

Detailed description	
<div style="border: 1px solid black; padding: 2px; display: inline-block;">D30</div> XVCK	0: Normal operation 1: V1, V2 and V3 are inverted and output as XV1, XV2 and XV3. The amplitude is from VL to VM.
<div style="border: 1px solid black; padding: 2px; display: inline-block;">D31</div> to <div style="border: 1px solid black; padding: 2px; display: inline-block;">D39</div>	Invalid data

**CHKSUM**

Detailed description																								
<div style="border: 1px solid black; padding: 2px; display: inline-block;">D40</div> to <div style="border: 1px solid black; padding: 2px; display: inline-block;">D47</div>	These are the checksum bits.																							
	<table style="width: 100%; border-collapse: collapse;"> <tr> <td style="text-align: center;">MSB</td> <td style="text-align: center;">LSB</td> </tr> <tr> <td style="text-align: center;">D07 D06 D05 D04 D03 D02 D01 D00</td> <td></td> </tr> <tr> <td style="text-align: center;">D15 D14 D13 D12 D11 D10 D09 D08</td> <td></td> </tr> <tr> <td style="text-align: center;">D23 D22 D21 D20 D19 D18 D17 D16</td> <td></td> </tr> <tr> <td style="text-align: center;">D31 D30 D29 D28 D27 D26 D25 D24</td> <td></td> </tr> <tr> <td style="text-align: center;">D39 D38 D37 D36 D35 D34 D33 D32</td> <td></td> </tr> <tr> <td style="text-align: center;">+)</td> <td style="text-align: center;"> <table border="1" style="border-collapse: collapse; width: 100%;"> <tr> <td style="padding: 2px;">D47</td> <td style="padding: 2px;">D46</td> <td style="padding: 2px;">D45</td> <td style="padding: 2px;">D44</td> <td style="padding: 2px;">D43</td> <td style="padding: 2px;">D42</td> <td style="padding: 2px;">D41</td> <td style="padding: 2px;">D40</td> <td style="padding: 2px;">→</td> <td style="padding: 2px; border: 1px solid black;">CHKSUM</td> </tr> </table> </td> </tr> </table> <p style="text-align: center;">If the total = 0, the checksum results are OK.</p> <p>Serial data is loaded to the internal registers only when checksum is OK.                      Data is not reflected to the registers if checksum is NG.                      Also, when CHKSUM = 0, the checksum results are always OK and the data is reflected to the registers.</p>	MSB	LSB	D07 D06 D05 D04 D03 D02 D01 D00		D15 D14 D13 D12 D11 D10 D09 D08		D23 D22 D21 D20 D19 D18 D17 D16		D31 D30 D29 D28 D27 D26 D25 D24		D39 D38 D37 D36 D35 D34 D33 D32		+)	<table border="1" style="border-collapse: collapse; width: 100%;"> <tr> <td style="padding: 2px;">D47</td> <td style="padding: 2px;">D46</td> <td style="padding: 2px;">D45</td> <td style="padding: 2px;">D44</td> <td style="padding: 2px;">D43</td> <td style="padding: 2px;">D42</td> <td style="padding: 2px;">D41</td> <td style="padding: 2px;">D40</td> <td style="padding: 2px;">→</td> <td style="padding: 2px; border: 1px solid black;">CHKSUM</td> </tr> </table>	D47	D46	D45	D44	D43	D42	D41	D40	→
MSB	LSB																							
D07 D06 D05 D04 D03 D02 D01 D00																								
D15 D14 D13 D12 D11 D10 D09 D08																								
D23 D22 D21 D20 D19 D18 D17 D16																								
D31 D30 D29 D28 D27 D26 D25 D24																								
D39 D38 D37 D36 D35 D34 D33 D32																								
+)	<table border="1" style="border-collapse: collapse; width: 100%;"> <tr> <td style="padding: 2px;">D47</td> <td style="padding: 2px;">D46</td> <td style="padding: 2px;">D45</td> <td style="padding: 2px;">D44</td> <td style="padding: 2px;">D43</td> <td style="padding: 2px;">D42</td> <td style="padding: 2px;">D41</td> <td style="padding: 2px;">D40</td> <td style="padding: 2px;">→</td> <td style="padding: 2px; border: 1px solid black;">CHKSUM</td> </tr> </table>	D47	D46	D45	D44	D43	D42	D41	D40	→	CHKSUM													
D47	D46	D45	D44	D43	D42	D41	D40	→	CHKSUM															

**4. Shutter speed setting specifications when PS = H**

When PS = H, the CXD2460R can be controlled without inputting serial data by using the SEN, SSK and SSI pins.

Pin		When L	When H													
SEN	FHIGH (horizontal drive frequency)	Serial register FHIGH = 0.	Serial register FHIGH = 1.													
SSK	FINE (readout method)	Serial register FINE = 0 and the CXD2460R operates in DRAFT mode.	Serial register FINE = 1 and the CXD2460R operates in FINE mode.													
SSI	HSHUT, VSHUT (exposure time)	<p style="text-align: center;">Number of SUB pulses when PS = H</p> <table border="1" style="margin-left: auto; margin-right: auto;"> <thead> <tr> <th colspan="2" rowspan="2"></th> <th colspan="2">SSK</th> </tr> <tr> <th>L</th> <th>H</th> </tr> </thead> <tbody> <tr> <th rowspan="2">SEN</th> <th>L</th> <td>251 201</td> <td>1052 1002</td> </tr> <tr> <th>H</th> <td>235 134</td> <td>1034 935</td> </tr> </tbody> </table> <p style="text-align: right;">Upper number: When SSI = H (1/250) Lower number: When SSI = L (1/60)</p>				SSK		L	H	SEN	L	251 201	1052 1002	H	235 134	1034 935
		SSK														
		L	H													
SEN	L	251 201	1052 1002													
	H	235 134	1034 935													

Other registers hold the value input when PS = L, and assume the status indicated by STB when the RST pulse is input.

## 5. Reflection position of each data

Each serial data is reflected at the timing shown in the table below. The reflection position is the same when PS = H. When using the low-speed electronic shutter, the data is not reflected at FR where XSG is not generated (a readout pulse is not added to V2A).

**Table 5-1. Serial data reflection timing**

Data	Reflection position
Mode control data (STB)	SEN rise
Mode control data (EXPXEN)	XSGA pulse rise
Mode control data (other than STB and EXPXEN)	HRI* <sup>1</sup> fall just before XSGA pulse generation
Electronic shutter control data	HRI* <sup>2</sup> fall just after XSGA pulse generation
High-speed phase adjustment data	HRI* <sup>1</sup> fall just before XSGA pulse generation
System setting data (SGXEN)	SEN rise
System setting data (other than SGXEN)	HRI* <sup>2</sup> fall just before XSGA pulse generation

\*<sup>1</sup> For FS mode, 7HRI later from FRI fall.

\*<sup>2</sup> For FS mode, 8HRI later from FRI fall.

## 6. RST pulse

Setting Pin 30 to low resets the system. The serial data values after reset are as shown in the "Serial data" table.

Also, some internal circuits stop operating when RST = L. For a description of the pin status when RST = L, see the "Pin status during operation control" table given in the detailed description of STB under "3. Serial data and description of functions".

## 7. DSGAT

DSGAT is ON when low and the CXD2460R is set to sleep mode as with SLP of STB.

Note that control is applied when either or both of DSGAT and SLP are ON. Also, when STN is ON, the CXD2460R is set to standby mode regardless of the DSGAT status.

## 8. EXP pulse

The EXP pulse indicates the exposure period.

The details are shown on the following pages.

(1) HSHUT ≥ MAX

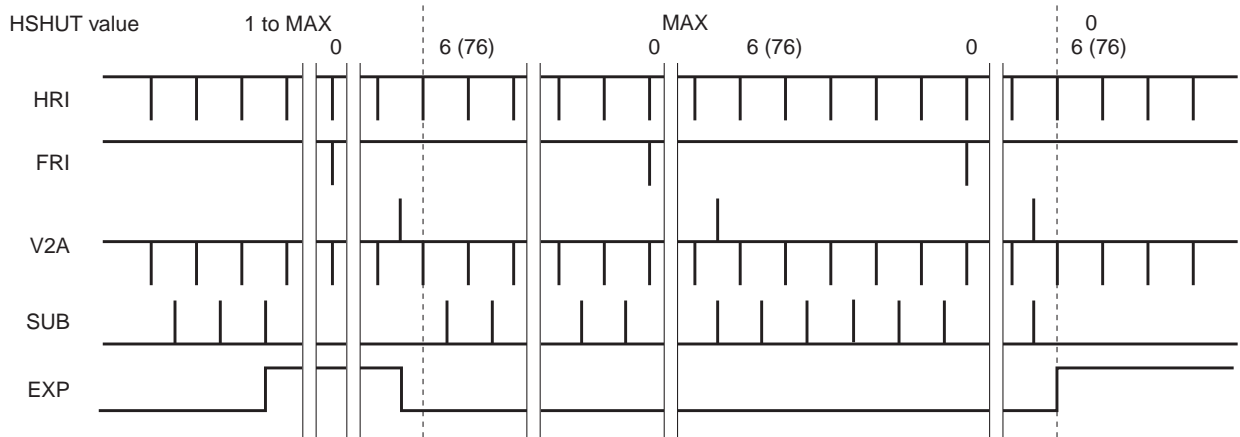

(2) HSHUT ≥ MAX (with low-speed electronic shutter)

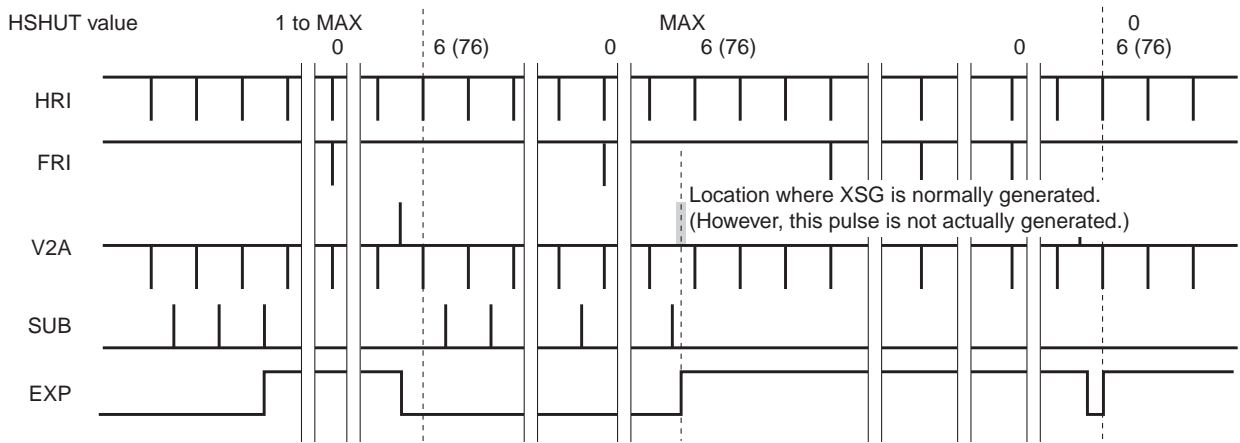

(3) 1 ≤ HSHUT < MAX

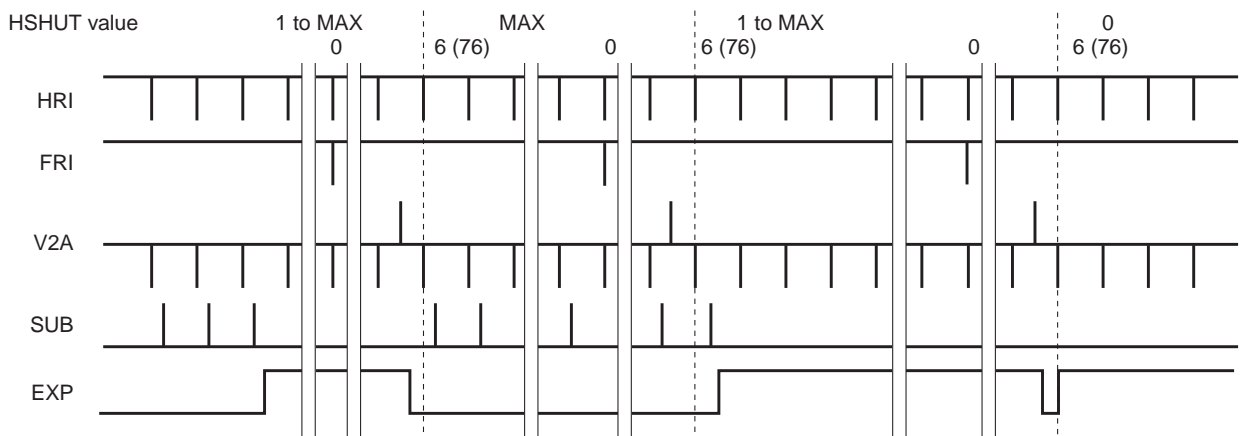

Numbers in parentheses are for FS mode.

(4)  $1 \leq \text{HSHUT} < \text{MAX}$  (with low-speed electronic shutter)

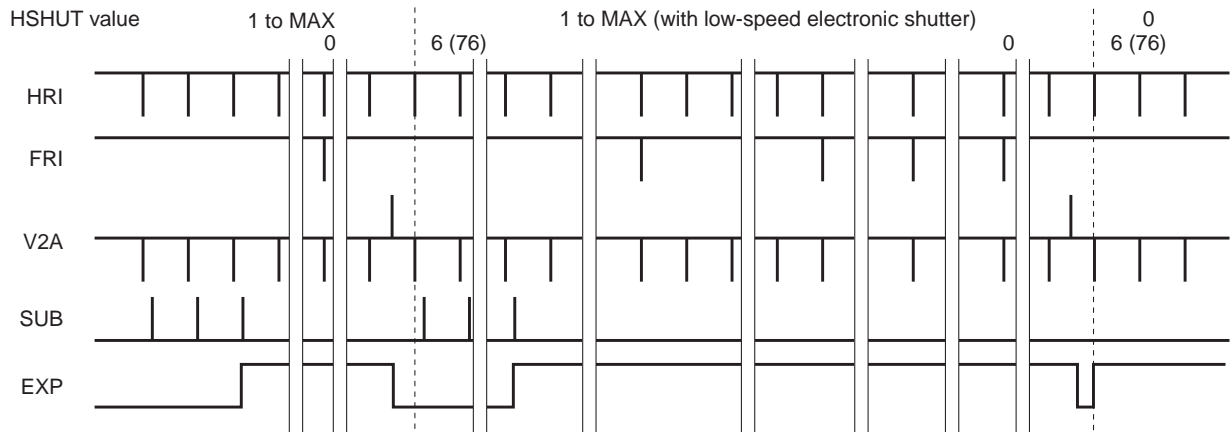

(5)  $\text{HSHUT} = 0$

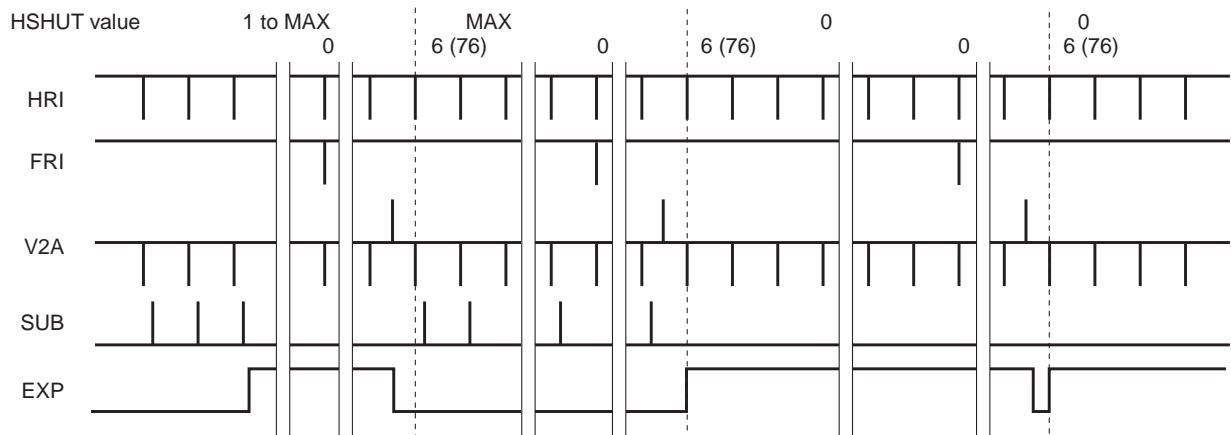

(6)  $\text{HSHUT} = 0$  (with low-speed electronic shutter)

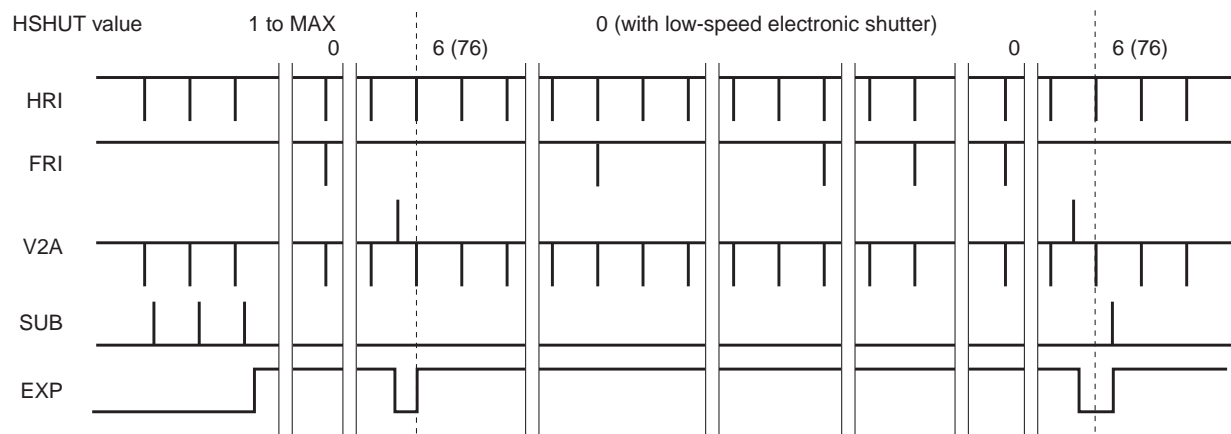

Numbers in parentheses are for FS mode.

Chart A-1. FINE Mode (Vertical synchronization)

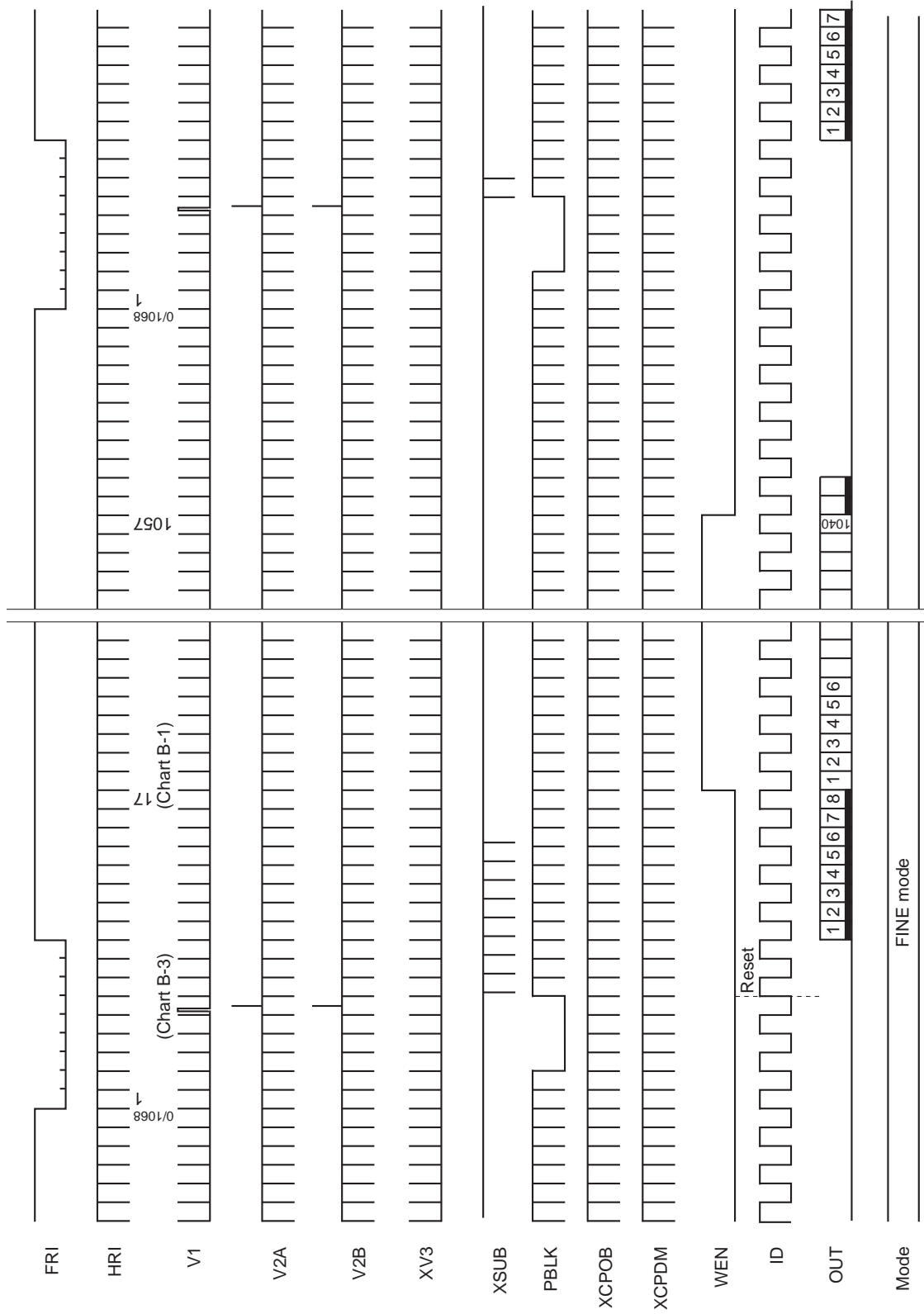



Chart A-2. DRAFT Mode (Vertical synchronization)

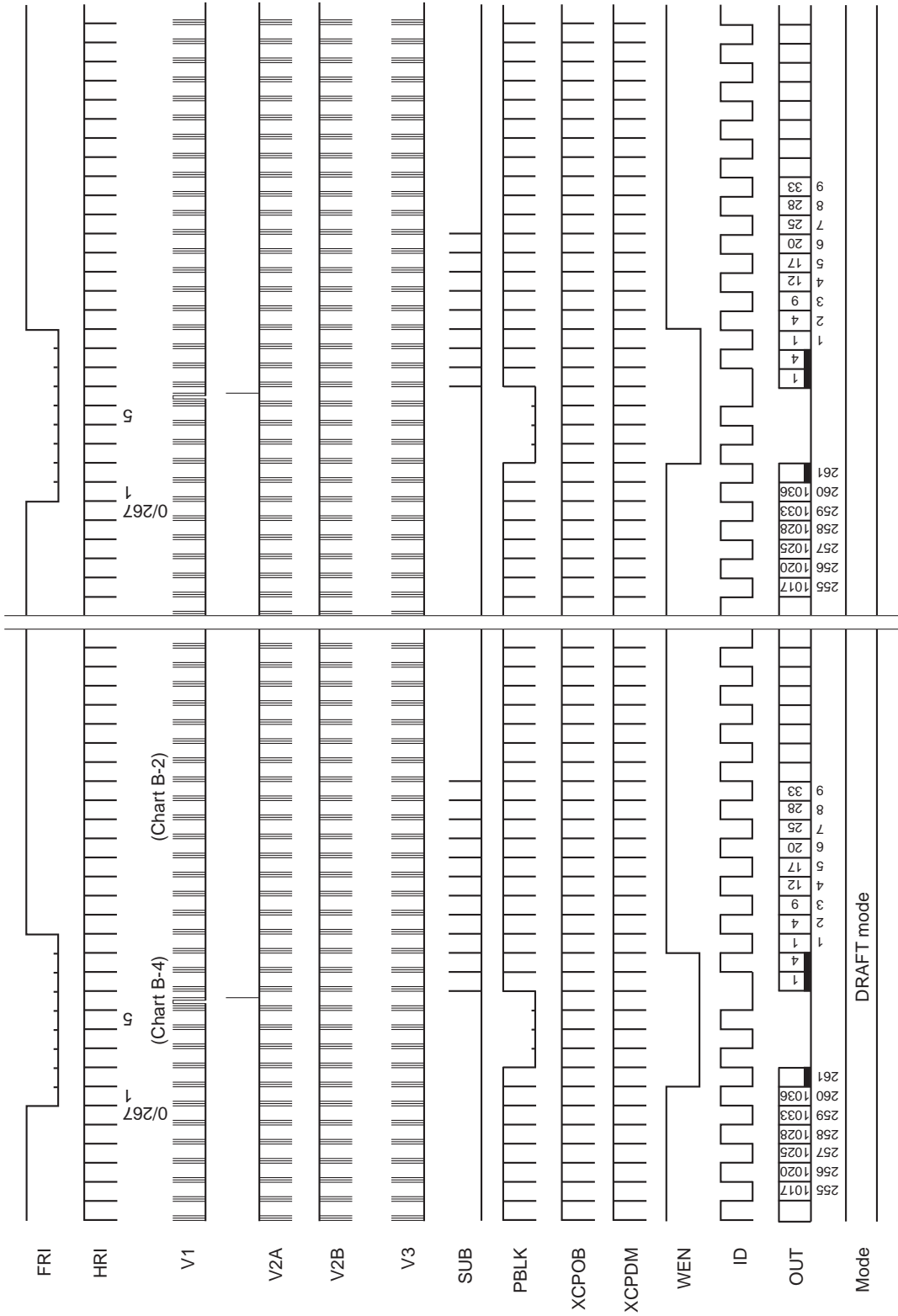
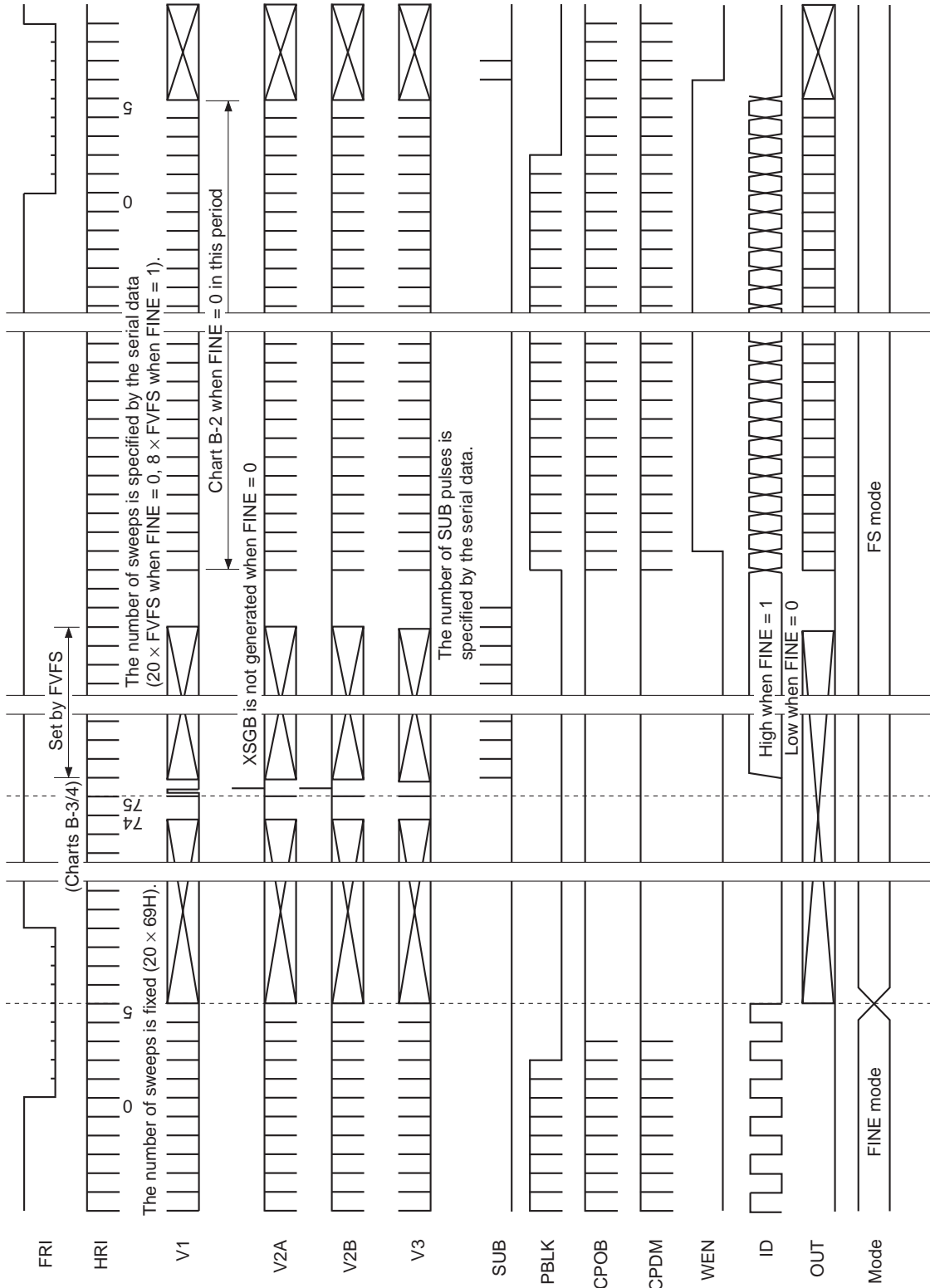

Chart A-3. FS Mode (Vertical synchronization)



The mode is switched at the point where XSG is normally generated.

Chart B-1. FINE Mode (Horizontal synchronization)

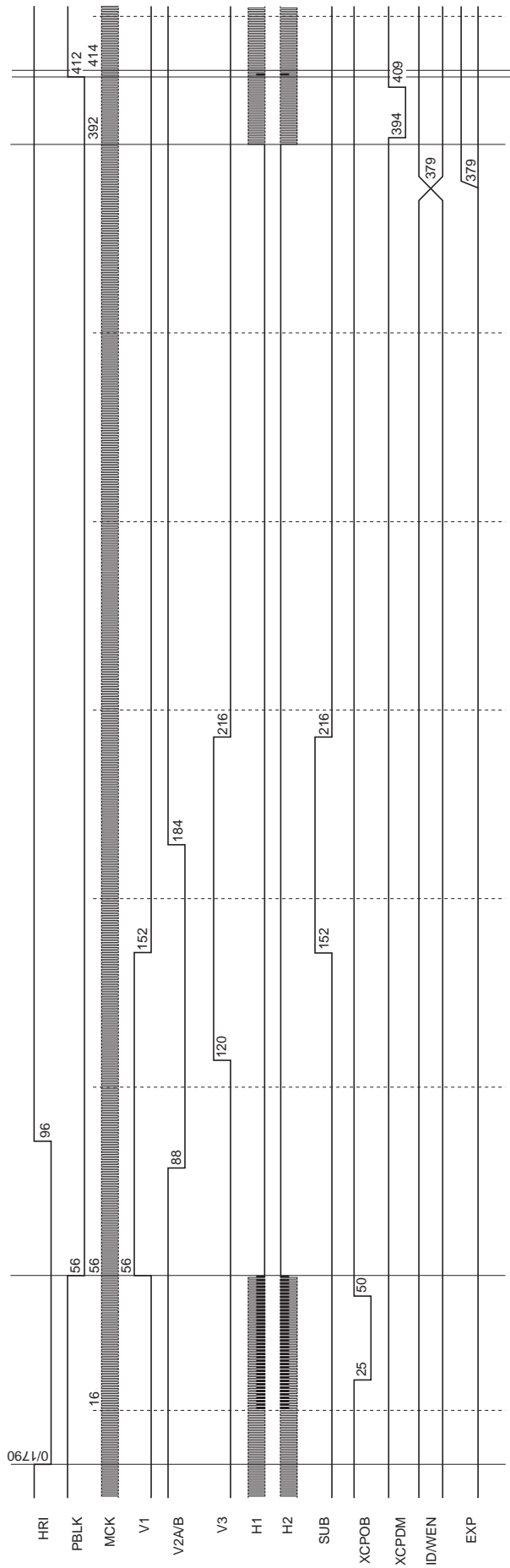

Chart B-2. DRAFT Mode (Horizontal synchronization)

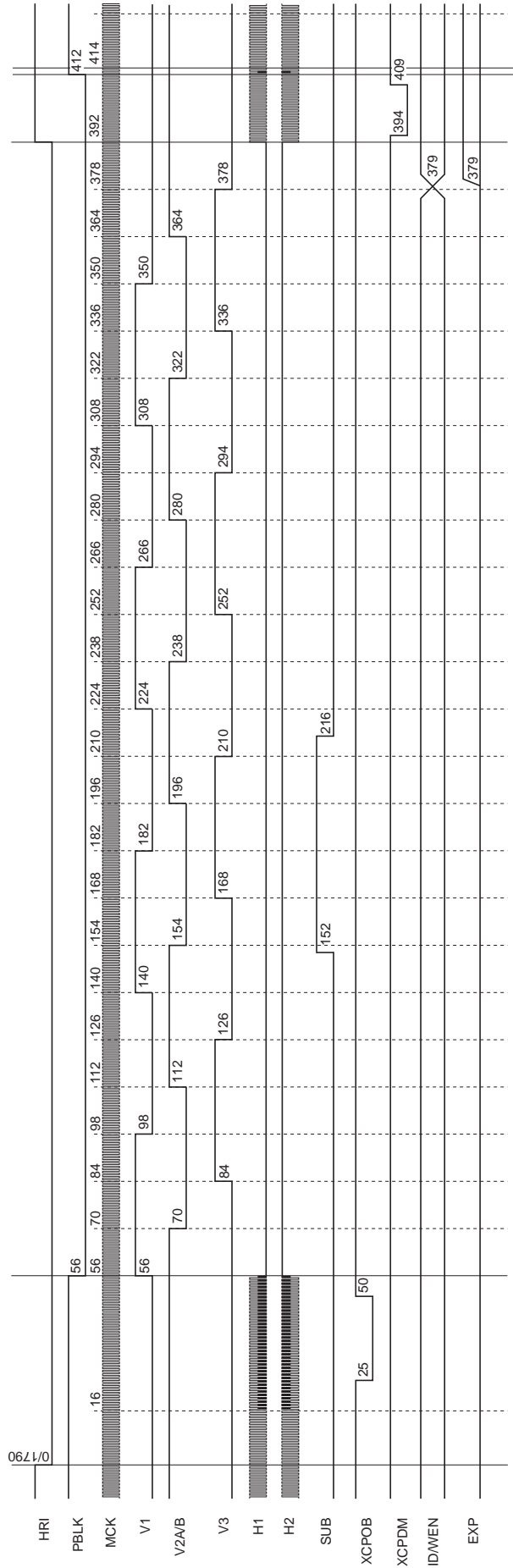

Chart B-3. Readout Timing (FINE mode)

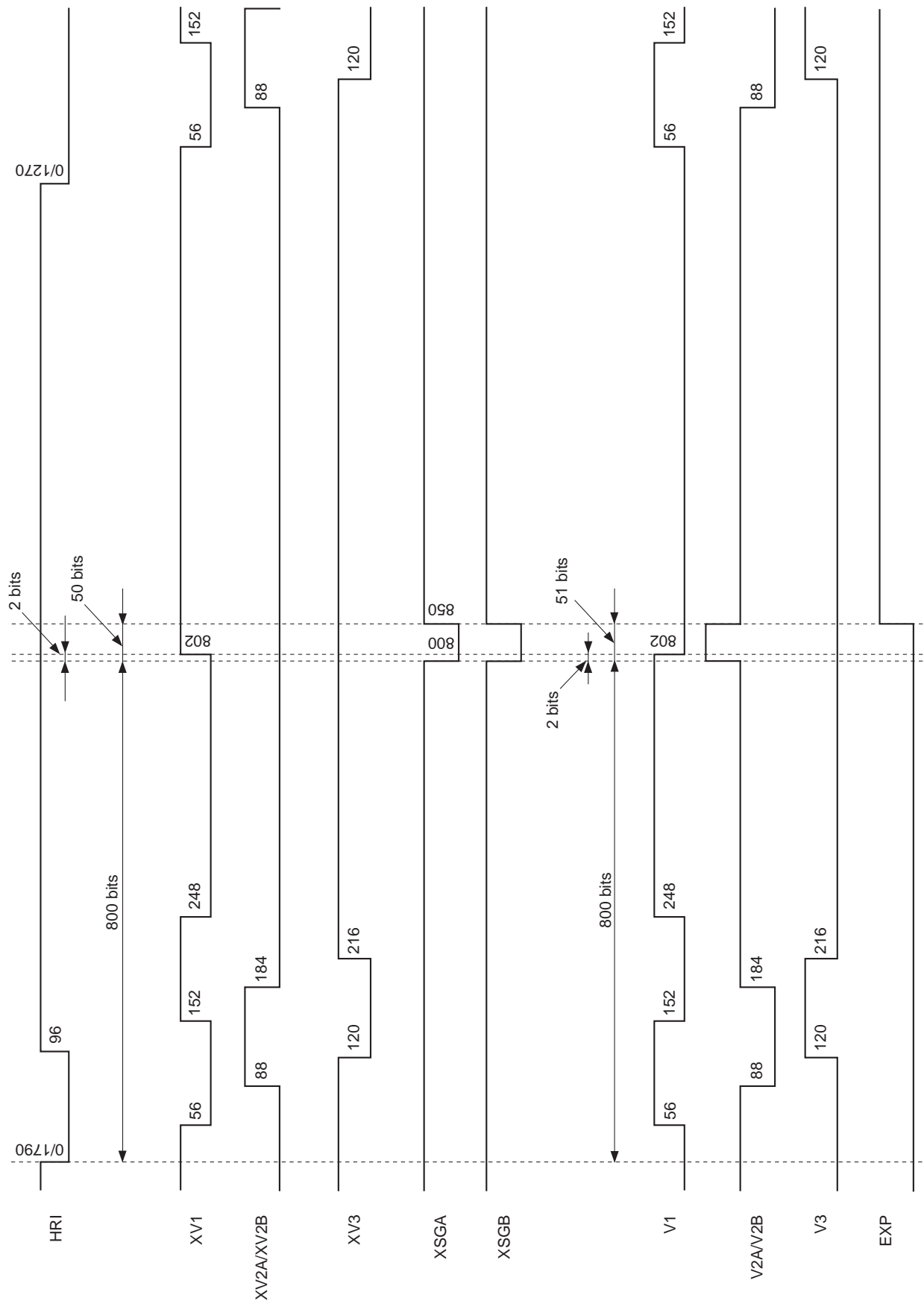

Chart B-4. Readout Timing (DRAFT mode)

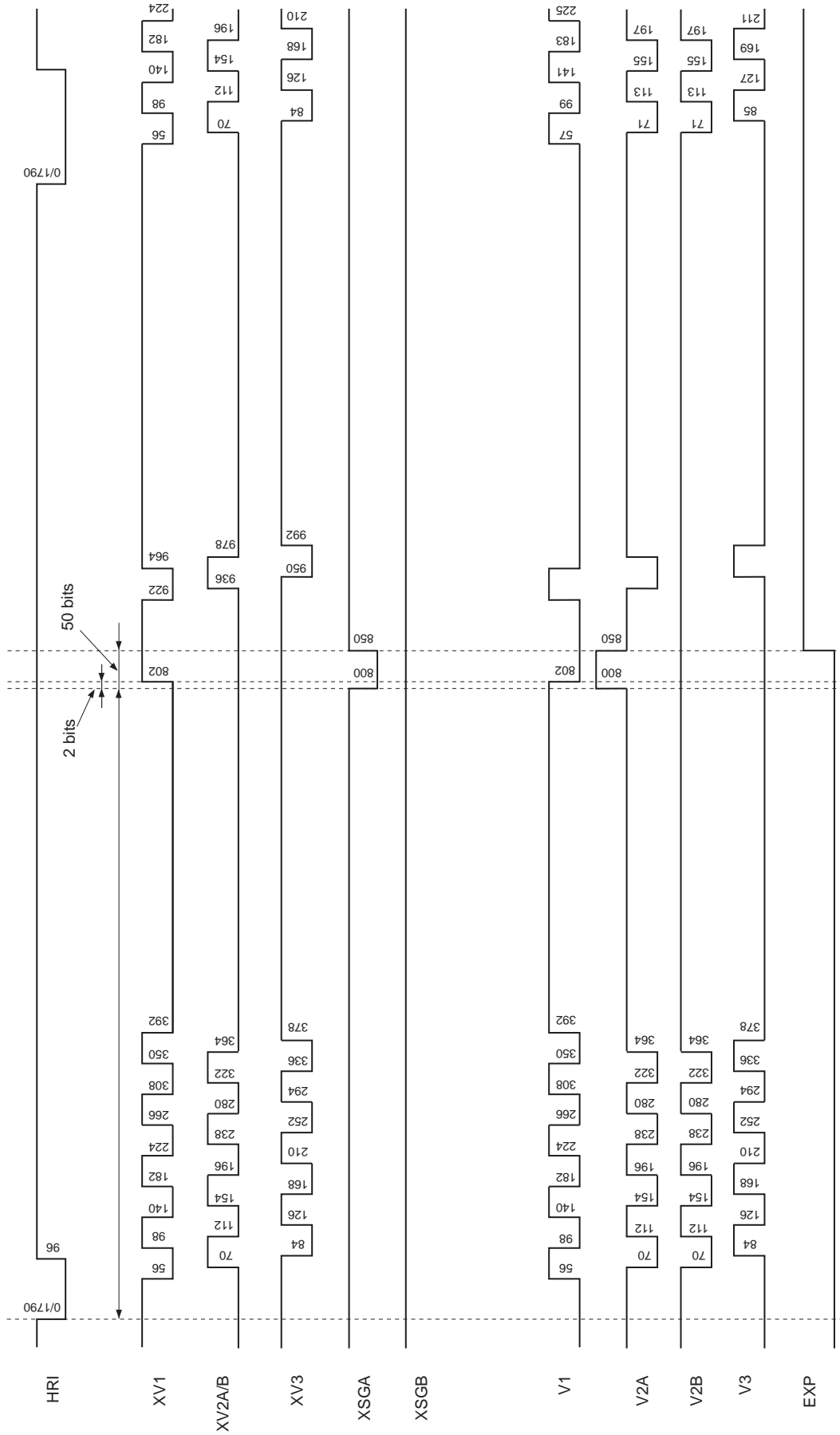

Chart B-5. FS Mode: V clock continuous drive (FINE = 1)

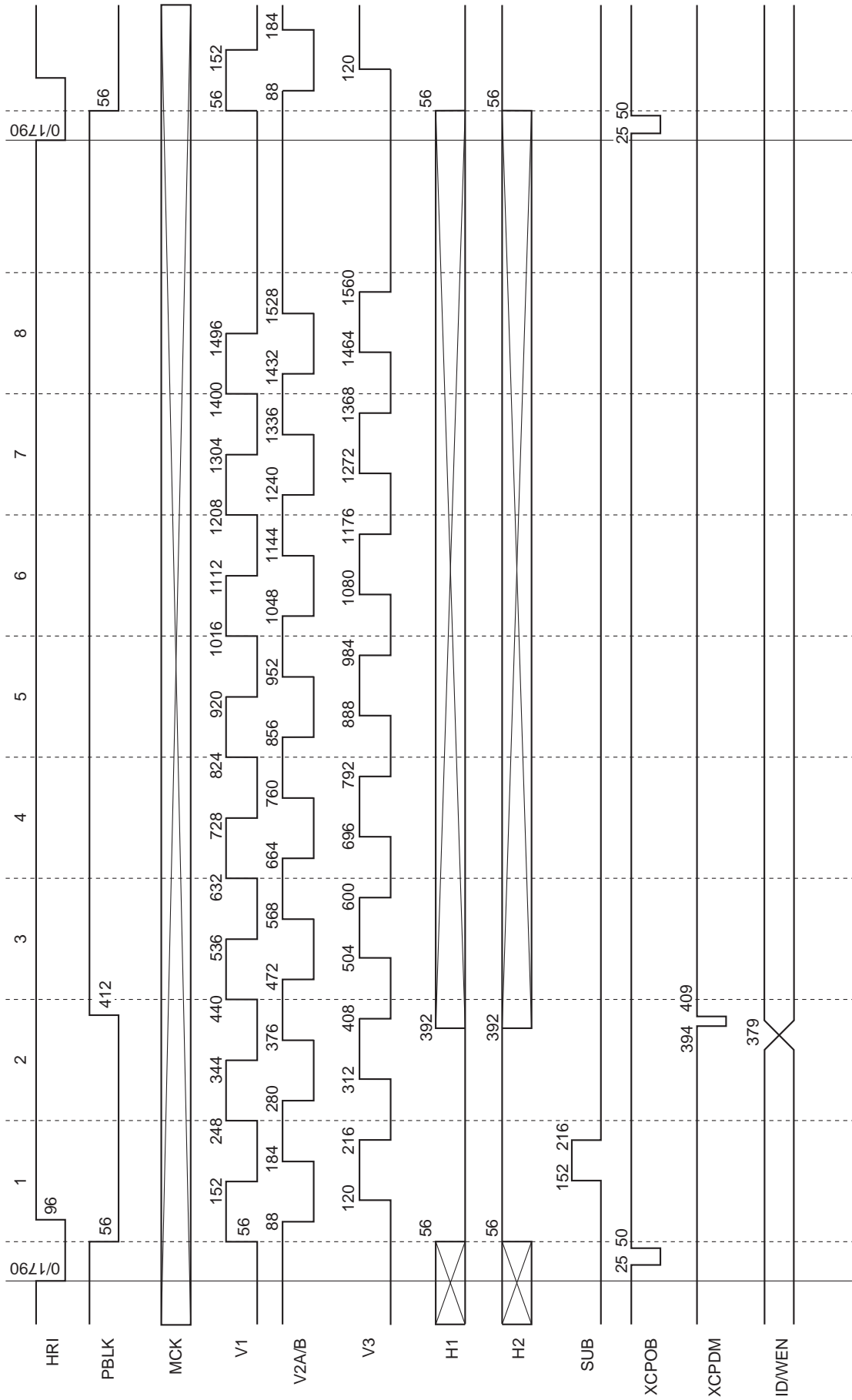
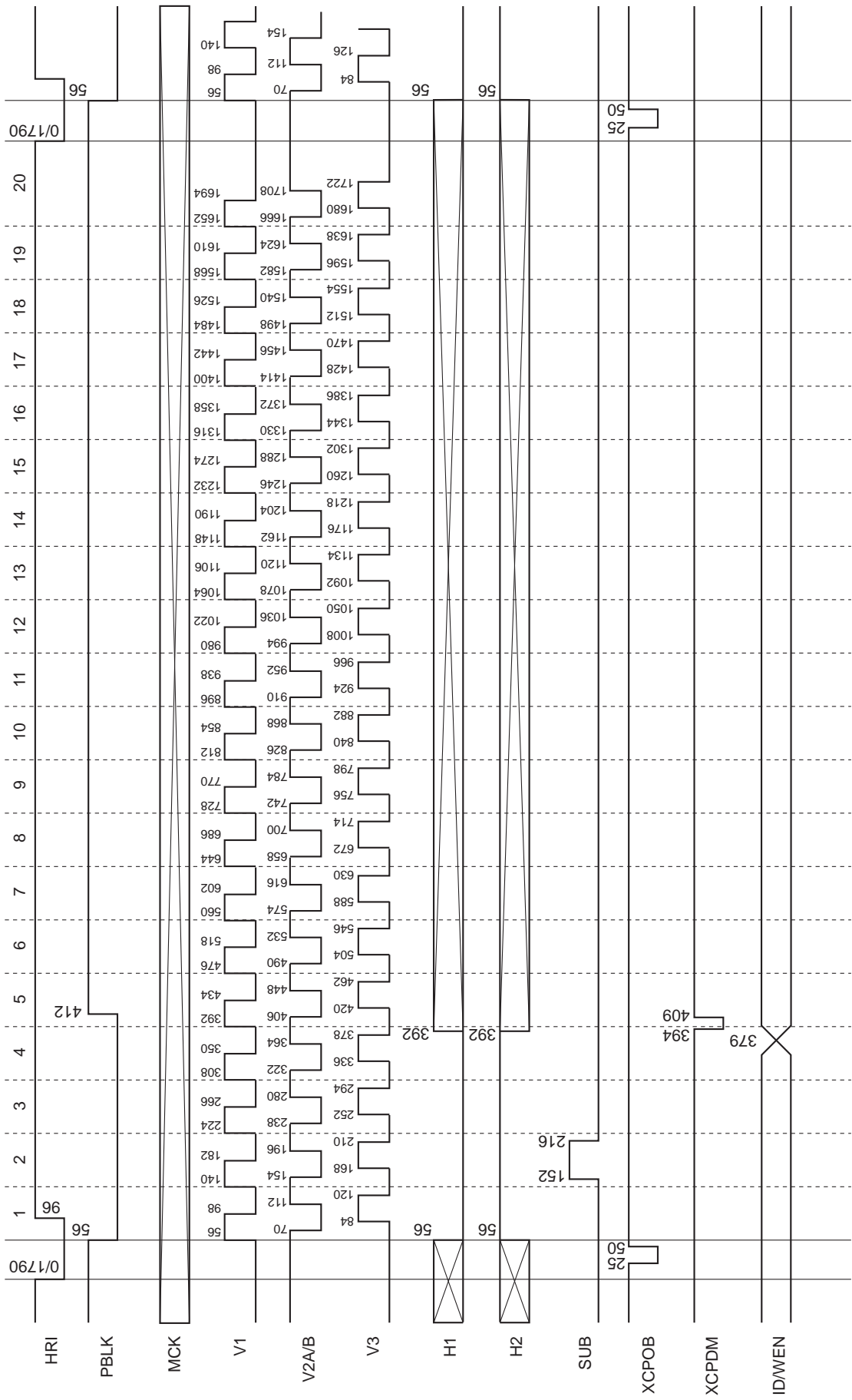
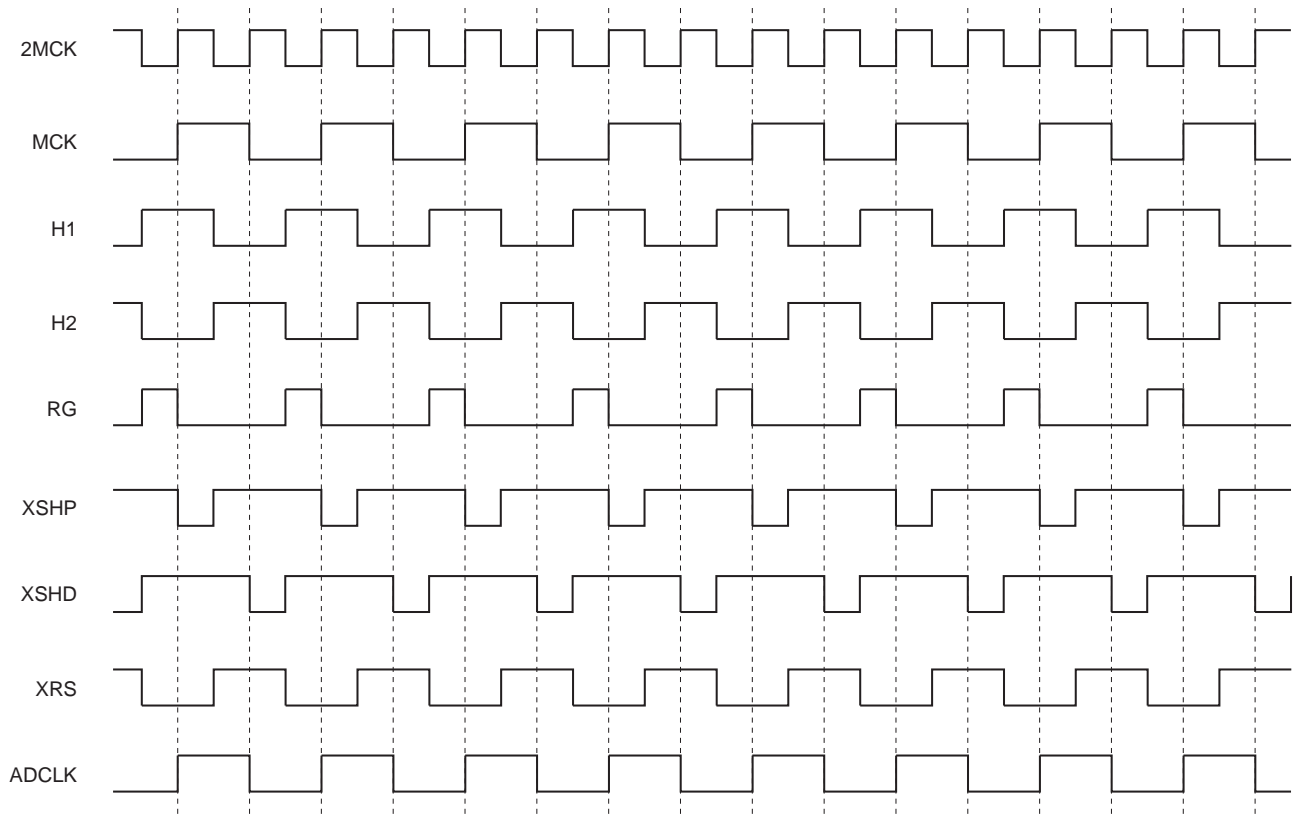

Chart B-6. FS Mode: V clock continuous drive (FINE = 0)





Logical Phase



Application Circuit

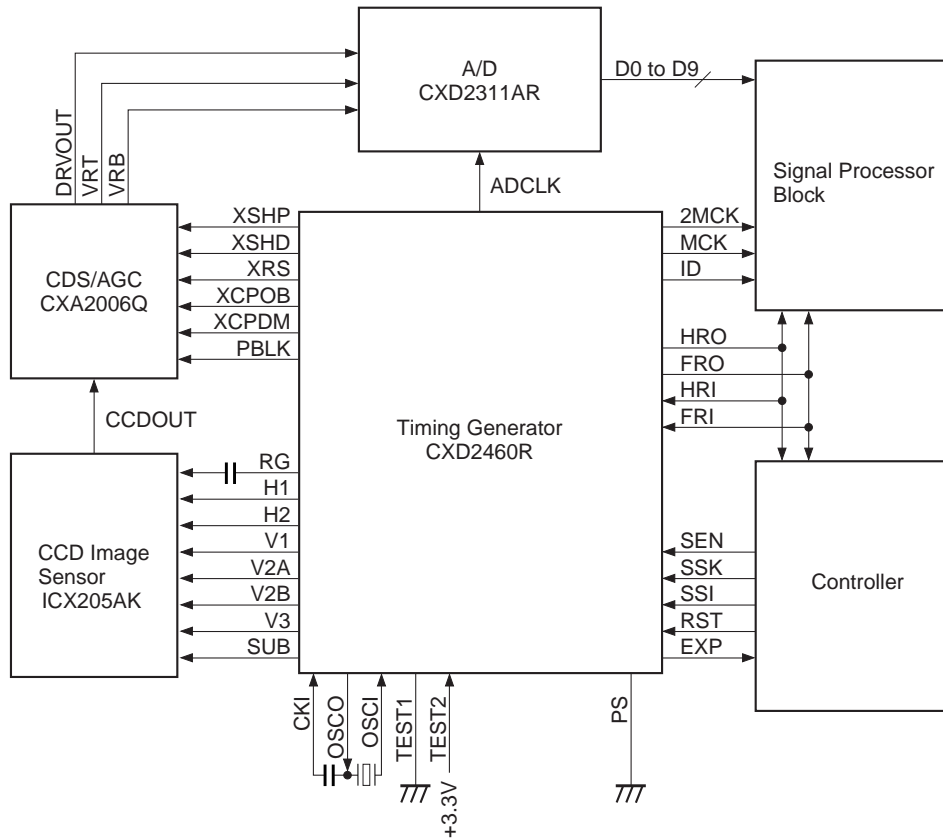

For making FR and HR outside the CXD2460R, configure a circuit that counts MCK. (Using 2MCK, CKO, etc. is not recommended.) Also, set system setting data, SGXEN (D12) to "1" and stop a built-in SSG. Use crystal oscillator (fundamental wave) as base oscillation. Be sure to input duty 50% pulse when crystal oscillator is used.

Application circuits shown are typical examples illustrating the operation of the devices. Sony cannot assume responsibility for any problems arising out of the use of these circuits or for any infringement of third party patent and other right due to same.

**Notes on Turning Power ON**

To avoid setting VSUB pin of the CCD image sensor negative potential, the former two power supplies should be raised by the following order among three power supplies, VL and VH.

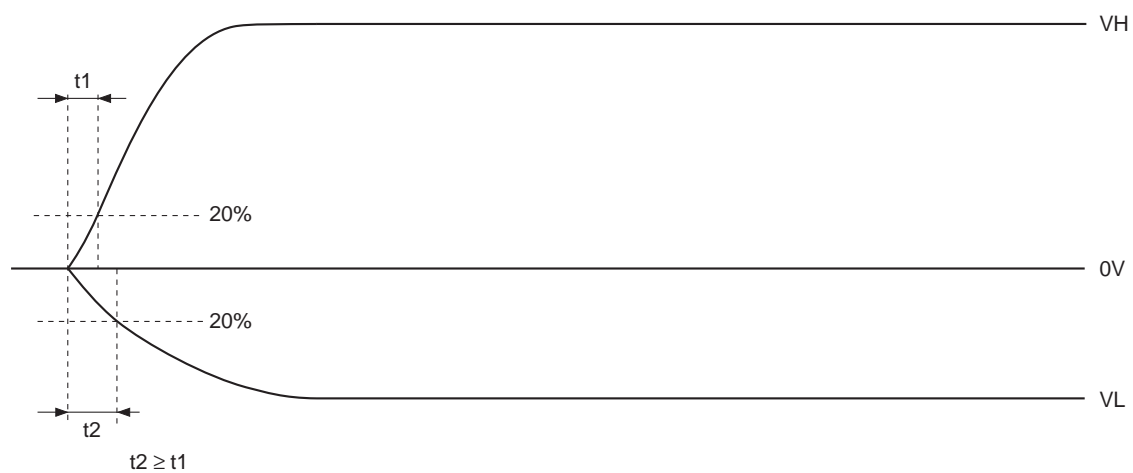

Package Outline Unit: mm

48PIN LQFP (PLASTIC)

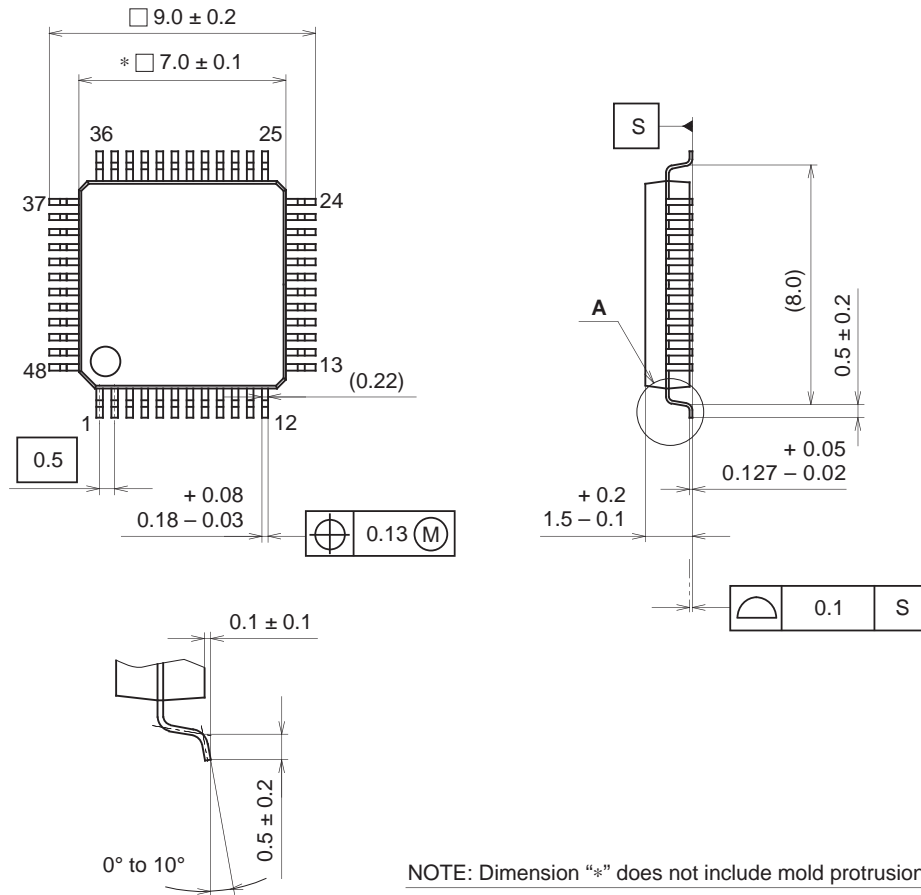

DETAIL A

PACKAGE STRUCTURE

SONY CODE	LQFP-48P-L01
EIAJ CODE	LQFP048-P-0707
JEDEC CODE	_____

PACKAGE MATERIAL	EPOXY RESIN
LEAD TREATMENT	SOLDER/PALLADIUM PLATING
LEAD MATERIAL	42/COPPER ALLOY
PACKAGE MASS	0.2g