

SONY

CXG1014N

1.5 GHz Low Noise Amplifier/Down Conversion Mixer

Description

The CXG1014N is a low noise amplifier/down conversion mixer MMIC, designed using the Sony's GaAs J-FET process.

Features

- Low noise
 NF=1.85 dB (Typ.) at 1.49 GHz
 (low noise amplifier)
- Low distortion
 Input IP3=+2 dBm (Typ.) at 1.49 GHz
 (mixer)
- Low LO input power operation -15 dBm
- Single 3.0 V power supply operation
- 16-pin SSOP package

Applications

1.5 GHz Japan digital cellular telephones

Structure

GaAs J-FET MMIC

16 pin SSOP (Plastic)

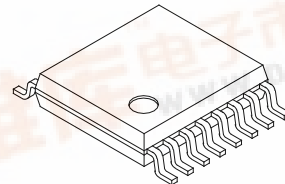

Absolute Maximum Ratings (Ta=25 °C)

- Supply voltage V_{DD} 6 V
- Operating temperature Topr -35 to +85 °C
- Storage temperature Tstg -65 to +150 °C
- Power dissipation P_D 150 mW
- Current consumption
 - I_{DD} (low noise amplifier) 20 mA
 - I_{DD} (LO amplifier) 10 mA
 - I_{DD} (mixer, IF amplifier) 20 mA
- Input power P_{IN} +5 dBm

Operating Condition

- Supply voltage 3.0 V



Electrical Characteristics

$V_{DD}=3.0\text{ V}$, $f_{RF}=1.49\text{ GHz}$, $f_{LO}=1.62\text{ GHz}$, $P_{LO}=-15\text{ dBm}$, when $50\ \Omega$ I/O matching; unless otherwise specified
($T_a=25\text{ }^\circ\text{C}$)

	Item	Symbol	Min.	Typ.	Max.	Unit	Measurement condition
Low noise amplifier	Current consumption	I_{DD}	—	2.2	3.0	mA	When no signal
	Power gain	G_P	14	16	18	dB	
	Noise figure	NF	—	1.85	2.6	dB	
	Input IP3	IIP3	-7.5	-3.5	—	dBm	
	Isolation	Iso	30	35	—	dB	
Mixer	Current consumption	I_{DD}	—	3.8	5.5	mA	When no signal
	Conversion gain	G_c	6	8	10	dB	
	Noise figure	NF	—	8.5	10.5	dB	
	Input IP3	IIP3	-2	2	—	dBm	
	LO to RF leak level	PLK	—	-17	-12	dBm	

Block Diagram

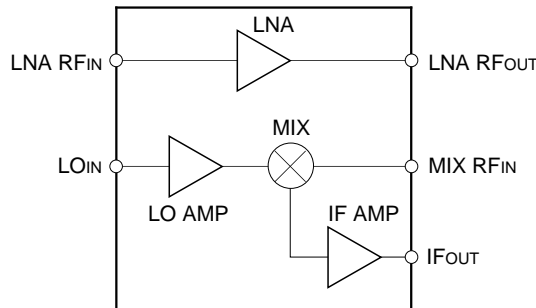

Pin Configuration

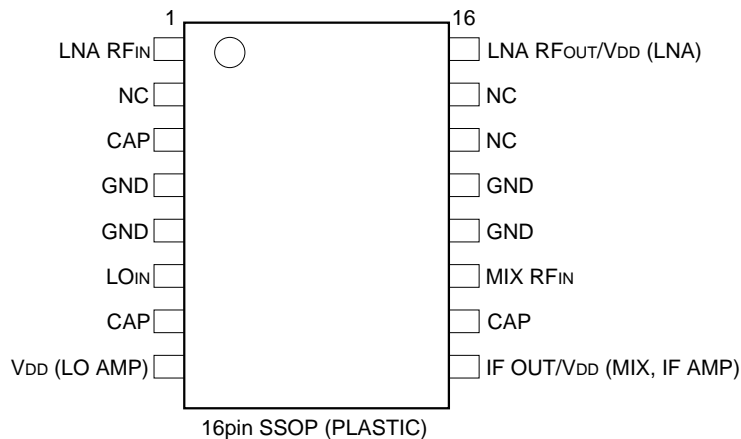

Recommended Circuit

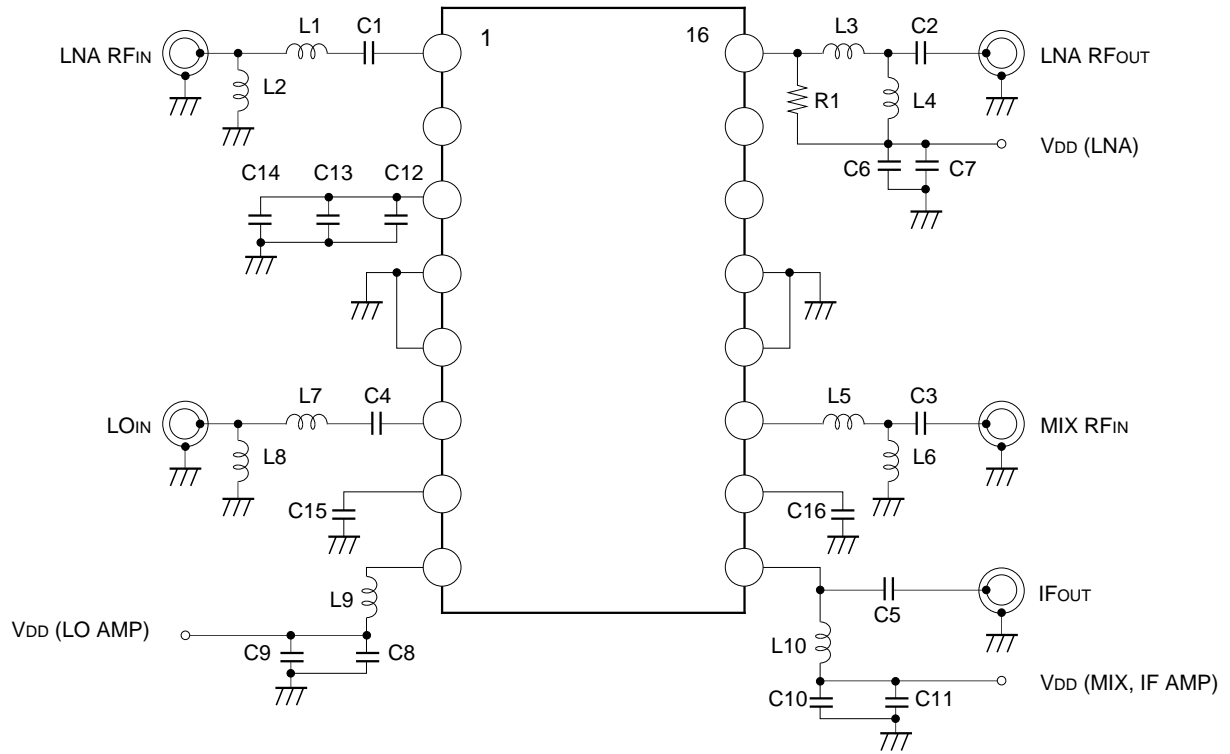

L1	6.8 nH	L10	150 nH	C9	10 nF
L2	4.7 nH	C1	100 pF	C10	1000 pF
L3	4.7 nH	C2	100 pF	C11	1 μF
L4	3.3 nH	C3	2 pF	C12	100 pF
L5	10 nH	C4	100 pF	C13	1000 pF
L6	4.7 nH	C5	10 pF	C14	1 μF
L7	5.6 nH	C6	1000 pF	C15	1000 pF
L8	3.3 nH	C7	1 μF	C16	1 μF
L9	10 nH	C8	1000 pF	R1	1 kΩ

Recommended Evaluation Board

Front

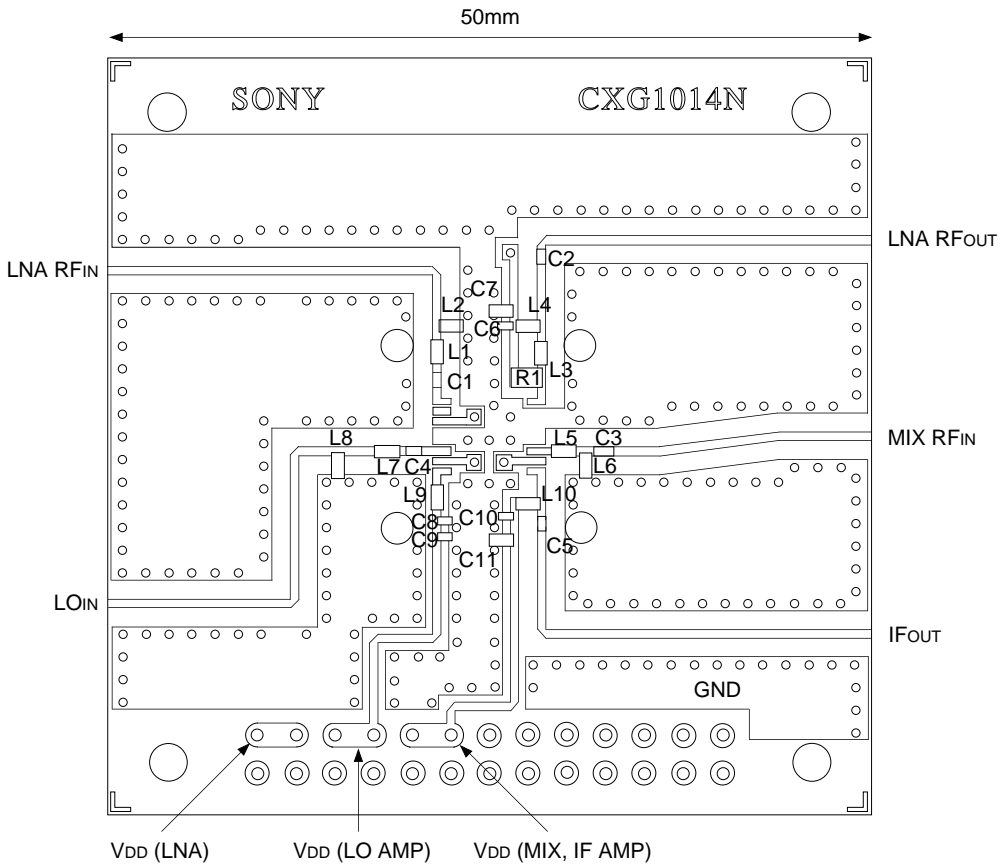

Back

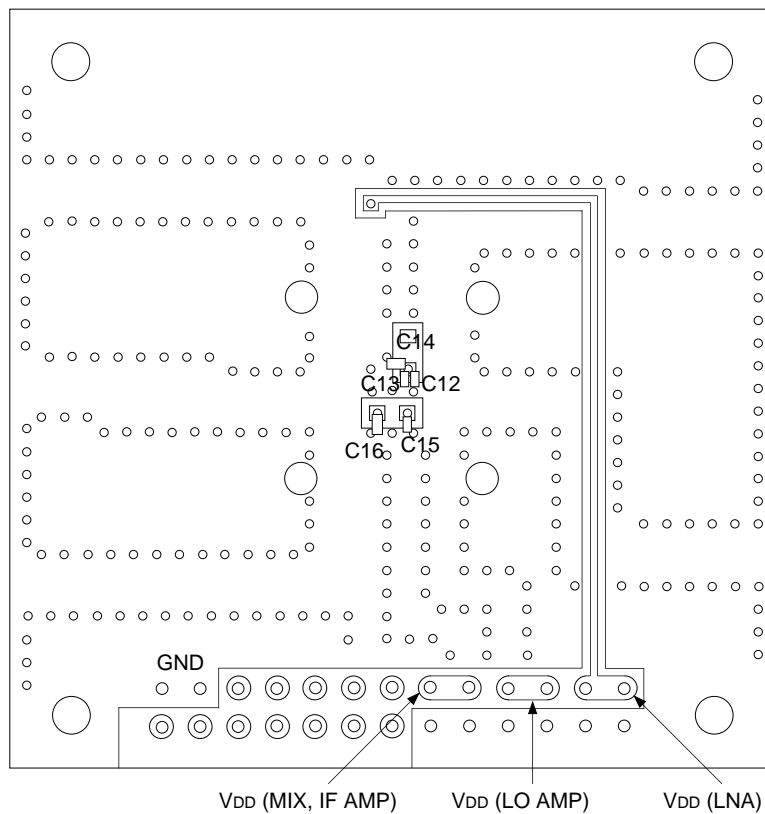

Glass fabric-base epoxy 4-layer board (2 × 0.3 mm thickness)
GND for the 2nd and 3rd layers.

Example of Representative Characteristics (Ta=25 °C)

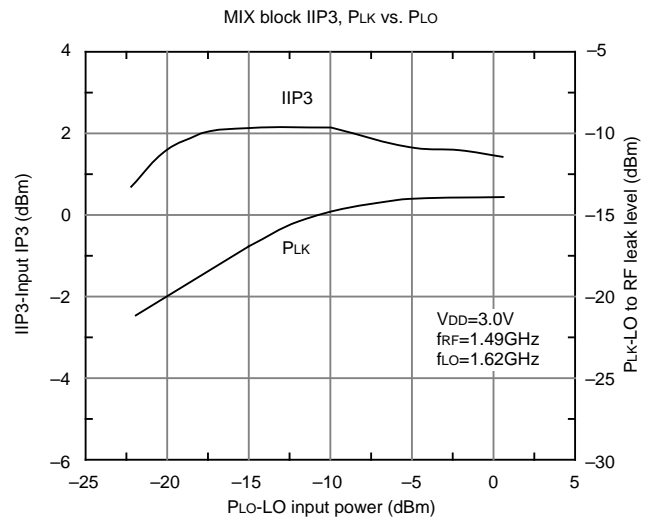
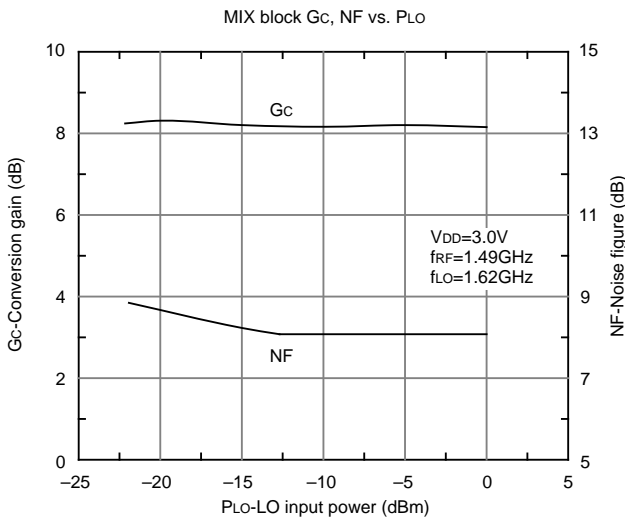
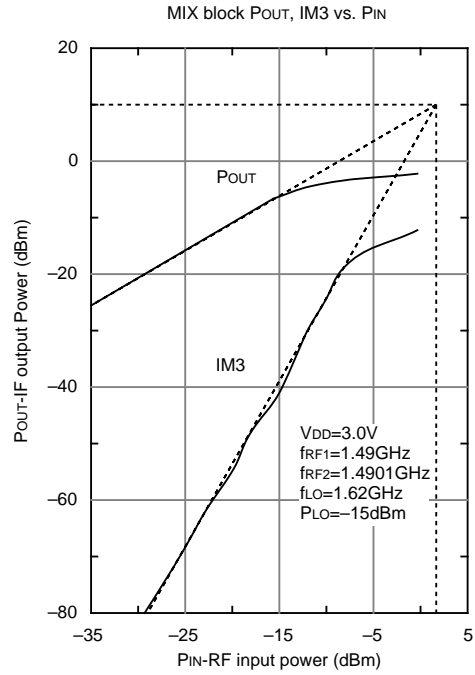
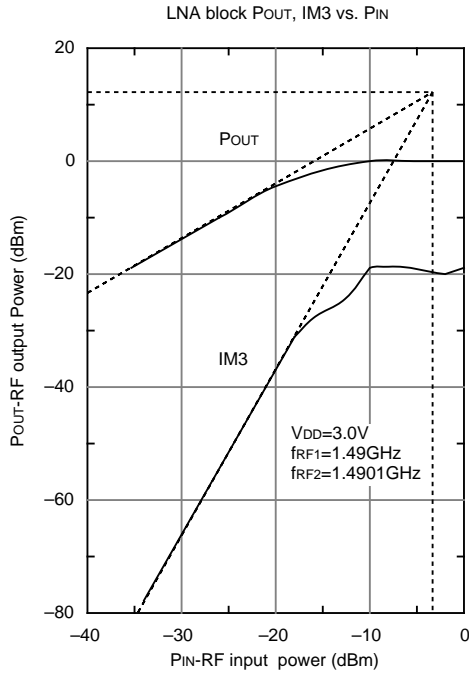

Package Outline Unit : mm

16PIN SSOP (PLASTIC)

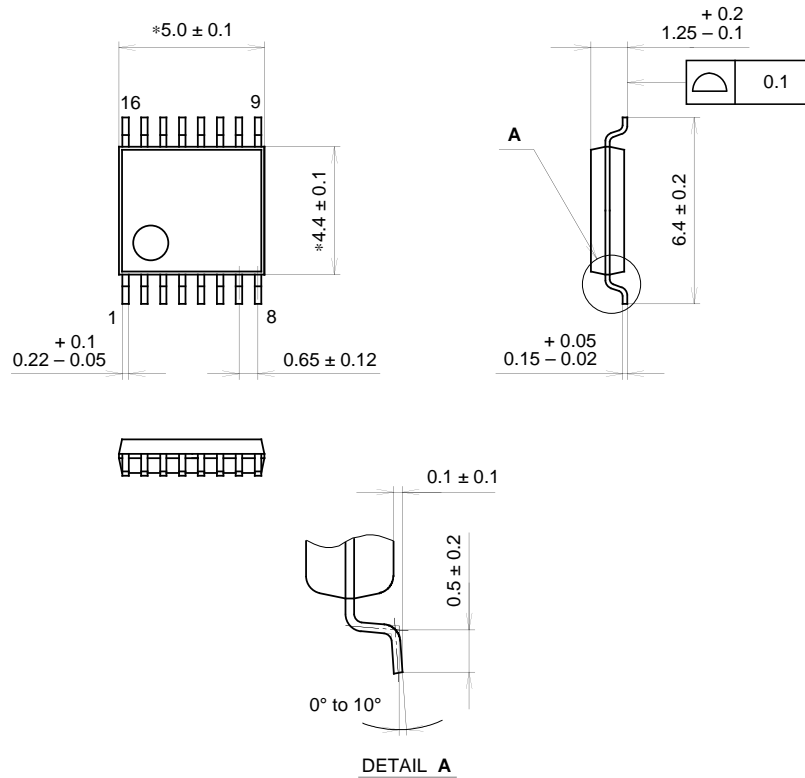

NOTE: Dimension "*" does not include mold protrusion.

PACKAGE STRUCTURE

SONY CODE	SSOP-16P-L01
EIAJ CODE	SSOP016-P-0044
JEDEC CODE	_____

PACKAGE MATERIAL	EPOXY RESIN
LEAD TREATMENT	SOLDER / PALLADIUM PLATING
LEAD MATERIAL	COPPER / 42 ALLOY
PACKAGE WEIGHT	0.1g

NOTE : PALLADIUM PLATING

This product uses S-PdPPF (Sony Spec.-Palladium Pre-Plated Lead Frame).