

SONY

CXG1027TM

Driver Amplifier for Transmission

Description

The CXG1027TM is a two-stage driver amplifier for 800 MHz and 1.5 GHz PDC. This is used to amplify the transmission-side power of the RF signal.

Features

- Ultraminiature package (10 pin TSSOP)
- Low voltage operation
 - : 2.9 V (Min.)
- Low current consumption
 - : 45 mA (Typ.)
- High gain
 - : 27.5 dB (Typ.) (for 1.5 GHz)
 - 29.5 dB (Typ.) (for 800 MHz)
- Low distortion (Adjacent channel leak power ratio)
 - : -50 dBc (Typ.) (30 kHz offset)
 - 69 dBc (Typ.) (50 kHz offset)
- Positive power supply operation (Adjustment-free for V_{GG})
- Supports both 800 MHz and 1.5 GHz by the external matching circuit

Applications

Power amplification between the quadrature modulator IC for 800 MHz/1.5 GHz PDC transmitter (approx. -15 dBm output) and the power module or power amplifier MMIC (approx. +10 dBm input)

Structure

GaAs MMIC

10 pin TSSOP (Plastic)

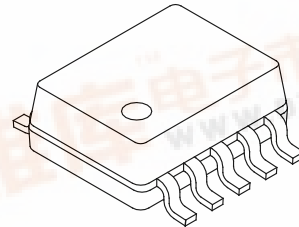

Absolute Maximum Ratings (Ta=25 °C)

- Supply voltage V_{DD} 6 V
- Operating temperature
 - T_{opr} -35 to +85 °C
- Storage temperature
 - T_{stg} -65 to +150 °C
- Allowable power dissipation
 - P_D 550 mW
- Voltage between gate and source
 - V_{GSO} 15 V
- Drain current 150 mA

Operating Condition

- Supply voltage V_{DD} 3.4 V
- V_{GG} 0.2 V



Electrical Characteristics

V_{GG}=0.2 V, V_{DD}=3.4 V, f=941.5 MHz

(Ta=25 °C)

Item	Symbol	Min.	Typ.	Max.	Unit
*1 Current consumption	I _{DD}		45	65	mA
Output power	P _{OUT}	10			dBm
*1 Power gain	G _P	27	29.5	32	dB
*2 Adjacent channel leak power ratio (30 kHz offset)	ACPR30		-50	-47	dBc
*2 Adjacent channel leak power ratio (50 kHz offset)	ACPR50		-69	-65	dBc

V_{GG}=0.2 V, V_{DD}=3.4 V, f=1.441 GHz

(Ta=25 °C)

Item	Symbol	Min.	Typ.	Max.	Unit
*1 Current consumption	I _{DD}		45	65	mA
Output power	P _{OUT}	10			dBm
*1 Power gain	G _P	25	27.5	30	dB
*2 Adjacent channel leak power ratio (30 kHz offset)	ACPR30		-50	-47	dBc
*2 Adjacent channel leak power ratio (50 kHz offset)	ACPR50		-69	-65	dBc

*1 : When +10 dBm output

*2 : When +10 dBm output, 21 kHz band width

Block Diagram

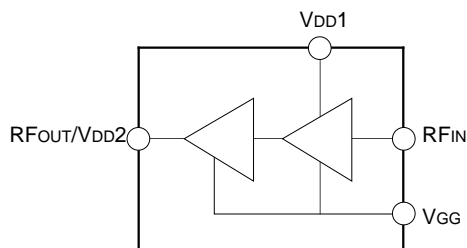

Package Description/Pin Configuration

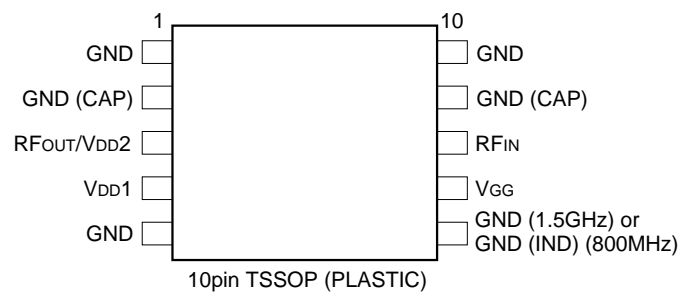

Recommended Circuit

(For 800 MHz)

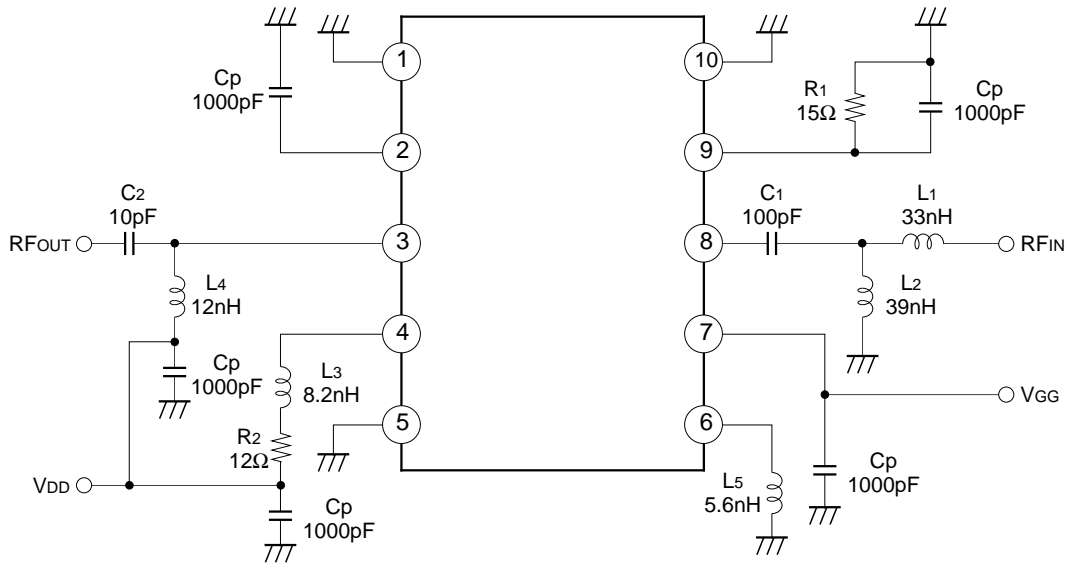

(For 1.5 GHz)

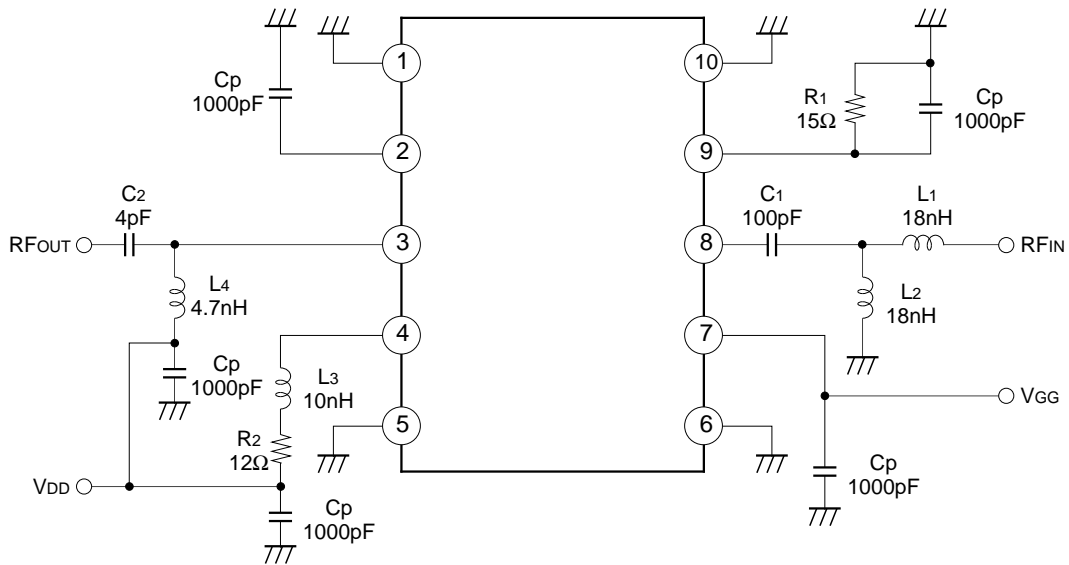

Recommended Evaluation Board

(For 800 MHz)

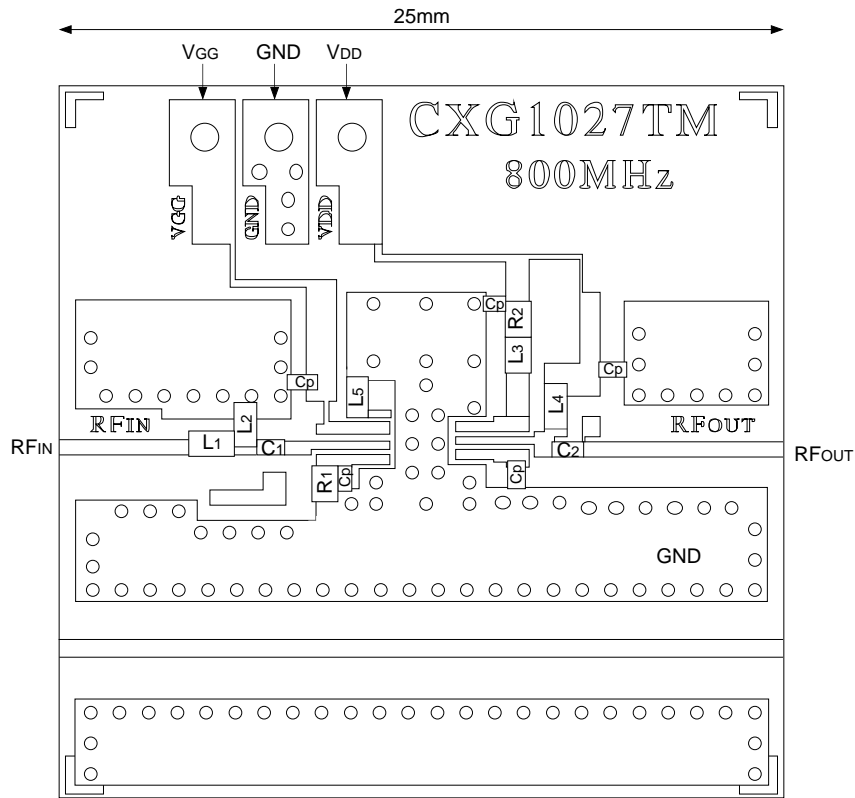

(For 1.5 GHz)

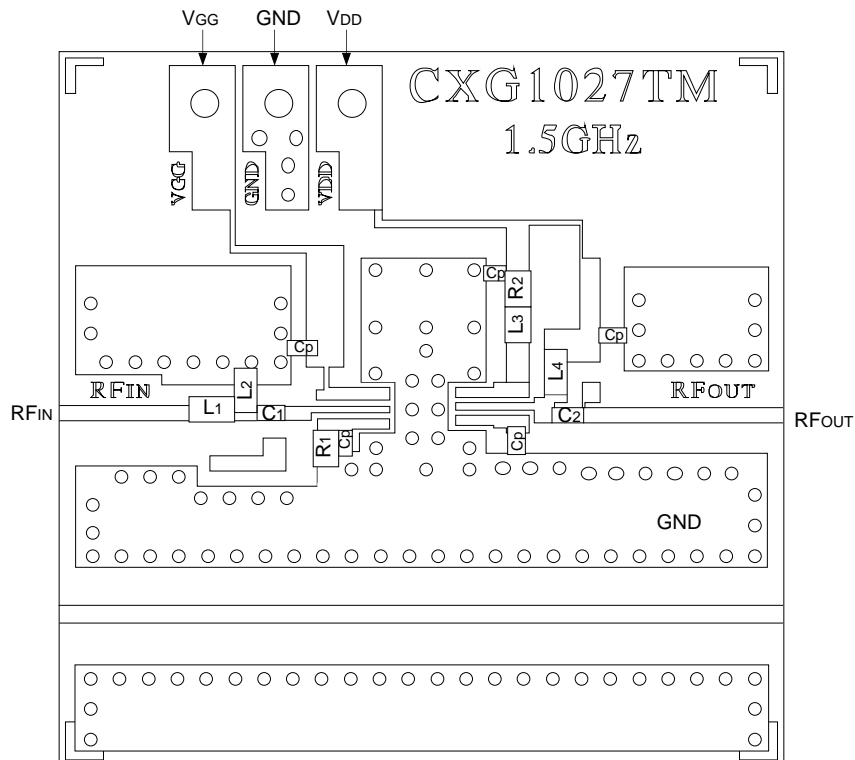

Glass fabric-base epoxy 4-layer board (Thickness : 0.3 mm × 2)
 GND for the overall 2nd, 3rd and 4th sides

Example of Representative Characteristics (Ta=25 °C)

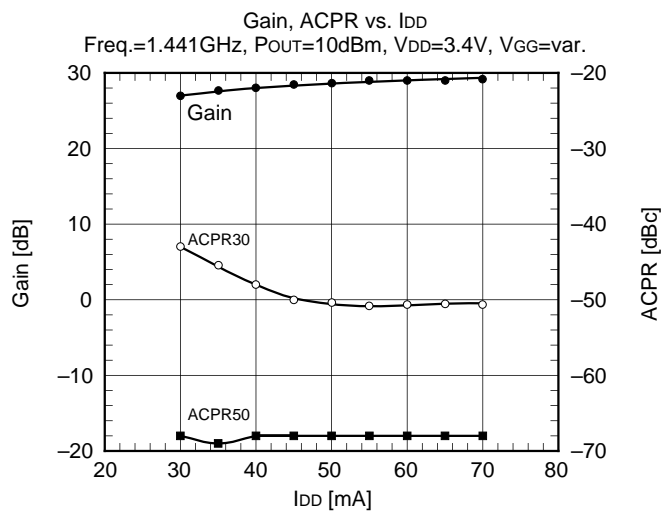
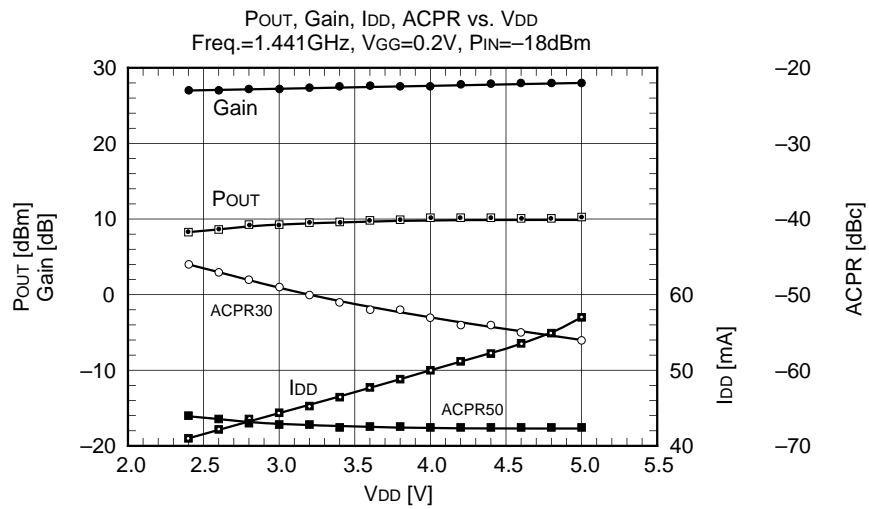
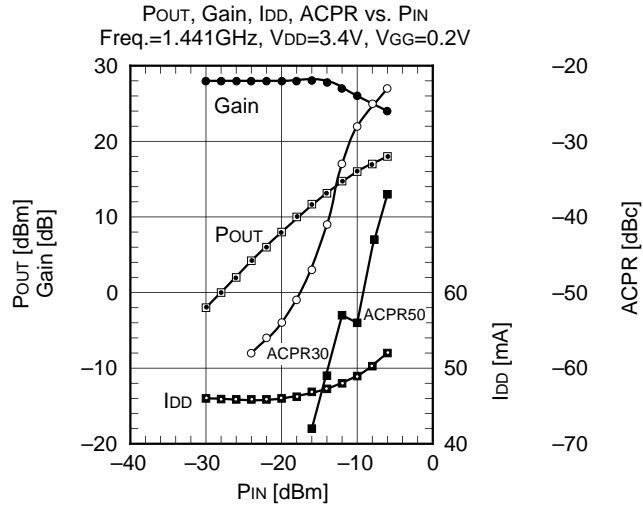

Package Outline Unit : mm

10PIN TSSOP(PLASTIC)

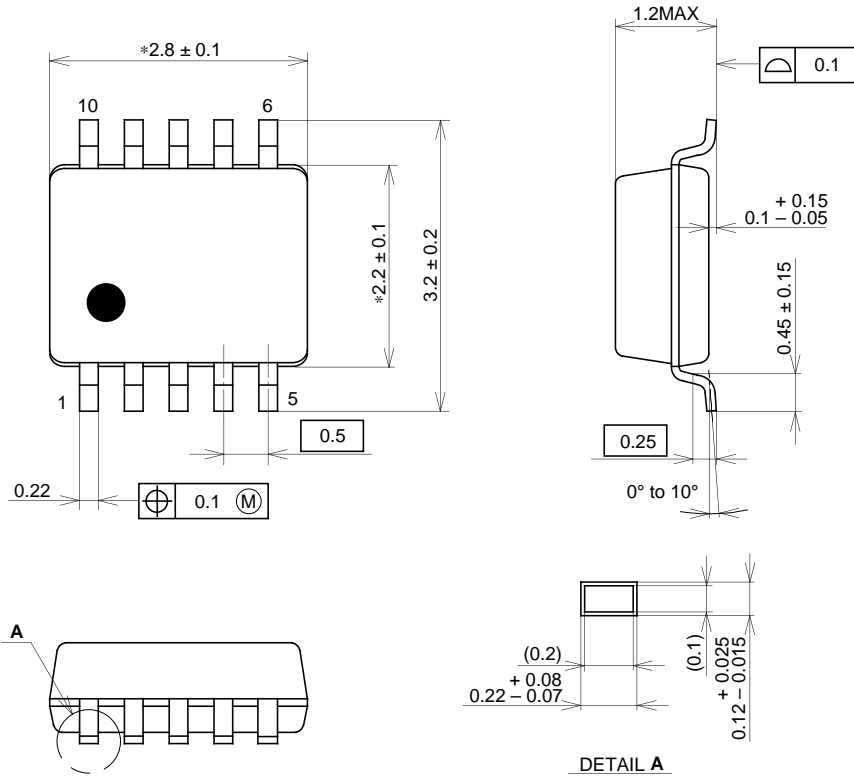

NOTE: "*" Dimensions do not include mold protrusion.

PACKAGE STRUCTURE

SONY CODE	TSSOP-10P-L01
EIAJ CODE	_____
JEDEC CODE	_____

PACKAGE MATERIAL	EPOXY RESIN
LEAD TREATMENT	SOLDER PLATING
LEAD MATERIAL	COPPER ALLOY
PACKAGE MASS	0.02g