

# GSM/UMTS Dual Mode Terminal Ultralow Loss Antenna Switch Module CXG1190EQ/AEQ

Portable telephone terminals are seeing rapid advances in functionality as easily handheld devices.

The third generation cellular phone service is poised to take off on a worldwide scale.

The CXG1190EQ/AEQ are antenna switching modules that support dual mode operation for both GSM, which holds an large share worldwide, and UMTS, which is the third generation cellular phone standard.

In addition to both multiband and multimode support, the CXG1190EQ/AEQ are high-performance lead frame modules that achieve low insertion loss and a miniature low-height form factor.

These modules support the creation of wireless equipment that remains one step ahead using Sony's MMIC technologies.

- Ultralow insertion loss: 0.9 dB in the DCS/PCS Tx path and 0.65 dB in the UMTS (Rx) path
- Dual low-pass filters: Attenuation 30 dB typical (GSM Tx 2fo, DCS/PCS Tx 2fo)
- Lead frame module that adopts a mold array package
- Miniature low-height package: LQFN-28P-01 (4.5 mm × 3.2 mm × 1.3 mm max.)

## Switching Structure that Achieves Low Insertion Loss

Insertion loss is an important index for switch performance.

Switch modules using the conventional LTCC\* substrate adopted a structure in which the frequency band was divided into a low band (900 MHz band) and a high band (1800/1900 MHz band) using a diplexer, and after that, the path switches were connected. (See figure 1.) The switch structure adopted by Sony in these products is the SP7T structure. A low-pass filter is inserted in the GSM Tx path. (See figure 2.) In the conventional LTCC module structure, the insertion loss for all of the paths was the sum of the diplexer and the path switches themselves. As a result, the overall loss was quite large.

In contrast, in the SP7T structure, only the switch insertion loss occurs in the paths

other than the GSM Tx path, thus achieving low loss. For the GSM Tx path, the SP7T + LPF structure can achieve lower loss than the diplexer structure since a LPF has smaller insertion loss than a diplexer. Furthermore, these devices achieve ultralow loss by using Sony's unique JPHEMT process. This contributes significantly to reduced current consumption during Tx and higher Rx sensitivity.

\*: LTCC: Low temperature co-fired ceramic

## Lead Frame Module

Conventional antenna switch modules used in GSM terminals and other products adopt a structure in which passive and active elements, such as PIN diodes, are mounted on an LTCC, FR-4 or similar substrate. However, considering the demands for multimode and multiband operation, miniature low-height form factors, and lower costs in recent cellular phone products, it can easily be seen that it will be difficult to achieve these using these conventional structures. Sony's response to these issues was implemented using the mold array package, which uses lead frames, an existing package technology. By adopting an existing package that uses lead frames, Sony was able to assure the pin count required for the increase in the number of switches due to the use of multimode and multiband operation. Furthermore, this made further miniaturization easy.

Another advantage was that it was possible to keep to an absolute minimum the

number of changes to the assembly process in current manufacturing lines. This contributes to lowering the cost of the devices. Since handling is only required for two simple components, an IC and a low-pass filter, Sony was able to shorten the development turn around time. Also, the adoption of a package with a proven track record in the market has the advantage that customers can use these devices with confidence.

## Miniature Low-Height Form Factor

The mounting area was reduced by making the two low-pass filters integrated in the two Tx paths into one component using LTCC technology. Also, etching technology can be used to perform complicated machining on the lead frame, which plays the role of interface between the internal components. That technology is used for the connections for the internal low-pass filters in these products. Furthermore, Sony optimized the contact area between the internal low-pass filter lands and the lead frame and also optimized the mold sealing thickness above the low-pass filters, thus achieving a miniature low-height form factor.

## V O I C E

The CXG1190EQ/AEQ ICs could only have been developed by Sony, and were developed from Sony's unique perspective, a perspective unknown at other companies. These devices are already earning an enthusiastic response in the market. We are now planning new products that deploy this technology. Keep your eye on Sony's MMIC technologies!



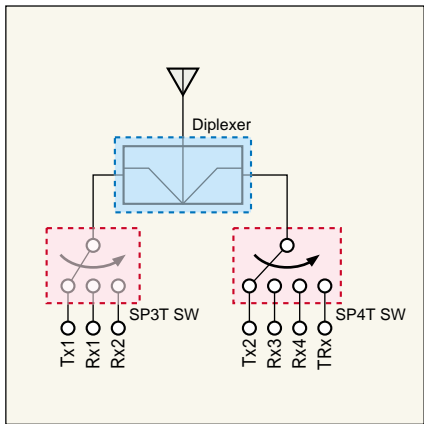

■ Figure 1 Conventional Antenna Switch Module Block Diagram

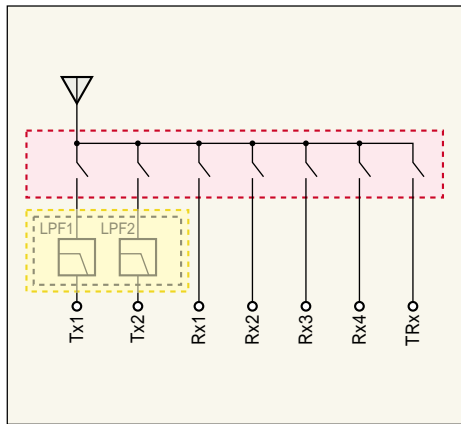

■ Figure 2 CXG1190EQ Block Diagram

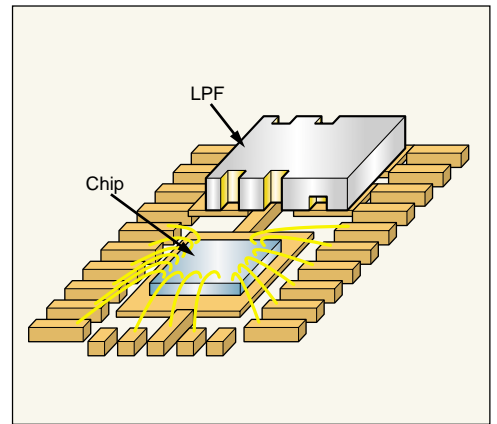

■ Figure 3 Internal Structures Drawing

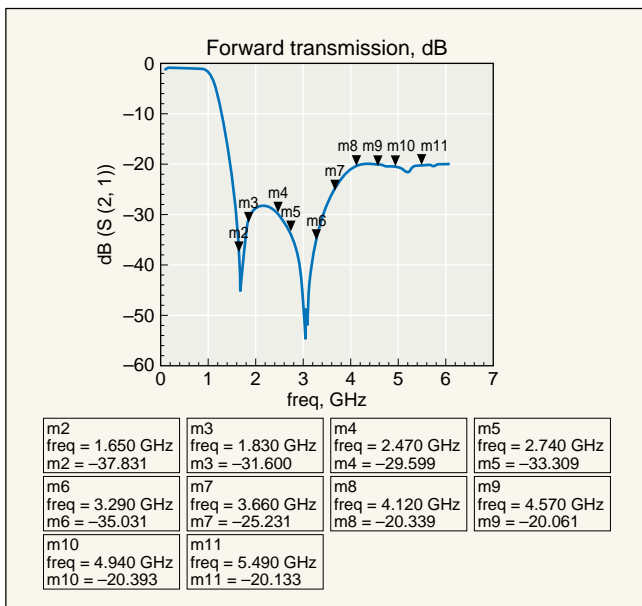

■ Figure 4 Low-Band Low-Pass Filter Attenuation Characteristics

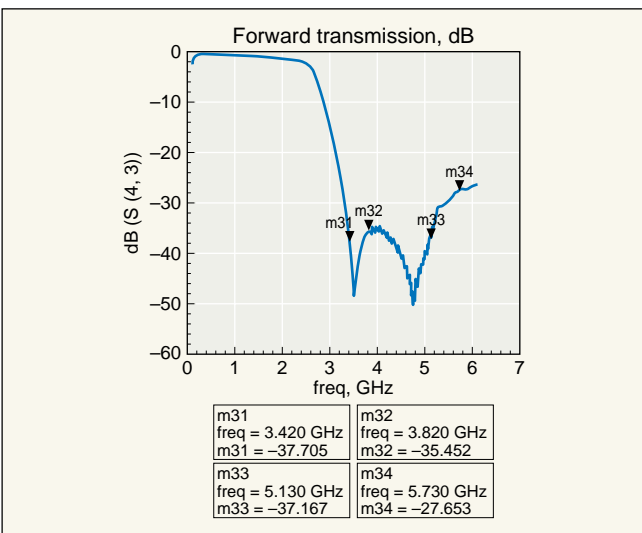

■ Figure 5 High-Band Low-Pass Filter Attenuation Characteristics

■ Table 1 Insertion Loss

Path	Condition	Insertion Loss (I.L.)			Unit
		Min.	Typ.	Max.	
Tx1 – Ant	*1	—	0.85	1.20	dB
Tx2 – Ant	*2	—	0.90	1.25	
TRx (Tx) – Ant	*3	—	0.60	0.90	
Ant – Rx1	*4/*5	—	0.75/0.90	1.05/1.20	
Ant – Rx2	*4/*5	—	0.75/0.90	1.05/1.20	
Ant – Rx3	*4/*5	—	0.75/0.90	1.05/1.20	
Ant – Rx4	*4/*5	—	0.75/0.90	1.05/1.20	
Ant – TRx (Rx)	*6	—	0.65	0.95	

\*1: Frequency = 824–849, 880–915 MHz, Input Signal is CW, Pin = +34 dBm

\*2: Frequency = 1710–1785, 1850–1910 MHz, Input Signal is CW, Pin = +32 dBm

\*3: Frequency = 1920–1980 MHz, Input Signal is CW, Pin = +29 dBm

\*4: Frequency = 869–894, 925–960 MHz, Input Signal is CW, Pin = -5 dBm

\*5: Frequency = 1805–1880, 1930–1990 MHz, Input Signal is CW, Pin = -5 dBm

\*6: Frequency = 2110–2170 MHz, Input Signal is CW, Pin = -5 dBm

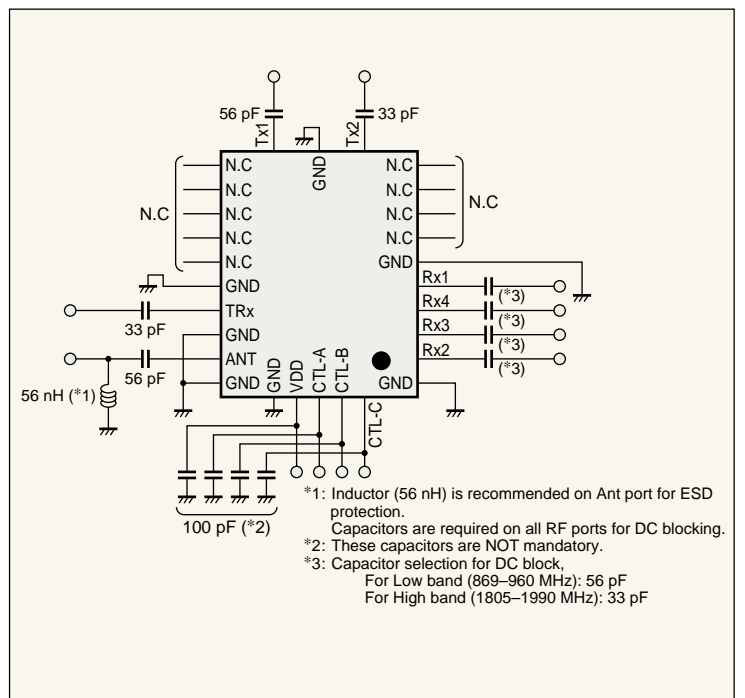

■ Figure 6 Application Circuit Example