

SONY

CXL5001M/P

CMOS-CCD 1H Delay Line for NTSC

Description

The CXL5001M/P are general-purpose CMOS-CCD delay line ICs that provide 1H delay time for NTSC.

Features

- Low power consumption 80mW (Typ.)
- Small size package (8-pin SOP, DIP)
- Low differential gain DG = 3% (Typ.)
- Input signal amplitude 180 IRE (= 1.28Vp-p, Max.)
- Low input clock amplitude operation 150mVp-p (Min.)
- Built-in peripheral circuits (clock driver, timing generator, autobias, and output circuits)

Functions

- 680-bit CCD register
- Clock drivers
- Autobias circuit
- Sync tip clamp circuit
- Sample and hold circuit

Structure

CMOS-CCD

Absolute Maximum Ratings (Ta = 25°C)

• Supply voltage	V _{DD}	11	V
• Supply voltage	V _{CL}	6	V
• Operating temperature	T _{opr}	-10 to +60	°C
• Storage temperature	T _{stg}	-55 to +150	°C
• Allowable power dissipation	P _D		
		CXL5001M	350 mW
		CXL5001P	480 mW

Recommended Operating Conditions

Supply voltage	V _{DD}	9 ± 5%	V
	V _{CL}	5 ± 5%	V

Recommended Clock Conditions

- Input clock amplitude V_{CLK} 150mVp-p to 1.0Vp-p (250mVp-p typ.)
- Clock frequency f_{CLK} 10.7MHz

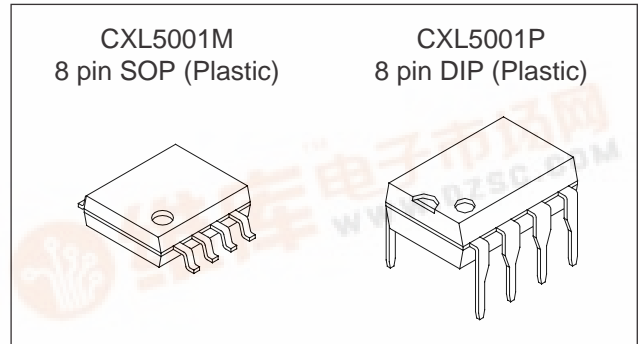

Block Diagram

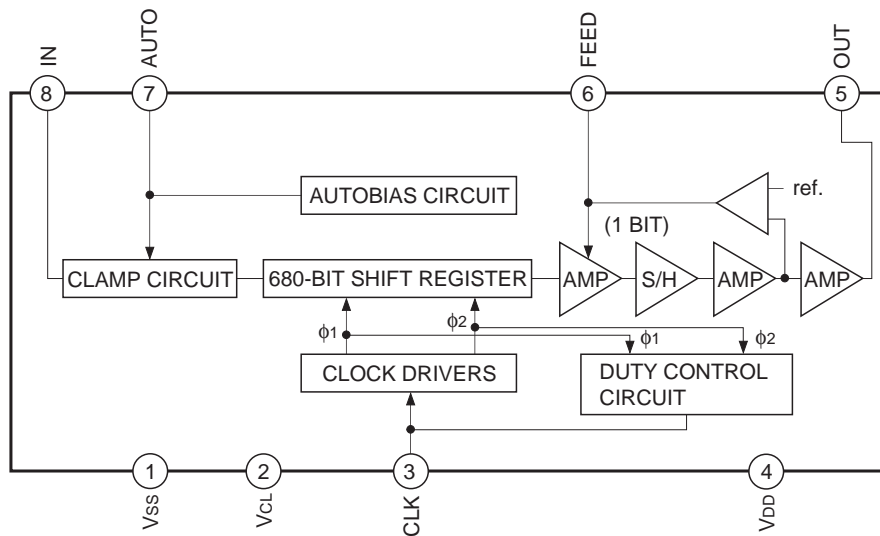

Pin Description

Pin No.	Symbol	Description	Impedance [Ω]	Pin No.	Symbol	Description	Impedance [Ω]
1	V _{SS}	GND		5	OUT	Signal output	600 to 1k
2	V _{CK}	5V power supply		6	FEED	Feedback DC output	> 100k
3	CLK	Clock input	> 100k	7	AUTO	Autobias DC output	10k
4	V _{DD}	9V power supply		8	IN	Signal input	> 100k

Electrical Characteristics

($T_a = 25^\circ\text{C}$, $V_{DD} = 9.0\text{V}$, $V_{CL} = 5.0\text{V}$, $f_{CLK} = 10.7\text{MHz}$, $V_{CLK} = 250\text{mVp-p}$ sine wave,
See "Electrical characteristics measuring circuit")

Item	Symbol	Measuring condition	SW conditions		Measuring point	Min.	Typ.	Max.	Unit
			1	2					
Supply current	I _{DD}	250kHz, 1.28Vp-p, sine wave input	a	a	A1	—	4	5	mA
	I _{CL}				A2	—	9	11	mA
Insertion gain	IG	250kHz, 1.28Vp-p, sine wave input IG = 20 log (Output voltage [Vp-p] / 1.28 [Vp-p])	a	a	V1	-3	0	3	dB
Frequency response	fG	Dissipation at 3.5MHz in relation to 250kHz fG = 20 log (V _{3.5MHz} / V _{250kHz}) (Note 1)	b, c	b	V1	-3.0	-2.1	—	dB
Differential gain	DG	5-staircase wave input Y = 140 IRE (=1.0Vp-p) Measure S point with vector scope (Note 2)	e	a	S	—	3	5	%
Differential phase	DP					—	3	5	deg
Allowable input amplitude	V _{IN-AC}		—	—	—	—	—	1.28	Vp-p
Noise	S/N	S: Input = 250kHz, 1.0Vp-p output (Vp-p)	f	a	V2	55	60	—	dB
		N: Input = DC ground output (mVrms)	d	a	V2				
Output DC voltage	V _{IN-AC}		d	a	V3	3.5	5.0	6.5	V
	V _{AUTO-DC}				V4	3.5	5.0	6.5	V
	V _{FEED-DC}	250kHz, 1.28Vp-p, sine wave input	a	a	V5	1.3	2.3	3.3	V
	V _{OUT-DC}				V6	1.7	2.7	3.7	V

Electrical Characteristics Measuring Circuit

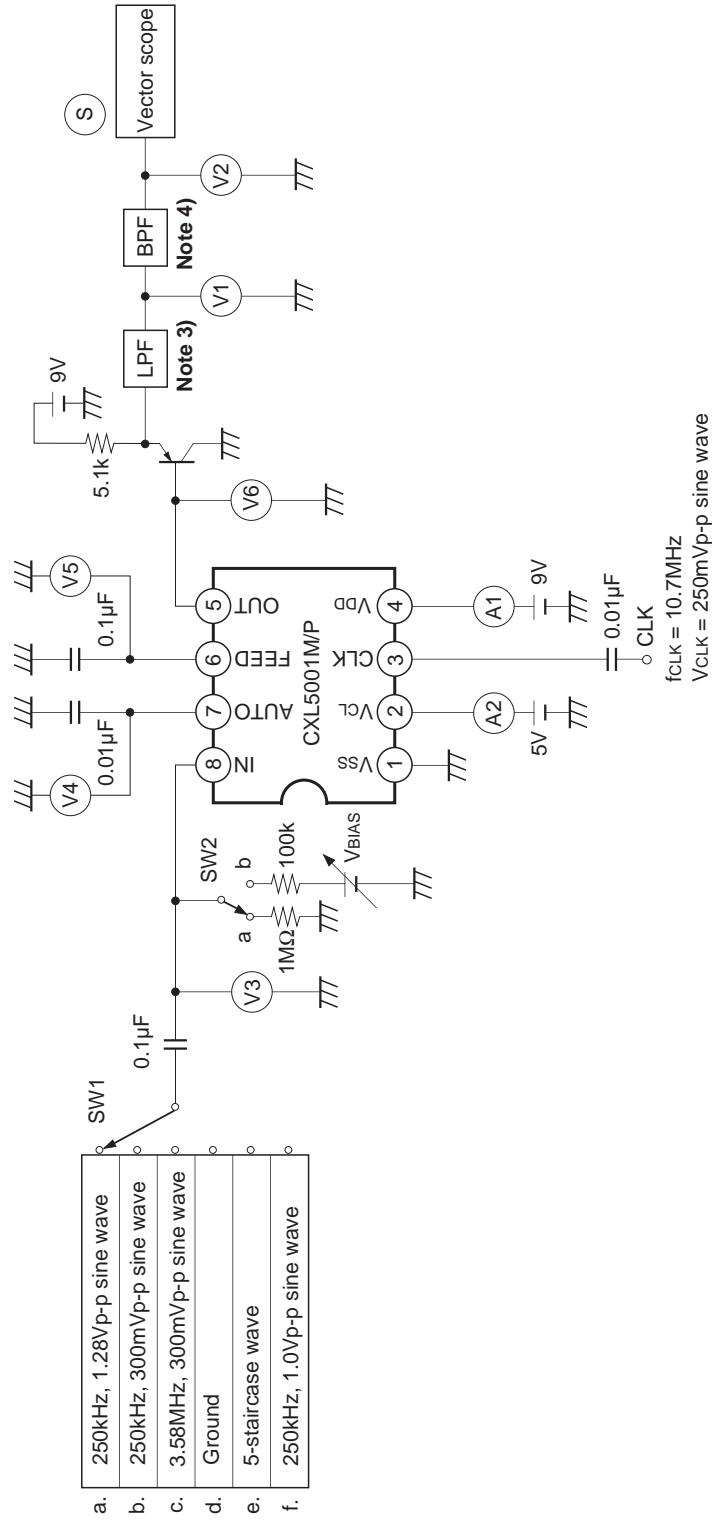

Note 1) Frequency response measuring condition

$V_{3.58\text{MHz}}$ (Output signal voltage [Vp-p] at 3.58MHz input)

$V_{250\text{kHz}}$ (Output signal voltage [Vp-p] at 250kHz input)

Set Pin 8 (IN) voltage [V] = $V_{\text{IN-DC}} + 640\text{mV}$.

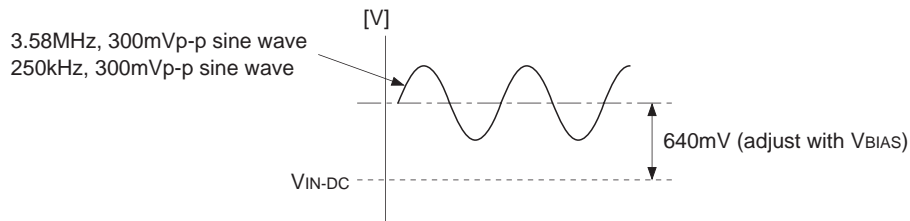

Note 2) Differential gain and differential phase measuring condition

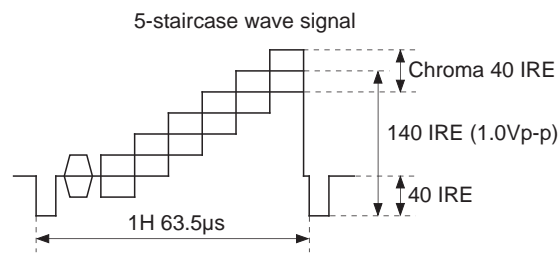

DG and DP are measured at output S point by vector scope.

Note 3) LPF frequency response

(Delay time $\approx 140\text{ns}$)

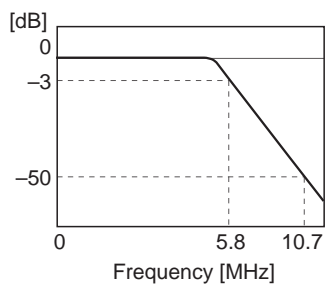

Note 4) BPF frequency response

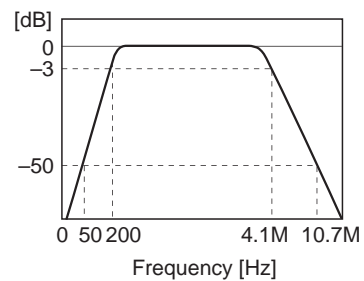

Application Circuit

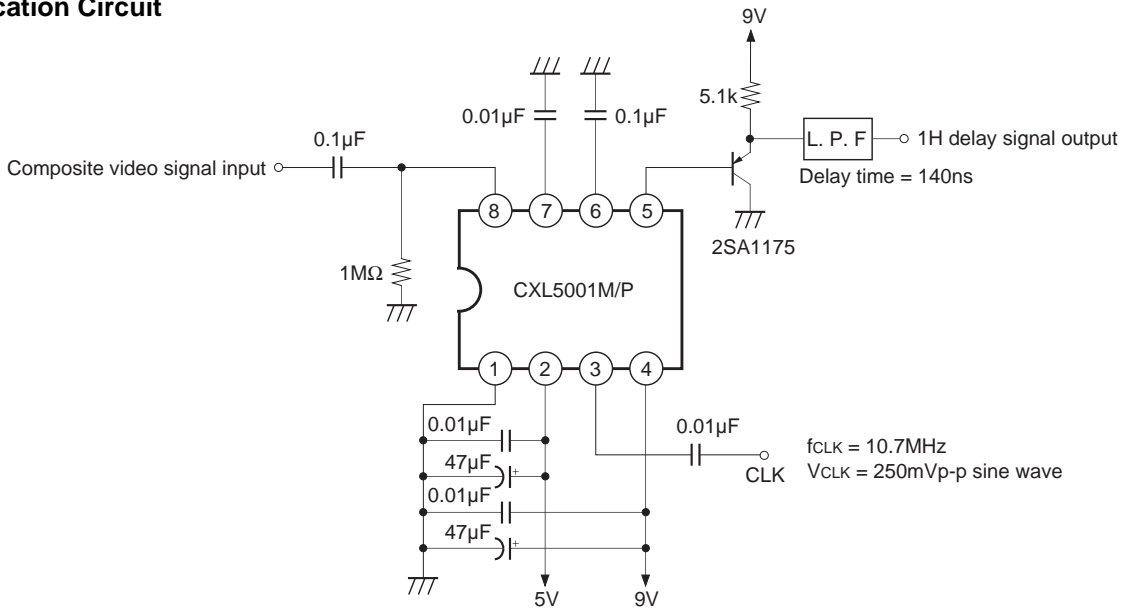

Application circuits shown are typical examples illustrating the operation of the devices. Sony cannot assume responsibility for any problems arising out of the use of these circuits or for any infringement of third party patent and other right due to same.

Example of Representative Characteristics

Frequency response vs. Ambient temperature

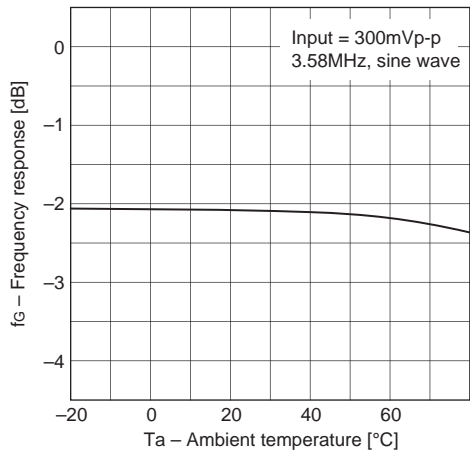

Frequency response vs. Supply voltage

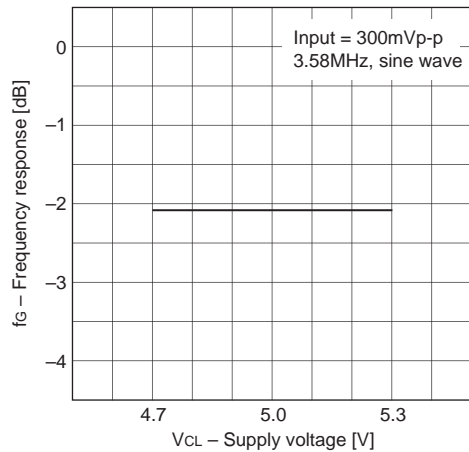

Frequency response vs. Supply voltage

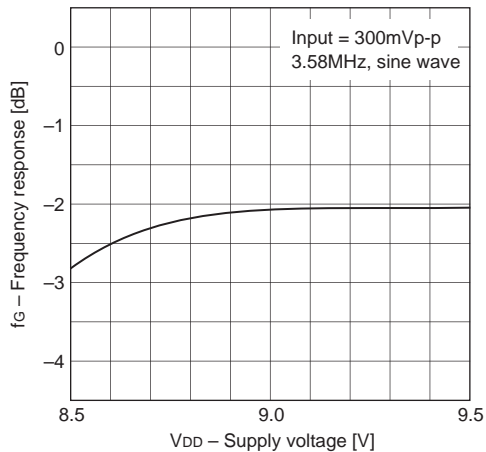

Insertion gain vs. Ambient temperature

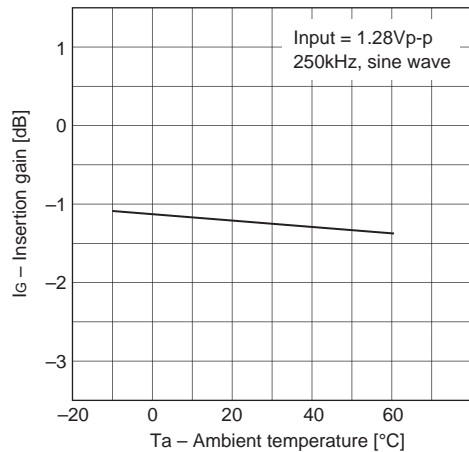

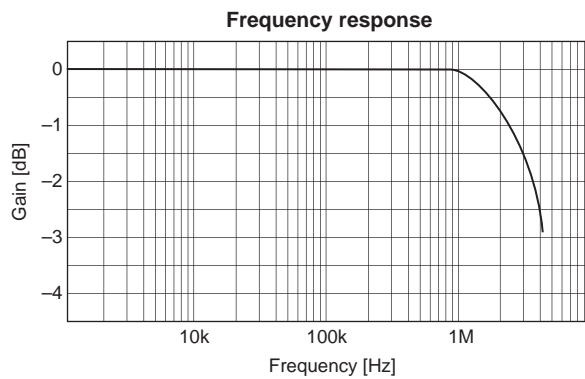
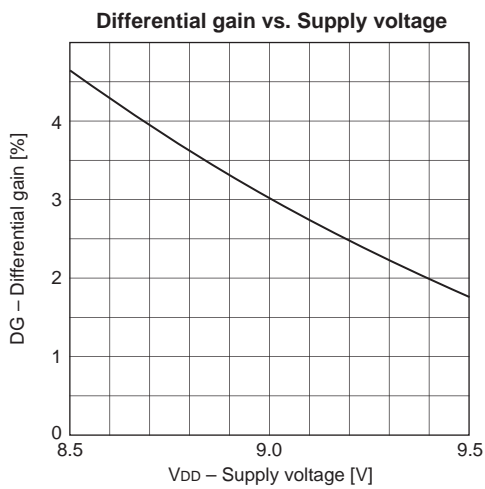
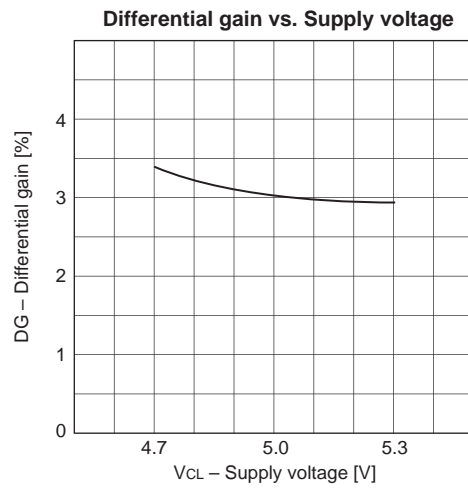
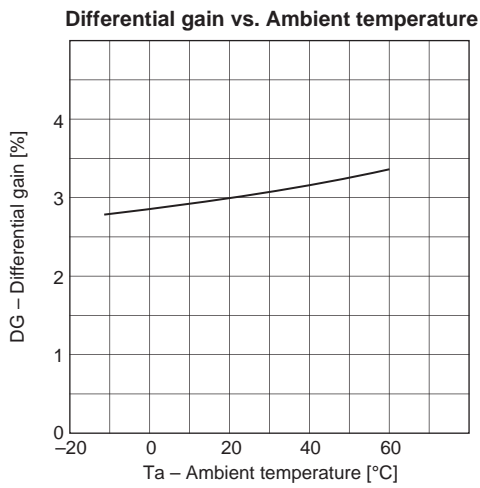
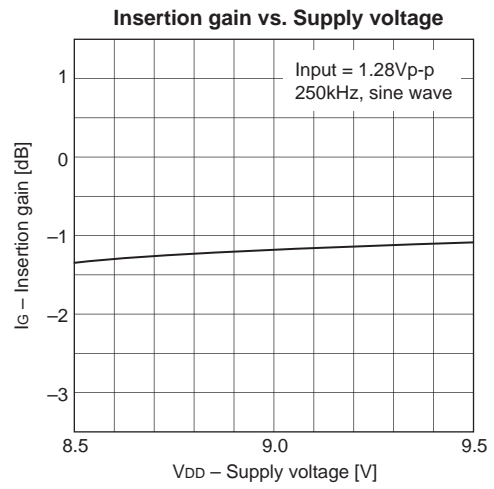
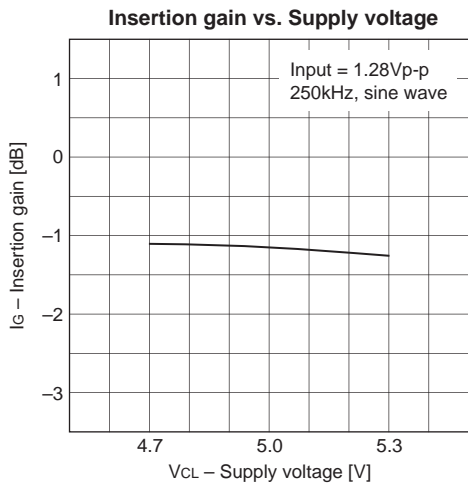

Package Outline Unit: mm

CXL5001M

8PIN SOP (PLASTIC)

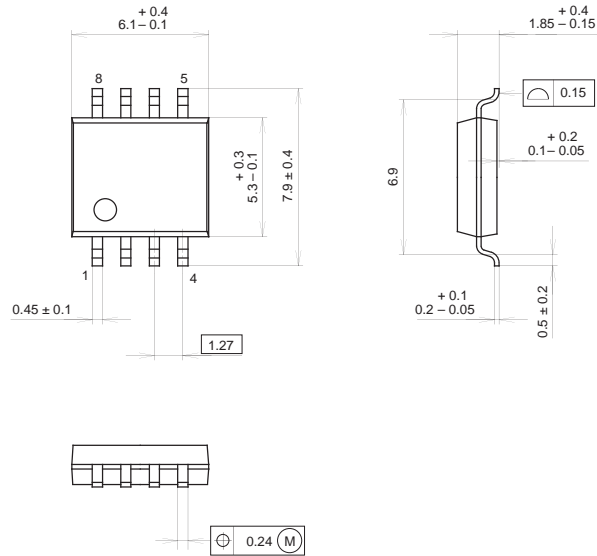

PACKAGE STRUCTURE

SONY CODE	SOP-8P-L01
EIAJ CODE	SOP008-P-0300
JEDEC CODE	

PACKAGE MATERIAL	EPOXY RESIN
LEAD TREATMENT	SOLDER PLATING
LEAD MATERIAL	42/COPPER ALLOY
PACKAGE MASS	0.1g

CXL5001P

8PIN DIP (PLASTIC)

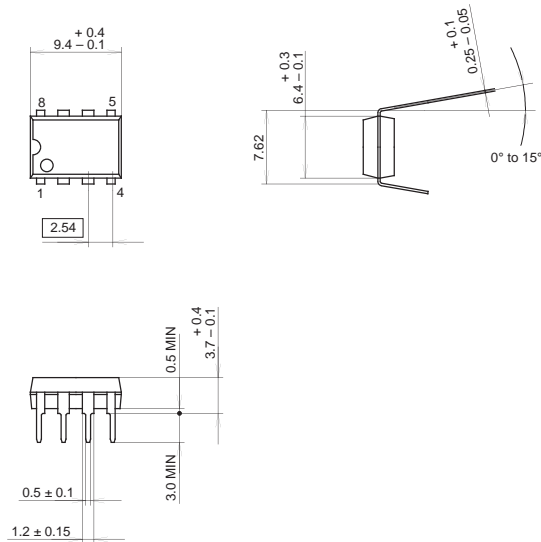

PACKAGE STRUCTURE

SONY CODE	DIP-8P-01
EIAJ CODE	DIP008-P-0300
JEDEC CODE	

PACKAGE MATERIAL	EPOXY RESIN
LEAD TREATMENT	SOLDER PLATING
LEAD MATERIAL	COPPER ALLOY
PACKAGE MASS	0.5g