

**SONY**<sup>®</sup>

**CXP50712/50716**

**CMOS 4-bit Single Chip Microcomputer**

**Description**

The CXP50712/50716 is a CMOS 4-bit microcomputer which consists of 4-bit CPU, ROM, RAM, I/O port, 8-bit timer, 8-bit timer/counter, 18-bit time base timer, 8-bit serial I/O, vector interruption, power on reset function, a liquid crystal display (LCD) controller/driver, remote control receiving circuit with noise eliminating circuit, 3-bit A/D converter, 32kHz timer/event counter, power supply voltage detection reset function and 14-bit PWM output port for D/A conversion. They are integrated into a single chip with the standby function etc. which are to be operated at low power consumption.

**Features**

- Instruction cycle 1.9  $\mu$ s/4.19MHz  
122  $\mu$ s/32kHz  
(Selectable by program)
- ROM capacity 16384  $\times$  8 bits (CXP50716)  
12288  $\times$  8 bits (CXP50712)
- RAM capacity 544  $\times$  4 bits  
(Stack area not included)  
(32  $\times$  4 bits is used in combination with the LCD display memory)
- 43 general purpose I/O ports  
(When all combined ports are used as ports)
- LCD controller/driver(Direct drive possible)
  - 16 to 32 segment outputs selectable through program
  - 1/2, 1/3, 1/4 duty static selectable through program
  - 1/2, 1/3 bias selectable through program



- 14-bit PWM output for D/A conversion
- Remote control receiving circuit
- 3-bit A/D converter (8 channels)
- 32kHz timer/event counter
- Power supply voltage detection reset circuit
- Low voltage operation (2.5V)  
... during 122  $\mu$ s/32kHz operation
- 8 large current output ports
- Rich wake up function
- 8-bit timer, 8-bit timer/event counter, 18-bit time base timer
- 8-bit/4-bit variable serial I/O
- 2 types of power down modes, sleep and stop
- Power on reset circuit (Mask option)
- 80-pin plastic flat package and piggy back package (CXP50700) available

**Structure**

Silicon gate CMOS IC



Block Diagram

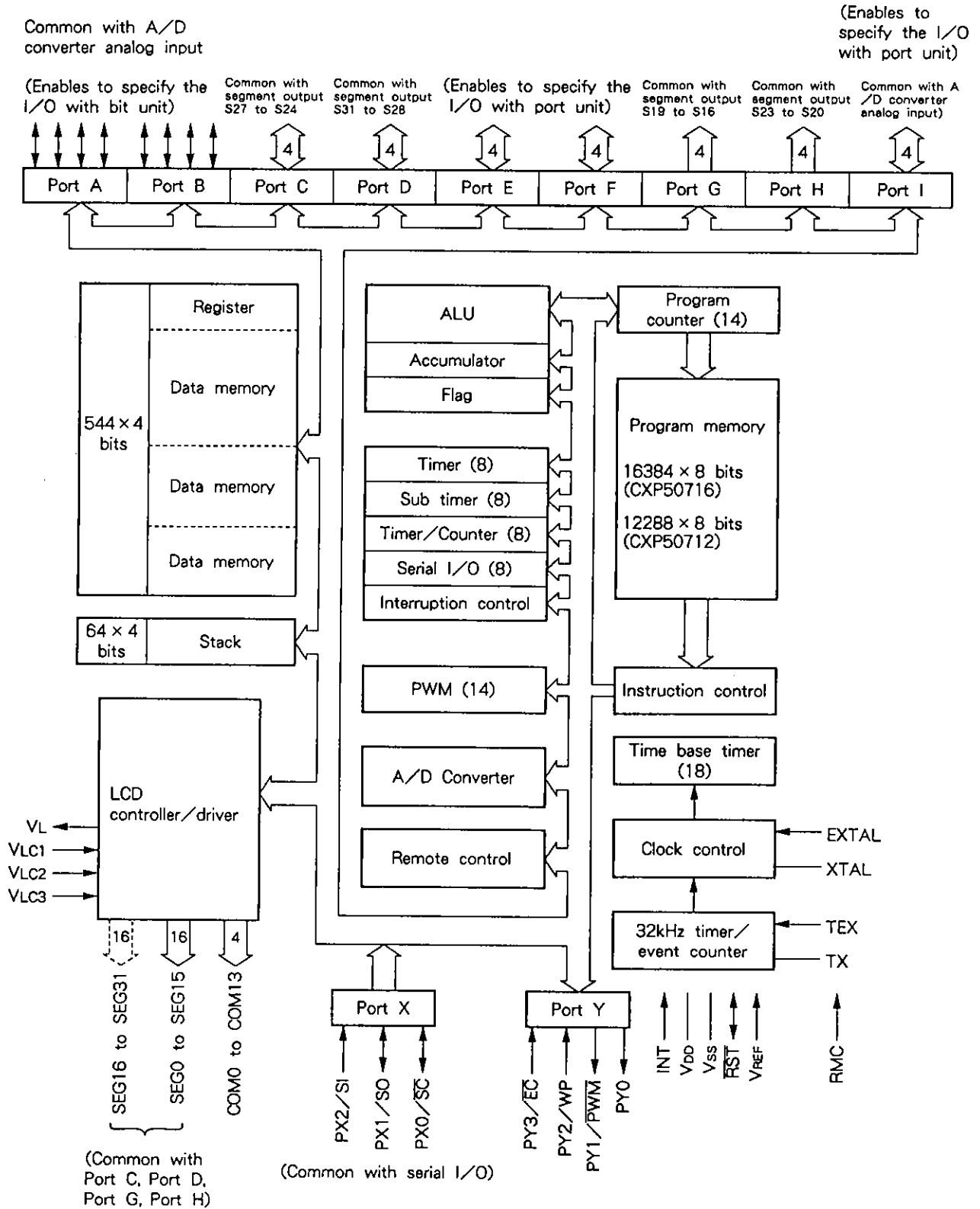

Pin Configuration (Top View)

Note) Do not make any connections to NC pins.

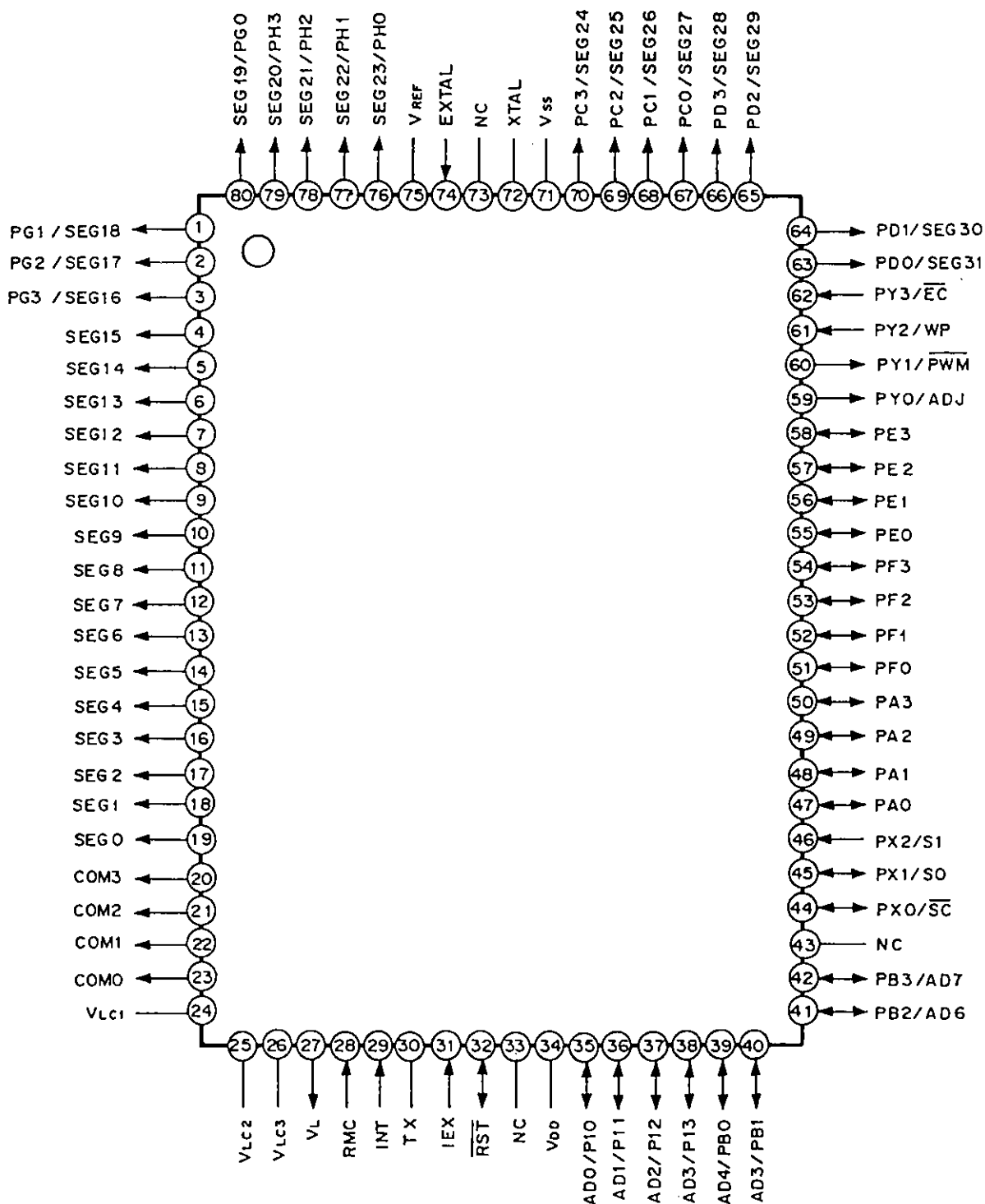

Pin Description

Symbol	Name	I/O	Description	Equivalent Circuit
V <sub>DD</sub>	Supply voltage	I	Positive voltage supply pin	
V <sub>SS</sub>	Grounding voltage	I	GND pin	
EXTAL	Clock input	I	Clock generated circuit input pin. Connect the crystal oscillator or ceramic resonator between the EXTAL and XTAL. To use an external clock input, connect the clock oscillation source to the EXTAL pin and open the XTAL pin.	
XTAL	Clock output	O	Clock generated circuit output pin	
$\overline{\text{RST}}$	Reset	I/O	Serves as the incorporated power-on reset circuit output pin. When inputting a reset signal from the outside, provide 2 instruction cycles or longer of an "L" level (0V).	<p>Mask option</p> <p>Output pull-up resistor (P-ch Tr) N-ch Tr output Schmitt inverter input</p>
INT	External interrupt	I	Serves as interrupt input pin. Permits the selection with a program of the edge and the level modes.	
RMC	Remote control input	I	Remote control receiver input pin	
PX2/SI	Port X2/ Serial input	I	Doubles as a serial interface (8 bits) input pin and as bit "2" (input) of port X.	Schmitt inverter input
PX1/SO	Port X1/ Serial output	I/O	Doubles as a serial data output pin of serial I/O and as bit "1" (input) of port X. (SO output possible to inhibit with the program.)	<p>See Note 2) for the output circuit format. Inverter input</p>

Symbol	Name	I/O	Description	Equivalent Circuit
PX0/SC	Port X0/ Serial clock	I/O	Doubles as shift clock input/output pin for the serial I/O and as bit "0" (input) of port X.	<p>See Note 2) for the output circuit format. Schmitt inverter input</p>
PY3/EC	Port Y3/ Event count input	I	Doubles as event counter (8 bits) input pin and as bit "3" (input) of port Y.	<p>Schmitt inverter input</p>
PY2/WP	Port Y2/ Wake-up input	I	Doubles as wake-up input pin to reset the standby state and as bit "2" (input) of port Y.	
PY1/PWM	Port Y1/ PWM generator output	O	Doubles as PWM generator (14 bits) output pin and as bit "1" (output) of port Y.	<p>See Note 1) for the output circuit format.</p>
PY0/ADJ	Port Y0/ Frequency adjust	O	Doubles as output pin for bit "0" of port Y and 32kHz T/C prescaler output	See Note 1) for the output circuit format.
PA0 to PA3	Port A	I/O	This 4-bit input/output port permits its each individual bit to be programmed to serve either as input or output. For the output format, a tri-state and pull-up resistor possible to be programmed, and it is also used as the standby resetting pin.	<p>See Note 2) for the output circuit format. Inverter input</p>
PB0/AD4 to PB3/AD7	Port B/ Analog voltage input	I/O	This 4-bit input/output port has the functions that are equivalent to those of port A. It is also used for A/D converter input.	
PE0 to PE3	Port E	I/O	This 4-bit input/output port permits its each individual port to be programmed to serve either as input or output. For the output format, a tri-state and pull-up resistor possible to be programmed.	
PF0 to PF3	Port F	I/O	This 4-bit input/output port has the functions that are equivalent to those of port E.	
PI0/AD0 to PI3/AD3	Port I/ Analog voltage input	I/O	This 4-bit input/output port has the functions that are equivalent to those of port E. It is also used for A/D converter input.	

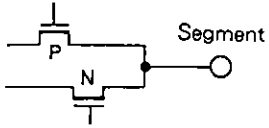
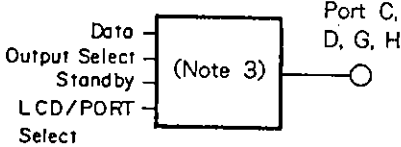
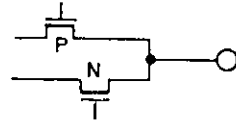
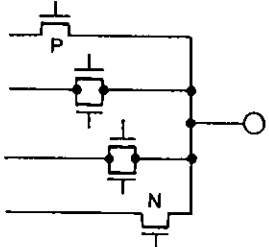
Symbol	Name	I/O	Description	Equivalent Circuit
PD3/ SEG31 to PD0/ SEG28	Port D/ Segment output	O	Doubles as a 4-bit output port (For the output format, the inverter and pull-up resistor possible to be programmed.) and as the segment signal output pin for LCD.	 <p>The transfer gate input signal is controlled based on 1/2, 1/3 bias methods in advance.</p>
PC3/ SEG27 to PC0/ SEG24	Port C/ Segment output	O	Doubles as a 4-bit output port (The output format is equivalent to port D.) and as the segment signal output pin for LCD.	 <p>See Note 3) for the output circuit format.</p>
PH3/ SEG23 to PH0/ SEG20	Port H/ Segment output	O	Doubles as a 4-bit output port (The output format is equivalent to port D.) and as the segment signal output pin for LCD. (Possible to designate in bit units.)	
PG3/ SEG19 to PG0/ SEG16	Port G Segment output	O	Doubles as a 4-bit output port (The output format is equivalent to port D.) and as the segment signal output pin for LCD.	
SEG0 to SEG15	Segment output	O	Segment signal output pin for LCD	 <p>The transfer gate input signal is controlled based on respective bias method in advance.</p>
COM0 to COM3	Common output	O	Common signal output pin for LCD	 <p>Transfer gate output</p>

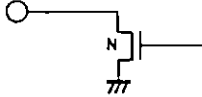
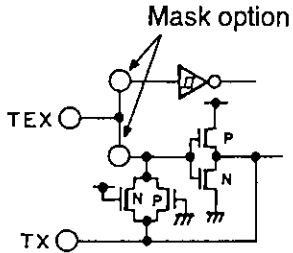
Symbol	Name	I/O	Description	Equivalent Circuit
V <sub>LC1</sub> to V <sub>LC3</sub>	Power supply for LCD	—	Bias power supply pin for LCD	
V <sub>L</sub>	Cut-off output	O	Control pin which cuts off the current input to the bias resistor for the external LCD during standby.	
TEX	32kHz T/C clock input	I	Input pin for 32kHz timer clock generated circuit. Connect the 32.768kHz crystal oscillator between the TEX and TX. When using as the event clock input, connect the clock oscillation source to the TEX pin and open the TX pin.	
TX	32kHz T/C clock output	O	Output of clock generated circuit	
V <sub>REF</sub>	Reference voltage input	I	Reference voltage input for power supply voltage resetting circuit. Connect the zener diode normally.	

For all output ports, the output states of ports during standby possible to be programmed the state holding before standby or the change to the high impedance.

When the pull-up resistor is selected, it becomes a pulled-up state even it is input port.

During standby, it is impossible to change to the high impedance of PY0 and PY1 in the inverter output state. To change to the high impedance, select the pull-up resistor output, and then set to the high level output ("1" state).

- Note 1)** Possible to select out of the following two ways for the output circuit format. (port units:programmable)
- (a) Inverter output
  - (b) Pull-up resistor output

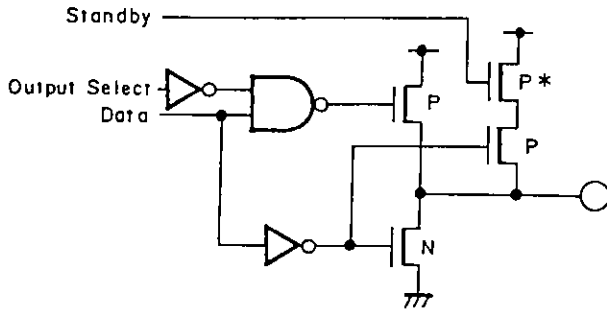

- Note 2)** Possible to select out of the following two ways for the output circuit format. (port units:programmable)
- (a) Tri-state output
  - (b) Pull-up resistor output

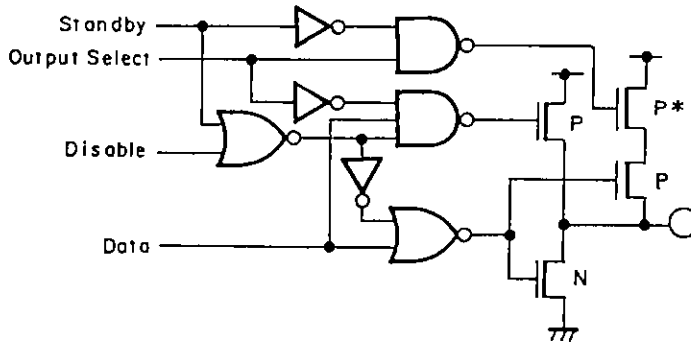

- Note 3)** Possible to select out of the the following two ways for the output circuit format. (port units:programmable)
- (a) Inverter output
  - (b) Pull-up resistor output

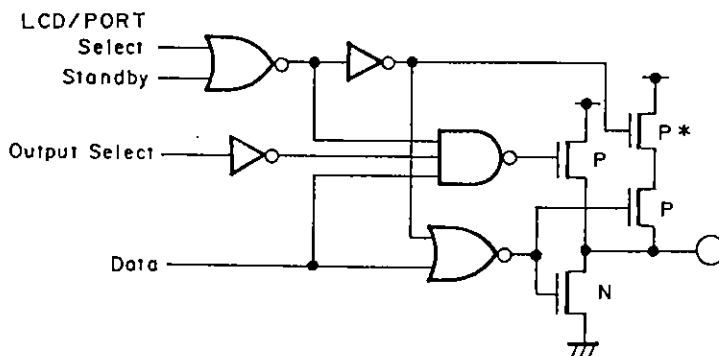

\* As the output pull-up resistor is CMOS pull-up output of about 10kΩ , the pull-up resistor becomes OFF state during "L" output.



## Absolute Maximum Ratings

Item	Symbol	Rating	Unit	Remarks
Power supply voltage	V <sub>DD</sub>	- 0.3 to +7.0	V	
LCD bias voltage	V <sub>LC1</sub> , V <sub>LC2</sub> , V <sub>LC3</sub>	- 0.3 to +7.0 *1	V	
Input voltage	V <sub>IN</sub>	- 0.3 to +7.0 *1	V	
Output voltage	V <sub>OUT</sub>	- 0.3 to +7.0 *1	V	
High level output current	I <sub>OH</sub>	- 5	mA	General purpose port *2: per pin
High level total output current	Σ I <sub>OH</sub>	- 50	mA	Entire pins total
Low level output current	I <sub>OL</sub>	15	mA	General purpose port *2: per pin
	I <sub>OLC</sub>	20	mA	High current port *3: per pin
Low level total output current	Σ I <sub>OL</sub>	100	mA	Entire pins total
Operating temperature	T <sub>opr</sub>	- 20 to +75	°C	
Storage temperature	T <sub>stg</sub>	- 55 to +150	°C	
Allowable power dissipation	P <sub>D</sub>	600	mW	QFP

\*1) V<sub>LC1</sub>, V<sub>LC2</sub>, V<sub>LC3</sub>, V<sub>IN</sub> and V<sub>OUT</sub> should not exceed V<sub>DD</sub>+0.3V.

\*2) Specifies the output current of the general purpose I/O port PA to PI, SO,  $\overline{SC}$ , PY0 and PY1.

\*3) The high current operation transistors are the N-CH transistors of the PC and PD ports.

**Note)** Usage exceeding absolute maximum ratings may permanently impair the LSI. Normal operation should better take place under the recommended operating conditions. Exceeding those conditions may adversely affect the reliability of the LSI.

## Recommended Operating Conditions

(V<sub>SS</sub>=0V)

Item	Symbol	Min.	Max.	Unit	Remarks
Power supply voltage	V <sub>DD</sub>	4.5	5.5	V	Guaranteed range of operation by EXTAL clock
		2.5	5.5	V	Guaranteed range of operation by TEX clock, guaranteed range of data hold during STOP.
LCD bias voltage	V <sub>LC1</sub> , V <sub>LC2</sub> , V <sub>LC3</sub>	V <sub>SS</sub>	V <sub>DD</sub>	V	Liquid crystal power supply range *1
High level input voltage	V <sub>IH</sub>	0.7V <sub>DD</sub>	V <sub>DD</sub>	V	
	V <sub>IHS</sub>	0.8V <sub>DD</sub>	V <sub>DD</sub>	V	Hysteresis input *2
	V <sub>IHEX</sub>	V <sub>DD</sub> -0.4	V <sub>DD</sub> +0.3	V	EXTAL pin *3
Low level input voltage	V <sub>IL</sub>	0	0.3V <sub>DD</sub>	V	
	V <sub>ILS</sub>	0	0.2V <sub>DD</sub>	V	Hysteresis input *2
	V <sub>ILEX</sub>	- 0.3	0.4	V	EXTAL pin *3
Operating temperature	T <sub>opr</sub>	- 20	+75	°C	

\*1) The optimum value is determined by the characteristics of the liquid crystal display element used.

\*2) The TEX pin when the counter mode is selected by each of INT, RMC, PX0, PX2, PY2, PY3,  $\overline{RST}$  pins and mask option.

\*3) Specified only during external clock input.

**Electrical Characteristics**  
**DC characteristics**

(Ta = -20 to +75 °C, Vss = 0V)

Item	Symbol	Pin	Condition	Min.	Typ.	Max.	Unit		
High level output voltage	V <sub>OH</sub>	PA to PI*1 PX0, PX1 PY0, PY1 VL (VoL only) RST (VoL only) PC*1, PD*1	V <sub>DD</sub> =4.5V, I <sub>OH</sub> = -0.5mA*2	4.0			V		
			V <sub>DD</sub> =4.5V, I <sub>OH</sub> = -1.0mA*2	3.5			V		
			V <sub>DD</sub> =4.5V, I <sub>OH</sub> = -10 μA*3	4.0			V		
			V <sub>DD</sub> =4.5V, I <sub>OH</sub> = -200 μA*3	2.4			V		
Low level output voltage	V <sub>OL</sub>	RST (VoL only) PC*1, PD*1	V <sub>DD</sub> =4.5V, I <sub>OL</sub> =1.8mA			0.4	V		
			V <sub>DD</sub> =4.5V, I <sub>OL</sub> =3.6mA			0.6	V		
			V <sub>DD</sub> =4.5V, I <sub>OL</sub> =12mA			1.5	V		
Input current	I <sub>IHE</sub>	EXTAL	V <sub>DD</sub> =5.5V, V <sub>IH</sub> =5.5V	0.5		40	μA		
	I <sub>I LE</sub>		V <sub>DD</sub> =5.5V, V <sub>IL</sub> =0.4V	-0.5		-40	μA		
	I <sub>IHT</sub>	TEX*4	V <sub>DD</sub> =5.5V, V <sub>IH</sub> =5.5V	0.1		10	μA		
	I <sub>I LT</sub>			-0.1		-10	μA		
	I <sub>I LR</sub>	RST*5	V <sub>DD</sub> =5.5V, V <sub>IL</sub> =0.4V			-400	μA		
	I <sub>I L</sub>	PA*6, PB*6, PE*6, PF*6, PI*6, PX0*6, PX1*6, PX2*6, PY0*7, PY1*7, PY2*8, PY3*8, INT*8, RMC*8, RST*5, TEX*4				±10	μA		
High impedance I/O leakage current	I <sub>I Z</sub>		V <sub>DD</sub> =5.5V			±10	μA		
Common output impedance	R <sub>COM</sub>	COM0 to COM3	V <sub>DD</sub> =5V V <sub>LC1</sub> =3.75V		3	5	kΩ		
Segment output impedance	R <sub>SEG</sub>	SEG0 to SEG15 SEG16 to SEG3*1	V <sub>LC2</sub> =2.5V V <sub>LC3</sub> =1.25V		5	15	kΩ		
Current power supply	I <sub>DD1</sub>	V <sub>DD</sub>	Entire output pins open V <sub>DD</sub> =5.5V, 4.19MHz Crystal oscillation (C1=C2=22pF)		7	20	mA		
	I <sub>DD2</sub>		V <sub>DD</sub> =3V, 32kHz Crystal oscillation (C1=C2=18pF)		50	250	μA		
	I <sub>DDSP1</sub>		SLEEP mode V <sub>DD</sub> =5.5V, 4.19MHz oscillation		5	12	mA		
	I <sub>DDSP2</sub>		V <sub>DD</sub> =3V, 32kHz oscillation		40	200	μA		
	I <sub>DD S1</sub>		STOP mode V <sub>DD</sub> =3V, with 32kHz T/C		7	40	μA		
	I <sub>DD S2</sub>		V <sub>DD</sub> =3V, without 32kHz T/C (For mask option select counter)				10	μA	
	Input capacity		C <sub>IN</sub>	Other than V <sub>LC1</sub> to V <sub>LC3</sub> , COM0 to COM3, SEG0 to SEG15, SEG16 to SEG31,*1 V <sub>DD</sub> , V <sub>SS</sub> pins	Clock 1MHz 0V other than the measured pins		10	20	pF

- \* 1) The PC, PD, PG and PH show when the combined pins are selected as the port, and SEG16 to SEG31 show when the combined pins are selected as the segment output.
- \* 2) It is when the respective pins of PA to PI, PX0 and PX1 select the tri-state output circuit, and PY0 and PY1 are when the inverter output circuit is selected.
- \* 3) It is when the respective pins of PA to PI, PX0, PX1, PY0 and PY1 select the pull-up resistor.
- \* 4) The TEX pin specifies the input current when the crystal oscillation is selected by the mask option, and specifies the leakage current when the schmitt input is selected.
- \* 5) The  $\overline{\text{RST}}$  pin specifies the input current when the pull-up resistor is selected, and specifies leakage current when non-resistor is selected.
- \* 6) The respective pins of PA, PB, PE, PF, PI, PX0 and PX1 specify the input current when the pull-up resistor is selected, and specify the leakage current when the port state during using the tri-state output circuit or standby is selected at high impedance.
- \* 7) The respective pins of PY0 and PY1 specify the input current when the pull-up resistor is selected, and specify the leakage current when the port state during standby is selected at high impedance.
- \* 8) The respective pins of PX2, PY2, PY3, INT and RMC only specify the leakage current.

## AC characteristics

### (1) Clock timing

( $T_a = -20$  to  $+75^\circ\text{C}$ ,  $V_{DD}=4.5$  to  $5.5\text{V}$ ,  $V_{SS}=0\text{V}$ )

Item	Symbol	Pin	Condition	Min.	Typ.	Max.	Unit
System clock frequency	$f_c$	XTAL EXTAL	Fig. 1, Fig. 2	1		5	MHz
System clock input pulse width	$t_{xL}$ $t_{xH}$	EXTAL	Fig. 1, Fig. 2 (External clock drive)	90			ns
System clock input rising and falling times	$t_{cR}$ $t_{cF}$					200	ns
System clock frequency	$f_{cs}$	TEX *2 TX	$V_{DD}=2.5$ to $5.5\text{V}$ Fig. 3		32.768		kHz
Event count clock input pulse width	$t_{EL}$ $t_{EH}$	$\overline{\text{EC}}$	Fig. 4	$t_{sys} * 1$ $+0.05$			$\mu\text{s}$
Event count clock input rising and falling times	$t_{ER}$ $t_{EF}$	$\overline{\text{EC}}$	Fig. 4			20	ms
Event count input clock input pulse width	$t_{TL}$ $t_{TH}$	TEX *3	Fig. 4	10			$\mu\text{s}$
Event count input clock rising and falling times	$t_{TR}$ $t_{TF}$	TEX *3	Fig. 4			20	ms

- \* 1)  $t_{sys}$  in the EXTAL input clock is  $8/f_c$   
 $t_{sys}$  in the TEX input clock is  $4/f_{cs}$
- \* 2) Specified when the crystal oscillation mode is selected by the mask option.
- \* 3) Specified when the counter mode is selected by the mask option.

**Note)** When adjusting the frequency accurately, there may be cases in which they may differ from Fig. 2.

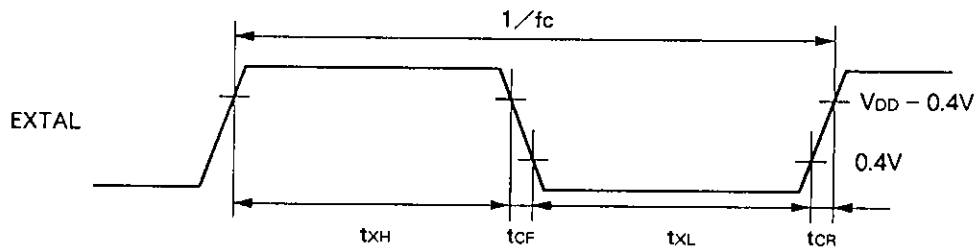

Fig. 1 Clock timing

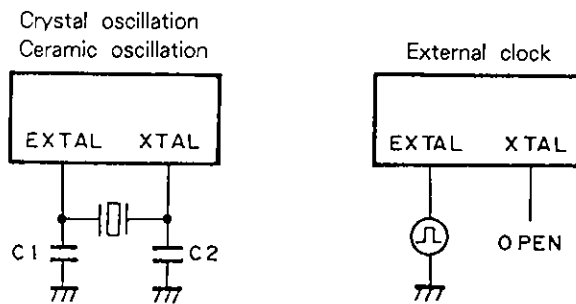

Fig. 2 Clock applying condition

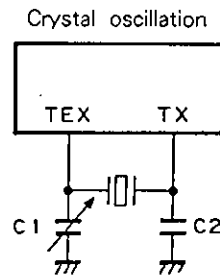

Fig. 3 32kHz clock applying condition

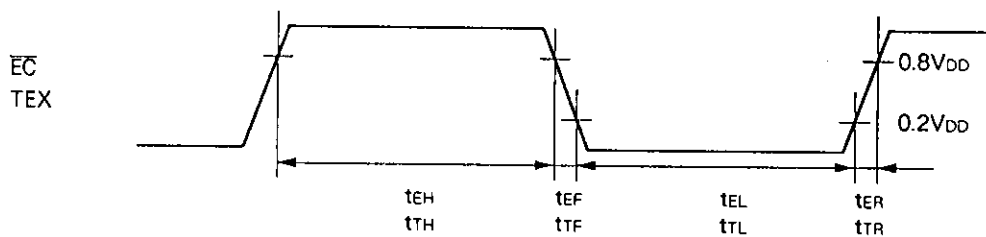

Fig. 4 Event count clock timing

(2) Serial transfer

( $T_a = -20$  to  $+75$  °C,  $V_{DD}=4.5$  to  $5.5V$ ,  $V_{SS}=0V$ )

Item	Symbol	Pin	Condition	Min.	Max.	Unit
Serial transfer clock ( $\overline{SC}$ ) cycle time	tkcy	$\overline{SC}$	Input mode	$t_{sys}/4+1.42$		$\mu s$
			Output mode	$2t_{sys}$		$\mu s$
Serial transfer clock ( $\overline{SC}$ ) high and low level widths	tkh tkl	$\overline{SC}$	Input mode	$t_{sys}/8+0.7$		$\mu s$
			Output mode *1	$t_{sys} - 0.1$		$\mu s$
			Output mode *2	$t_{sys} - 1.6$		$\mu s$
Serial data input setup time (against $\overline{SC}$ ↑)	tsik	SI	$\overline{SC}$ input mode	0.1		$\mu s$
			$\overline{SC}$ output mode	0.2		$\mu s$
Serial data input hold time (against $\overline{SC}$ ↑)	tksl	SI	$\overline{SC}$ input mode	$t_{sys}/8+0.5$		$\mu s$
			$\overline{SC}$ output mode	0.1		$\mu s$
High data delay time from $\overline{SC}$ falling *3	tkso	SO			$t_{sys}/8+0.5$	$\mu s$
High data delay time from $\overline{SC}$ falling *4	tkso	SO			$t_{sys}/8+1.6$	$\mu s$
Low data delay time from $\overline{SC}$ falling	tkso	SO			$t_{sys}/8+0.5$	$\mu s$

**Note)**  $t_{sys}$  in the EXTAL input clock is  $8/f_c$ . (It is impossible to use in TEX input clock.)

\* 1) It is specified when  $\overline{SC}$  pin is selected to the tri-state output by the program.

\* 2) It is specified when  $\overline{SC}$  pin is selected to the pull-up resistance by the program.

As the  $t_{sys}$  receives restriction by this item, take notice that it limits the upper limit of the system clock frequency  $f_c$ .

\* 3) It is specified when SO pin is selected to the tri-state output by the program.

\* 4) It is specified when SO pin is selected to the pull-up resistance by the program.

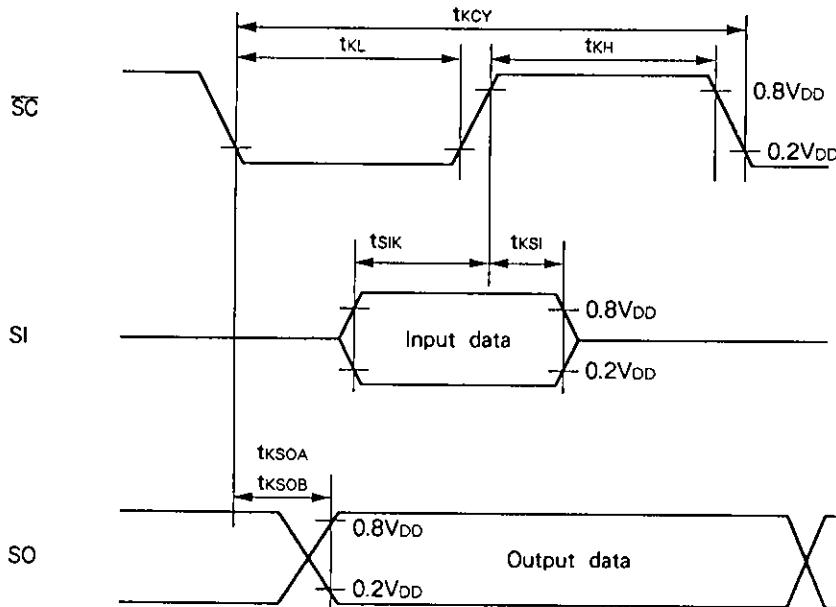

Fig. 5 Serial transfer timing

(3) A/D converter (Ta= - 20 to +75 °C , Vss=0V)

Analog input voltage	Pin	Condition	Digital conversion value
0.0 to 0.33V	AD0 to AD7	V <sub>DD</sub> =5V	000
0.82 to 1.29V			001
1.78 to 2.21V			010
2.69 to 3.06V			011
3.56 to 4.06V			100
4.62 to 5.0V			101

**Note)** The digital conversion value are the values when C9H address in the program are read.

(4) Power supply voltage detection reset function (Ta= - 20 to +75 °C , Vss=0V)

Item	Symbol	Pin	Condition	Min.	Typ.	Max.	Unit
Power supply voltage detection reset function of operation voltage range	V <sub>LPOP</sub>	V <sub>DD</sub>	Voltage range allowing system operation (32kHz system operation below V <sub>DD</sub> =4.5V)	2.5		5.5	V
Power supply voltage drop detection function	V <sub>POP</sub>	V <sub>DD</sub>	When V <sub>REF</sub> pin voltage is 3.3V Flag set when voltage drops System reset when voltage rises	3.8	4.0	4.2	V

The graph in Fig. 6 shows the relationship between the power supply voltage V<sub>DD</sub> and reference voltage V<sub>REF</sub> of the power supply voltage detection reset function.

**Note)** The graph in Fig. 6 serves as guide to the function operation area obtained using average devices. Individual adjustment is needed when Zener diodes, etc., are connected to the V<sub>REF</sub> pin.

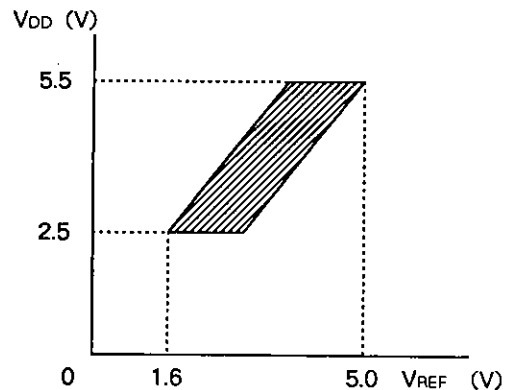

**Fig. 6 Power supply voltage detection reset function chart**

(5) Others

( $T_a = -20$  to  $+75^\circ\text{C}$ ,  $V_{DD}=4.5$  to  $5.5\text{V}$ ,  $V_{SS}=0\text{V}$ )

Item	Symbol	Pin	Condition	Min.	Max.	Unit
External interruption high and low level widths	$t_{IH}$ , $t_{IL}$	INT	During edge detection mode	$t_{sys}+0.05$		$\mu\text{s}$
Reset input low level width	$t_{RSL}$	$\overline{\text{RST}}$		$2t_{sys}^*$		$\mu\text{s}$
Wake-up input high level width	$t_{WPH}$	WP	STOP mode	500		ns
			SLEEP mode	$t_{sys}+0.05$		$\mu\text{s}$
Wake-up input low level width	$t_{WPL}$	PA	STOP mode	500		ns
			SLEEP mode	$t_{sys}+0.05$		$\mu\text{s}$

**Note)**  $t_{sys}$  in the EXTAL input clock is  $8/f_c$   
 $t_{sys}$  in the TEX input clock is  $4/f_c$

\* For resetting when operating in TEX input clock, hold the low level more than the oscillation stabilizing time of EXTAL input clock.

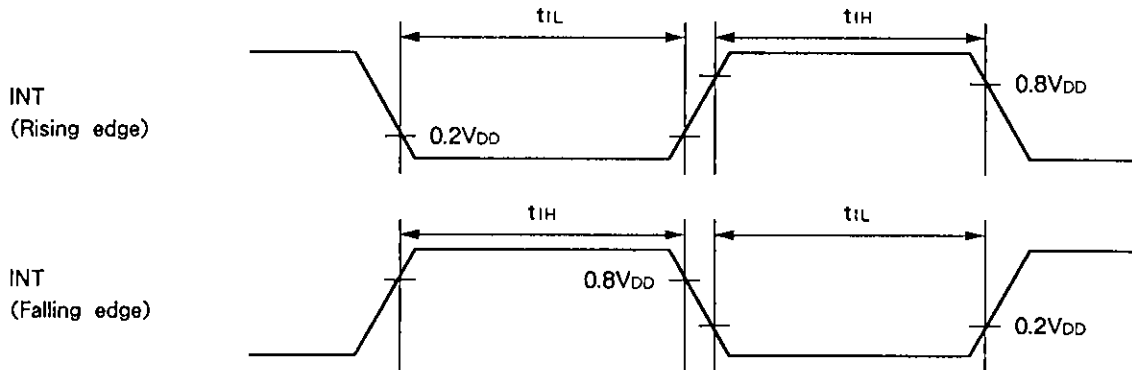

Fig. 7 Interruption Input timing

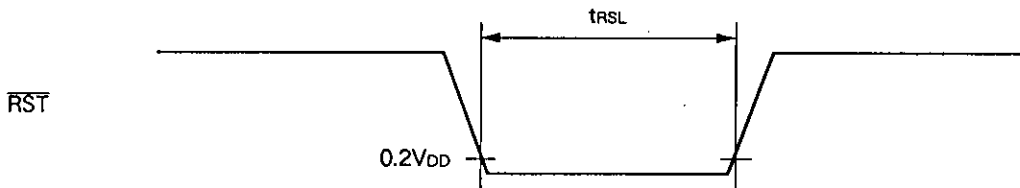

Fig. 8 Reset Input timing

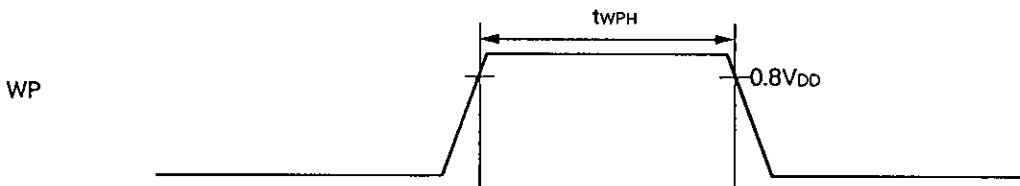

Fig. 9 Wake-up Input timing

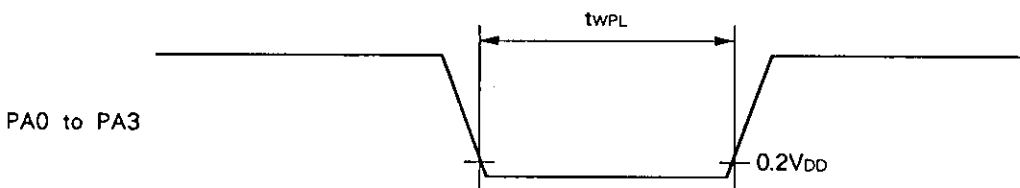

Fig. 10 Wake-up Input timing

**Power on reset \***

(Ta = -20 to +75 °C, Vss=0V)

Item	Symbol	Pin	Condition	Min.	Max.	Unit
Power supply rising time	tr	VDD	Power on reset	0.05	50	ms
Power supply cut-off time	toff		Repetitive power on reset	1		ms

\* Specifies only when power on reset function is selected.

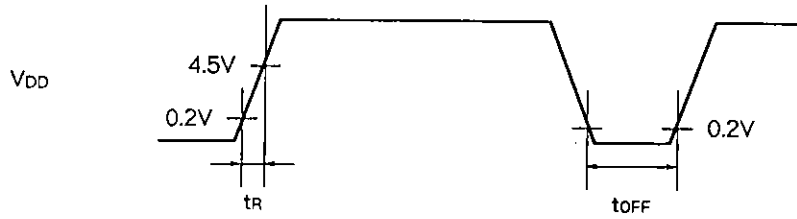

The power supply should rise smoothly.

**Fig. 11 Power on reset**

**Notes on Operation**

See Fig. 12, Additive capacity calculation chart, when using the crystal oscillator and select the appropriate capacity.

(Ta = -20 to +75 °C, VDD = 4.5 to 5.5V)

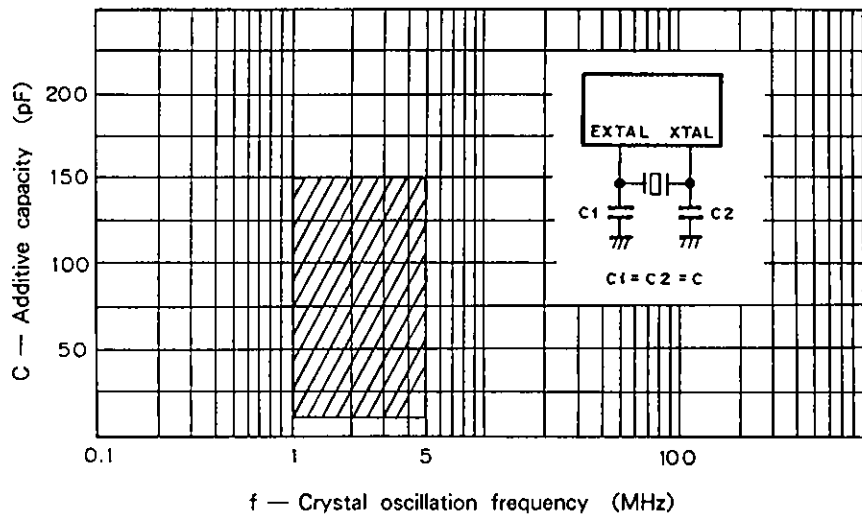

**Fig. 12 Crystal oscillation circuit additive capacity calculation chart**

**Note)** The above chart shows a range in which the average quartz resonator has a relatively fast oscillation rising edge and stable characteristics. The capacity should be selected to correspond to the appropriate constant for each quartz resonator, should the frequency of the quartz resonator be accurately adjusted.

Fig. 13 shows recommended circuit and oscillators. Use the trimmer capacitor to C1, in the case of accurate adjustment of the oscillation frequency.



(i) Main clock (4.19MHz)

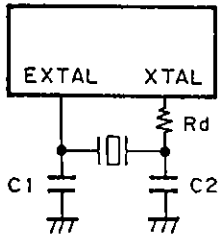

(i)

Manufacturer	Model	Frequency	C1	C2	Rd
MURATA MFG CO., LTD.	CSA4.19MG040	4.19 MHz	100pF	100pF	—
	CST4.19MGW040	4.19 MHz	(built in)	(built in)	—

Manufacturer	Model	Frequency	C1	C2	Rd
CITIZEN WATCH CO., LTD.	CSA-309	4.19 MHz	10pF (20pF trimmer)	10pF	—
NIHON DEMPA KOGYO CO., LTD.	AT-51	4.19 MHz	15pF (20pF trimmer)	15pF	6.8kΩ
KINSEKI LTD.	HC-49/U-S	4.19 MHz	22pF	22pF	3.3kΩ

(ii) Sub clock (32kHz)

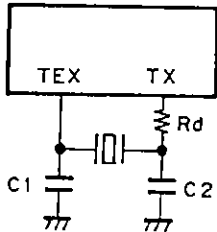

(ii)

Manufacturer	Model	Frequency	C1	C2	Rd
CITIZEN WATCH CO., LTD.	CFS-308	32.768 kHz	18pF (20pF trimmer)	18pF	—
NIHON DEMPA KOGYO CO., LTD.	MX-38T	32.768 kHz	22pF (20pF trimmer)	22pF	470kΩ
KINSEKI LTD.	P3	32.768 kHz	22pF (20pF trimmer)	22pF	330kΩ

Fig. 13 Recommended oscillation circuit

When using the A/D converter as the key input, it is recommended that the circuit structure shown in Fig. 14 be used.

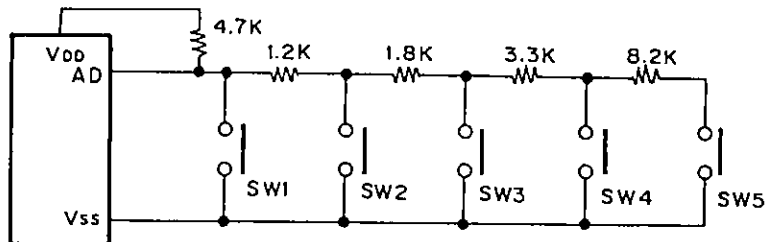

(Resistance is all E12 series)

Fig. 14 Recommended example of key circuit by A/D converter

Package Outline Unit: mm

80pin QFP (Plastic) 1.6g

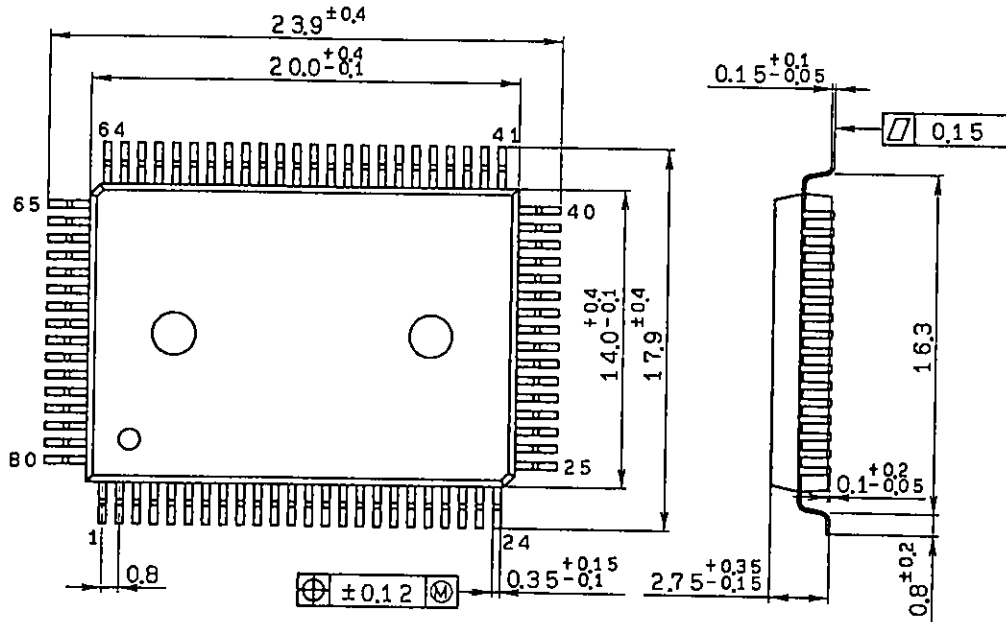

SONY NAME	QFP-80P-L01
EIAJ NAME	*QFP080-P-1420-A
JEDEC CODE	—