

Features

- 3.0V to 5.5V Operating Range
- Advanced Low Voltage, Zero Power, Electrically Erasable Programmable Logic Device
- Edge-Sensing “Zero” Power
- Low Voltage Equivalent of ATF22V10CZ
- “Zero” Standby Power (25 μ A Maximum)
- Ideal for Battery Powered Systems
- 25 ns Maximum Propagation Delay
- CMOS and TTL Compatible Inputs and Outputs
- Latch Feature Hold Inputs to Previous Logic States
- Advanced E² Technology
 - Reprogrammable
 - 100% Tested
- High Reliability CMOS Process
 - 20 Year Data Retention
 - 100 Erase/Write Cycles
 - 2,000V ESD Protection
 - 200 mA Latchup Immunity
- Commercial and Industrial Temperature Ranges
- Dual-in-Line and Surface Mount Standard Pinouts



High
Performance
E² PLD

ATF22LV10CZ

Block Diagram

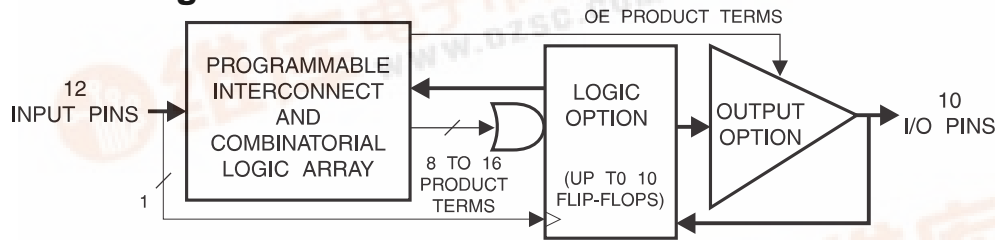

Pin Configurations

Pin Name	Function
CLK	Clock
IN	Logic Inputs
I/O	Bidirectional Buffers
Vcc	(3 to 5.5V) Supply

TSSOP Top View

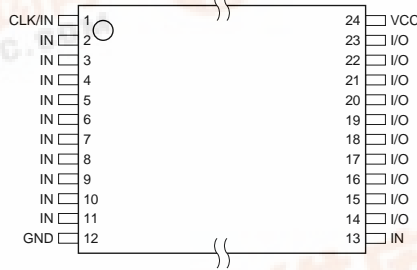

DIP/SOIC

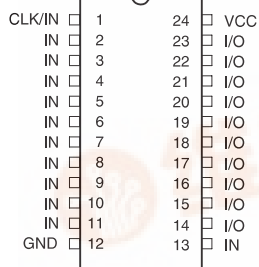

PLCC

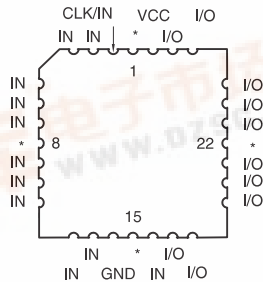

Top view

Note: For PLCC, pins 1, 8, 15, and 22 can be left unconnected. For superior performance, connect Vcc to pin 1 and GND to pins 8, 15, and 22.





Description

The ATF22LV10CZ is a high performance CMOS (Electrically Erasable) Programmable Logic Device (PLD) which utilizes Atmel's proven electrically erasable Flash memory technology and provides 25 ns speed with stand-by current of 25 μ A maximum. All speed ranges are specified over the 3.0V to 5.5V range for industrial and commercial temperature ranges.

The ATF22LV10CZ provides a low voltage and edge-sensing "zero" power CMOS PLD solution with "zero" standby power (5 μ A typical). The ATF22LV10CZ powers down automatically to the zero power mode through Atmel's patented Input Transition Detection (ITD) circuitry when the device is idle. The ATF22LV10CZ is capable of

operating at supply voltages down to 3.0V. Pin "keeper" circuits on input and output pins hold pins to their previous logic levels when idle, which eliminate static power consumed by pull-up resistors.

The ATF22LV10CZ macrocell incorporates a variable product term architecture. Each output is allocated from 8 to 16 product terms which allows highly complex logic functions to be realized. Two additional product terms are included to provide synchronous reset and asynchronous reset. These additional product terms are common to all 10 registers and are automatically cleared upon power up. Register Preload simplifies testing. A Security Fuse prevents unauthorized copying of programmed fuse patterns.

Absolute Maximum Ratings*

Temperature Under Bias.....	-40°C to +85°C
Storage Temperature.....	-65°C to +150°C
Voltage on Any Pin with Respect to Ground.....	-2.0V to +7.0V ⁽¹⁾
Voltage on Input Pins with Respect to Ground During Programming.....	-2.0V to +14.0V ⁽¹⁾
Programming Voltage with Respect to Ground.....	-2.0V to +14.0V ⁽¹⁾

*NOTICE: Stresses beyond those listed under "Absolute Maximum Ratings" may cause permanent damage to the device. This is a stress rating only and functional operation of the device at these or any other conditions beyond those indicated in the operational sections of this specification is not implied. Exposure to absolute maximum rating conditions for extended periods may affect device reliability.

Note: 1. Minimum voltage is -0.6V dc, which may undershoot to -2.0V for pulses of less than 20 ns. Maximum output pin voltage is Vcc + 0.75V dc, which may overshoot to 7.0V for pulses of less than 20 ns.

DC and AC Operating Conditions

	Commercial	Industrial
Operating Temperature (Case)	0°C - 70°C	-40°C - 85°C
Vcc Power Supply	3.0V - 5.5V	3.0V - 5.5V

Functional Logic Diagram Description

The Functional Logic Diagram describes the ATF22LV10CZ architecture.

The ATF22LV10CZ has 12 inputs and 10 I/O macrocells. Each macrocell can be configured into one of four output configurations: active-high/low or registered/combinatorial. The universal architecture of the ATF22LV10CZ can be programmed to emulate most 24-pin PAL devices.

Unused product terms are automatically disabled by the compiler to decrease power consumption. A Security Fuse, when programmed, protects the contents of the ATF22LV10CZ. Eight bytes (64 fuses) of User Signature are accessible to the user for purposes such as storing project name, part number, revision or date. The User Signature is accessible regardless of the state of the Security Fuse.

DC Characteristics

Symbol	Parameter	Condition	Min	Typ	Max	Units
I _{IL}	Input or I/O Low Leakage Current	$0 \leq V_{IN} \leq V_{IL(MAX)}$			-10	μA
I _{IH}	Input or I/O High Leakage Current	$V_{CC} - 0.7V \leq V_{IN} \leq V_{CC}$			10	μA
I _{CC}	Clocked Power Supply Current	V _{CC} = MAX, Outputs Open, f = 15 MHz	Com.	55	85	mA
			Ind.	60	90	mA
I _{SB}	Power Supply Current, Standby	V _{CC} = MAX, V _{IN} = MAX, Outputs Open	Com.	5	25	μA
			Ind.	5	50	μA
I _{OS} ⁽¹⁾	Output Short Circuit Current	V _{OUT} = 0.5V			-130	mA
V _{IL}	Input Low Voltage		-0.5		0.8	V
V _{IH}	Input High Voltage		2.0		V _{CC} + 0.75	V
V _{OL}	Output Low Voltage	V _{IN} = V _{IH} or V _{IL} V _{CC} = MIN, I _{OL} = 8 mA			0.5	V
V _{OH}	Output High Voltage	V _{IN} = V _{IH} or V _{IL} , V _{CC} = MIN, I _{OH} = -4.0 mA		2.4		V

Note: 1. Not more than one output at a time should be shorted. Duration of short circuit test should not exceed 30 sec.



AC Waveforms

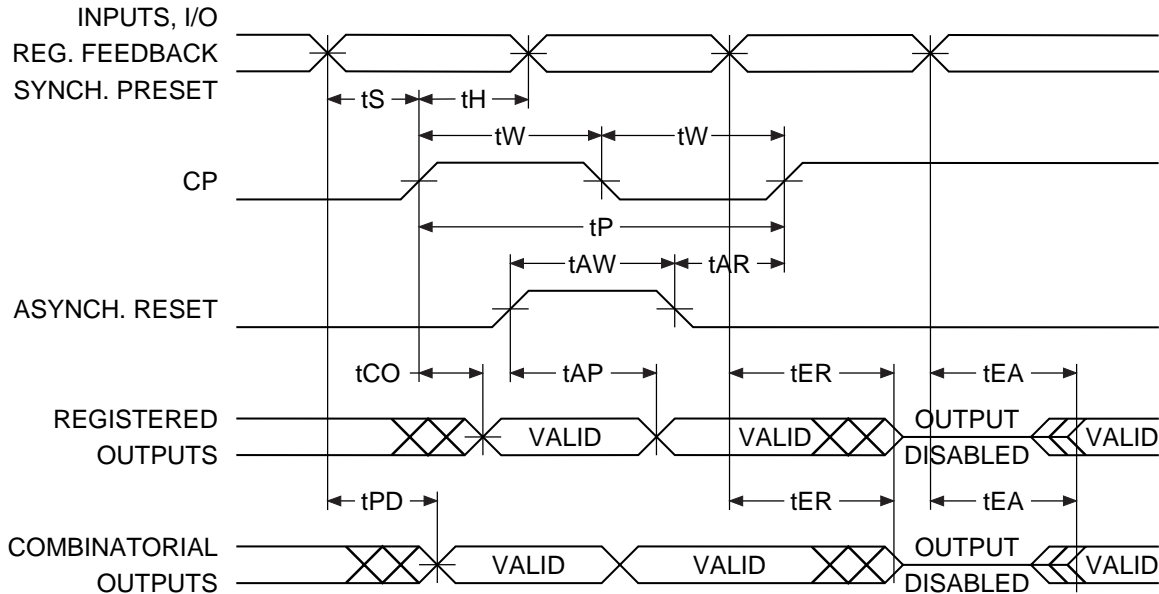

AC Characteristics ⁽¹⁾

Symbol	Parameter	-25		Units
		Min	Max	
t _{PD}	Input to Feedback to Non-Registered Output	3	25	ns
t _{CF}	Clock to Feedback		13	ns
t _{CO}	Clock to Output	2	15	ns
t _S	Input or Feedback Setup Time	15		ns
t _H	Input Hold Time	0		ns
t _P	Clock Period	25		ns
t _W	Clock Width	12.5		ns
F _{MAX}	External Feedback 1/(t _S + t _{CO})	33.3		MHz
	Internal Feedback 1/(t _S + t _{CF})	35.7		MHz
	No Feedback 1/(t _P)	40.0		MHz
t _{EA}	Input to Output Enable	3	25	ns
t _{ER}	Input to Output Disable	3	25	ns
t _{AP}	Input or I/O to Asynchronous Reset of Register	3	25	ns
t _{SP}	Setup Time, Synchronous Preset	15		ns
t _{AW}	Asynchronous Reset Width	25		ns
t _{AR}	Asynchronous Reset Recovery Time	25		ns
t _{SPR}	Synchronous Preset to Clock Recovery Time	15		ns

Note: 1. See ordering information for valid part numbers.

Input Test Waveforms and Measurement Levels

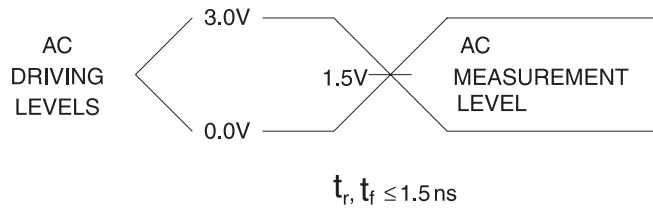

Output Test Loads

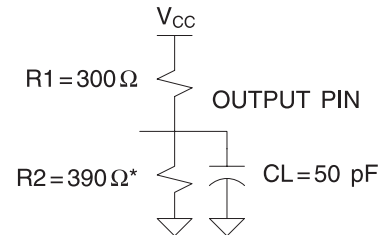

Note: Similar competitors' devices are specified with slightly different loads. These load differences may affect output signals' delay and slew rate. Atmel devices are tested with sufficient margins to meet compatible device specification conditions.

Pin Capacitance (f = 1 MHz, T = 25°C) ⁽¹⁾

	Typ	Max	Units	Conditions
C_{IN}	5	8	pF	$V_{IN} = 0V$
C_{OUT}	6	8	pF	$V_{OUT} = 0V$

Note: 1. Typical values for nominal supply voltage. This parameter is only sampled and is not 100% tested.



Power Up Reset

The registers in the ATF22LV10CZ are designed to reset during power up. At a point delayed slightly from V_{CC} crossing V_{RST} , all registers will be reset to the low state. The output state will depend on the polarity of the buffer.

This feature is critical for state machine initialization. However, due to the asynchronous nature of reset and the uncertainty of how V_{CC} actually rises in the system, the following conditions are required:

1. The V_{CC} rise must be monotonic and start below 0.7V
2. After T_{PR} , all input and feedback setup times must be met before driving the clock pin high.
3. The clock must remain stable during T_{PR} .

Preload of Register Outputs

The ATF22LV10CZ's registers are provided with circuitry to allow loading of each register with either a high or a low. This feature will simplify testing since any state can be forced into the registers to control test sequencing. A JEDEC file with preload is generated when a source file with vectors is compiled. Once downloaded, the JEDEC file preload sequence will be done automatically by most of the approved programmers after the programming.

Electronic Signature Word

There are 64 bits of programmable memory that are always available to the user, even if the device is secured. These bits can be used for user-specific data.

Security Fuse Usage

A single fuse is provided to prevent unauthorized copying of the ATF22LV10CZ fuse patterns. Once programmed, fuse verify and preload are inhibited. However, the 64-bit User Signature remains accessible.

The security fuse should be programmed last, as its effect is immediate.

Programming/Erasing

Programming/erasing is performed using standard PLD programmers. See CMOS PLD Programming Hardware & Software Support for information on software/programming.

Parameter	Description	Typ	Max	Units
T_{PR}	Power-Up Reset Time	600	1,000	ns
V_{RST}	Power-Up Reset Voltage	2.3	2.7	V

Input and I/O Pin Keepers

All ATF22LV10CZ family members have internal input and I/O pin-keeper circuits. Therefore, whenever inputs or I/Os are not being driven externally, they will maintain their last driven state. This ensures that all logic array inputs

and device outputs are at known states. These are relatively weak active circuits that can be easily overridden by TTL-compatible drivers (see input and I/O diagrams below).

Input Diagram

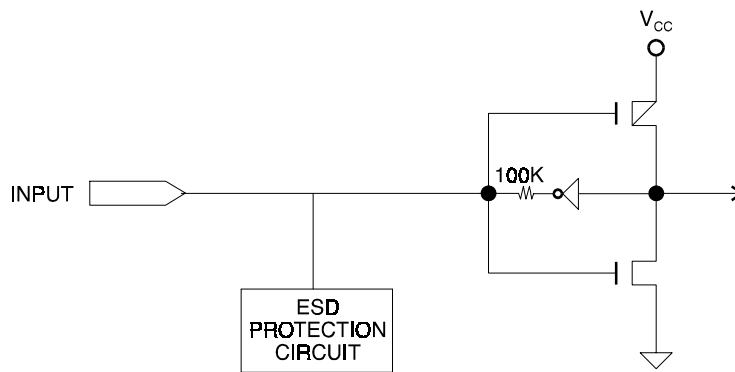

I/O Diagram

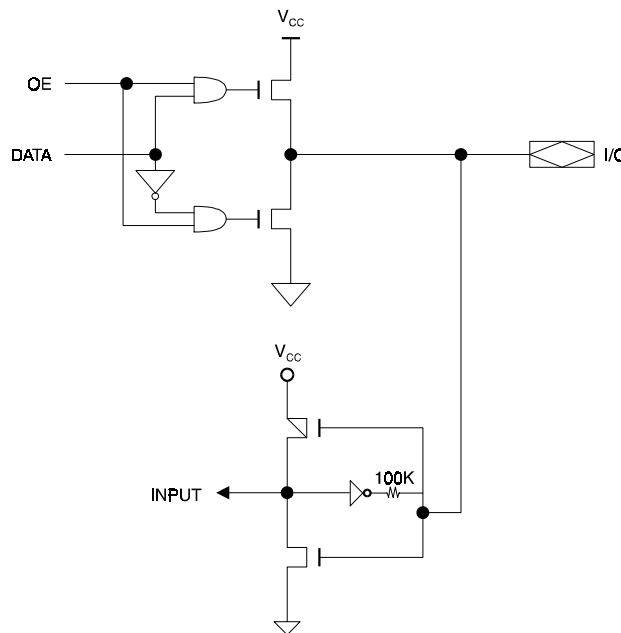



Functional Logic Diagram ATF22LV10CZ

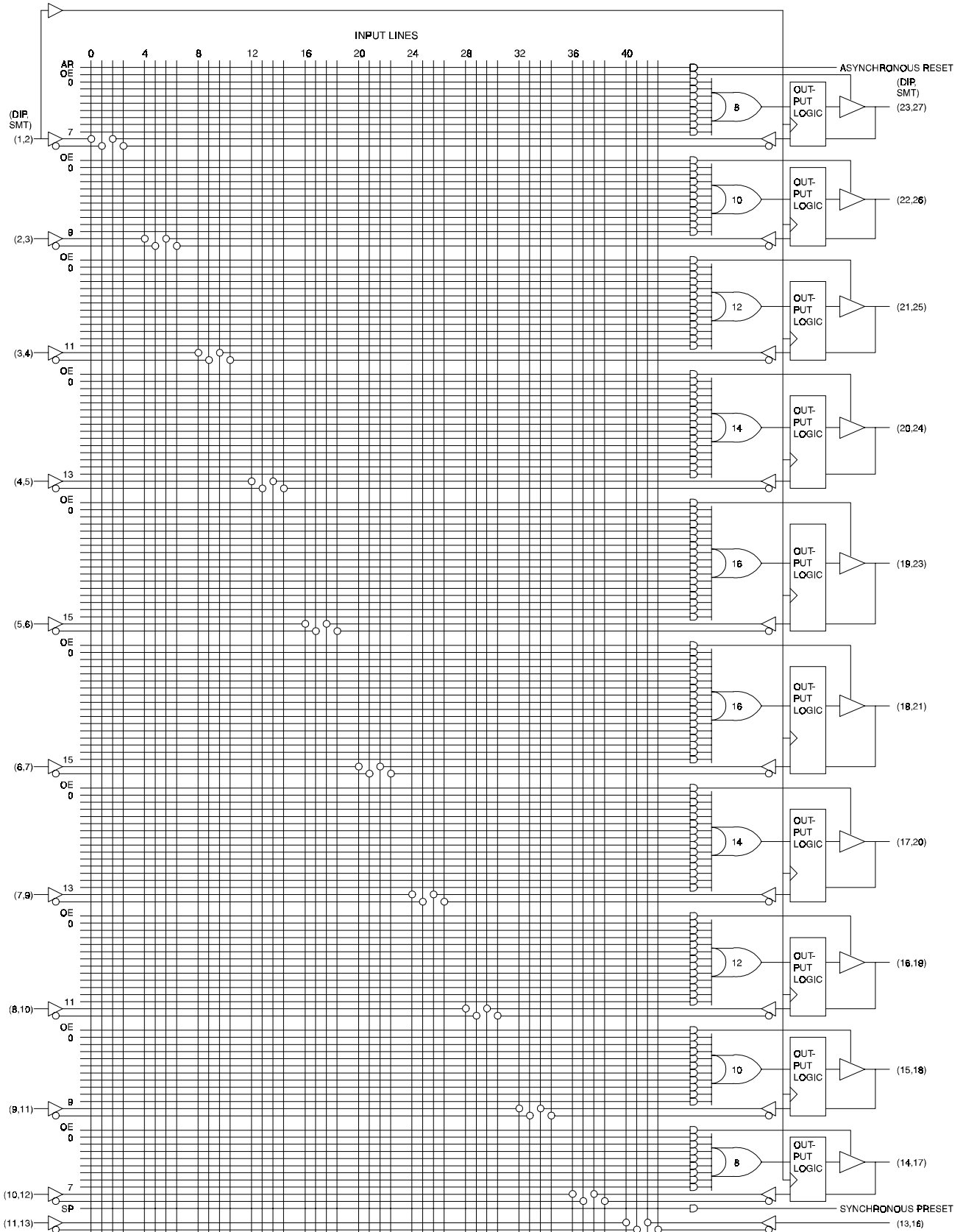

ATF22LV10CZ

t _{PD} (ns)	t _s (ns)	t _{CO} (ns)	Ordering Code	Package	Operation Range
25	15	15	ATF22LV10CZ-25JC ATF22LV10CZ-25PC ATF22LV10CZ-25SC ATF22LV10CZ-25XC	28J 24P3 24S 24X	Commercial (0°C to 70°C)
	15	15	ATF22LV10CZ-25JI ATF22LV10CZ-25PI ATF22LV10CZ-25SI ATF22LV10CZ-25XI	28J 24P3 24S 24X	Industrial (-40°C to +85°C)

Package Type	
28J	28-Lead, Plastic J-Leaded Chip Carrier (PLCC)
24P3	24-Lead, 0.300" Wide, Plastic Dual Inline Package (DIP)
24S	24-Lead, 0.300" Wide, Plastic Gull Wing Small Outline (SOIC)
24X	24-Lead, 4.4 mm Wide, Plastic Thin Shrink Small Outline (TSSOP)