

**CZT7090L**  
**SURFACE MOUNT**  
**LOW  $V_{CE(SAT)}$**   
**PNP SILICON POWER TRANSISTOR**

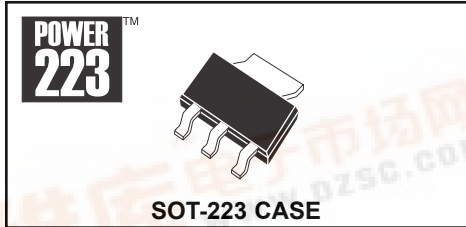

# Central<sup>TM</sup>

## Semiconductor Corp.

**DESCRIPTION:**

The CENTRAL SEMICONDUCTOR CZT7090L is a Low  $V_{CE(SAT)}$  PNP Transistor in a space saving Power SOT-223 surface mount package, designed for DC-DC converters for mobile systems and LAN cards, motor control, power management and strobe flash units.

**MARKING CODE: FULL PART NUMBER**

**MAXIMUM RATINGS:** ( $T_A=25^\circ\text{C}$ )

	SYMBOL		UNITS
Collector-Base Voltage	$V_{CBO}$	50	V
Collector-Emitter Voltage	$V_{CEO}$	40	V
Emitter-Base Voltage	$V_{EBO}$	5.0	V
Continuous Collector Current	$I_C$	3.0	A
Peak Pulse Current	$I_{CM}$	6.0	A
Power Dissipation	$P_D$	2.0	W
Operating and Storage			
Junction Temperature	$T_J, T_{stg}$	-65 to +150	$^\circ\text{C}$
Thermal Resistance	$\theta_{JA}$	62.5	$^\circ\text{C/W}$

**ELECTRICAL CHARACTERISTICS:** ( $T_A=25^\circ\text{C}$  unless otherwise noted)

SYMBOL	TEST CONDITIONS	MIN	TYP	MAX	UNITS
$I_{CBO}$	$V_{CB}=30\text{V}$			100	nA
$I_{CBO}$	$V_{CB}=30\text{V}, T_A=100^\circ\text{C}$			10	$\mu\text{A}$
$I_{EBO}$	$V_{EB}=4.0\text{V}$			100	nA
$BV_{CBO}$	$I_C=100\mu\text{A}$	50			V
$BV_{CEO}$	$I_C=10\text{mA}$	40			V
$BV_{EBO}$	$I_E=100\mu\text{A}$	5.0			V
$V_{CE(SAT)}$	$I_C=500\text{mA}, I_B=5.0\text{mA}$		100	250	mV
$V_{CE(SAT)}$	$I_C=1.0\text{A}, I_B=10\text{mA}$		175	450	mV
$V_{CE(SAT)}$	$I_C=2.0\text{A}, I_B=50\text{mA}$		250	750	mV
$V_{BE(SAT)}$	$I_C=1.0\text{A}, I_B=10\text{mA}$		0.8	1.0	V
$h_{FE}$	$V_{CE}=2.0\text{V}, I_C=10\text{mA}$	200		800	
$h_{FE}$	$V_{CE}=2.0\text{V}, I_C=500\text{mA}$	200			
$h_{FE}$	$V_{CE}=2.0\text{V}, I_C=1.0\text{A}$	180			
$h_{FE}$	$V_{CE}=2.0\text{V}, I_C=2.0\text{A}$	125			
$f_T$	$V_{CE}=5\text{V}, I_C=50\text{mA}, f=50\text{MHz}$	100			MHz

R3 (17-June 2004)

**SOT-223 CASE - MECHANICAL OUTLINE**

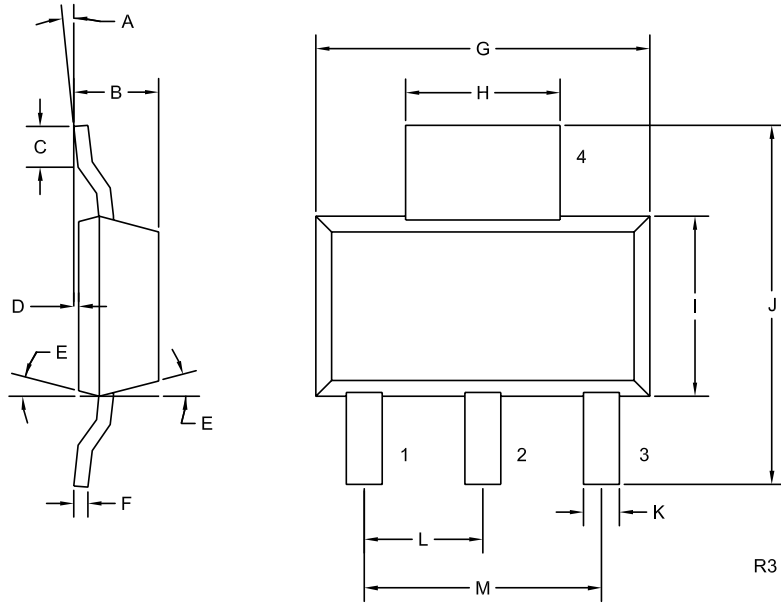

**LEAD CODE:**

- 1) BASE
- 2) COLLECTOR
- 3) EMITTER
- 4) COLLECTOR

**MARKING CODE:**

**FULL PART NUMBER**

SYMBOL	DIMENSIONS			
	INCHES		MILLIMETERS	
	MIN	MAX	MIN	MAX
A	0°	10°	0°	10°
B	0.059	0.071	1.50	1.80
C	0.018	---	0.45	---
D	0.000	0.004	0.00	0.10
E	15°		15°	
F	0.009	0.014	0.23	0.35
G	0.248	0.264	6.30	6.70
H	0.114	0.122	2.90	3.10
I	0.130	0.146	3.30	3.70
J	0.264	0.287	6.70	7.30
K	0.024	0.033	0.60	0.85
L	0.091		2.30	
M	0.181		4.60	

SOT-223 (REV: R3)

R3 (17-June 2004)