

D1019UK

METAL GATE RF SILICON FET

MECHANICAL DATA

**GOLD METALLISED
MULTI-PURPOSE SILICON
DMOS RF FET
20W – 28V – 175MHz
SINGLE ENDED**

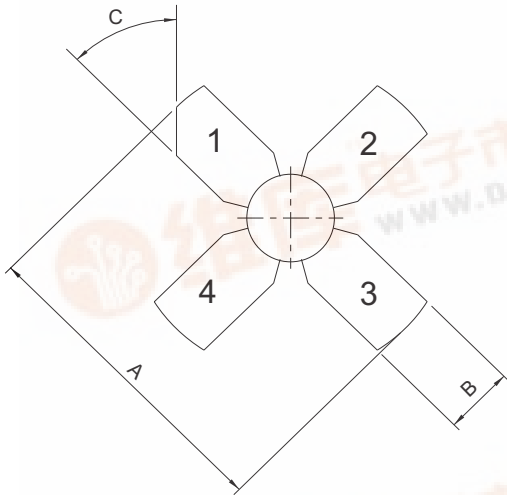

FEATURES

- SIMPLIFIED AMPLIFIER DESIGN
- SUITABLE FOR BROAD BAND APPLICATIONS
- LOW C_{rss}
- SIMPLE BIAS CIRCUITS
- LOW NOISE
- HIGH GAIN – 16 dB MINIMUM

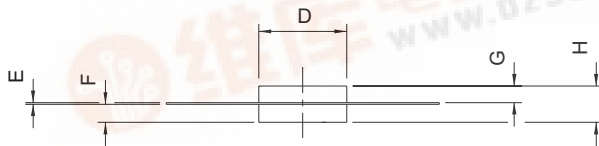

PIN 1 DRAIN PIN 2 SOURCE
PIN 3 GATE PIN 4 SOURCE

DIM	mm	Tol.	Inches	Tol.
A	26.16	0.13	1.030	0.015
B	5.72	0.13	0.225	0.005
C	45°	5°	45°	5°
D	7.11	0.13	0.280	0.005
E	0.13	0.02	0.005	0.001
F	1.52	0.13	0.55	0.005
G	0.43	0.20	0.060	0.008
H	7.67	REF	0.120	REF

APPLICATIONS

- HF/VHF/UHF COMMUNICATIONS
from 1 MHz to 175 MHz

ABSOLUTE MAXIMUM RATINGS ($T_{case} = 25^{\circ}C$ unless otherwise stated)

P_D	Power Dissipation	50W
BV_{DSS}	Drain – Source Breakdown Voltage	70V
BV_{GSS}	Gate – Source Breakdown Voltage	$\pm 20V$
$I_{D(sat)}$	Drain Current	5A
T_{stg}	Storage Temperature	-65 to 150°C
	Maximum Operating Junction Temperature	200°C



ELECTRICAL CHARACTERISTICS (T_{case} = 25°C unless otherwise stated)

Parameter	Test Conditions	Min.	Typ.	Max.	Unit
BV _{DSS} Drain–Source Breakdown Voltage	V _{GS} = 0 I _D = 100mA	70			V
I _{DSS} Zero Gate Voltage Drain Current	V _{DS} = 28V V _{GS} = 0			1	mA
I _{GSS} Gate Leakage Current	V _{GS} = 20V V _{DS} = 0			1	μA
V _{GS(th)} Gate Threshold Voltage*	I _D = 10mA V _{DS} = V _{GS}	1		7	V
g _{fs} Forward Transconductance*	V _{DS} = 10V I _D = 1A	0.8			S
G _{PS} Common Source Power Gain	P _O = 20W	16			dB
η Drain Efficiency	V _{DS} = 28V I _{DQ} = 0.1A	50			%
VSWR Load Mismatch Tolerance	f = 175MHz	20:1			—
C _{iss} Input Capacitance	V _{DS} = 28V V _{GS} = -5V f = 1MHz			60	pF
C _{oss} Output Capacitance	V _{DS} = 28V V _{GS} = 0 f = 1MHz			30	pF
C _{rss} Reverse Transfer Capacitance	V _{DS} = 28V V _{GS} = 0 f = 1MHz			2.5	pF

* Pulse Test: Pulse Duration = 300 μs , Duty Cycle ≤ 2%

HAZARDOUS MATERIAL WARNING

The ceramic portion of the device between leads and metal flange is beryllium oxide. Beryllium oxide dust is highly toxic and care must be taken during handling and mounting to avoid damage to this area.

THESE DEVICES MUST NEVER BE THROWN AWAY WITH GENERAL INDUSTRIAL OR DOMESTIC WASTE.

THERMAL DATA

R _{THj-case}	Thermal Resistance Junction – Case	Max. 3.5°C / W
-----------------------	------------------------------------	----------------

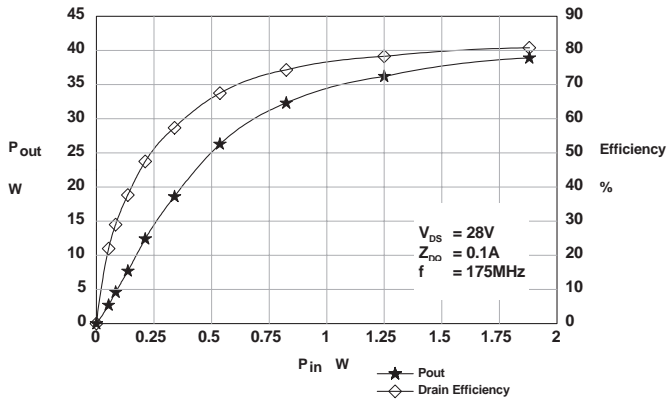

Figure 1 – Power Output and Efficiency vs. Power Input.

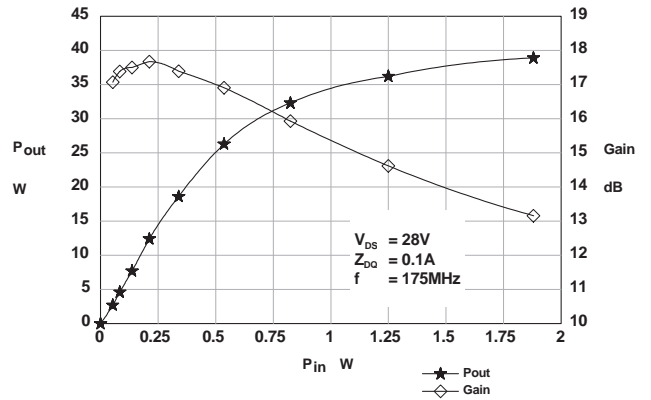

Figure 2 – Power Output & Gain vs. Power Input.

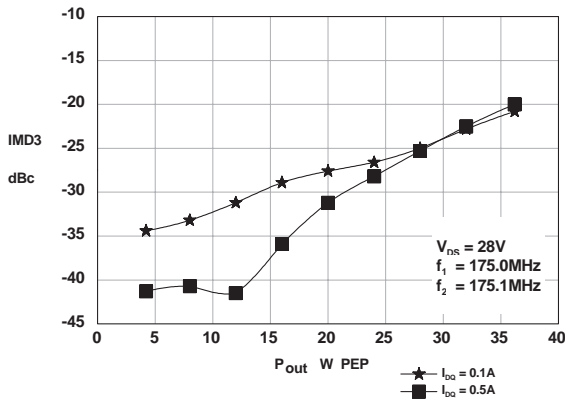

Figure 3 – IMD vs. Output Power.

D1019UK OPTIMUM SOURCE AND LOAD IMPEDANCE

Frequency MHz	Z _S Ω	Z _L Ω
175MHz	5 + j14	12 - j14

Typical S Parameters

! V_{DS} = 28V, I_{DQ} = 0.1A
MHz S MA R 50

!Freq MHz	S11		S21		S12		S22	
	mag	ang	mag	ang	mag	ang	mag	ang
50	0.780	-116	18	112	0.034	25	0.642	-85
100	0.775	-135	9.312	85	0.030	11	0.577	-103
150	0.795	-149	6.077	68	0.022	14	0.613	-116
200	0.826	-159	4.193	53	0.017	44	0.669	-128
250	0.853	-169	3.216	43	0.023	74	0.715	-139
300	0.878	-179	2.566	35	0.039	89	0.759	-150
350	0.903	171	1.991	23	0.052	86	0.801	-161
400	0.923	161	1.655	18	0.070	84	0.839	-173
450	0.944	151	1.322	9	0.080	80	0.878	177
500	0.963	142	1.121	4	0.098	76	0.914	167
550	0.978	136	0.899	-2	0.108	72	0.945	159
600	0.985	131	0.762	-7	0.119	66	0.966	153

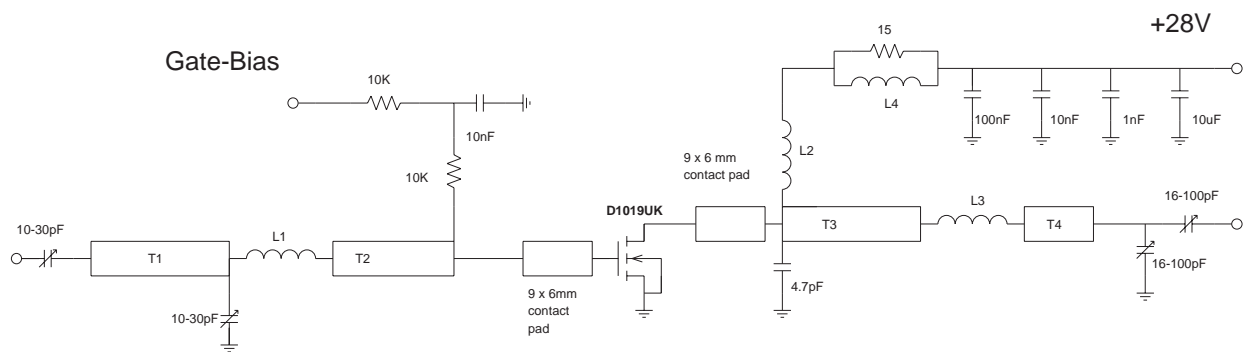

D1019UK 175MHz TEST FIXTURE

Substrate 1.6mm PTFE/glass, Er=2.5
All microstrip lines W=4.4mm

T1	10mm	L1	1.5 turns 22swg enamelled copper wire, 6mm i.d.
T2	13mm	L2	10 turns 19swg enamelled copper wire, 6mm i.d.
T3	12mm	L3	1.5 turns 22swg enamelled copper wire, 6mm i.d.
T4	4mm	L4	13.5 turns 19swg enamelled copper wire on Siemens B64920A618X830 ferrite core