

D2085UK

MECHANICAL DATA

TetraFET
120W – 28V – 0.8GHz

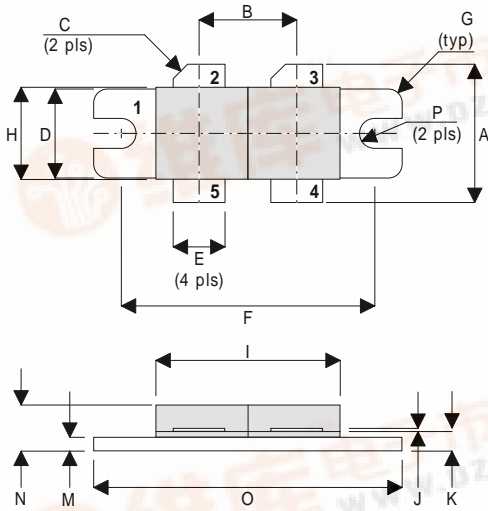

DIM	mm	Tol.	Inches	Tol.
A	19.05	0.50	0.75	0.020
B	10.77	0.13	0.424	0.005
C	45°	5°	45°	5°
D	9.78	0.13	0.385	0.005
E	5.71	0.13	0.225	0.005
F	27.94	0.13	1.100	0.005
G	1.52R	0.13	0.060R	0.005
H	10.16	0.13	0.400	0.005
I	22.22	MAX	0.875	MAX
J	0.13	0.02	0.005	0.001
K	2.72	0.13	0.107	0.005
M	1.70	0.13	0.067	0.005
N	5.08	0.50	0.200	0.020
O	34.03	0.13	1.340	0.005
P	1.57R	0.08	0.062R	0.003

PIN 1 SOURCE (COMMON) PIN 2 DRAIN 1
 PIN 3 DRAIN 2 PIN 4 GATE 2
 PIN 5 GATE 1

ELECTRICAL CHARACTERISTICS (T_{case} = 25°C unless otherwise stated)

Parameter	Test Conditions	Min.	Typ.	Max.	Unit
PER SIDE					
BV _{DSS}	Drain-Source Breakdown Voltage	I = 100mA	65		V
I _{DSS}	Zero Gate Voltage Drain Current	V = 28V		5	mA
I _{GSS}	Gate Leakage Current	V = 20V		1	μA
V _{GS(th)}	Gate Threshold Voltage	I = 10mA	1	7	V
g _m	*	V = 10V I = 4A T = 300μS	4		mhos
C _{iss}	Input Capacitance	V _{DS} = 0V V _{GS} = -5V	215		pF
C _{oss}	Output Capacitance	V = 28V	85		pF
C _{rss}	Reverse Transfer Capacitance	V = 28V	4.5		pF
V _{GS(th)match}	Gate Threshold Matching Voltage Between Sides	I _D = 10mA V _{DS} = V _{GS}		0.1	V
TOTAL DEVICE					
P _O = 120W f = 800MHz V = 28V I _{DQ} = 4A					
Thermal Resistance = 0.52 °C / W					

HAZARDOUS MATERIAL WARNING

The ceramic portion of the device between leads and metal flange is beryllium oxide. Beryllium oxide dust is highly toxic and care must be taken during handling and mounting to avoid damage to this area.

THESE DEVICES MUST NEVER BE THROWN AWAY WITH GENERAL INDUSTRIAL OR DOMESTIC WASTE.

