

SHINDENGEN

General Purpose Rectifiers

SIL Bridges

D20XB80

800V 20A

FEATURES

- Thin Single In-Line Package
- High current capacity with Small Package
- High IFSM
- Superior Thermal Conductivity

APPLICATION

- Switching power supply
- Home Appliances, Office Equipment
- Factory Automation, Inverter

OUTLINE DIMENSIONS

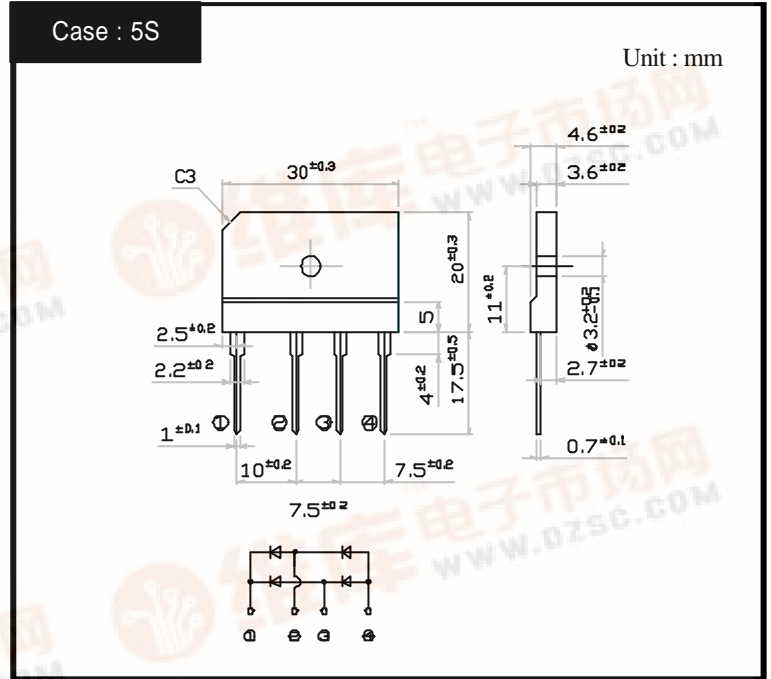

RATINGS

Absolute Maximum Ratings (If not specified Tc=25)

Item	Symbol	Conditions	Ratings	Unit
Storage Temperature	Tstg		-40 ~ 150	
Operating Junction Temperature	Tj		150	
Maximum Reverse Voltage	V _{RM}		800	V
Average Rectified Forward Current	I _O	50Hz sine wave, R-load With heatsink Tc=87	20	A
		50Hz sine wave, R-load Without heatsink Ta=25	3.5	
Peak Surge Forward Current	I _{FSM}	50Hz sine wave, Non-repetitive 1cycle peak value, Tj=25	240	A
Current Squared Time	I ² t	1ms t < 10ms Tj=25	200	A ² s
Dielectric Strength	Vdis	Terminals to case, AC 1 minute	2.5	kV
Mounting Torque	TOR	(Recommended torque 0.5N·m)	0.8	N·m

Electrical Characteristics (If not specified Tc=25)

Item	Symbol	Conditions	Ratings	Unit
Forward Voltage	V _F	I _F =10A, Pulse measurement, Rating of per diode	Max.1.1	V
Reverse Current	I _R	V _R =V _{RM} , Pulse measurement, Rating of per diode	Max.10	μA
Thermal Resistance	j-c	junction to case With heatsink	Max.1.5	/W
	j-l	junction to lead Without heatsink	Max.5	
	j-a	junction to ambient Without heatsink	Max.22	



D20XBx

Forward Voltage

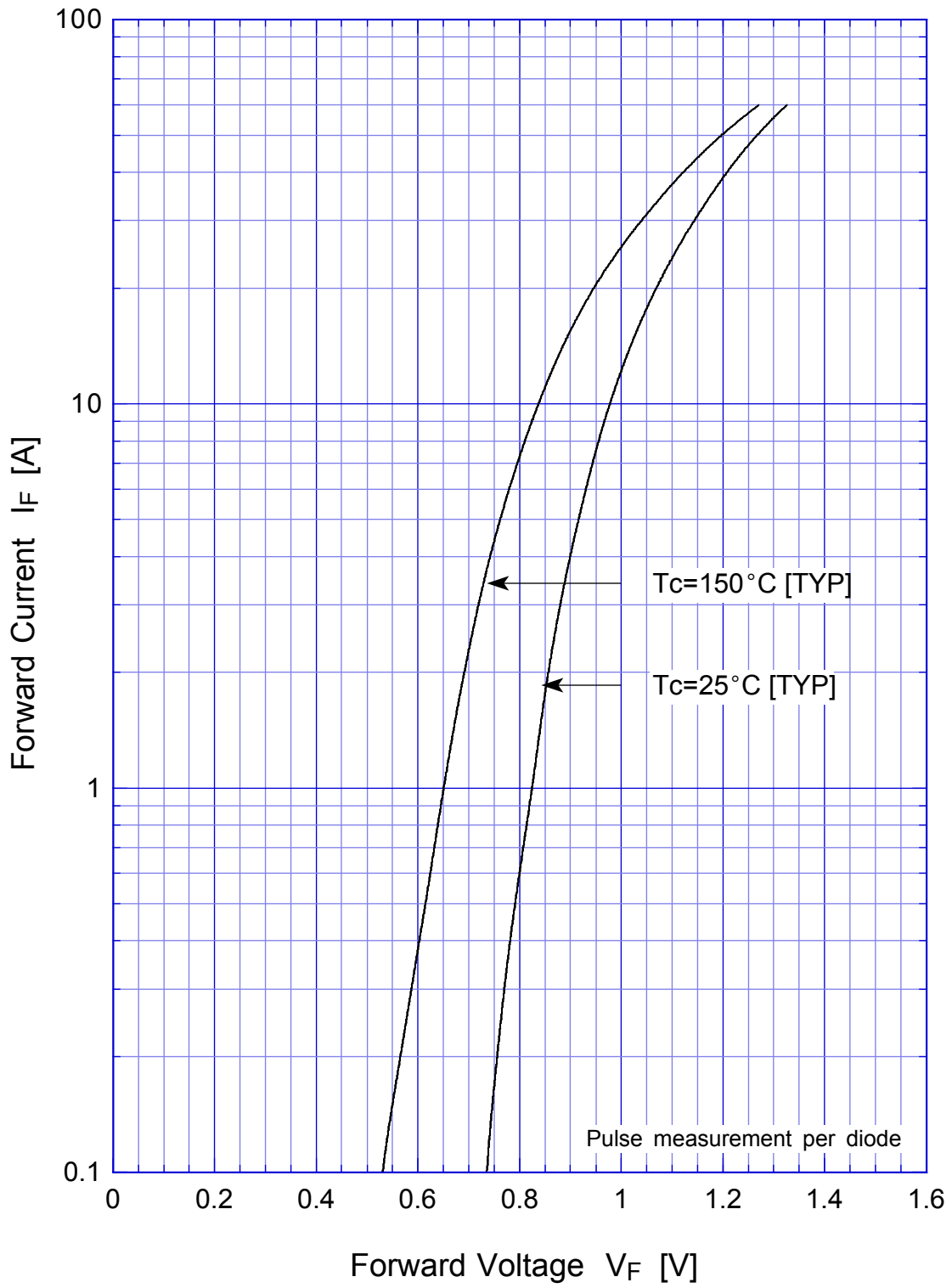

D20XBx Forward Power Dissipation

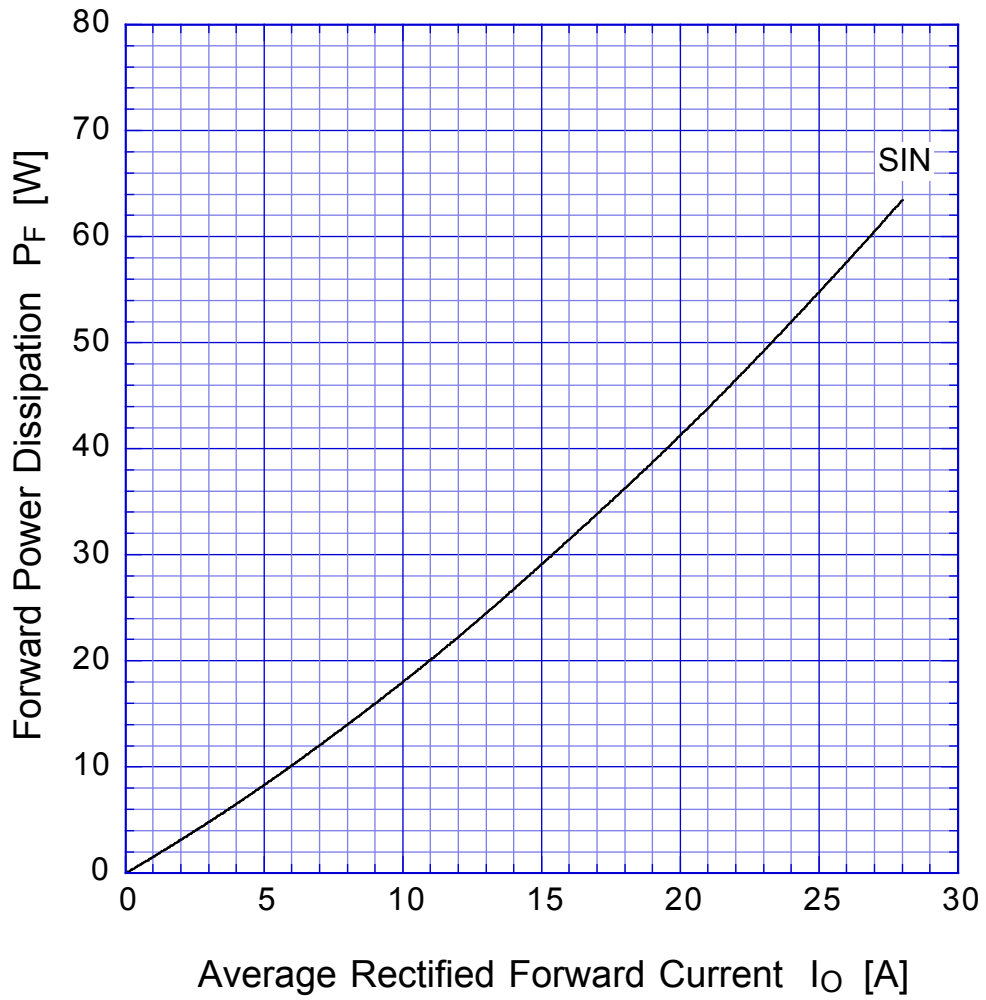

$T_j = 150^\circ\text{C}$
Sine wave

D20XBx

Derating Curve

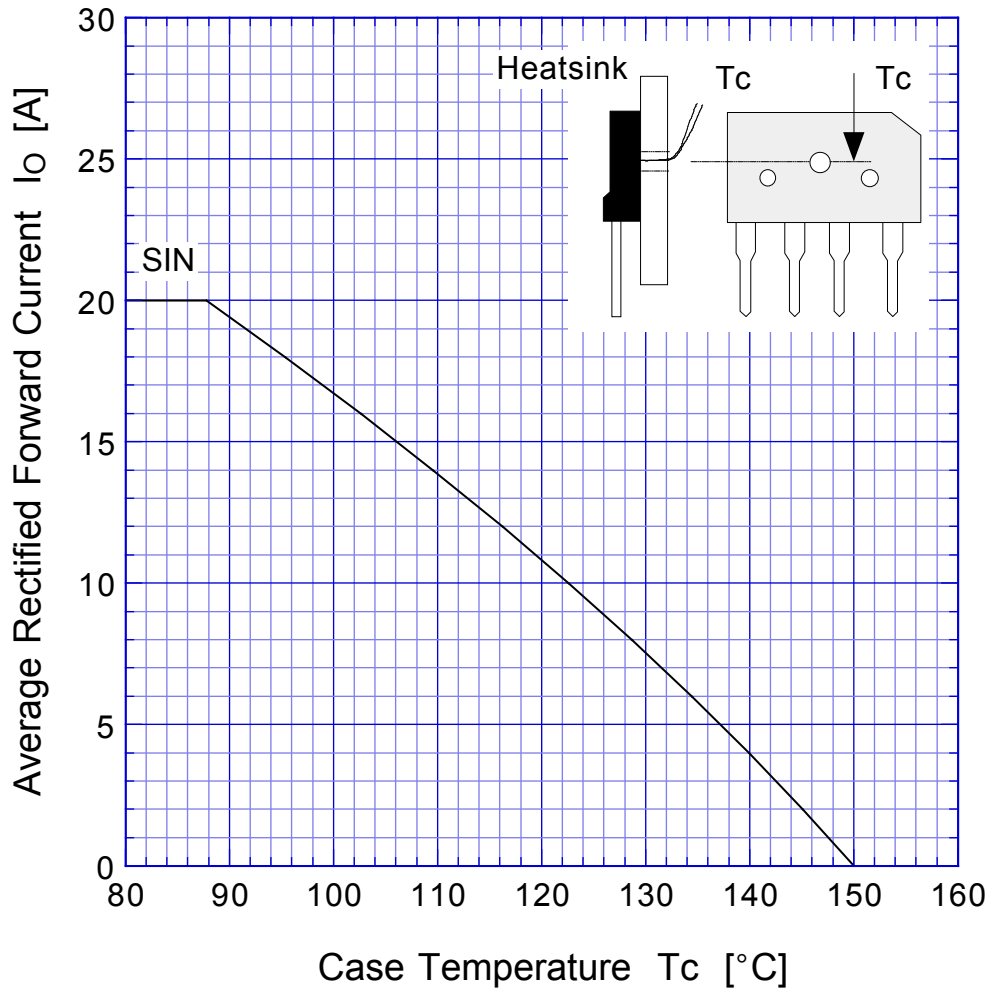

Sine wave
R-load
with heatsink

D20XBx

Derating Curve

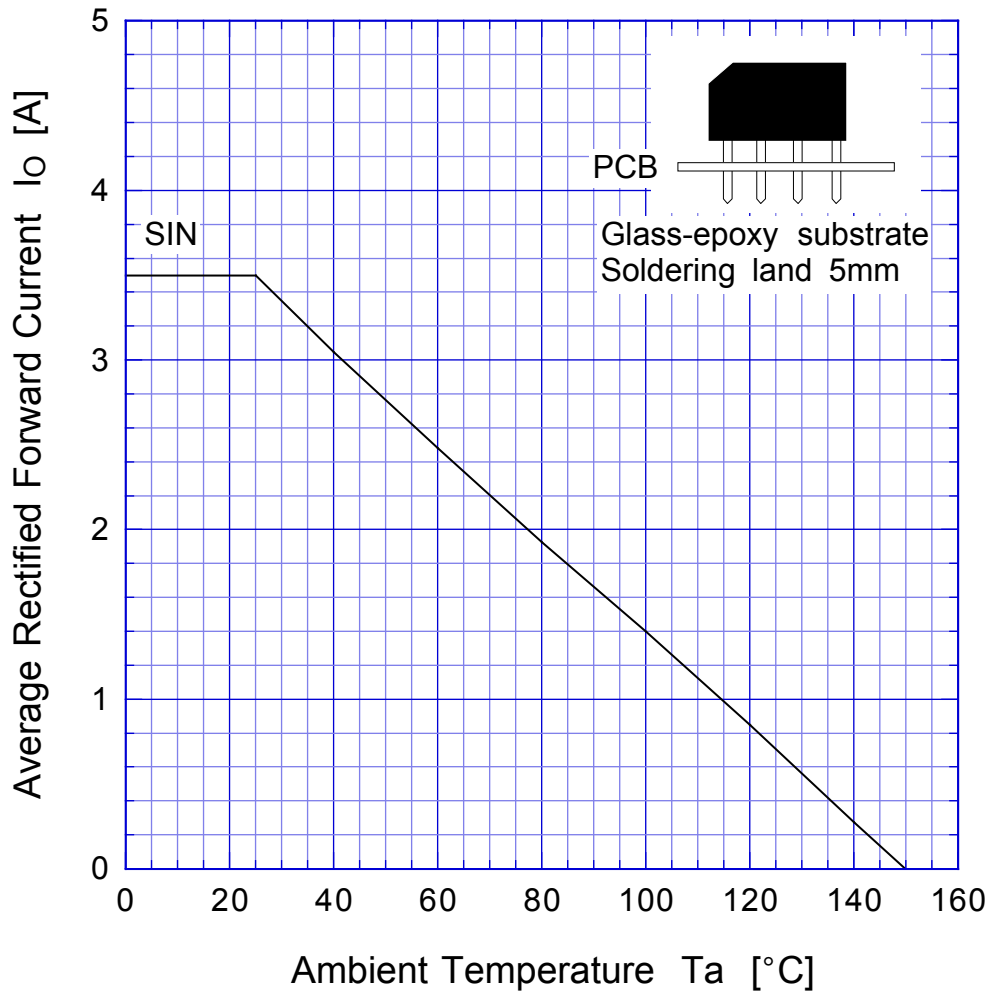

Sine wave
R-load
Free in air

D20XBx

Peak Surge Forward Capability

