

SHINDENGEN

Super Fast Recovery Rectifiers

Single

D2FL20U

200V 1.5A

FEATURES

- Small SMT
- Low noise
- trr35ns

APPLICATION

- Switching power supply
- DC/DC converter
- Free Wheel
- Home Appliances, Office Equipment
- Telecommunication, Factory Automation

OUTLINE DIMENSIONS

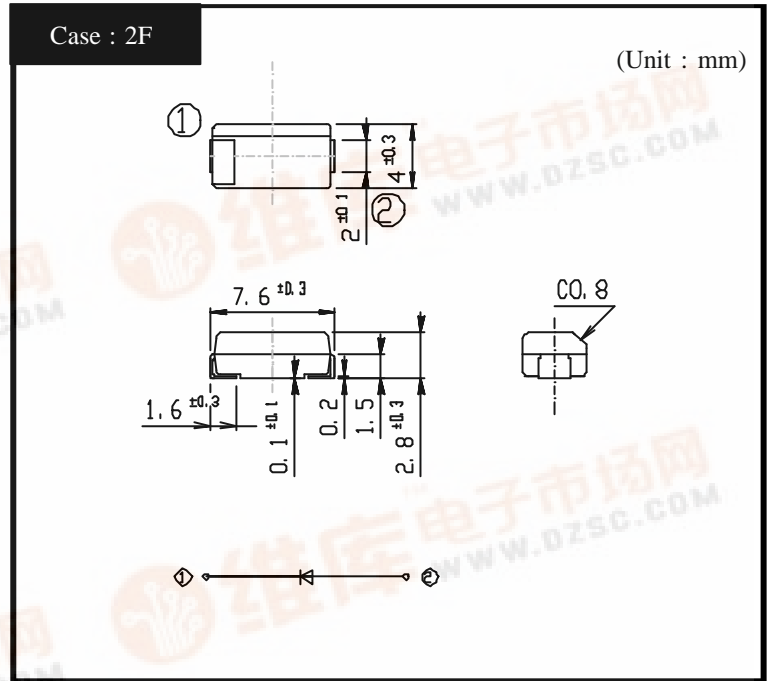

RATINGS

Absolute Maximum Ratings (If not specified Tl=25)

Item	Symbol	Conditions	Ratings	Unit
Storage Temperature	Tstg		-55 ~ 150	
Operating Junction Temperature	Tj		150	
Maximum Reverse Voltage	V _{RM}		200	V
Average Rectified Forward Current	I _O	50Hz sine wave, R-load, Ta=25 On alumina substrate	1.5	A
		50Hz sine wave, R-load, Ta=25 On glass-epoxy substrate	1.2	
Peak Surge Forward Current	I _{FSM}	50Hz sine wave, Non-repetitive 1 cycle peak value, Tj=25	50	A

Electrical Characteristics (If not specified Tl=25)

Item	Symbol	Conditions	Ratings	Unit
Forward Voltage	V _F	I _F =1.5A, Pulse measurement	Max.0.98	V
Reverse Current	I _R	V _R =V _{RM} , Pulse measurement	Max.10	μ A
Reverse Recovery Time	trr	I _F =0.5A, I _R =1A	Max.35	ns
Thermal Resistance	j	junction to lead	Max.24	/W
		junction to ambient, On alumina substrate	Max.90	
		junction to ambient, On glass-epoxy substrate	Max.120	



D2FL20U

Forward Voltage

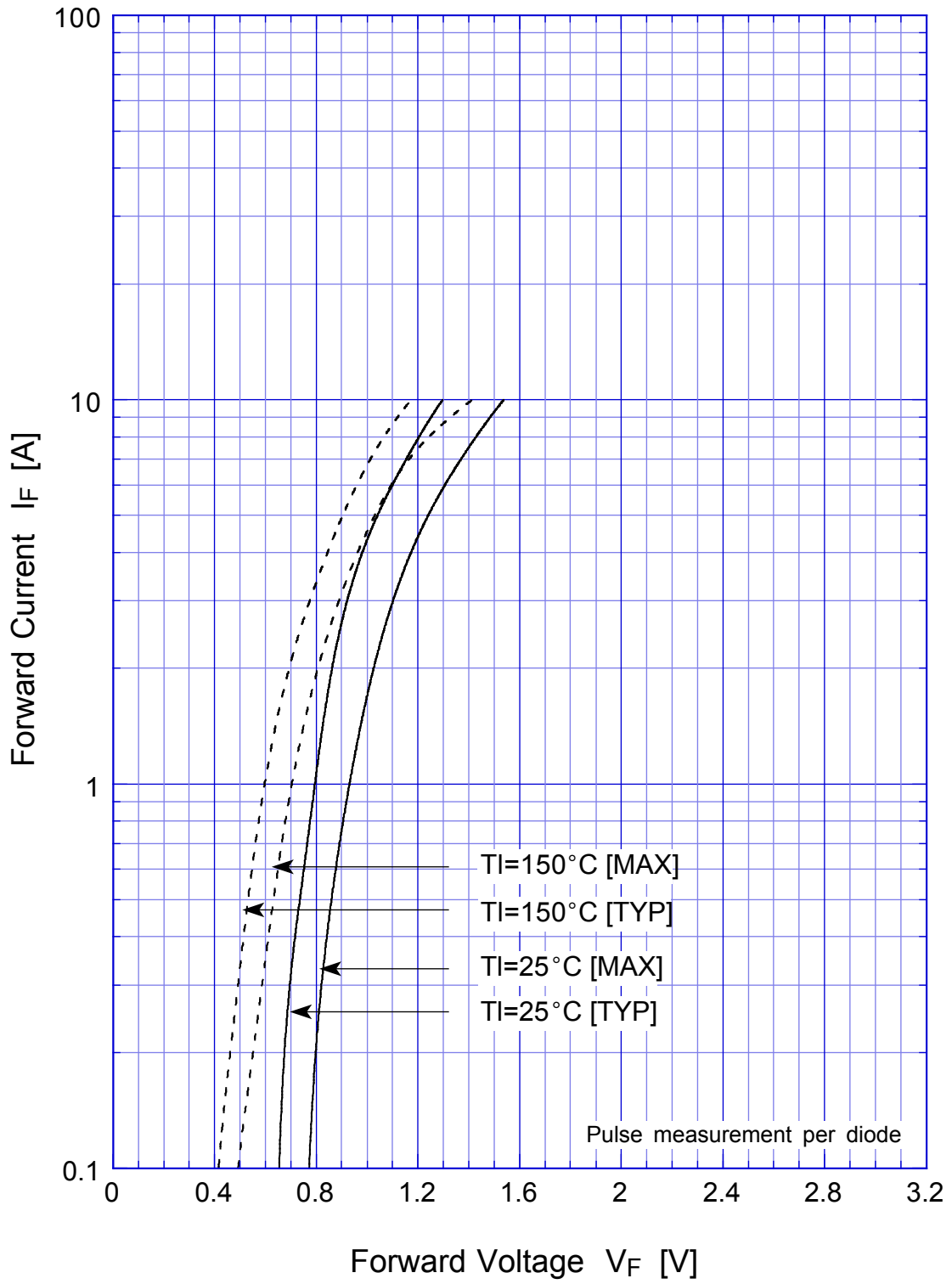

D2FL20U Forward Power Dissipation

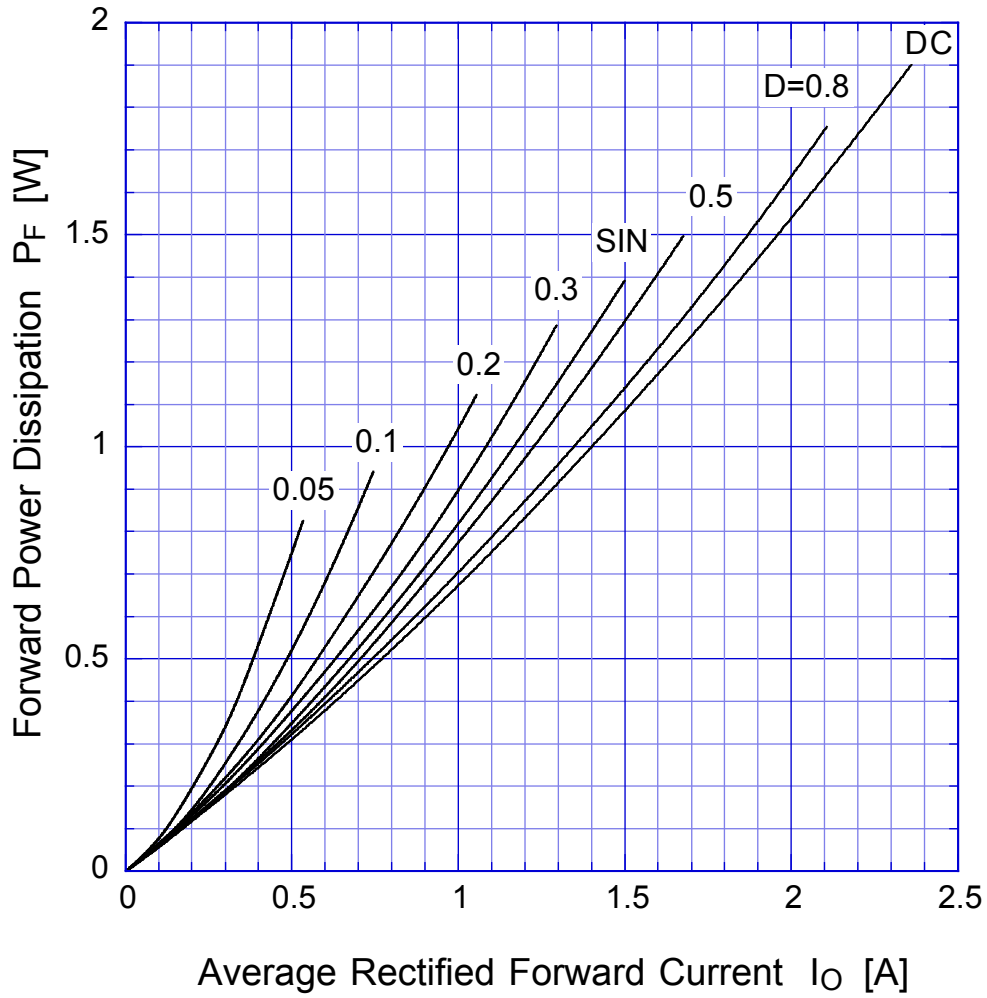

$T_j = T_{jmax}$

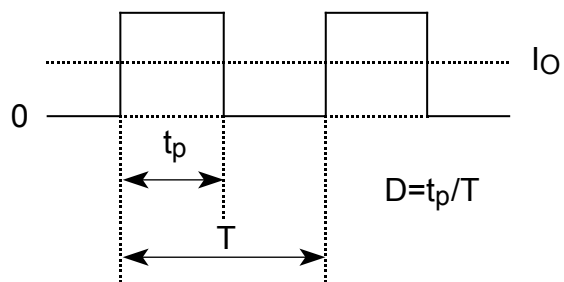

D2FL20U

Derating Curve

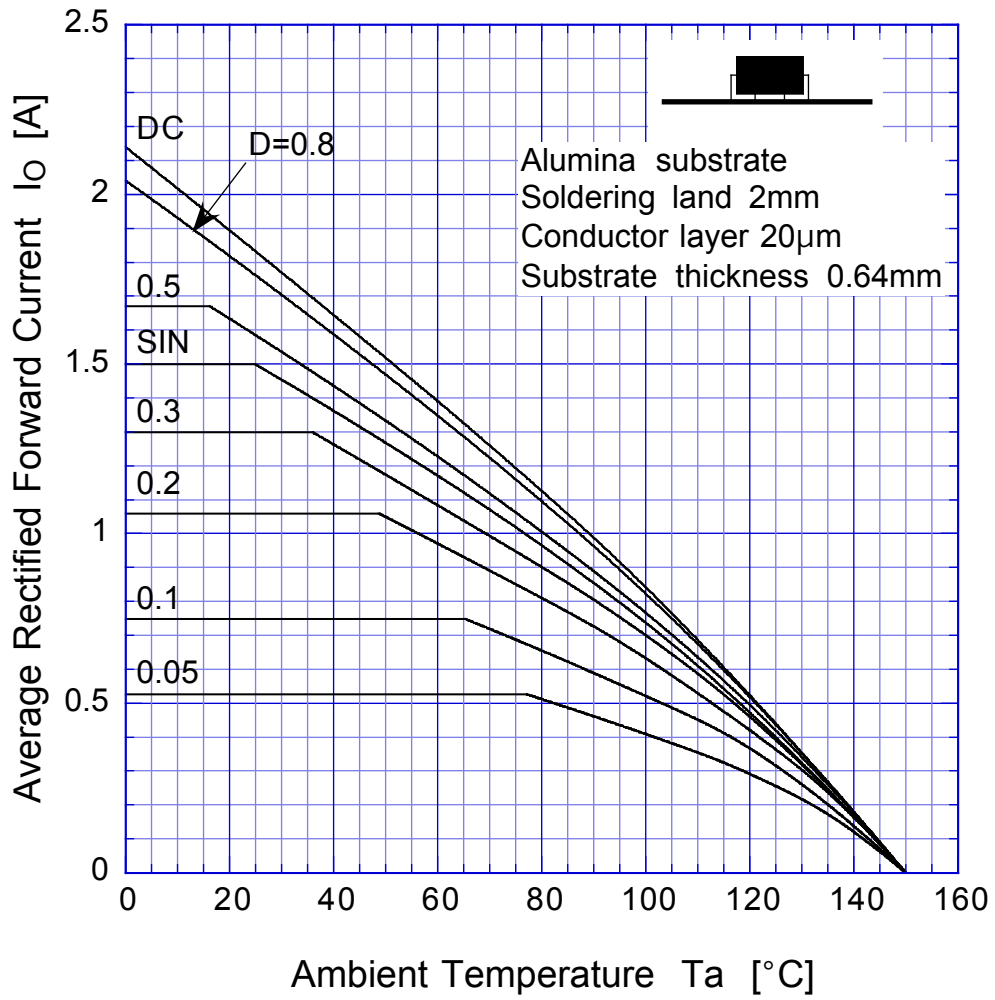

$$V_R = V_{RM}$$

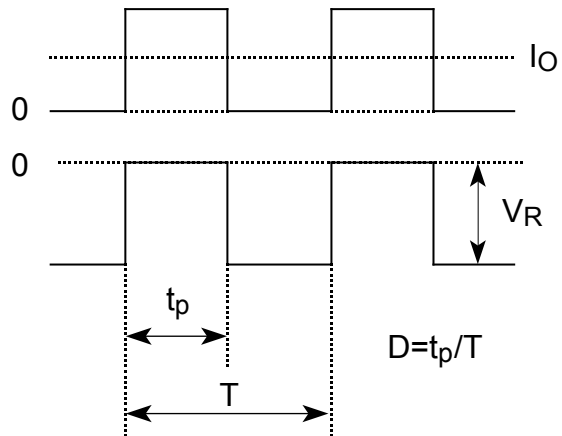

D2FL20U

Derating Curve

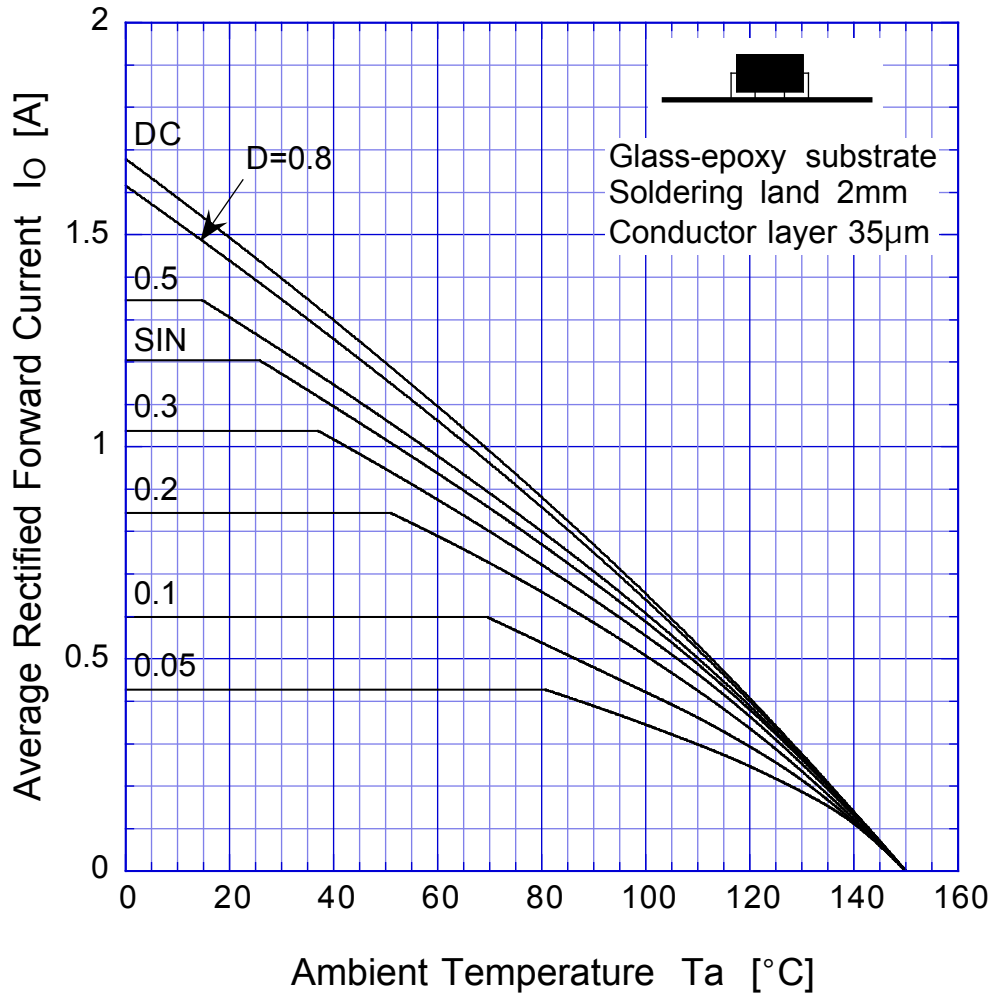

$$V_R = V_{RM}$$

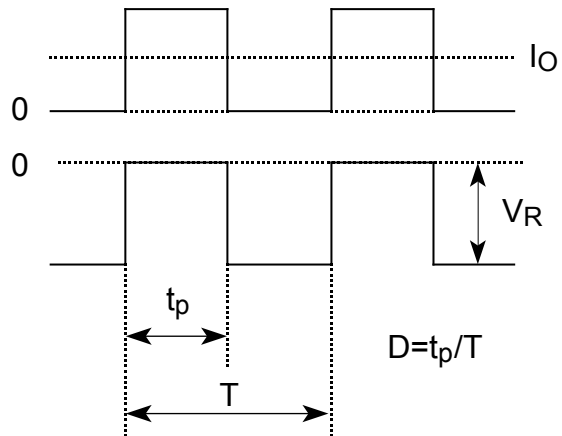

D2FL20U

Peak Surge Forward Capability

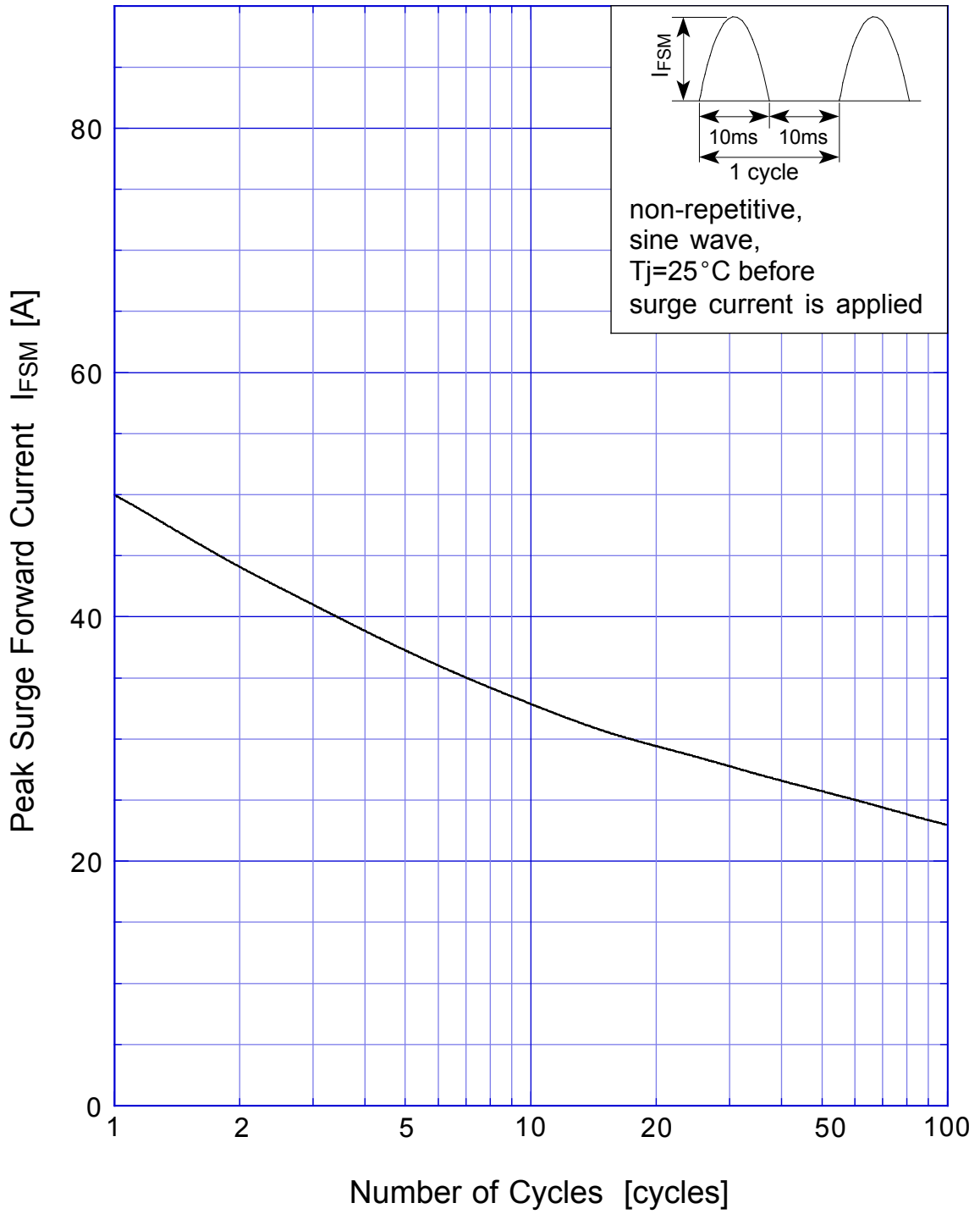

D2FL20U Junction Capacitance

