

SHINDENGEN

Schottky Rectifiers (SBD)

Single

D2S4M

40V 2A

FEATURES

- Tj150
- P_{RRSM} avalanche guaranteed
- 0.8 lead

APPLICATION

- Switching power supply
- DC/DC converter
- Home Appliances, Office Equipment
- Telecommunication

OUTLINE DIMENSIONS

Case : AX078

Unit : mm

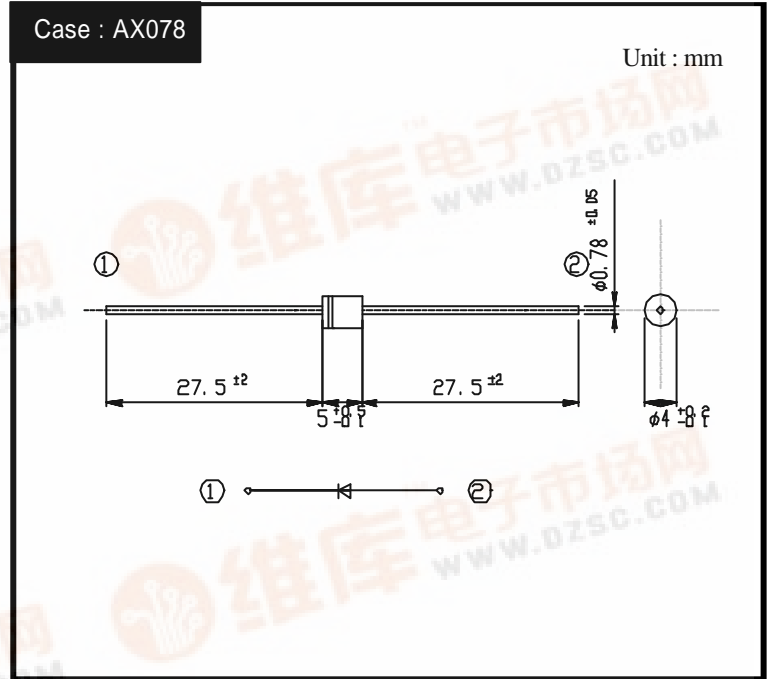

RATINGS

Absolute Maximum Ratings (If not specified Tl=25)

Item	Symbol	Conditions	Ratings	Unit
Storage Temperature	Tstg		-40 ~ 150	
Operating Junction Temperature	Tj		150	
Maximum Reverse Voltage	V _{RM}		40	V
Repetitive Peak Surge Reverse Voltage	V _{RRSM}	Pulse width 0.5ms, duty 1/40	45	V
Average Rectified Forward Current	I _o	50Hz sine wave, R-load Ta=36	1.5	A
		50Hz sine wave, R-load Tl=122	2	
Peak Surge Forward Current	I _{FSM}	50Hz sine wave, Non-repetitive 1 cycle peak value, Tj=25	60	A
Repetitive Peak Surge Reverse Power	P _{RRSM}	Pulse width 10 μs, Tj=25	160	W

Electrical Characteristics (If not specified Tl=25)

Item	Symbol	Conditions	Ratings	Unit
Forward Voltage	V _F	I _F =2A, Pulse measurement	Max.0.55	V
Reverse Current	I _R	V _R =V _{RM} , Pulse measurement	Max.2	mA
Junction Capacitance	C _j	f=1MHz, V _R =10V	Typ.95	pF
Thermal Resistance	j-l	junction to lead	Max.17	/W
	j-a	junction to ambient	Max.105	



D2S4M

Forward Voltage

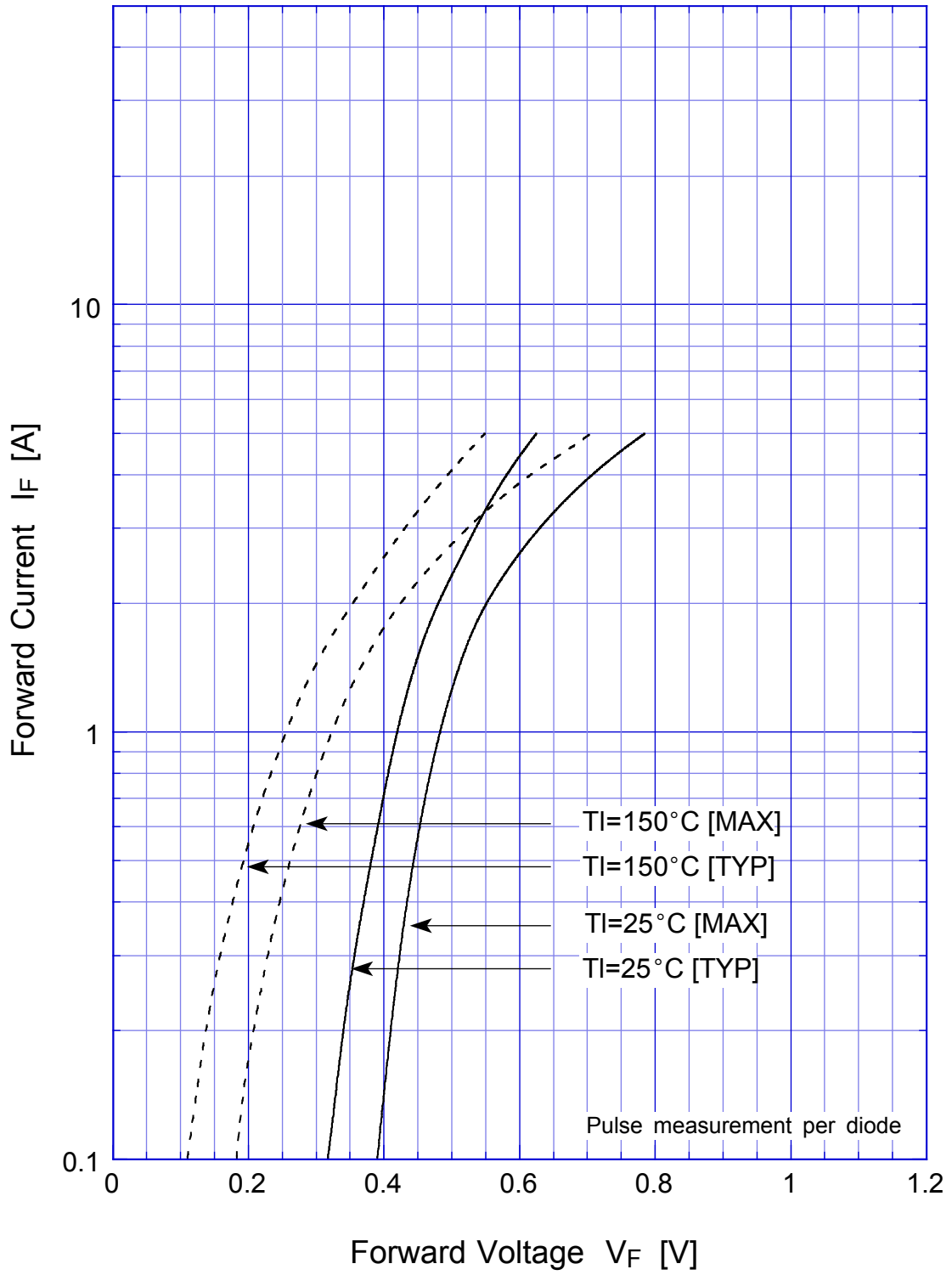

D2S4M Junction Capacitance

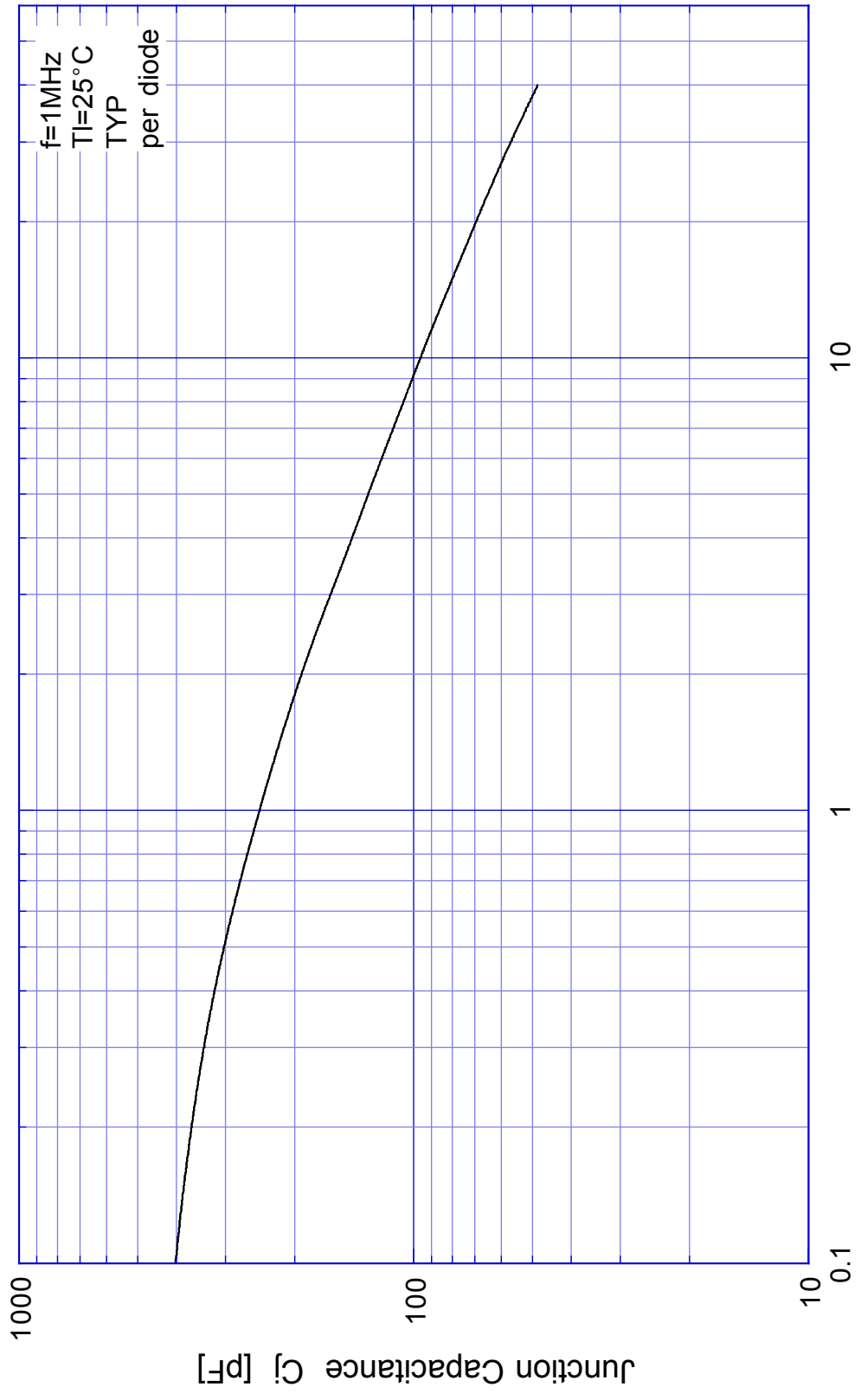

Reverse Voltage V_R [V]

D2S4M

Reverse Current

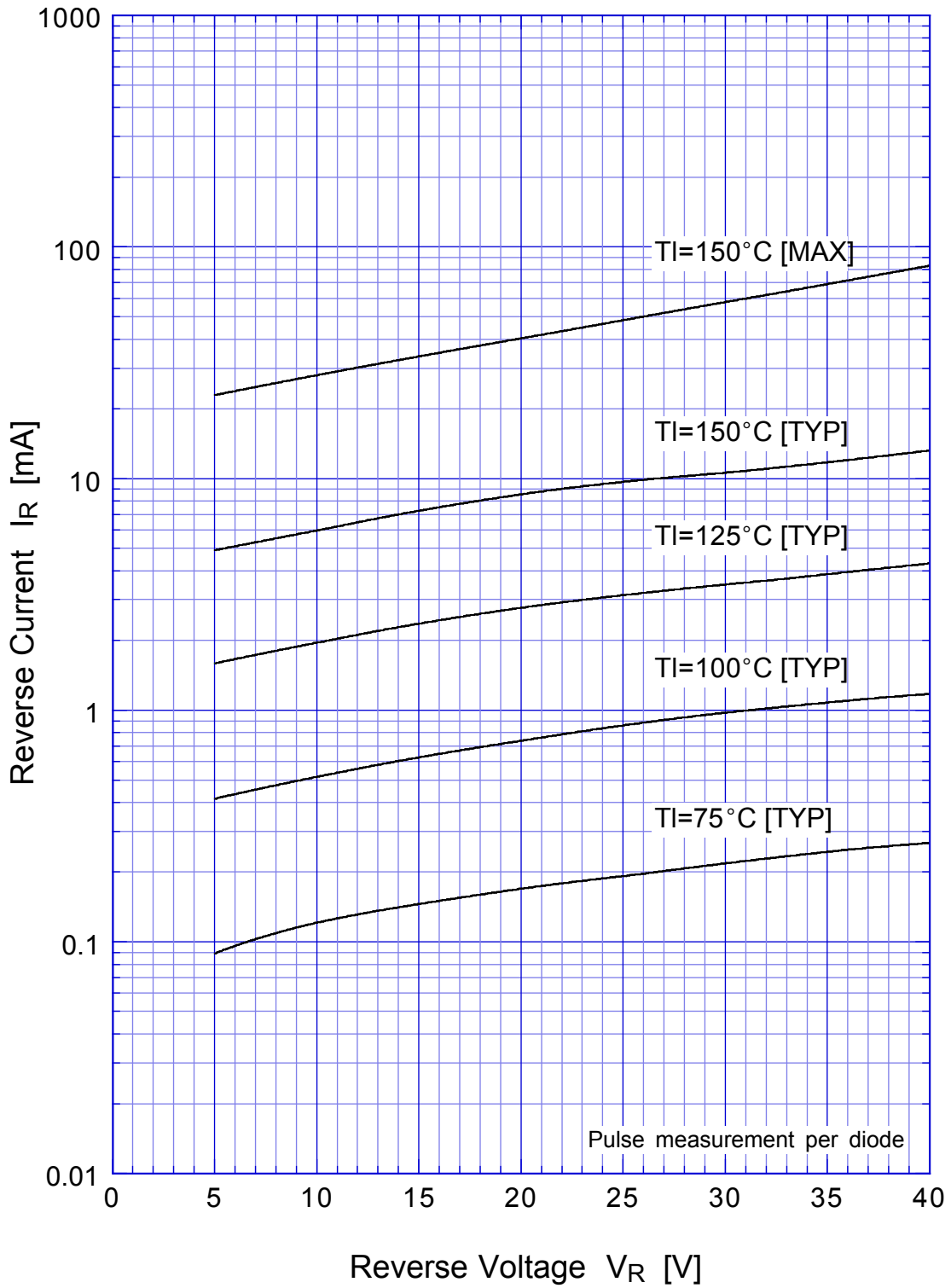

D2S4M

Reverse Power Dissipation

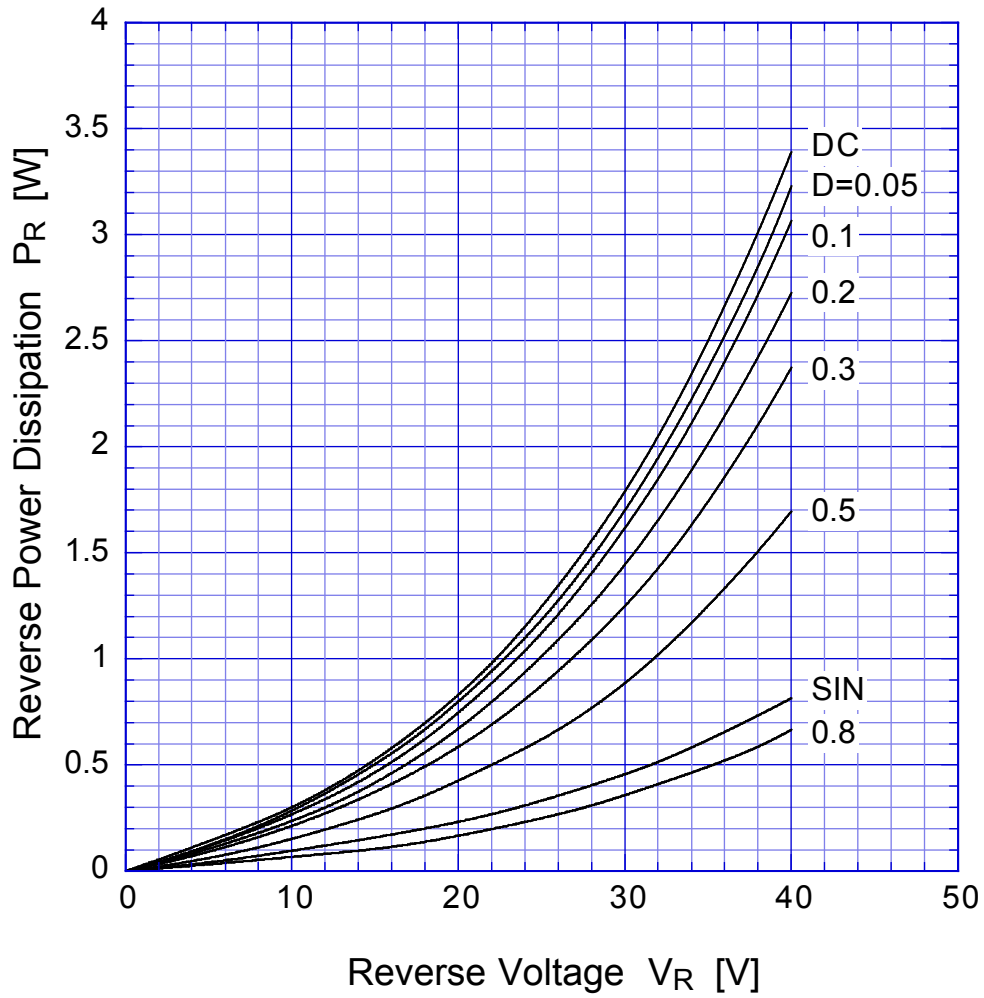

$T_j = 150^\circ\text{C}$

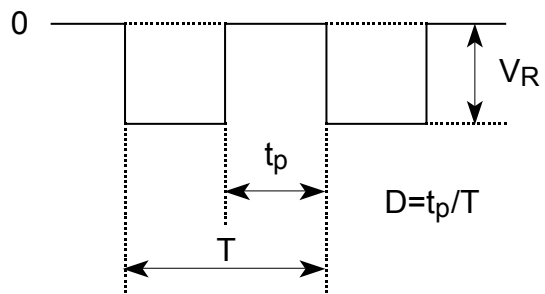

D2S4M

Forward Power Dissipation

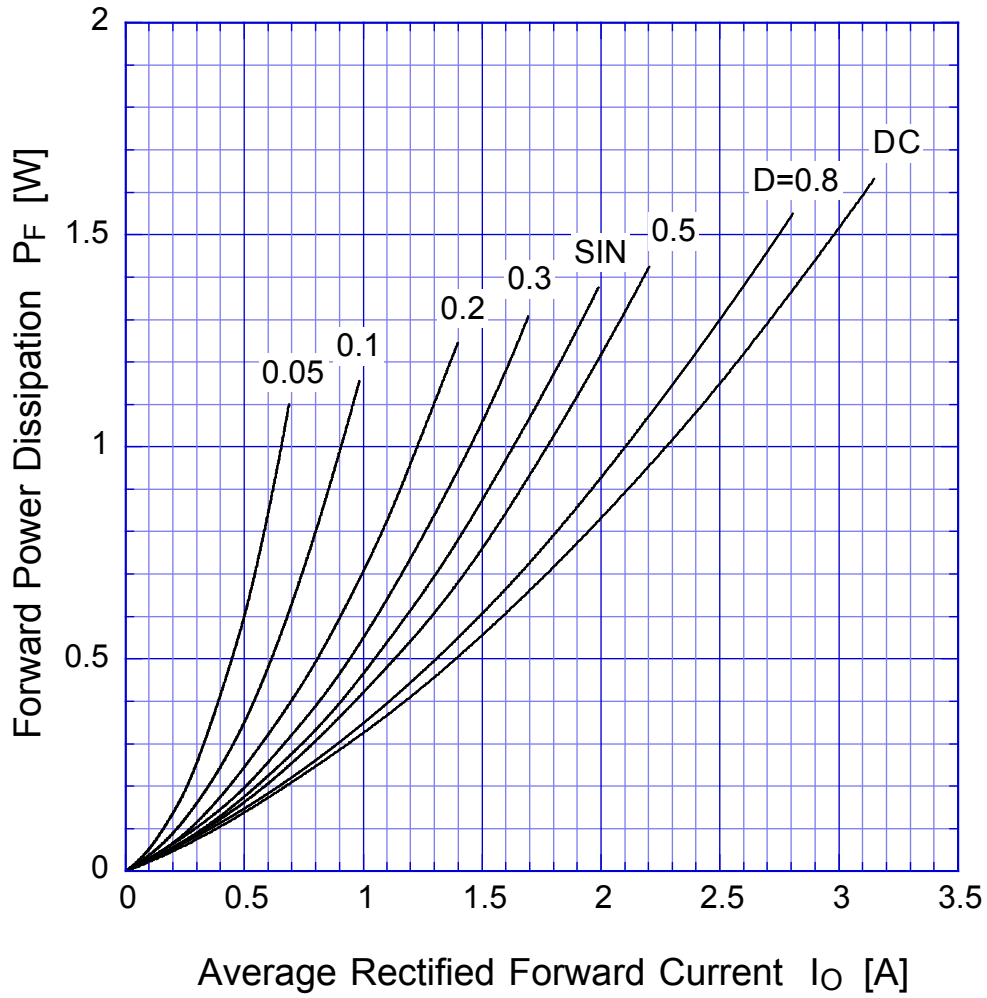

$T_j = 150^\circ\text{C}$

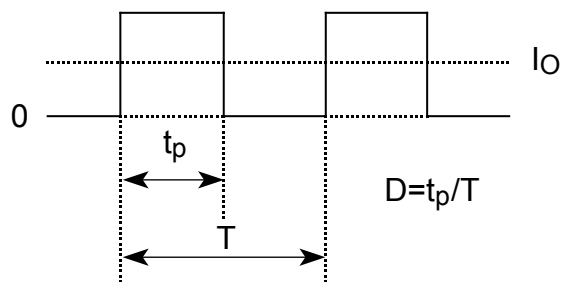

D2S4M

Derating Curve

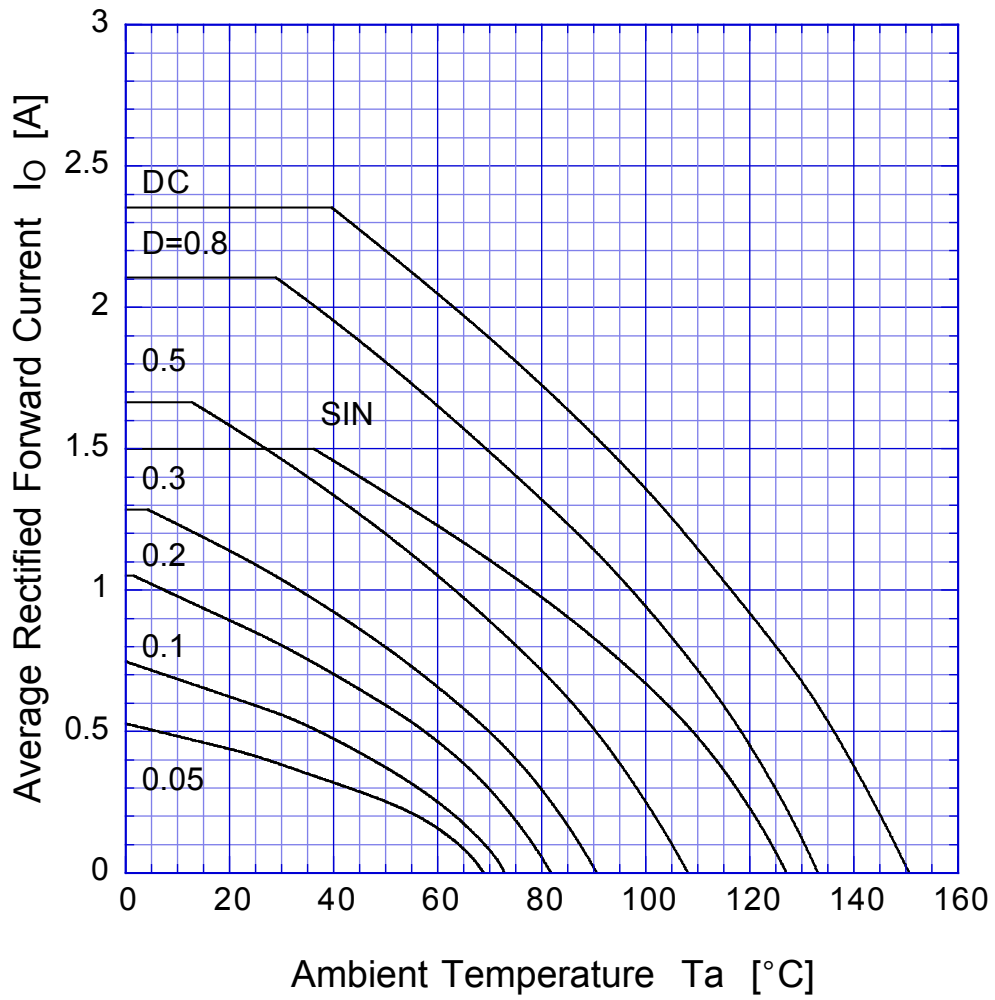

$V_R = 20V$

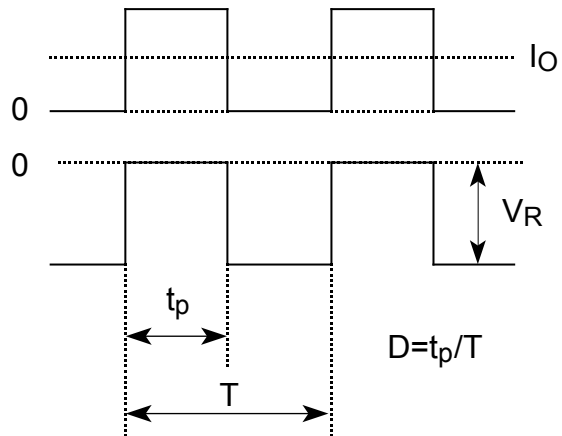

D2S4M

Derating Curve

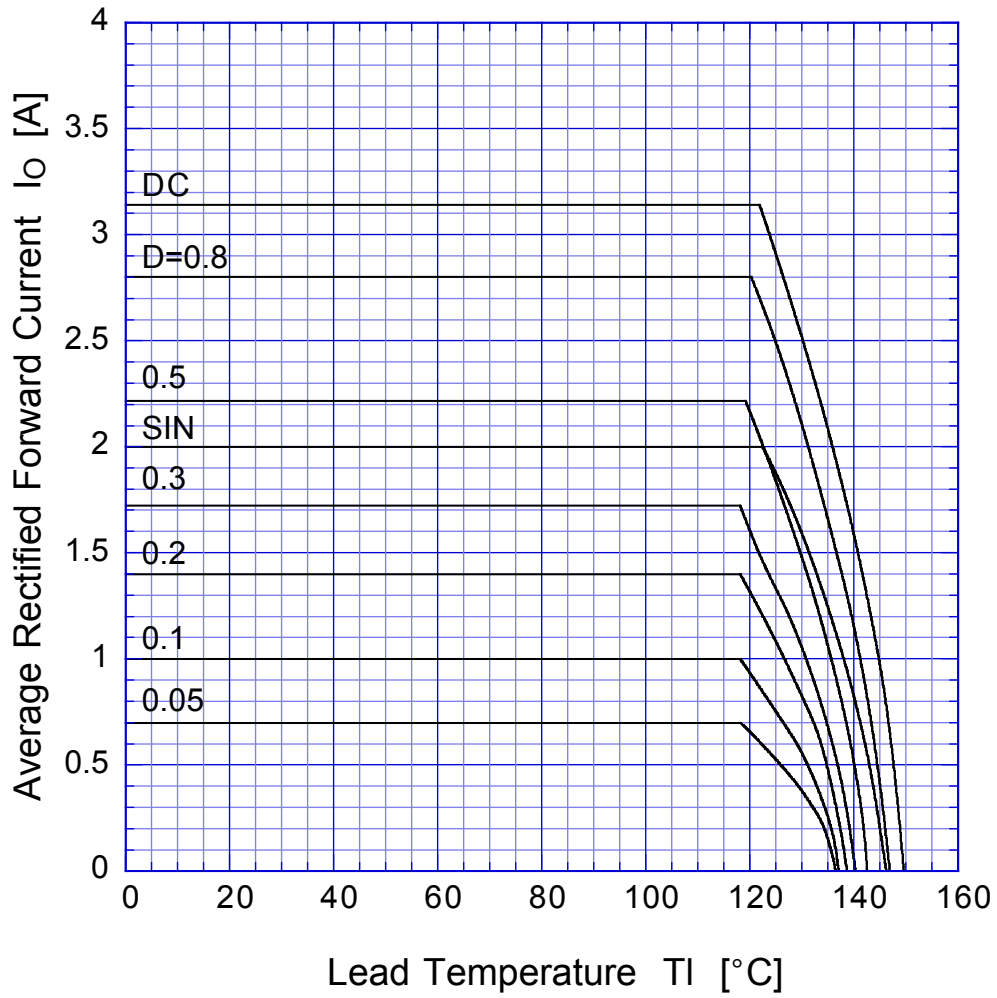

$V_R = 20V$

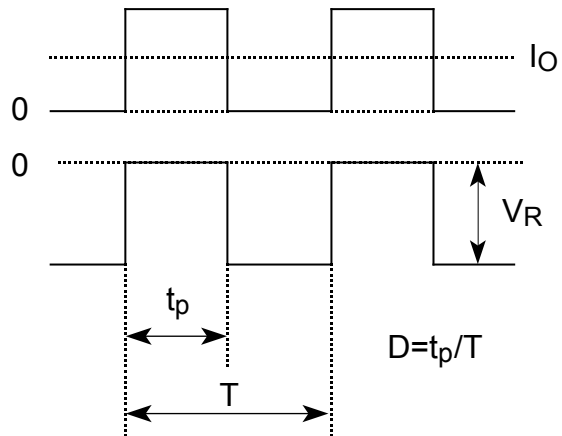

D2S4M

Peak Surge Forward Capability

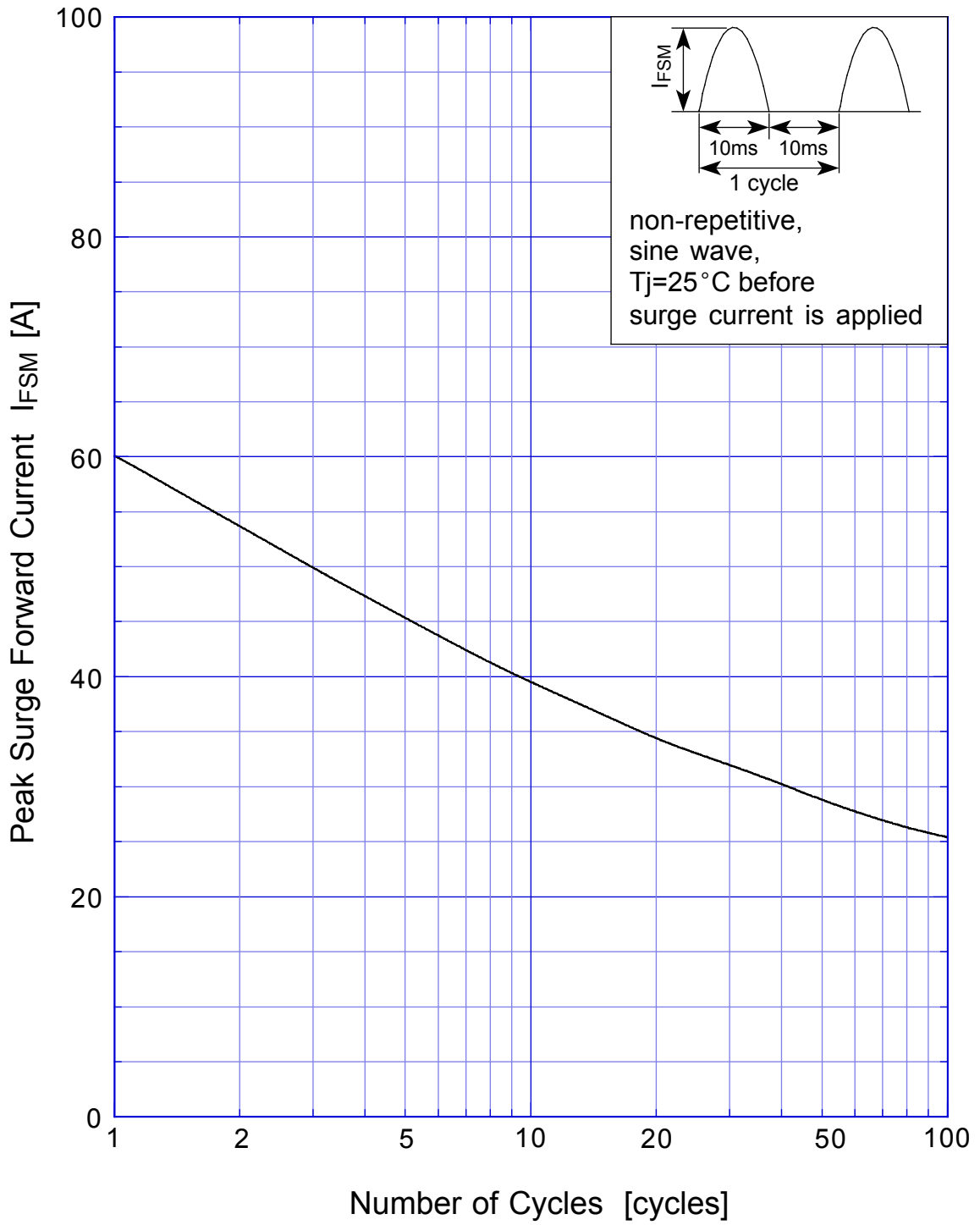

SBD Repetitive Surge Reverse Power Derating Curve

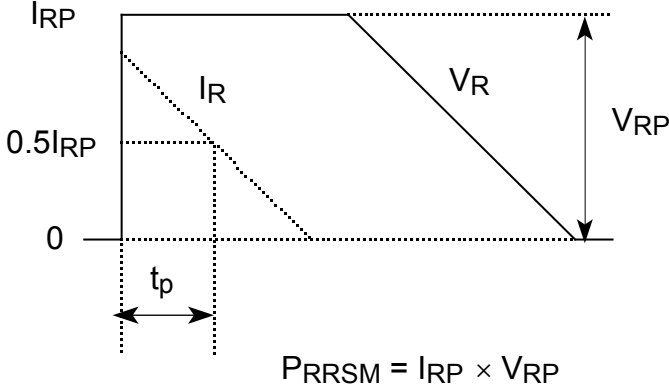
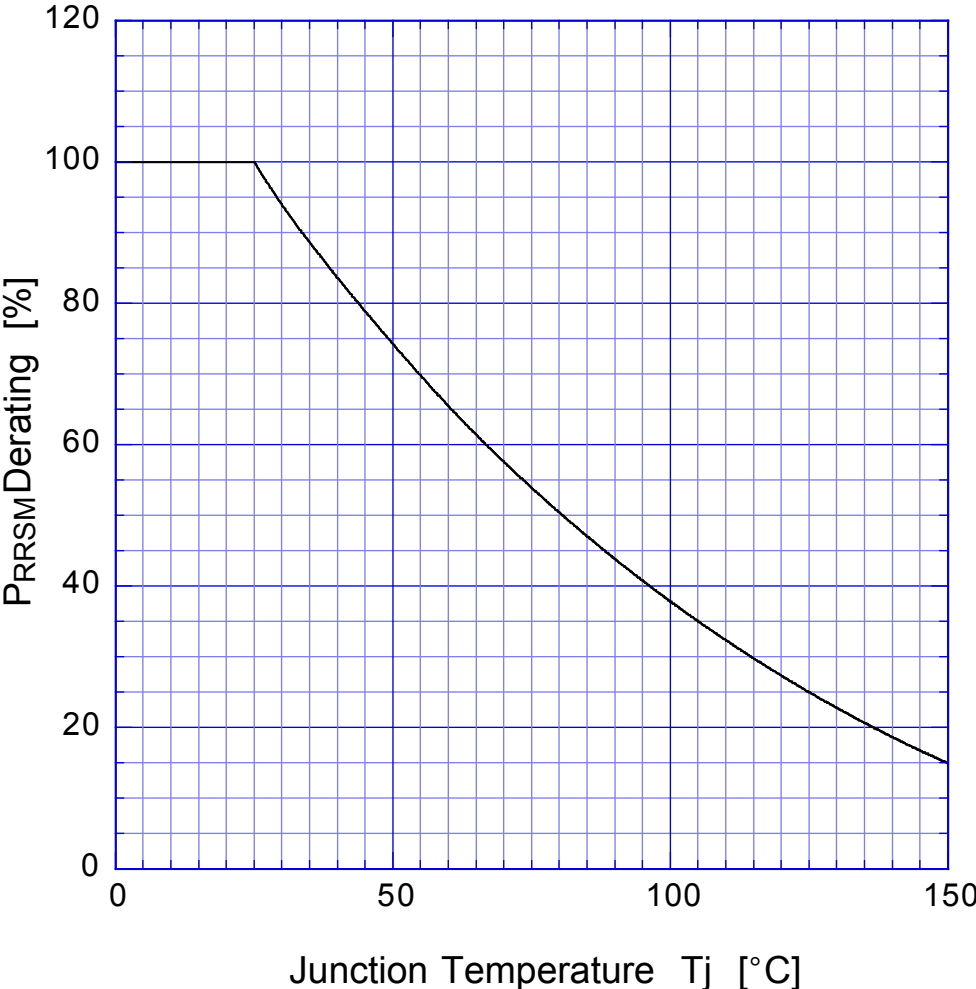

SBD

Repetitive Surge Reverse Power Capability

