

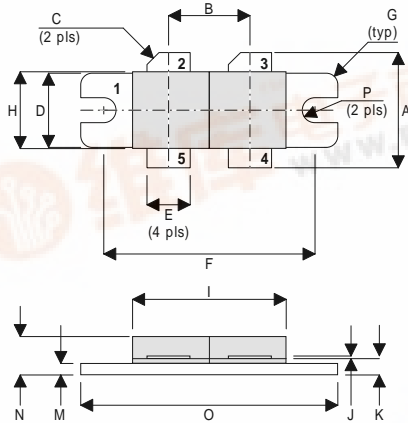

D5028UK

METAL GATE RF SILICON FET

MECHANICAL DATA



DR

PIN 1 SOURCE (COMMON) PIN 2 DRAIN 1
 PIN 3 DRAIN 2 PIN 4 GATE 2
 PIN 5 GATE 1

DIM	Millimetres	Tol.	Inches	Tol.
A	19.05	0.50	0.75	0.020
B	10.77	0.13	0.424	0.005
C	45°	5°	45°	5°
D	9.78	0.13	0.385	0.005
E	5.71	0.13	0.225	0.005
F	27.94	0.13	1.100	0.005
G	1.52R	0.13	0.060R	0.005
H	10.16	0.13	0.400	0.005
I	22.22	MAX	0.875	MAX
J	0.13	0.02	0.005	0.001
K	2.72	0.13	0.107	0.005
M	1.70	0.13	0.067	0.005
N	5.08	0.50	0.200	0.020
O	34.03	0.13	1.340	0.005
P	1.61R	0.08	0.064R	0.003

GOLD METALLISED MULTI-PURPOSE SILICON DMOS RF FET 300W – 50V – 175MHz PUSH-PULL

FEATURES

- SIMPLIFIED AMPLIFIER DESIGN
- SUITABLE FOR BROAD BAND APPLICATIONS
- LOW C_{rss}
- SIMPLE BIAS CIRCUITS
- LOW NOISE
- HIGH GAIN – 13 dB MINIMUM

APPLICATIONS

- VHF/UHF COMMUNICATIONS
 from 1 MHz to 200 MHz

ABSOLUTE MAXIMUM RATINGS (T_{case} = 25°C unless otherwise stated)

P _D	Power Dissipation	438W
BV _{DSS}	Drain – Source Breakdown Voltage*	125V
BV _{GSS}	Gate – Source Breakdown Voltage*	±20V
I _{D(sat)}	Drain Current*	18A
T _{stg}	Storage Temperature	-65 to 150°C
T _j	Maximum Operating Junction Temperature	200°C

* Per Side

ELECTRICAL CHARACTERISTICS ($T_{case} = 25^{\circ}\text{C}$ unless otherwise stated)

Parameter		Test Conditions		Min.	Typ.	Max.	Unit
PER SIDE							
BV_{DSS}	Drain–Source Breakdown Voltage	$V_{GS} = 0$	$I_D = 100\text{mA}$	125			V
I_{DSS}	Zero Gate Voltage Drain Current	$V_{DS} = 50\text{V}$	$V_{GS} = 0$			6	mA
I_{GSS}	Gate Leakage Current	$V_{GS} = 20\text{V}$	$V_{DS} = 0$			1	μA
$V_{GS(th)}$	Gate Threshold Voltage*	$I_D = 10\text{mA}$	$V_{DS} = V_{GS}$	1		7	V
g_{fs}	Forward Transconductance*	$V_{DS} = 10\text{V}$	$I_D = 3\text{A}$	4.8			mhos
$V_{GS(th)match}$	Gate Threshold Voltage Matching Between Sides	$I_D = 10\text{mA}$	$V_{DS} = V_{GS}$			0.1	V
TOTAL DEVICE							
G_{PS}	Common Source Power Gain	$P_O = 300\text{W}$		13			dB
η	Drain Efficiency	$V_{DS} = 50\text{V}$	$I_{DQ} = 1.2\text{A}$	60			%
VSWR	Load Mismatch Tolerance	$f = 175\text{MHz}$		20:1			—
PER SIDE							
C_{iss}	Input Capacitance	$V_{DS} = 50\text{V}$	$V_{GS} = -5\text{V}$	$f = 1\text{MHz}$		360	pF
C_{oss}	Output Capacitance	$V_{DS} = 50\text{V}$	$V_{GS} = 0$	$f = 1\text{MHz}$		150	pF
C_{rss}	Reverse Transfer Capacitance	$V_{DS} = 50\text{V}$	$V_{GS} = 0$	$f = 1\text{MHz}$		9	pF

* Pulse Test: Pulse Duration = 300 μs , Duty Cycle $\leq 2\%$

HAZARDOUS MATERIAL WARNING

The ceramic portion of the device between leads and metal flange is beryllium oxide. Beryllium oxide dust is highly toxic and care must be taken during handling and mounting to avoid damage to this area.

THESE DEVICES MUST NEVER BE THROWN AWAY WITH GENERAL INDUSTRIAL OR DOMESTIC WASTE.

THERMAL DATA

$R_{THj-case}$	Thermal Resistance Junction – Case	Max. 0.4 $^{\circ}\text{C} / \text{W}$
----------------	------------------------------------	--

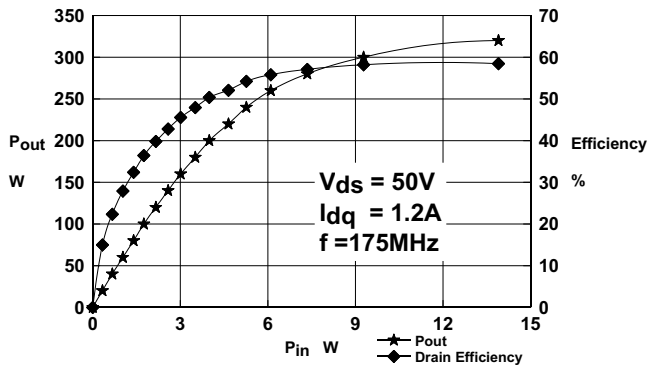

Figure 1 – Power Output and Efficiency vs. Power Input.

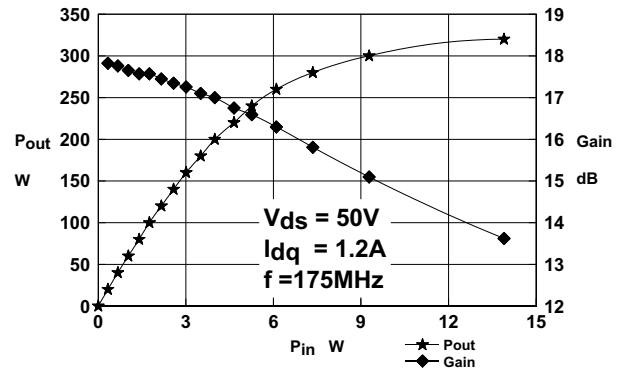

Figure 2 – Power Output & Gain vs. Power Input.

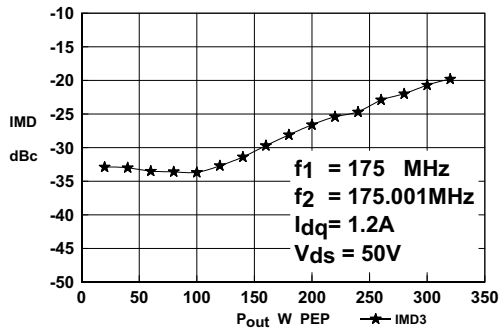

Figure 3 – IMD vs. Output Power.

D5028UK
OPTIMUM SOURCE AND LOAD IMPEDANCE
@ 300W / 50V

Frequency MHz	Z _S Ω	Z _L Ω
175	6.1 + j1	6.7 + j2.9

Typical S Parameters

! Vds=50V Idq=0.6A
 # MHZ S MA R 50

!Freq !Mhz	S11		S21		S12		S22	
	mag	ang	mag	ang	mag	ang	mag	ang
30	0.909	-146.2	14.21	101.4	0.015	14.9	0.497	-129.4
40	0.92	-153	10.87	92.2	0.015	7.4	0.515	-133.8
50	0.923	-157.9	8.804	85.8	0.015	2.6	0.545	-136
60	0.926	-160.9	7.352	79.3	0.015	-2.5	0.573	-138.4
70	0.936	-163.2	6.258	73.6	0.014	-6.5	0.613	-139.8
80	0.94	-165.1	5.381	67.8	0.013	-10.3	0.639	-141.6
90	0.941	-166.8	4.653	63.2	0.013	-13	0.669	-143.1
100	0.944	-167.9	4.022	58.8	0.011	-14.9	0.698	-144.2
110	0.946	-168.9	3.519	55.1	0.011	-15.2	0.726	-146.2
120	0.95	-169.1	3.099	51.4	0.01	-15.6	0.749	-147.5
130	0.955	-170.1	2.763	49.5	0.009	-14.2	0.773	-148.2
140	0.962	-171.1	2.501	47.3	0.009	-13.2	0.783	-149.7
150	0.961	-171.3	2.278	44.9	0.008	-11.9	0.806	-151.3
160	0.964	-173.2	2.092	41.5	0.007	-11.7	0.821	-152.3
170	0.963	-172.4	1.904	38	0.007	-10	0.839	-153.4
180	0.962	-173.1	1.706	34.6	0.006	-5.7	0.846	-154.7
190	0.97	-173.7	1.529	33.2	0.006	0.2	0.857	-156
200	0.974	-173.7	1.396	33	0.005	7.7	0.872	-156.2
210	0.974	-174.6	1.292	32.4	0.005	15.6	0.884	-157.3
220	0.974	-174.6	1.2	30.9	0.005	22.4	0.889	-158.5
230	0.974	-175.2	1.118	29	0.005	29	0.902	-159.4
240	0.98	-175.2	1.046	27.3	0.005	36.1	0.906	-159.9
250	0.977	-175.6	0.981	25.7	0.005	42.9	0.911	-159.9
260	0.978	-176	0.93	25.2	0.005	49.7	0.918	-161.2
270	0.983	-176.2	0.875	23.4	0.006	55.1	0.925	-161.3
280	0.984	-175.9	0.817	21.7	0.006	59.8	0.928	-162.5
290	0.984	-176.7	0.753	19.1	0.007	61.9	0.933	-162.6
300	0.983	-177	0.692	18.6	0.007	64.6	0.938	-163.5
310	0.986	-177	0.648	18.5	0.008	67.8	0.941	-163.6
320	0.985	-177.4	0.622	19.7	0.008	71.5	0.947	-164.5
330	0.985	-177.5	0.61	19.4	0.009	73.8	0.948	-164.3
340	0.987	-177.9	0.593	17.1	0.01	73.5	0.949	-164.9
350	0.988	-178.2	0.558	14.2	0.01	72.2	0.954	-165.6
360	0.986	-178.2	0.51	11.7	0.01	72	0.954	-165.6
370	0.988	-178.7	0.468	11.3	0.01	73.1	0.956	-166.2
380	0.987	-178.6	0.438	12.1	0.01	76.3	0.957	-166.6
390	0.99	-178.8	0.412	13.1	0.011	78.9	0.96	-166.9
400	0.99	-179.3	0.399	17.8	0.012	83.7	0.963	-167
410	0.988	-178.9	0.42	16.5	0.013	84.4	0.963	-167
420	0.988	-179.8	0.409	12.3	0.014	81.5	0.964	-168
430	0.988	-179.9	0.385	8.8	0.014	78.9	0.966	-167.8
440	0.986	-179.5	0.355	7.9	0.014	79.8	0.971	-168
450	0.992	179.9	0.333	8.6	0.015	81	0.973	-167.8
460	0.99	-179.8	0.317	9.6	0.015	82.6	0.969	-168.7
470	0.991	179.9	0.307	10.5	0.016	83.7	0.972	-168.6
480	0.99	179.2	0.299	10.8	0.017	83.8	0.972	-169.3
490	0.99	179.1	0.293	10.4	0.018	83.2	0.977	-168.7
500	0.988	178.9	0.286	9.2	0.018	82.1	0.973	-169.2

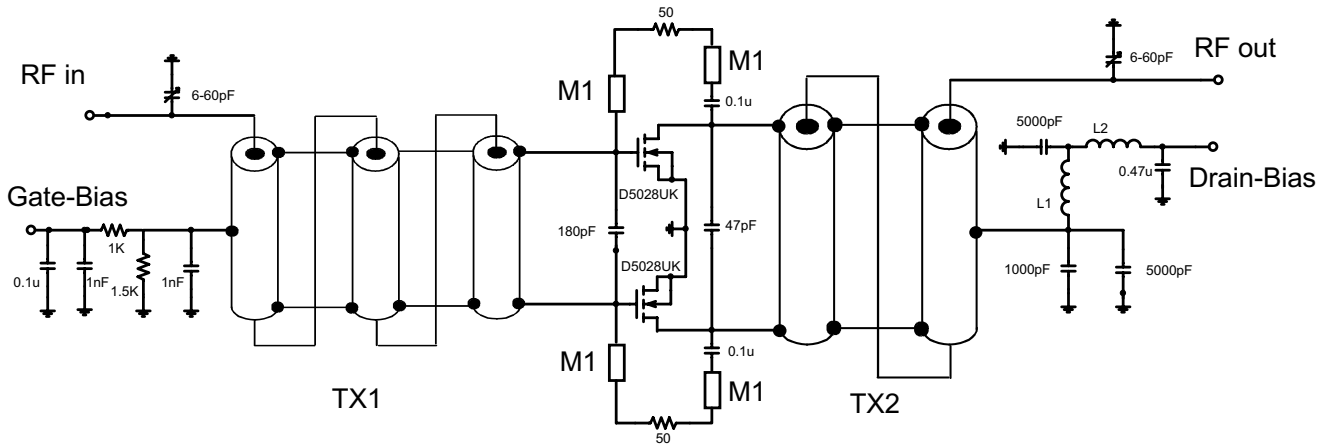

TX1 9:1 transformer. 3 turns of 062-25 semi-rigid coax around 75-26 powdered iron core

TX2 4:1 transformer. 2 turns of 090-25 semi-rigid coax around 100-8 powdered iron core

L1 10 turns 16 awg enamelled wire, 5mm internal diameter

L2 0.5 turns 16 awg enamelled wire on A1 x 1 2-hole core

M1 microstrip line, 20mm long, 1mm wide on 0.062in thick G10 substrate

D5028UK 175MHz TEST FIXTURE