

9097250 TOSHIBA (DISCRETE/OPTO)

56C 07781 D7-33-13

2SD777SILICON NPN DOUBLE DIFFUSED TYPE
(PCT PROCESS)POWER REGULATOR FOR LINE OPERATED
TV APPLICATIONS.

FEATURES:

- Excellent Wide Safe Operating Area
(100 W·S at $T_c=25^\circ\text{C}$).
- Included Abalanche Diode. : $V_Z=55\pm 10\text{V}$
- High D.C Current Gain. : $h_{FE}\geq 500$
- High Collector Power Dissipation Capability :
100 W at 25°C Case Temperature.

MAXIMUM RATINGS ($T_a=25^\circ\text{C}$)

CHARACTERISTIC	SYMBOL	RATING	UNIT
Collector-Base Voltage	V_{CB0}	55 ± 10	V
Collector-Emitter Voltage	V_{CE0}	55 ± 10	V
Emitter-Base Voltage	V_{EB0}	6	V
Collector Current (Continuous)	I_C	4	A
Collector Current (Peak)	I_{CP}	20	A
Collector Power Dissipation ($T_c=25^\circ\text{C}$)	P_C	100	W
Junction Temperature	T_j	150	$^\circ\text{C}$
Storage Temperature Range	T_{stg}	-65~150	$^\circ\text{C}$

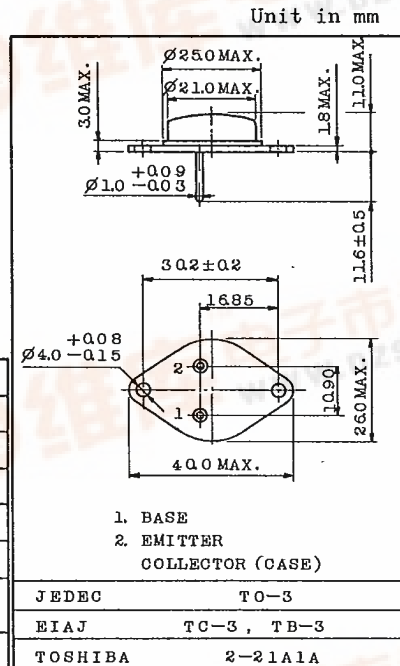
Mounting kit No. AC73
Weight: 12.0g

EQUIVALENT CIRCUIT

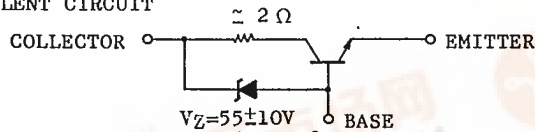
ELECTRICAL CHARACTERISTICS ($T_a=25^\circ\text{C}$)

CHARACTERISTIC	SYMBOL	TEST CONDITION	MIN.	TYP.	MAX.	UNIT
Collector-Base Breakdown Voltage	$V_{(BR)CBO}$	$I_C=10\text{mA}$, $I_E=0$	45	55	65	V
Collector-Emitter Breakdown Voltage	$V_{(BR)CE0}$	$I_C=100\text{mA}$, $I_B=0$	45	55	65	V
Emitter Cut-off Current	I_{EBO}	$V_{EB}=6\text{V}$, $I_C=0$	-	-	10	μA
DC Current Gain	h_{FE}	$V_{CE}=5\text{V}$, $I_C=500\text{mA}$	500	1000	2500	
Collector-Emitter Saturation Voltage	$V_{CE(sat)(1)}$	$I_C=500\text{mA}$, $I_B=2\text{mA}$	-	-	2.0	V
Collector-Emitter Saturation Voltage	$V_{CE(sat)(2)}$	$I_C=1.0\text{A}$, $I_B=20\text{mA}$	1.0	2.0	3.0	V
Base-Emitter Voltage	V_{BE}	$V_{CE}=5\text{V}$, $I_C=500\text{mA}$	0.50	0.65	0.80	V
Allowable Energy ($T_c=25^\circ\text{C}$)	E_T	Application Circuit	100	-	-	W·sec

TOSHIBA CORPORATION

2SD777

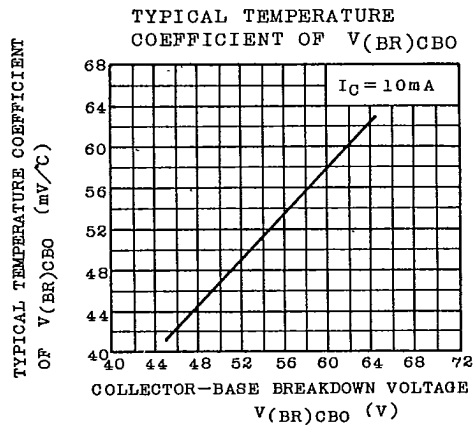
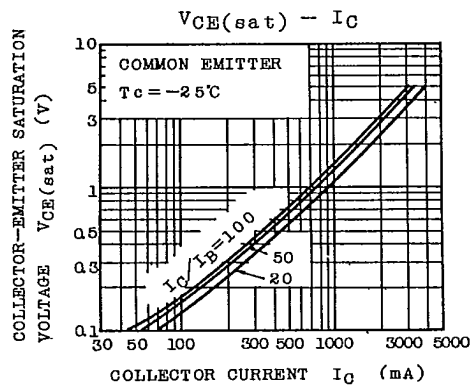
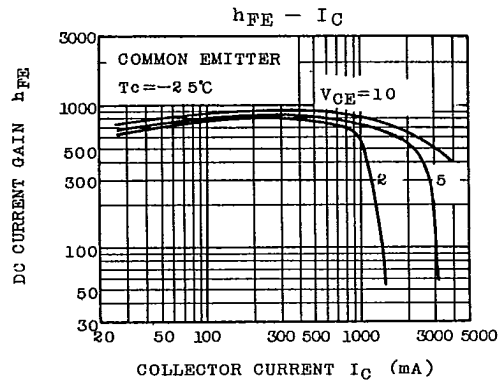
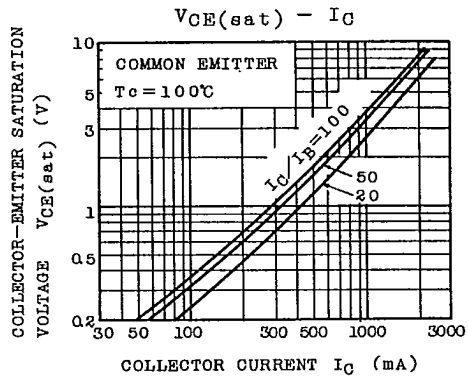
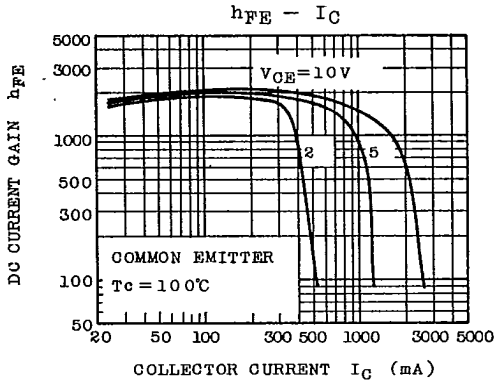
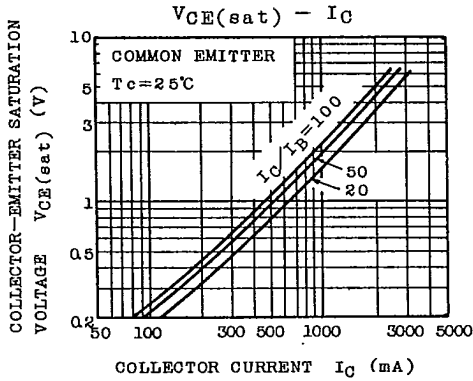

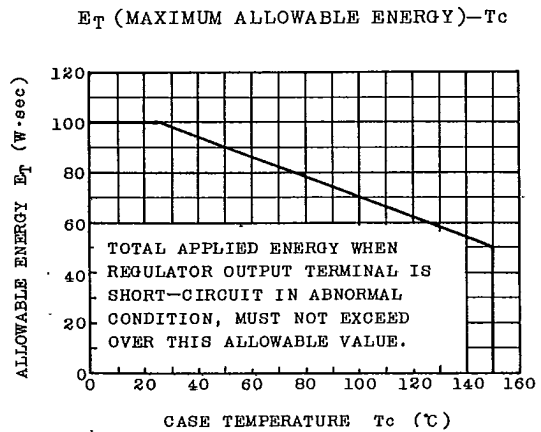
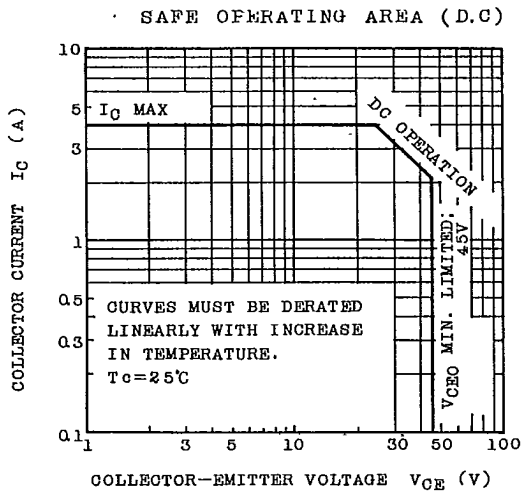
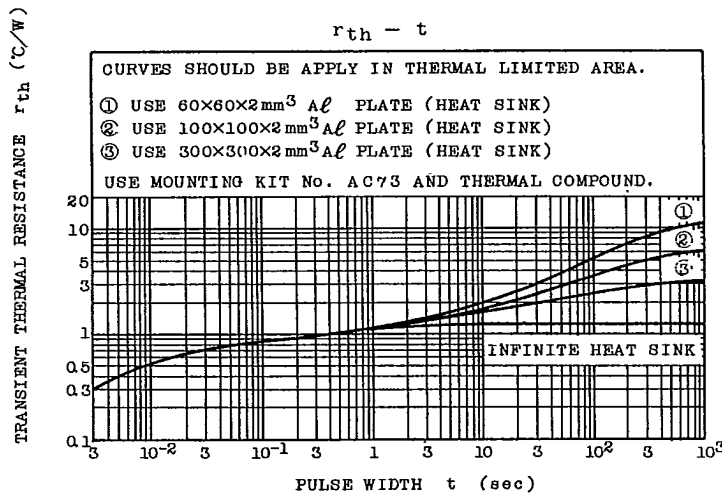

9097250 TOSHIBA (DISCRETE/OPTO) 56C 07785 DT-33-13
2SD777

APPLICATION CIRCUIT

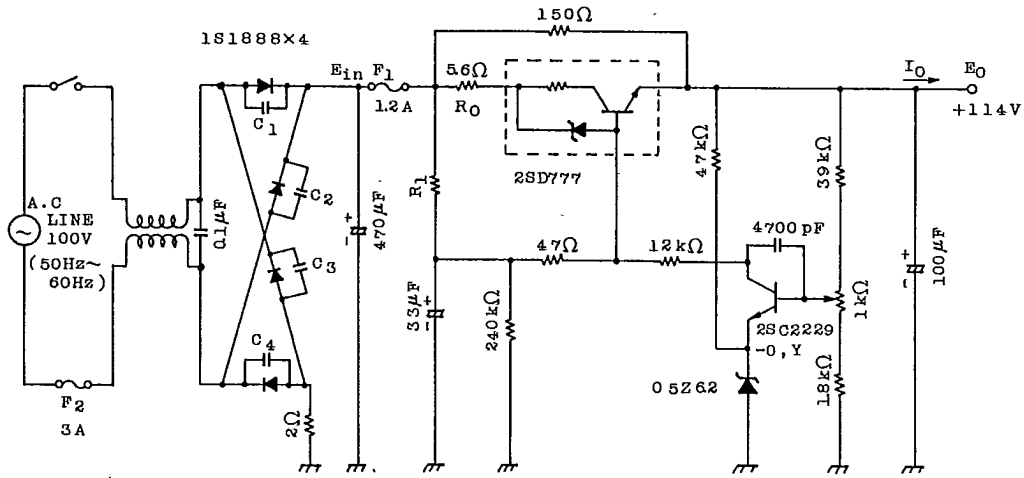

C₁, C₂, C₃, C₄ : 0.0047µF

FUSE F₁; I - t CHARACTERISTIC

