



## TDA2500

# STEREO CLASS-T DIGITAL AUDIO AMPLIFIER DRIVER USING DIGITAL POWER PROCESSING (DPP™) TECHNOLOGY

Preliminary Information

Revision 0.9 - May 2005

### GENERAL DESCRIPTION

The TDA2500 is a two-channel Amplifier Driver IC that uses Tripath's proprietary Digital Power Processing (DPP™) technology. Class-T amplifiers offer both the audio fidelity of Class-AB and the power efficiency of Class-D amplifiers.

The typical application for the TDA2500 is driving low impedance loads for professional and high-end consumer amplifiers. The feedback and voltage range of the TDA2500 can be configured externally unlike previous Tripath modules such as TA0104A. Thus, the TDA2500 is capable of emulating Tripath's previous series of TA0102A, TA0103A, and TA0104A amplifier drivers with the addition of a small number of external components.

### APPLICATIONS

- Pro-audio Amplifiers
- Distribution Amplifiers
- High-end Audio Amplifiers

### BENEFITS

- Reduced system cost with smaller/less expensive power supply and heat sink
- Signal fidelity equal to high quality Class-AB amplifiers
- No output transformer is needed due to high supply voltage range
- High dynamic range compatible with digital media such as CD and DVD

### FEATURES

- Class-T architecture
- Proprietary Digital Power Processing technology
- High Supply Voltage Range
- "Audiophile" Sound Quality
- High Efficiency
- Supports wide range of output power levels
- Output over-current protection
- Over and under-voltage protection
- 38-pin Quad package



**Absolute Maximum Ratings** (Note 1)

SYMBOL	PARAMETER	Value	UNITS
VPP, VNN	Supply Voltage (Note 2)	+/-200	V
V5	Positive 5V Controller Voltage Voltage at Input Pins (pins 4-8, 10-11)	6 -0.3 to (V5+0.3)	V V
VN12	Voltage for FET drive	VNN+18	V
T <sub>A</sub>	Operating Free-air Temperature Range	0° to 70°	C
T <sub>J</sub>	Junction Temperature	150°	C
T <sub>STORE</sub>	Storage Temperature Range	-40° to 150°	C
ESD <sub>HB</sub>	ESD Susceptibility – Human Body Model (Note 3) All Pins	2000	V
ESD <sub>MM</sub>	ESD Susceptibility – Machine Model (Note 4) All Pins	200	V

Note 1: Absolute Maximum Ratings indicate limits beyond which damage to the device may occur.

See the table below for Operating Conditions.

Note 2: Limits based on components used inside the hybrid module. The internal over current circuit is not capable of working above +/-130V due to bias level. An external over current circuit must be implemented for operation above +/-130V. In most cases, the TA0105A is the best choice for operation above +/-130V. A data sheet for the TA0105A can be found on the Tripath website at [www.tripath.com](http://www.tripath.com).

Note 3: Human body model, 100pF discharged through a 1.5KΩ resistor.

Note 4: Machine model, 220pF – 240pF discharged through all pins.

**Operating Conditions** (Note 5)

SYMBOL	PARAMETER	MIN.	TYP.	MAX.	UNITS
VPP, VNN	Supply Voltage (Note 5)	+/-125	+/-148	+/-185	V
V5	Positive 5V Controller Voltage	4.5	5	5.5	V
VN12	Voltage for FET drive (Volts about VNN)	10.8	12	13.2	V

**Note 5:** The VPP and VNN supply limits are based on the internal OV/UV sensing resistor values. The supply voltage range can be lowered via external resistors. In the typical application of the TDA2500, the external resistors R<sub>VPP1</sub>, R<sub>VPP2</sub>, R<sub>VNN1</sub> and R<sub>VNN2</sub> will be implemented, allowing operation down to +/-20V, if needed, to emulate previous Tripath hybrid drivers. Please refer to the Application information section for a detailed discussion of changing the operating supply voltage range and emulating such devices as TA0104A, TA0103A and TA0102A.

**Electrical Characteristics** (Note 6)

$T_A = 25\text{ }^\circ\text{C}$ . See Application/Test Circuit on page 7. Unless otherwise noted, the supply voltage is  $V_{PP} = |V_{NN}| = 90\text{V}$ . See Note 9.

SYMBOL	PARAMETER	CONDITIONS	MIN.	TYP.	MAX.	UNITS
$I_q$	Quiescent Current (No load, $BBM0=0, BBM1=1$ , Mute = 0V)	$V_{PP} = +90\text{V}$		45		mA
		$V_{NN} = -90\text{V}$		45		mA
		$V_5 = 5\text{V}$		45		mA
		$V_{N12} = 12\text{V}$		190		mA
$I_{MUTE}$	Mute Supply Current (No load, Mute = 5V)	$V_{PP} = +90\text{V}$		1		mA
		$V_{NN} = -90\text{V}$		1		mA
		$V_5 = 5\text{V}$		20	30	mA
		$V_{N12} = 12\text{V}$		1		mA
$I_{Po}$	Power Supply Current ( $P_o = 500\text{W}$ , $R_L = 4\Omega$ )	$V_{PP} = +90\text{V}$ (Both Channels On)		7.05		A
		$V_{NN} = -90\text{V}$ (Both Channels On)		7.05		A
$V_{IH}$	High-level input voltage (MUTE)		3.5			V
$V_{IL}$	Low-level input voltage (MUTE)				1.0	V
$V_{OH}$	High-level output voltage (HMUTE)	$R_L = 10\text{kohm}$	3.5			V
$V_{OL}$	Low-level output voltage (HMUTE)	$R_L = 10\text{kohm}$			0.5	V
$V_{OFFSET}$	Output Offset Voltage	No Load, MUTE = Logic low, Measured without external trim circuit connected, 1% $R_{FB}$ matching	-1.25		1.25	V
$I_{OC}$	Over Current Sense Voltage Threshold	Exceeding this threshold causes a latched mute condition	0.85	0.97	1.09	V
$V_{VPPSENSE}$	VPP Threshold Voltages (Internal setting)	Over-voltage turn on (muted)	193	227	250	V
		Over-voltage restart (mute off)	185	216		V
		Under-voltage restart (mute off)		111	125	V
		Under-voltage turn on (muted)	80	101	118	V
$V_{VNNSENSE}$	VNN Threshold Voltages (Internal setting)	Over-voltage turn on (muted)	-193	-221	-250	V
		Over-voltage restart (mute off)	-185	-215		V
		Under-voltage restart (mute off)		-110	-125	V
		Under-voltage turn on (muted)	-80	-98	-118	V
$V_{VPPSENSE}$	VPP Threshold Voltages (Externally shifted) (Note 7)	Over-voltage turn on (muted)	98	111	123	V
		Over-voltage restart (mute off)	93	106		V
		Under-voltage restart (mute off)		54	60	V
		Under-voltage turn on (muted)	42	49	55	V
$V_{VNNSENSE}$	VNN Threshold Voltages (Externally shifted) (Note 7)	Over-voltage turn on (muted)	-96	-108	-120	V
		Over-voltage restart (mute off)	-93	-105		V
		Under-voltage restart (mute off)		-53	-60	V
		Under-voltage turn on (muted)	-40	-48	-55	V

Note 6: Minimum and maximum limits are guaranteed but may not be 100% tested.

Note 7: These voltage values are calculated and not 100% tested. The voltages are based on 100% tested sense currents, the internal over-voltage and under-voltage resistors, and external "shift" resistors as follows:  $R_{VPP1} = R_{VPP2} = 1.33\text{M}\Omega$ ,  $R_{VNN1} = 1.21\text{M}\Omega$  and  $R_{VNN2} = 3.57\text{M}\Omega$ . In addition, worse case resistor tolerances (+/-1%) were used to calculate the minimum and maximum values. Please refer to the Over-voltage and Under-voltage Protection section of the Applications Information on how to set the operating voltage supply range.

**Electrical Characteristics** (Notes 8 and 9)

$T_A = 25\text{ }^\circ\text{C}$ . Unless otherwise noted, the supply voltage is  $V_{PP}=|V_{NN}|=90\text{V}$ , the input frequency is 1kHz and the measurement bandwidth is 20kHz. See Application/Test Circuit.

SYMBOL	PARAMETER	CONDITIONS	MIN.	TYP.	MAX.	UNITS	
$P_{OUT}$	Output Power (Continuous Output/Channel)	$V_{PP}= V_{NN} =90\text{V}$ , $R_L = 4\Omega$		1100		W	
		THD+N=10%		800		W	
		THD+N=1%		650		W	
		THD+N=0.1%					
		$V_{PP}= V_{NN} =90\text{V}$ , $R_L = 8\Omega$			550		W
		THD+N=10%			425		W
		THD+N=1%			350		W
		THD+N=0.1%					
		$V_{PP}= V_{NN} =75\text{V}$ , $R_L = 4\Omega$			800		W
		THD+N=10%			600		W
		THD+N=1%			500		W
		THD+N=0.1%					
		$V_{PP}= V_{NN} =75\text{V}$ , $R_L = 8\Omega$		425		W	
		THD+N=10%		325		W	
		THD+N=1%		275		W	
		THD+N=0.1%					
THD + N	Total Harmonic Distortion Plus Noise	$f = 1\text{kHz}$ , $R_L = 8\Omega$ , $P_{OUT} = 50\text{W/Channel}$		0.015		%	
THD + N	Total Harmonic Distortion Plus Noise	$f = 1\text{kHz}$ , $R_L = 4\Omega$ , $P_{OUT} = 50\text{W/Channel}$		0.02		%	
IMD	Intermodulation Distortion	19kHz, 20kHz, 1:1, $R_L = 8\Omega$ $P_{OUT} = \text{TBDW/Channel}$		0.02		%	
SNR	Signal-to-Noise Ratio	A-Weighted, $R_L = 4\Omega$ , $P_{OUT} = 500\text{W/Channel}$		103		dB	
CS	Channel Separation	0dB <sub>r</sub> = 10W, $R_L = 4\Omega$ , $f = 1\text{kHz}$		87		dB	
$\eta$	Power Efficiency	$P_{OUT} = 300\text{W/Channel}$ , $R_L = 8\Omega$		88		%	
$\eta$	Power Efficiency	$P_{OUT} = 500\text{W/Channel}$ , $R_L = 4\Omega$		79		%	
$A_V$	Amplifier Gain	$P_{OUT} = 10\text{W/Channel}$ , $R_L = 8\Omega$ , $R_{in} = 49.9\text{k}\Omega$ , See Application / Test Circuit		14.6		V/V	
$A_{ERROR}$	Channel to Channel Gain Error	$P_{OUT} = 10\text{W/Channel}$ , $R_L = 8\Omega$	-1		1	dB	
$e_{NOUT}$	Output Noise Voltage	A-Weighted, input shorted, DC offset nulled to zero		325		$\mu\text{V}$	

Note 8: Minimum and maximum limits are guaranteed but may not be 100% tested.

Note 9: Specific Components used:

Output MOSFETs ( $Q_O$ ): ST Microelectronics STW34NB20

Feedback Resistors ( $R_{FB}$ ): 18.7K $\Omega$ , 1%, 1W

Output Diodes ( $D_O$ ): International Rectifier MUR420

# TDA2500 Pinout

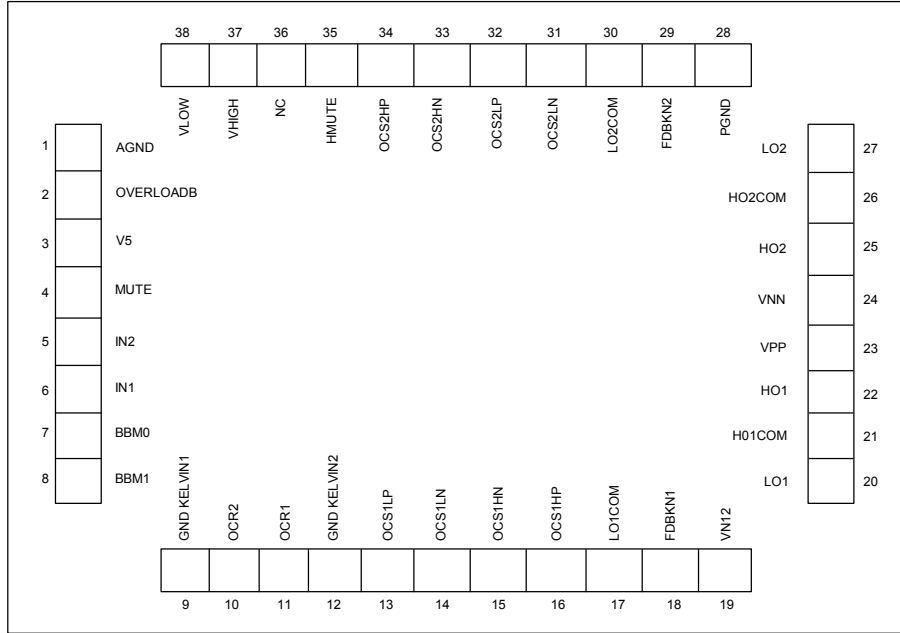

## Pin Description

Pin	Function	Description
1	AGND	Analog ground. This should be the “star” point for all connections to analog ground.
2	OVERLOADB	Normally logic high. Logic low signals onset of clipping. Pin output impedance is approximately 100k $\Omega$ .
3	V5	5V power supply input.
4	MUTE	Logic input. A logic high puts the amplifier in mute mode. Ground pin if not used. Please refer to the section, Mute Control, in the Application Information.
5, 6	IN2, IN1	Audio inputs. (Channels 2 & 1)
7, 8	BBM0, BBM1	Break-before-make timing control to prevent shoot-through in the output MOSFETs.
9, 12	GNDKELVIN1, GNDKELVIN2	Output ground feedback (Channels 1 & 2)
10, 11	OCR2, OCR1	Over-current threshold adjustment (Channels 2 & 1). These pins directly access the internal over current, voltage comparators. The threshold for over current detection is $V_{TOC}$ , as specified in the Electrical Characteristics section.
13, 14	OCS1LP, OCS1LN	Over Current Sense inputs, Channel 1 low-side
15, 16	OCS1HN, OCS1HP	Over Current Sense inputs, Channel 1 high-side
17,30	LO1COM, LO2COM	Kelvin connection to source of low-side transistor (Channel 1 & 2)
18, 29	FDBKN1, FDBKN2	Switching feedback (Channels 1 & 2)
19	VN12	“Floating” supply input for the FET drive circuitry. This voltage must be stable and referenced to VNN.
20,27	LO1, LO2	Low side gate drive output (Channel 1 & 2)
21,26	HO1COM, HO2COM	Kelvin connection to source of high-side transistor (Channel 1 & 2)
22,25	HO1, HO2	High side gate drive output (Channel 1 & 2)
23	VPP	Positive supply voltage input. Connect to positive power supply. Used for power supply sensing.
24	VNN	Negative supply voltage input. Connect to positive power supply. Used for power supply sensing.
28	PGND	Power ground. This should be connected to the “star” point for the power (output) ground.
31, 32	OCS2LN, OCS2LP	Over Current Sense inputs, Channel 2 low-side
33, 34	OCS2HN, OCS2HP	Over Current Sense inputs, Channel 2 high-side
35	HMUTE	Logic Output. A logic high indicates both amplifiers are muted, due to the mute pin state, or a “fault” such as an overcurrent, undervoltage, or overvoltage condition.
36	NC	Do not connect.
37	VHIGH	Positive supply voltage sense input. This pin is biased at 2.5V nominally and left floating in typical applications. Typically, external resistors will be connected to VHIGH to lower the supply voltage operation range. See the Application Information for a detailed description on how to lower the supply voltage range.
38	VLOW	Negative supply voltage sense input. This pin is biased at 1.25V nominally and left floating in typical applications. Typically, external resistors will be connected to VLOW to lower the supply voltage operation range. See the Application Information for a detailed description on how to lower the supply voltage range.

Application/Test Circuit

TDA2500

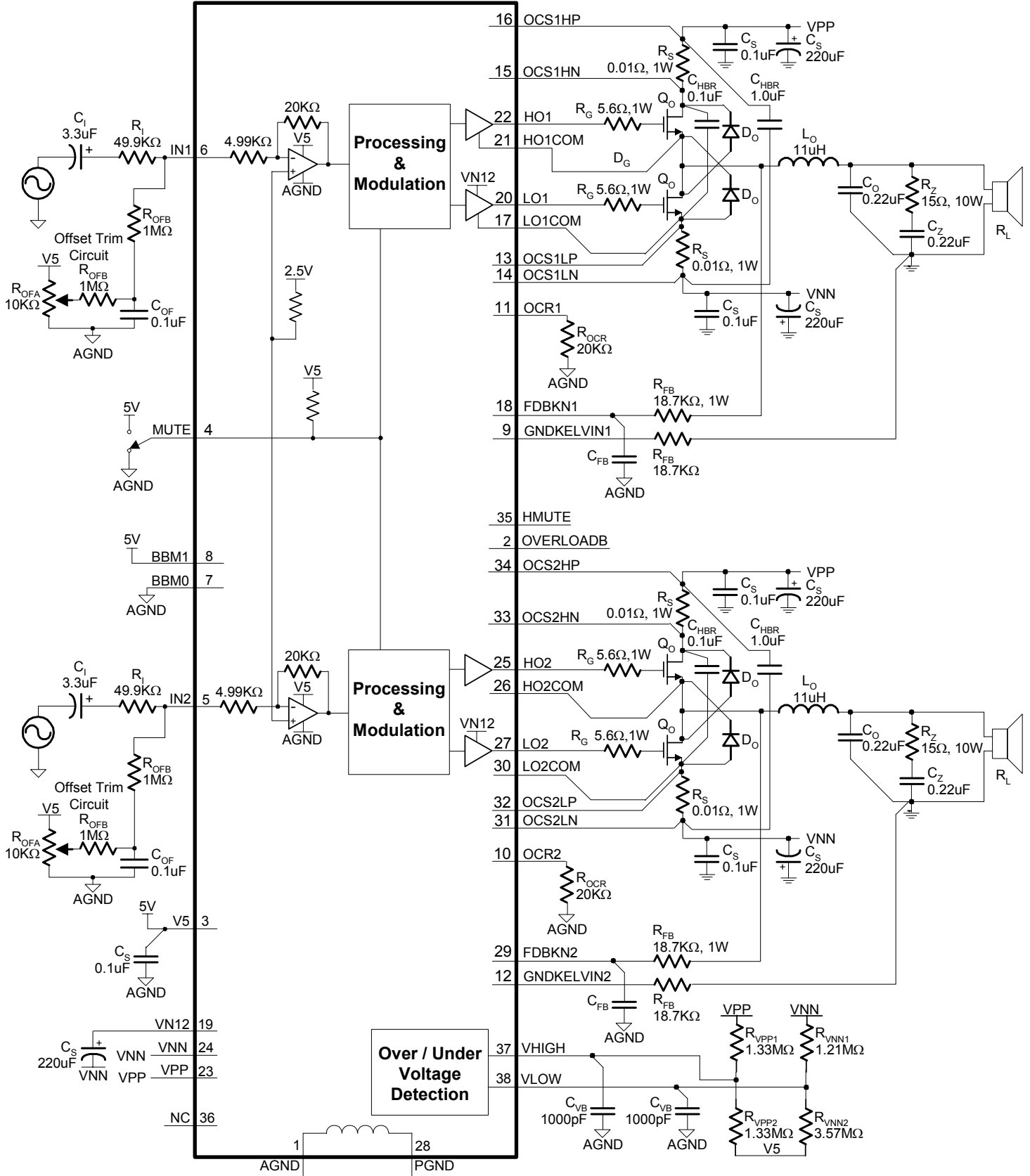

**External Components Description** (Refer to the Application/Test Circuit)

Components	Description
R <sub>I</sub>	Inverting input resistance to provide AC gain in conjunction with R <sub>F</sub> . This input is biased at the BIASCAP voltage (approximately 2.5VDC).
C <sub>I</sub>	AC input coupling capacitor which, in conjunction with R <sub>I</sub> , forms a highpass filter at $f_c = 1/(2\pi R_I C_I)$ .
R <sub>FB</sub>	Feedback resistor connected from either the half-bridge output to FDBKN1 (FDBKN2) or speaker ground to GNDKELVIN1 (GNDKELVIN2). The value of this depends on the supply voltage range and sets the TDA2500 gain in conjunction with R <sub>I</sub> . It should be noted that the feedback resistor from the half-bridge output must have a power rating of greater than $P_{DISS} = VPP^2/2R_{FB}$ . Please see the Modulator Feedback Design paragraphs in the Application Information Section.
C <sub>FB</sub>	Feedback delay capacitor that both lowers the idle switching frequency and filters very high frequency noise from the feedback signal, which improves amplifier performance. The value of C <sub>FB</sub> should be offset between channel 1 and channel 2 so that the idle switching difference is greater than 40kHz. Please refer to the Application / Test Circuit.
R <sub>OFA</sub>	Potentiometer used to manually trim the DC offset on the output of the TDA2500.
R <sub>OFFB</sub>	Resistor that limits the manual DC offset trim range and allows for more precise adjustment.
C <sub>OF</sub>	Decoupling capacitor which low pass filters the offset trim voltage from noise and power supply fluctuations.
C <sub>S</sub>	Supply decoupling for the power supply pins. For optimum performance, these components should be located close to the TDA2500 and returned to their respective ground as shown in the Application/Test Circuit.
R <sub>S</sub>	Over-current sense resistor. Please refer to the section, Setting the Over-current Threshold, in the Application Information for a discussion of how to choose the value of R <sub>S</sub> to obtain a specific current limit trip point.
R <sub>OCCR</sub>	Over-current "trim" resistor, which, in conjunction with R <sub>S</sub> , sets the current trip point. Please refer to the section, Setting the Over-current Threshold, in the Application Information for a discussion of how to calculate the value of R <sub>OCCR</sub> .
C <sub>HBR</sub>	Supply decoupling for the high current Half-bridge supply pins. These components must be located as close to the output MOSFETs as possible to minimize output ringing which causes power supply overshoot. By reducing overshoot, these capacitors maximize both the TDA2500 and output MOSFET reliability. These capacitors should have good high frequency performance including low ESR and low ESL. In addition, the capacitor rating must be twice the maximum VPP voltage.
Q <sub>O</sub>	Output MOSFET. This is the main output switching device and to a large extent, sets the amplifier's limitations. This device must be a switching grade device with a good compromise between gate charge and on resistance while being able to withstand the full supply range. Please refer to the recommended devices in the Applications Information section.
D <sub>O</sub>	Output diode, which is used to minimize output overshoots/undershoots on the output node. These devices clamp the output to low impedance node formed by the close connection of CHBR. Note the connection shown in the Application/Test Circuit. The "drain to drain" diode protects the bottom side device from excessive BVDSS due to overshoots on the output node. The "source to source" diode protects the top side device from excessive BVDSS due to undershoots on the output node. This device must be an ultra fast rectifier capable of sustaining the entire supply range (VPP-VNN) and high peak currents.
R <sub>G</sub>	Gate resistor, which is used to control the MOSFET rise/ fall times. This resistor serves to dampen the parasitics at the MOSFET gates, which, in turn, minimizes ringing and output overshoots. The typical power rating is 1 watt.
C <sub>Z</sub>	Zobel capacitor, which in conjunction with R <sub>Z</sub> , terminates the output filter at high frequencies. Use a high quality film capacitor capable of sustaining the ripple current caused by the switching outputs.



R <sub>Z</sub>	Zobel resistor, which in conjunction with C <sub>Z</sub> , terminates the output filter at high frequencies. The combination of R <sub>Z</sub> and C <sub>Z</sub> minimizes peaking of the output filter under both no load conditions or with real world loads, including loudspeakers which usually exhibit a rising impedance with increasing frequency. Depending on the program material, the power rating of R <sub>Z</sub> may need to be adjusted. Typically 10 watts. If the system requires full power operation at 20kHz then the power rating for R <sub>Z</sub> will likely need to be increased.
L <sub>O</sub>	Output inductor, which in conjunction with C <sub>O</sub> , demodulates (filters) the switching waveform into an audio signal. Forms a second order filter with a cutoff frequency of $f_c = 1/(2\pi\sqrt{L_O C_O})$ and a quality factor of $Q = R_L C_O / \sqrt{L_O C_O}$ .
C <sub>O</sub>	Output capacitor, which, in conjunction with L <sub>O</sub> , demodulates (filters) the switching waveform into an audio signal. Forms a second order low-pass filter with a cutoff frequency of $f_c = 1/(2\pi\sqrt{L_O C_O})$ and a quality factor of $Q = R_L C_O / \sqrt{L_O C_O}$ . Use a high quality film capacitor capable of sustaining the ripple current caused by the switching outputs.
C <sub>VB</sub>	Supply decoupling for the power supply sensing pins. For optimum performance, these components should be located close to the TDA2500 and returned to analog ground.
R <sub>VNN1</sub>	Main over-voltage and under-voltage sense resistor for the negative supply (VNN). Please refer to the Electrical Characteristics Section for the trip points as well as the hysteresis band. Also, please refer to the Over / Under-voltage Protection section in the Application Information for a detailed discussion of the internal circuit operation and external component selection.
R <sub>VNN2</sub>	Secondary over-voltage and under-voltage sense resistor for the negative supply (VNN). This resistor accounts for the internal V <sub>NNSENSE</sub> bias of 1.25V. Nominal resistor value should be three times that of R <sub>VNN1</sub> . Please refer to the Over / Under-voltage Protection section in the Application Information for a detailed discussion of the internal circuit operation and external component selection.
R <sub>VPP1</sub>	Main over-voltage and under-voltage sense resistor for the positive supply (VPP). Please refer to the Electrical Characteristics Section for the trip points as well as the hysteresis band. Also, please refer to the Over / Under-voltage Protection section in the Application Information for a detailed discussion of the internal circuit operation and external component selection.
R <sub>VPP2</sub>	Secondary over-voltage and under-voltage sense resistor for the positive supply (VPP). This resistor accounts for the internal V <sub>PPSENSE</sub> bias of 2.5V. Nominal resistor value should be equal to that of R <sub>VPP1</sub> . Please refer to the Over / Under-voltage Protection section in the Application Information for a detailed discussion of the internal circuit operation and external component selection.

**Typical Performance**

<p><b>THD+N vs Output Power</b></p> <p><b>+/-90V</b>  <b>4OHM</b>  <b>f = 1kHz, 7kHz</b>  <b>AES 17 FILTER</b></p>	<p><b>THD+N vs Output Power</b></p> <p><b>+/-90V</b>  <b>8OHM</b>  <b>f = 1kHz, 7kHz</b>  <b>AES 17 FILTER</b></p>
<p><b>THD+N vs Output Power</b></p> <p><b>+/-65V +/-75V, +/-90V</b>  <b>4 OHM</b>  <b>f = 1kHz</b>  <b>AES 17 FILTER</b></p>	<p><b>THD+N vs Output Power</b></p> <p><b>+/-65V +/-75V, +/-90V</b>  <b>8OHM</b>  <b>f = 1kHz</b>  <b>AES 17 FILTER</b></p>
<p><b>THD+N vs Frequency</b></p> <p><b>+/- 90V</b>  <b>4 OHM</b>  <b>PO =TBDW</b>  <b>f = 1kHz</b>  <b>BW = 22kHz, 30kHz</b></p>	<p><b>THD+N vs Frequency</b></p> <p><b>+/- 90V</b>  <b>8 OHM</b>  <b>PO =TBDW</b>  <b>f = 1kHz</b>  <b>BW = 22kHz, 30kHz</b></p>

<b>IMD</b>  <b>+/-90V</b> <b>4OHM</b> <b>Po=TBDW</b>	<b>IMD</b>  <b>+/-90V</b> <b>8OHM</b> <b>Po=TBDW</b>
<b>Noise Floor</b>  <b>4 ohm</b> <b>AES 17 FILTER</b> <b>+/-90V</b> <b>32k FFT 65KHZ</b>	<b>Channel Separation</b>  <b>4 ohm</b> <b>+/-90V</b> <b>Po = 10W</b> <b>AES 17 FILTER</b>
<b>Efficiency and Power Dissipation</b>  <b>+/-90V</b> <b>4 OHM</b> <b>f =1kHz</b> <b>THD&lt;=10%</b> <b>AES 17 FILTER</b>	<b>Efficiency and Power Dissipation</b>  <b>+/-90V</b> <b>8 OHM</b> <b>f =1kHz</b> <b>THD&lt;=10%</b> <b>AES 17 FILTER</b>

## Application Information

Figure 1 is a simplified diagram of one channel (Channel 1) of a TDA2500 amplifier to assist in understanding its operation.

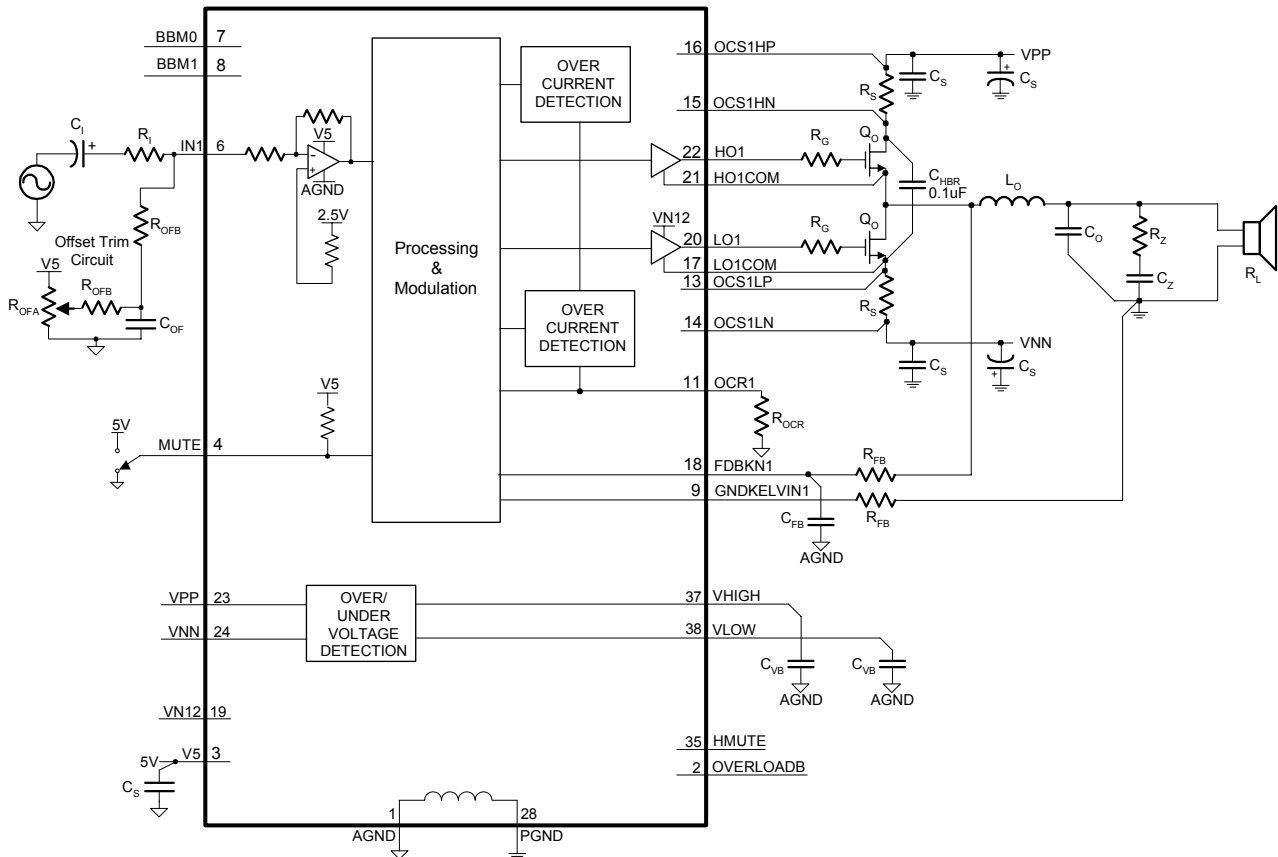

Figure 1: Simplified TDA2500 Amplifier

## TDA2500 BASIC AMPLIFIER OPERATION

The audio input signal is fed to the processor internal to the TDA2500, where a switching pattern is generated. The average idle (no input) switching frequency is approximately 700kHz and can be adjusted by changing the  $C_{FB}$  value. The idle switching frequency must be maintained above 575kHz to ensure proper device operation. With an input signal, the pattern is spread spectrum and varies between approximately 200kHz and 1.5MHz depending on input signal level and frequency. Complementary copies of the switching pattern are level-shifted by the MOSFET drivers and output from the TDA2500 where they drive the gates (HO1 and LO1) of external power MOSFETs that are connected as a half bridge. The output of the half bridge is a power-amplified version of the switching pattern that switches between VPP and VNN. This signal is then low-pass filtered to obtain an amplified reproduction of the audio input signal.

The processor portion of the TDA2500 is operated from a 5-volt supply. In the generation of the switching patterns for the output MOSFETs, the processor inserts a "break-before-make" dead time between the turn-off of one transistor and the turn-on of the other in order to minimize shoot-through currents in the MOSFETs. The dead time can be programmed by setting the break-before-make control bits, BBM1 and BBM0. Feedback information from the output of the half-bridge is supplied to the processor via FBKOUT1. Additional feedback information to account for ground bounce is supplied via FBKGND1.

The MOSFET drivers in the TDA2500 are operated from voltages obtained from VN12 and LO1COM for the low-side driver, and bootstrap voltage (internally generated) and HO1COM for the high-side driver. VN12 must be a regulated 12V above VNN.

N-Channel MOSFETs are used for both the top and bottom of the half bridge. The gate resistors,  $R_G$ , are used to control MOSFET slew rate and thereby minimize voltage overshoots. If used, gate diodes,  $D_G$ , reduce the MOSFET turn-off time, thus reducing cross conduction and idle supply current.

## **CIRCUIT BOARD LAYOUT**

The TDA2500 is a power (high current) amplifier that operates at relatively high switching frequencies. The output of the amplifier switches between VPP and VNN at high speeds while driving large currents. This high-frequency digital signal is passed through an LC low-pass filter to recover the amplified audio signal. Since the amplifier must drive the inductive LC output filter and speaker loads, the amplifier outputs can be pulled above the supply voltage and below ground by the energy in the output inductance. To avoid subjecting the TDA2500 and external mosfets to potentially damaging voltage stress, it is critical to have a good printed circuit board layout. It is recommended that Tripath's layout and application circuit be used for all applications and only be deviated from after careful analysis of the effects of any changes. Please refer to the TDA2500 evaluation board document, RB-TDA2500, available on the Tripath website, at [www.tripath.com](http://www.tripath.com).

The following components are important to place near either their associated TDA2500 or output MOSFET pins. The recommendations are ranked in order of layout importance, either for proper device operation or performance considerations.

- The impedance of the output node (the connection between the top side MOSFET source to bottom side MOSFET drain) must be minimized. Reducing the parasitic trace inductance is the most effective way of limiting output node ringing. A flat, bar conductor, in parallel with the PCB output node trace, is quite effective at minimizing the inductance thereby reducing output transients due to the switching architecture.
- The capacitors,  $C_{HBR}$ , provide high frequency bypassing of the amplifier power supplies and will serve to reduce spikes and modulation of the power supply rails. Please note that both mosfet half-bridges must be decoupled separately. In addition, the voltage rating for  $C_{HBR}$  should be at least 400V as this capacitor is exposed to the full supply range, VPP-VNN.
- The output diodes,  $D_O$ , are used to minimize overshoots/undershoots on the output node. Please note that the proper connection of these is "Drain to Drain" and "Source to Source" as shown in the Application/Test Circuit. Improper routing of these diodes will render them useless due to PCB trace inductance.
- The gate resistors,  $R_G$ , should be located as close to the output MOSFET gates leads as possible. In addition, the trace length from the pins LOx/HOx to the gate resistor should be minimized. To reduce the loop area, a parallel trace from LOxCOM/HOxCOM should be routed directly to the respective MOSFET source lead.
- $C_{FB}$  removes very high frequency components from the amplifier feedback signals and lowers the output switching frequency by delaying the feedback signals. In addition, the value of  $C_{FB}$  is different for channel 1 and channel 2 to keep the average switching frequency difference greater than 40kHz. This minimizes in-band audio noise. Locate these capacitors as close to their respective TDA2500 pin as possible.

Some components are not sensitive to location but are very sensitive to layout and trace routing.

- The routing of the sense resistors,  $R_S$ , must be Kelvin connected. This implies a direct trace from the respective TDA2500 pin to the sense resistor lead without interruption. If additional

connections are made to the TDA2500 over current sense pins or the traces, the overcurrent sense circuit may prematurely trigger.

- To maximize the damping factor and reduce distortion and noise, the modulator feedback connections should be routed directly to the pins of the output inductors,  $L_O$ . Please refer to the RB-TDA2500 layout for additional information.
- The output filter capacitor,  $C_O$ , and zobel capacitor,  $C_Z$ , should be star connected with the load return. The output ground feedback signal should be taken from this star point.
- To minimize the possibility of any noise pickup, the trace lengths of IN1 and IN2 should be kept as short as possible. This is most easily accomplished by locating the input resistors,  $R_I$  as close to the TDA2500 as possible. In addition, the offset trim resistor,  $R_{OFB}$ , which connects to either IN1, or IN2, should be located close to the TDA2500 input section.

## **TDA2500 GROUNDING**

Proper grounding techniques are required to maximize TDA2500 functionality and performance. Parametric parameters such as THD+N, Noise Floor and Crosstalk can be adversely affected if proper grounding techniques are not implemented on the PCB layout. The following discussion highlights some recommendations about grounding both with respect to the TDA2500 as well as general “audio system” design rules.

The TDA2500 is divided into two sections: the input section, which spans pins 1-12 and pins 35-38 and the output (high voltage) section, which spans pins 13 through pin 34. On the TDA2500 evaluation board, the ground is also divided into distinct sections, one for the input and one for the output. To minimize ground loops and keep the audio noise floor as low as possible, the input and output ground should not be externally connected. They are already connected internally via a ferrite bead between pin 1 and pin 28. Additionally, any external input circuitry such as preamps, or active filters, should be referenced to pin 1.

For the power section, Tripath has traditionally used a “star” grounding scheme. Thus, the load ground returns and the power supply decoupling traces are routed separately back to the power supply. In addition, any type of shield or chassis connection would be connected directly to the ground star located at the power supply. These precautions will both minimize audible noise and enhance the crosstalk performance of the TDA2500.

The TDA2500 incorporates a differential feedback system to minimize the effects of ground bounce and cancel out common mode ground noise. As such, the feedback from the output ground for each channel needs to be properly sensed. This can be accomplished by connecting the output ground “sensing” trace directly to the star formed by the output ground return, output capacitor,  $C_O$ , and the zobel capacitor,  $C_Z$ . Refer to the Application / Test Circuit for a schematic description.

## **TDA2500 THERMAL MANAGEMENT**

The bottom of the TDA2500 module is a metal plate and serves as a heat sink for the internal MOSFET drivers. The temperature of this plate is directly related to the power dissipated in the output drivers. The power dissipated is broken up into two main areas, the VN12 power, and the power needed to charge the parasitic capacitances. These capacitances are internal to the MOSFET driver and the power to charge these comes from VPP and flows to VNN. Thus, as the supply voltage difference VPP-VNN increases, the amount of dissipation also increases.

Due to the increase possible supply voltage, the TDA2500 will run hotter than previous Tripath hybrids such as the TA0104A. Thus, depending on system airflow, and the actual power supply voltages, it may be necessary to attach an additional heat sink to the back plate or install a small fan to increase airflow directly around the hybrid. Of note, the back plate has a high impedance connection to VNN.

## TDA2500 AMPLIFIER GAIN

The gain of the TDA2500 is the product of the input stage gain and the modulator gain. Please refer to the sections, Input Stage Design, and Modulator Feedback Design, for a complete explanation of how to determine the external component values.

$$A_{VTDA2500} = A_{VINPUTSTAGE} * A_{VMODULATOR}$$

$$A_{VTDA2500} \approx -\frac{20k\ \Omega}{4.99k\ \Omega + R_I} \left( \frac{(1.0k\ \Omega + R_{FB}) * 2.02}{1020} + 1 \right)$$

For example, using a TDA2500 with the following external components,

$$R_I = 49.9k\ \Omega$$

$$R_{FB} = 18.7k\ \Omega$$

$$A_{VTDA2500} \approx -\frac{20k\ \Omega}{54.89k\ \Omega} \left( \frac{19.7k\ \Omega * 2.02}{1020} + 1 \right) = -14.58 \frac{V}{V}$$

## INPUT STAGE DESIGN

The TDA2500 input stage is an inverting amplifier, with a maximum gain of 4. Figure 2 shows a typical application where the input stage is a constant gain inverting amplifier. The input stage gain should be set so that the maximum input signal level will drive the input stage output to 4Vpp. Please note that the input is biased between V5 and AGND. Thus, the polarity of C<sub>1</sub> must be observed.

The gain of the input stage, above the low frequency high pass filter point, is that of a simple inverting amplifier:

$$A_{VINPUTSTAGE} = -\frac{20k\ \Omega}{4.99k\ \Omega + R_I}$$

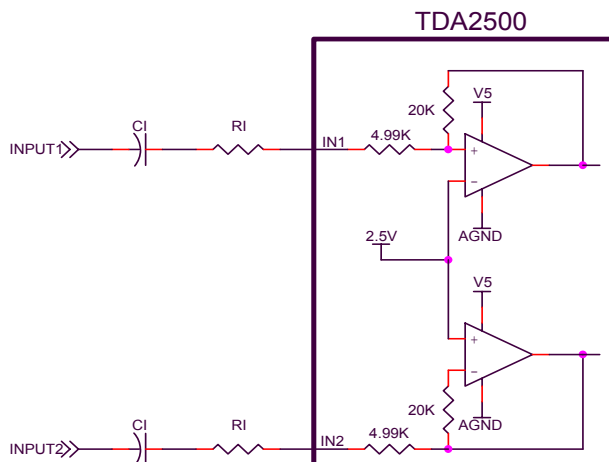

**Figure 2: Input Stage**

## INPUT CAPACITOR SELECTION

$C_I$  can be calculated once a value for  $R_{IN}$  has been determined.  $C_I$  and  $R_I$  determine the input low-frequency pole. Typically this pole is set at 10Hz.  $C_I$  is calculated according to:

$$C_I = 1 / (2\pi \times F_P \times R_I)$$

where:  $R_I$  = Input resistor value in ohms  
 $F_P$  = Input low frequency pole (typically less than 10Hz)

## MODULATOR FEEDBACK DESIGN

The modulator converts the signal from the input stage to the high-voltage output signal. The optimum gain of the modulator is determined from the maximum allowable feedback level for the modulator and maximum supply voltages for the power stage. Depending on the maximum supply voltage, the feedback ratio will need to be adjusted to maximize performance. The value of  $R_{FB}$ , in conjunction with resistors internal to the TDA2500 hybrid, (see explanation below) define the gain of the modulator. Once these values are chosen, based on the maximum supply voltage, the gain of the modulator will be fixed even as the supply voltage fluctuates due to current draw.

For the best signal-to-noise ratio and lowest distortion, the maximum modulator feedback voltage should be approximately 4.5Vpp. This will keep the gain of the modulator as low as possible and still allow headroom so that the feedback signal does not clip the modulator feedback stage. It should be noted that the modulator works over basically a 2:1 supply voltage ratio with optimum performance around 3.5Vpp-4Vpp of feedback. Thus, the actual value of  $R_{FB}$  may need to be adjusted from the typical value (39.2k $\Omega$ ) shown in the Application/Test Circuit to achieve maximum performance.

Figure 3 shows how the feedback from the output of the amplifier is returned to the input of the modulator. The input to the modulator (FDBKN1/GNDKELVIN1 for channel 1) can be viewed as inputs to an inverting differential amplifier. The internal 1k $\Omega$  and 1.02k $\Omega$  resistors bias the feedback signal to approximately 2.5V and  $R_{FB}$ , along with the internal series 1k $\Omega$ , scales the large output1 signal to down to approximately 4Vpp, depending on the supply voltage, VPP and VNN.

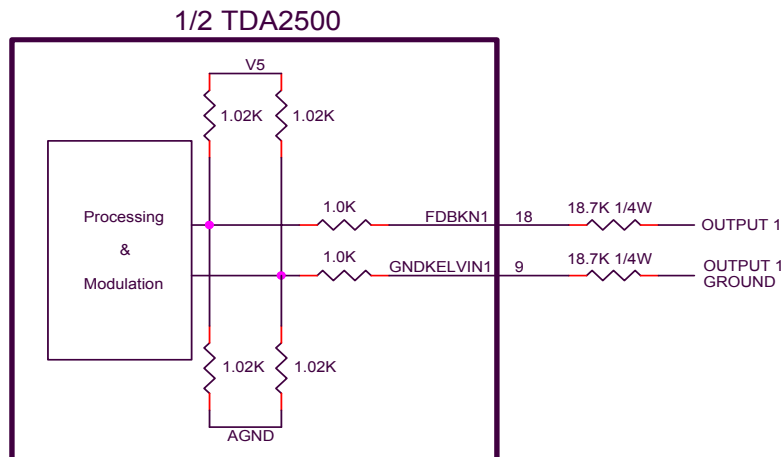

**Figure 3: Modulator Feedback**



The feedback resistors,  $R_{FB}$ , can be calculated using the following formula:

$$R_{FB} = \frac{1.0k\ \Omega * V_{PP}}{4.5} - 1.0k\ \Omega$$

The above equation assumes that  $V_{PP}=|V_{NN}|$ .

The gain of the modulator can be calculated using the following formula:

$$A_{V - MODULATOR} \approx \frac{(R_{FB} + 1.0k\ \Omega) * 2.02}{1020} + 1$$

For example, in a system with  $V_{PP_{MAX}}=90V$  and  $V_{NN_{MAX}}=-90V$ ,

$$R_{FB} = 19.0k\Omega, \text{ use } 18.7k\Omega, 1\%$$

The resultant modulator gain is:

$$A_{V - MODULATOR} \approx \frac{19.7k\ \Omega * 2.02}{1020} + 1 = 40.01V/V$$

## **MUTE**

When a logic high signal is supplied to MUTE, both amplifier channels are muted (both high- and low-side transistors are turned off). When a logic level low is supplied to MUTE, both amplifiers are fully operational. There is a delay of approximately 200 milliseconds between the de-assertion of MUTE and the un-muting of the TDA2500. Please note that when the amplifier is in mute, the outputs are in a high impedance state and thus, the feedback resistors will set the output at approximately 2.5V without a load connected.

To ensure proper device operation, including minimization of turn on/off transients that can result in undesirable audio artifacts, Tripath recommends that the TDA2500 device be muted prior to power up or power down of the 5V supply. The “sensing” of the V5 supply can be easily accomplished by using a “microcontroller supervisor” or equivalent to drive the TDA2500 mute pin high when the V5 voltage is below 4.5V. This will ensure proper operation of the TDA2500 input circuitry. A micro-controller supervisor such as the MCP101-450 from Microchip Corporation has been used by Tripath to implement clean power up/down operation.

## **HMUTE**

The HMUTE pin is a 5V logic output that indicates various fault conditions within the device. These conditions include: over-current, overvoltage and undervoltage. The HMUTE output is capable of directly driving an LED through a series 2k $\Omega$  resistor.

## **TURN-ON & TURN-OFF NOISE**

If turn-on or turn-off noise is present in a TDA2500 amplifier, the cause is frequently due to other circuitry external to the TDA2500. While the TDA2500 has circuitry to suppress turn-on and turn-off transients, the combination of the power supply and other audio circuitry with the TDA2500 in a particular application may exhibit audible transients. In addition, a non-trimmed output offset will create an audible click on turn-on and turn-off. One solution that will completely eliminate turn-on and turn-off pops and clicks (assuming a nulled output offset) is to use a relay to connect/disconnect the amplifier from the speakers with the appropriate timing at power on/off. The relay can also be used to protect the speakers from a component failure (e.g. shorted output MOSFET). “DC protection” circuitry would need to be implemented external to the TDA2500 to detect such failures.

As stated in the Mute section above, a common cause of turn off pops can be attributed to the 5V supply collapsing while the other supply rails are still present. On power down, mute should be activated (pulled high) before the power supplies, especially the 5V, begin to collapse. A microcontroller supervisor, now available from multiple manufacturers, is a good way to insure proper control of the mute during power supply sequencing.

### **DC OFFSET**

While the DC offset voltages that appear at the speaker terminals of a TDA2500 amplifier are typically small, Tripath recommends that any offsets during operation be nulled out of the amplifier with a circuit like the one shown connected to IN1 and IN2 in the Application/Test Circuit. It should be noted that the DC voltage on the output of a TDA2500 amplifier with no load in mute will not be zero. This offset does not need to be nulled. The output impedance of the amplifier in mute mode is approximately  $40K\Omega(R_F B + 1.0k\Omega)$ . This means that the DC voltage drops to essentially zero when a typical load is connected.

### **OVER-CURRENT PROTECTION**

The TDA2500 has over-current protection circuitry to protect itself and the output transistors from short-circuit conditions. The TDA2500 measures the voltage across a resistor,  $R_S$  (via OCSxHP, OCSxHN, OCSxLP and OCSxLN) that is in series with each output MOSFET to detect an over-current condition.  $R_S$  and  $R_{OCR}$  are used to set the over-current threshold. The OCS pins must be Kelvin connected for proper operation. This implies connecting a trace directly from the resistor lead to the respective sense pin. No other current or power supply connections should be made to the OCS pins of the TDA2500. Doing so will result in false overcurrent events due to the IR losses of the PCB trace. See "Circuit Board Layout" in Application Information for additional details.

When the voltage across  $R_{OCR}$  becomes greater than  $V_{TOC}$  (typically 0.97) the TDA2500 will shut off the output stages of its amplifiers. The occurrence of an over-current condition is latched in the TDA2500 and can be cleared by toggling the MUTE input or cycling power.

### **SETTING OVER-CURRENT THRESHOLD**

$R_S$  and  $R_{OCR}$  determine the value of the over-current threshold,  $I_{SC}$ :

$$I_{OC} = (4990 \times (V_{TOC} - I_{BIAS} \times R_{OCR})) / (R_{OCR} \times R_S)$$

$$R_{OCR} = (4990 \times V_{TOC}) / (I_{OC} \times R_S + 4990 \times I_{BIAS})$$

where:

$R_S$  and  $R_{OCR}$  are in  $\Omega$

$V_{TOC}$  = Over-current sense threshold voltage (See Electrical Characteristics Table)  
= 0.97V typically

	+/-60V	+/-70V	+/-80V	+/-90V
$I_{BIAS}$	30 $\mu$ A	32 $\mu$ A	33.5 $\mu$ A	34.5 $\mu$ A

**TABLE 1: Typical  $I_{BIAS}$  values for TDA2500**

For example, to set an  $I_{OC}$  of 20A using a +/-90V supply,  $R_{OCR} = 13.006K\Omega$  (use 13K $\Omega$ , 1%) and  $R_S$  will be 10m $\Omega$ .

As high-wattage resistors are usually only available in a few low-resistance values (10m $\Omega$ , 25m $\Omega$  and 50m $\Omega$ ),  $R_{OCR}$  can be used to adjust for a particular over-current threshold using one of these values for  $R_S$ .

It should be noted that the overcurrent trip level has a "duty cycle" dependence of roughly 2:1. This is due to the half-wave current detection (with some filtering) nature of the protection circuit implemented on the

TDA2500. Thus, a current limit into a “short” will produce a peak current level roughly twice that of an over-current into a 4 $\Omega$  (or higher) load. The calculation above is for an over current condition (driving a 4 $\Omega$  resistor for example). Thus, the peak current into a short will be roughly double of the calculation above.

### **AUXILLARY OVER-CURRENT DETECTION CIRCUITS**

As noted in the previous section, the current trip point into a short is roughly twice that of (requires very little output voltage swing) a load which produces a over current fault near the maximum voltage swing of the amplifier. In most cases, MOSFETs can withstand 3-4 times the rated continuous current for short durations (less than 100 $\mu$ S). Thus, for most situations this additional current does not cause any damage to the output MOSFETs and / or the TDA2500.

But in some cases, it may be desirable to have a more constant current trip point, i.e. a current trip that is constant across all ranges of duty cycle and output switching frequency. The RB-TDA2500 reference board shows one such circuit. This circuit augments the internal half-wave circuit to create a full wave circuit that has little or no duty cycle effect. Please refer to the RB-TDA2500 document at [www.tripath.com](http://www.tripath.com) for circuit details.

Instead, it may be desirable to create an entirely separate current detection circuit. Unlike previous hybrid modules from Tripath such as TA0104A and TA0105A, the internal comparators used in the detection process are directly connected to the OCR1 and OCR2 pins. As shown in the Electrical Characteristics table, the threshold for the comparator is 0.97V typically. Also, there is about 3 $\mu$ S of time-based deglitching. Thus, the comparator input has to be above 0.97V for 3 $\mu$ S to create an over-current fault.

This comparator input can be used to feed in a voltage from an external detection circuit. In this case, the detection circuit on the TDA2500 can be disabled by individually shorting each of the four OCSx pin pairs directly at the TDA2500.

### **OVER-VOLTAGE AND UNDER-VOLTAGE PROTECTION**

The TDA2500 senses the power rails through the VPP and VNN pins on the module. These voltages are converted to currents by internal (and typically external, also) resistor networks connected to VLOW and VHIGH. The over-voltage and under-voltage limits are determined by the internal bias currents, the values of the resistors in the networks, along with process variations. If the supply voltage falls outside the upper and lower limits determined by the resistor networks, the TDA2500 shuts off the output stages of the amplifiers. The removal of the over-voltage or under-voltage condition returns the TDA2500 to normal operation. Please note that trip points specified in the Electrical Characteristics table are at 25 $^{\circ}$ C and may change over temperature.

Once the supply comes back into the supply voltage operating range (as defined by the power supply sense resistors), the TDA2500 will automatically be un-muted and resume amplification. There is a hysteresis range on both the VPP and VNN supplies. If the amplifier is powered up in the hysteresis band, the TDA2500 will be muted. Thus, the usable supply range is the difference between the over-voltage restart and under-voltage restart points for both the VPP and VNN supplies. It should be noted that there is a timer of approximately 200mS with respect to the over and under voltage sensing circuit. Thus, the supply voltage must be outside of the user defined supply range for greater than 200mS for the TDA2500 to be muted.

The over-voltage and under-voltage resistor values were chosen for the maximum supply range possible based on the internal hybrid components in conjunction with internal bias current settings. In most applications using the TDA2500, external resistors will be used to lower the supply range for VPP and VNN. The delta between each of the trip points is a fixed ratio and not externally controllable. The current flowing into VHIGH controls the supply range for VPP while the current flowing out of VLOW controls the supply range for VNN.

Figure 4 shows the proper connection for the Over / Under voltage sense circuit for both the VPPSENSE and VNNSENSE pins.

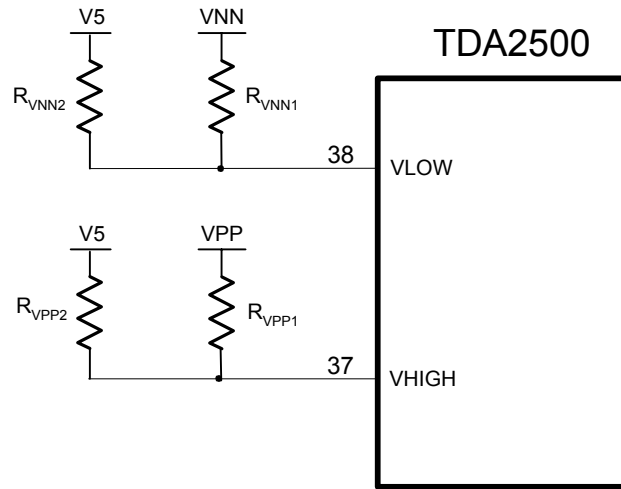

**Figure 4: Over / Under voltage sense circuit**

The procedure for shifting the VPP range is as follows:

- 1) Choose the minimum VPP over-voltage reset point,  $VPP_{OVRSTMIN}$
- 2) Use the following equation to calculate the external parallel resistor,  $R_{VPP1}$

$$R_{VPP1} = \frac{1.4M\Omega * VPP_{OVRSTMIN}}{193.2V - VPP_{OVRSTMIN}}$$

Set  $R_{VPP2} = R_{VPP1}$

- 3) Use the following equation to calculate the resulting maximum VPP under-voltage restart point,  $VPP_{UVRSTMAX}$

$$VPP_{UVRSTMAX} = 87\mu A * (R_{VPP1} || 1.4M\Omega)$$

The usable (inside the hysteresis band) positive supply range is defined by  $VPP_{OVRSTMIN}$  minus  $VPP_{UVRSTMAX}$ .

A similar procedure for shifting the VNN range is as follows.

- 1) Choose the minimum VNN over-voltage reset point,  $VNN_{OVRSTMIN}$
- 2) Use the following equation to calculate the external parallel resistor,  $R_{VNN1}$

$$R_{VNN1} = \frac{1.27M\Omega * VNN_{OVRSTMIN}}{193.04V - VNN_{OVRSTMIN}}$$

Set  $R_{VNN2} = 3 * R_{VNN1}$

- 3) Use the following equation to calculate the resulting maximum VNN under-voltage restart point,  $VNN_{UVRSTMAX}$

$$VNN_{UVRSTMAX} = 95\mu A * (R_{VNN1} || 1.27M\Omega)$$

The usable (inside the hysteresis band) negative supply range is defined by  $VNN_{OVRSTMIN}$  minus  $VNN_{UVRSTMAX}$ .

Please note that the formulas above do not take into consideration the resistor tolerance. One percent resistors should be used to minimize any variance with respect to the above formulas. Five percent and ten percent resistors are not recommended for shifting the supply range as the resistor variance will cause the usable supply range to shrink.

### VN12 SUPPLY

VN12 is an additional supply voltage required by the TDA2500. VN12 must be 12 volts more positive than the nominal VNN. VN12 must track VNN. Generating the VN12 supply requires some care.

The proper way to generate the voltage for VN12 is to use a 12V-positive supply voltage referenced to the VNN supply. Figure 5 shows the correct way to power the TDA2500.

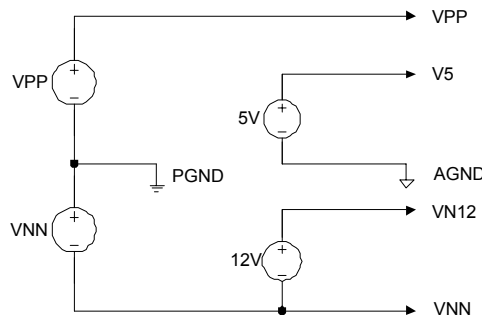

**Figure 5: Proper Power Supply Connection**

One apparent method to generate the VN12 supply voltage is to use a negative IC regulator to drop PGND down to 12V (relative to VNN). This method will not work since negative regulators only sink current into the regulator output and will not be capable of sourcing the current required by VN12. Furthermore, problems will arise since VN12 will not track movements in VNN.

A common approach is to use an additional secondary on the power transformer to generate an isolated, say 15VAC voltage. This AC voltage is then full bridge rectified and filtered to produce a DC input voltage for a LM7812 or similar. The “ground” of the LM7812 is then connected to VNN and thus VN12 will be properly referenced. Please refer to Figure 6.

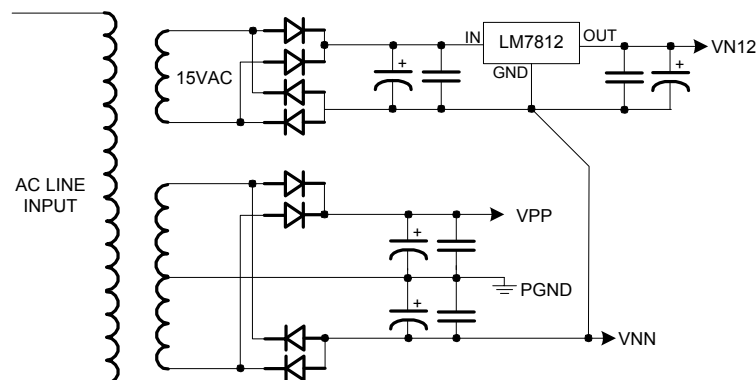

**Figure 6: Proper VN12 Supply Generation**

## **OUTPUT TRANSISTOR SELECTION**

The key parameters to consider when selecting what MOSFET to use with the TDA2500 are drain-source breakdown voltage ( $BV_{dss}$ ), gate charge ( $Q_g$ ), and on-resistance ( $R_{DS(ON)}$ ).

The  $BV_{dss}$  rating of the MOSFET needs to be selected to accommodate the voltage swing between  $V_{SPOS}$  and  $V_{SNEG}$  as well as any voltage peaks caused by voltage ringing due to switching transients. With a 'good' circuit board layout, a  $BV_{dss}$  that is 20% higher than the  $V_{PP}$  and  $V_{NN}$  voltage swing is a reasonable starting point. The  $BV_{dss}$  rating should be verified by measuring the actual voltages experienced by the MOSFET in the final circuit. Thus, for TDA2500 "typical" applications a mosfet with 200V rating is required.

Ideally a low  $Q_g$  (total gate charge) and low  $R_{DS(ON)}$  are desired for the best amplifier performance. Unfortunately, these are conflicting requirements since  $R_{DS(ON)}$  is inversely proportional to  $Q_g$  for a typical MOSFET. The design trade-off is one of cost versus performance. A lower  $R_{DS(ON)}$  means lower  $I^2R_{DS(ON)}$  losses but the associated higher  $Q_g$  translates into higher switching losses (losses =  $Q_g \times 12 \times 700\text{kHz}$ ). A lower  $R_{DS(ON)}$  also means a larger silicon die and higher cost. A higher  $R_{DS(ON)}$  means lower cost and lower switching losses but higher  $I^2R_{DS(ON)}$  losses.

The following table lists  $BV_{dss}$ ,  $Q_g$  and  $R_{DS(ON)}$  for MOSFETs that Tripath has used with the TDA2500.

Part Number	Manufacturer	$BV_{dss}$ (V)	$I_D$ (A)	$Q_g$ (nC)	$R_{DS(on)}$ ( $\Omega$ )	$P_D$ (W)	Package
STW34NB20	ST Microelectronics	200	34	60	0.062	180	TO247
STW50NB20	ST Microelectronics	200	50	84	0.047	280	TO247
STW20NM50FD	ST Microelectronics	500	20	38	0.22	214	TO247
STW18NB40	ST Microelectronics	400	18.4	60	0.19	190	TO247

## **GATE RESISTOR SELECTION**

The gate resistors,  $R_G$ , are used to control MOSFET switching rise/fall times and thereby minimize voltage overshoots. They also dissipate a portion of the power resulting from moving the gate charge each time the MOSFET is switched. If  $R_G$  is too small, excessive heat can be generated in the driver. Large gate resistors lead to slower MOSFET switching, which requires a larger break-before-make (BBM) delay.

In addition, a Schottky or ultra-fast PN junction diode can be used in parallel with the gate resistor. The anode of the diode is connected to the MOSFET gate. This diode serves to "speed up" the turn-off of the output devices further reducing cross conduction and minimizing output stage idle current.

A typical gate resistor value for the mosfets recommended above is 3.3 – 5.6ohms. The value of the gate resistor needs to be lowered as the gate charge of the output fets is increased so as to maintain a reasonable idle current. As mentioned earlier, the use of gate diodes will further reduce the idle current for a given value of gate

## **BREAK-BEFORE-MAKE (BBM) TIMING CONTROL**

The half-bridge power MOSFETs require a deadtime between when one transistor is turned off and the other is turned on (break-before-make) in order to minimize shoot through currents. BBM0 and BBM1 are logic inputs (connected to logic high or pulled down to logic low) that control the break-before-make timing of the output transistors according to the following table.

BBM1	BBM0	Delay
0	0	145 ns
0	1	105 ns
1	0	65 ns
1	1	25 ns

**Table 2: BBM Delay**

The tradeoff involved in making this setting is that as the delay is reduced, distortion levels improve but shoot-through and power dissipation increase. The actual amount of BBM required is dependent upon components such as MOSFET type and gate resistor value as well as circuit board layout. The BBM value selected should be verified in the actual application circuit board. It should also be verified under maximum temperature and power conditions since shoot-through in the output MOSFETs can increase under these conditions, possibly requiring a higher BBM setting than at room temperature.

## **OUTPUT FILTER DESIGN**

One advantage of Tripath amplifiers over PWM solutions is the ability to use higher-cutoff-frequency filters. This means load-dependent peaking/droop in the 20kHz audio band potentially caused by the filter can be made negligible. Furthermore, speakers are not purely resistive loads and the impedance they present changes over frequency and from speaker model to speaker model.

Tripath recommends designing the filter as a 2nd order, LC filter. Tripath has obtained good results with  $L_O = 11\mu\text{H}$  and  $C_O = 0.22\mu\text{F}$  (resonant frequency of 59kHz). The filter capacitor must be able of sustain the ripple current caused by the high frequency switching. Thus, a high quality film capacitor is strongly recommended.

The typical application of the TDA2500 is driving “high impedance” loads from 12.5 ohms and above. This dictates the use of a larger value output inductor,  $L_O$ , as compared to other Tripath amplifiers to minimize in band output filter peaking and match better to the intended load impedance.

There is a compromise between inductor value and amplifier efficiency. Tripath amplifiers count on the inductor current making “free” transitions. Take the case where the inductor current is flowing out towards the load. This is the case where there is a positive going output waveform. When the top side device turns off, the output voltage will “flip” to keep the inductor current in the same direction. If the entire transition of the output voltage (from  $V_{PP}$  to  $V_{NN}$ ) occurs before the bottom side device is enhanced, then the transition is free. This has a positive effect on amplifier efficiency. If the bottom side device turns on before the transition is completed then power is wasted and the amplifier efficiency suffers. The output transition time is directly proportional to the inductor value and the supply voltage. Thus, larger values of inductance (for a given fet output capacitance) will result in longer transition times and decreased efficiency for a fixed supply rail. The value of  $L_O$ , 33 $\mu\text{H}$ , recommended above was chosen as a reasonable compromise between efficiency and load “damping.” An upper bound on  $L_O$  without totally sacrificing efficiency, is 47 $\mu\text{H}$  for typical TDA2500 supply voltages and the STW20NM50FD fets. Above this value, the designer should fully characterize the amplifier efficiency before settling on the inductor value. The peaking exhibited by a lightly loaded LC filter can be equalized out (to some degree) by an input RC filter located before the input coupling capacitor,  $C_I$ . This will result in a flatter magnitude response over a wider range of output loads. In addition, it will provide additional protection (beyond that provided by the zobel network) against high frequency signals that can cause the output filter to resonate.

The core material of the output filter inductor has an effect on the distortion levels produced by a TDA2500 amplifier. Tripath recommends low-mu type-2 iron powder cores because of their low loss and high linearity (available from Micrometals, [www.micrometals.com](http://www.micrometals.com)). The specific core used on the RB-TDA2500 was a T106-2 wound with 29 turns of 16AWG wire.

Tripath also recommends that an RC damper be used after the LC low-pass filter. No-load operation of a TDA2500 amplifier can create significant peaking in the LC filter, which produces strong resonant

currents that can overheat the output MOSFETs and other components. The RC dampens the peaking and prevents problems. Tripath has obtained good results with  $R_D = 15\Omega$  and  $C_D = 0.22\mu F$ . The zobel resistor must be able to dissipate the power of the LC resonance as well as the remainder of high frequency energy that passes through the LC filter. A typical power rating for this resistor is 10W. The zobel resistor power capability will need to be increased if the application requires full power at 20kHz. The zobel capacitor must be able to sustain the ripple current caused by the high frequency switching. Thus, a high quality film capacitor is recommended.

### **LOW-FREQUENCY POWER SUPPLY PUMPING**

A potentially troublesome phenomenon in single-ended switching amplifiers is power supply pumping. This phenomenon is caused by current from the output filter inductor flowing into the power supply output filter capacitors in the opposite direction as a DC load would drain current from them. Under certain conditions (usually low-frequency input signals), this current can cause the supply voltage to “pump” (increase in magnitude) and eventually cause over-voltage/under-voltage shut down. Moreover, since over/under-voltage are not “latched” shutdowns, the effect would be an amplifier that oscillates between on and off states. If a DC offset on the order of 0.3V is allowed to develop on the output of the amplifier (see “DC Offset Adjust”), the supplies can be boosted to the point where the amplifier’s over-voltage protection triggers.

One solution to the pumping issue is to use large power supply capacitors to absorb the pumped supply current without significant voltage boost. The low-frequency pole used at the input to the amplifier determines the value of the capacitor required. This works for AC signals only.

A no-cost solution to the pumping problem uses the fact that music has low frequency information that is correlated in both channels (it is in phase). This information can be used to eliminate boost by putting the two channels of a TDA2500 amplifier out of phase with each other. This works because each channel is pumping out of phase with the other, and the net effect is a cancellation of pumping currents in the power supply. The phase of the audio signals needs to be corrected by connecting one of the speakers in the opposite polarity as the other channel.

### **PERFORMANCE MEASUREMENTS OF A TDA2500 AMPLIFIER**

Tripath amplifiers operate by modulating the input signal with a high-frequency switching pattern. This signal is sent through a low-pass filter (external to the TDA2500) that demodulates it to recover an amplified version of the audio input. The frequency of the switching pattern is spread spectrum and typically varies between 200kHz and 1.5MHz, which is well above the 20Hz – 22kHz audio band. The pattern itself does not alter or distort the audio input signal but it does introduce some inaudible noise components.

The measurements of certain performance parameters, particularly those that have anything to do with noise, like THD+N, are significantly affected by the design of the low-pass filter used on the output of the TDA2500 and also the bandwidth setting of the measurement instrument used. Unless the filter has a very sharp roll-off just past the audio band or the bandwidth of the measurement instrument ends there, some of the inaudible noise components introduced by the Tripath amplifier switching pattern will get integrated into the measurement, degrading it.

Tripath amplifiers do not require large multi-pole filters to achieve excellent performance in listening tests, usually a more critical factor than performance measurements. Though using a multi-pole filter may remove high-frequency noise and improve THD+N type measurements (when they are made with wide-bandwidth measuring equipment), these same filters can increase distortion due to inductor non-linearity. Multi-pole filters require relatively large inductors, and inductor non-linearity increases with inductor value.

### **REPLACING A TA0105A WITH A TDA2500 FOR LOW IMPEDANCE APPLICATIONS**

The TDA2500 is structurally very similar to the TA0105A. The primary application of the TA0105A is constant voltage amplifiers (70V / 100V) as opposed to amplifiers capable of driving low impedance speaker loads (for example 4 – 8 nominal impedances). Prior to the availability of the TDA2500, many



applications used the TA0105A in applications that had used the TA0102A, TA0103A and TA0104A, prior.

It is recommended that customers using the TA0105A for low impedance drive convert to the TDA2500. The main reason for this is improved over-current circuit linearity, especially at lower supply voltages as well as the possibility of implementing an external over-current circuit to augment the internal half-wave detection circuit.

For a given TA0105A low impedance application, the only components that require changing are the  $R_{OCR}$  values. The values of  $R_{FB}$ ,  $R_{VPP1}$ ,  $R_{VPP2}$ ,  $R_{VNN1}$ , and  $R_{VNN2}$  are constant for a given TA0105A design as compared to a TDA2500 design.

The procedure to determine the TDA2500 ROCR value is as follows:

- 1) Calculate the  $I_{OC}$  point of the TA0105A design using  $R_{OCR}$ ,  $R_S$ ,  $V_{TOC} = 0.97V$  and  $I_{BIAS}$  of 15 $\mu A$ .

For example, given  $R_{OCR} = 8.45K\Omega$  and  $R_S = 0.01\Omega$

$$I_{OC} = 4990 \times (V_{TOC} - I_{BIAS} \times (9100 + R_{OCR})) / ((9100 + R_{OCR}) \times R_S)$$

(formula from the TA0105A data sheet)

$$I_{OC} = 4990 \times (0.97V - 15\mu A \times (9100\Omega + 8450\Omega)) / ((9100\Omega + 8450\Omega) \times 0.01\Omega) = 20.10 A$$

- 2) Calculate the required  $R_{OCR}$  value for the TDA2500 using the TA0105A  $I_{OC}$  value from step 1.

Given  $I_{OC} = 20.10A$ ,  $R_S = 0.01\Omega$ ,  $V_{TOC} = 0.97V$  and  $I_{BIAS} = 34.5\mu A$  (bias value assumes +/-90V operation)

$$R_{OCR} = (4990 \times V_{TOC}) / (I_{OC} \times R_S + 4990 \times I_{BIAS})$$

(formula from the TDA2500 data sheet)

$$R_{OCR} = (4990 \times 0.97V) / (20.10A \times 0.01\Omega + 4990 \times 34.5\mu A) = 12.97k\Omega$$

Use nearest 1% resistor value for  $R_{OCR}$ .

For this example, the proper choice is 13.0k $\Omega$ , 1%.

## **EMULATING LEGACY TRIPATH MODULES USING A TDA2500 MODULE**

The TDA2500 is structurally very similar to legacy hybrid modules such as TA0102A, TA0103A and TA0104A. All of these modules employ the same block diagram. Items such as modulator gain and supply range were fixed on the TA0102A, TA0103A and TA0104A. These items are adjustable on the TDA2500. Thus, by choosing the proper value of external components that control these features, the TDA2500 can emulate any of the legacy modules. The voltage rating on the TDA2500 hybrid components are 200V, thus operating at lower voltages does not cause any problem assuming that the external, user selectable, components are properly chosen.

For ease of use, the "voltage shifting" components are external to the TDA2500, allowing the user to choose the voltage range, depending on the specific application. The most typical application is emulating a TA0104A with its associated gain and voltage range. Below is a list of instructions along with diagrams of the modifications needed to implement a "TA0104A" design. It should be noted that if some intermediate range is needed, that the feedback and overvoltage/undervoltage resistors can be adjusted based on the equations given in previous sections of the Application Information.

- Change the feedback resistors,  $R_{FB}$ , to 18.7K, 1/4W. This requires a total of four resistors (2 per channel) as both the FDBKNx and GNDKELVINx nodes need to have the series resistors

inserted. This scales the amplifier feedback properly for the TA0104A supply range and results in the same gain as a standard TA0104A design. The resulting gain equation is as follows. The modifications needed for channel 1 are shown in Figure 7.

$$A_v \approx - \frac{20k \Omega}{4.99k \Omega + R_I} \left( \frac{19.7k * 2.02}{1020} + 1 \right)$$

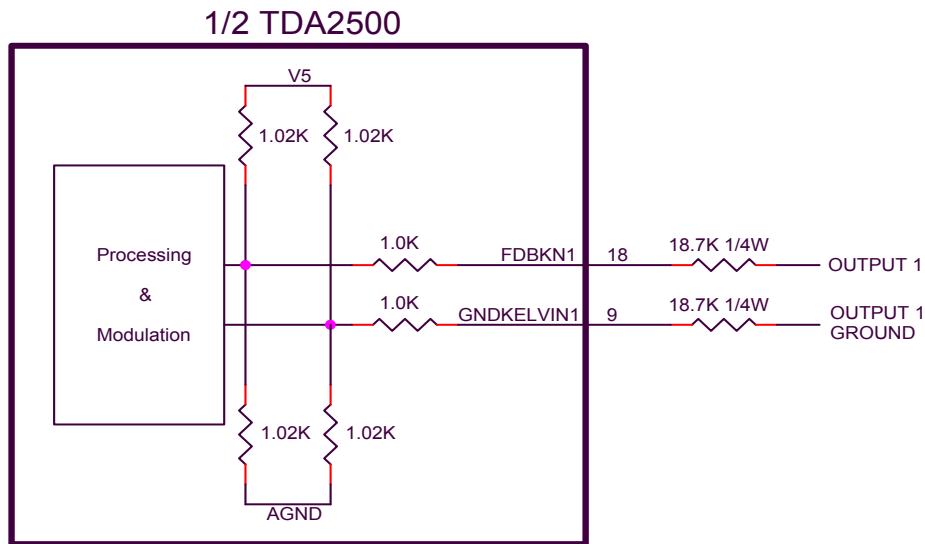

**Figure 7: Feedback Structure for TA0104A Emulation**

- Add the resistor dividers to both VLOW and VHIGH as shown in Figure 8. These resistors lower the supply range of the TDA2500 to roughly +/-60V to +/-93V, with a maximum undervoltage turn on voltage of +/-55V, assuming worse case tolerances. It should be noted that the TA0104A voltage specification of +/-55V to +/-92V were the undervoltage and overvoltage turn on points, not the inner hysteresis band. The "hot side" of the VNN and VPP resistors should be connected to pin 24 and pin 23, respectively. Surface mount types can be used (1/8W is fine) though the resistors need to 1% tolerance. Please note that the recommended resistor values are slightly different than those used in the TA0104A. This was done intentionally to produce a symmetrical supply range for VPP and VNN.

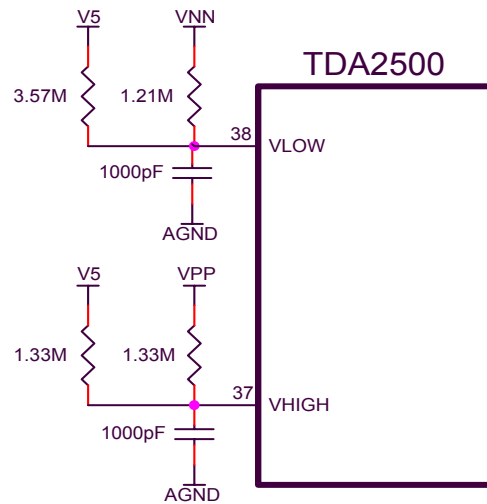

**Figure 8: Voltage Supply Sensing Structure for TA0104A Emulation**

- To maintain the same current trip point for the TA010xA based design, simply add 9.1k to the value of  $R_{OCR}$  used in the legacy design. Thus, if a 10kohm  $R_{OCR}$  was used for a TA0104A design, use 19.1k for each  $R_{OCR}$  resistor in the TDA2500 design.
- Add the 1000pF capacitors ( $C_{VB}$ ). These capacitors stabilize the sensing circuit resulting in repeatable voltage trip points. Please note that the return point is to analog ground (pin 1 on the TDA2500).
- The values of  $C_{FB}$  should be reevaluated. It is likely that the value for channel 2 will need to be increased as compared to the previous TA0104A design due to slightly different internal compensation. For best performance make sure that the difference between the two channels idle switching frequency is greater than 40kHz. In addition, make sure that the idle switching frequency of both channels is maintained above 575kHz.
- Other components such as output filter values, MOSFET type, gate resistor values, etc. should remain unchanged from the TA0104A design. Typical output filter components are 11uH, 0.22uF along with appropriate zobel compensation (15ohm/5W and 0.22uF). Typical MOSFET choice is the STW34NB20 or similar along with 5.6ohm gate resistors.
- It is highly recommended that the supply bypassing ( $C_{HBR}$ ) and diode ( $D_O$ ) clamping structure shown in the Application/Test circuit is utilized for new designs. This structure has been shown to minimize output node transients during high current events and will result in a more robust design.

The description above should be followed for TA0102A or TA0103A emulation with the exception of the following component value changes noted in the Table 3.

TDA2500 APPLICATION VALUES					
DEVICE	$R_{FB}$	$R_{VPP1}$	$R_{VPP2}$	$R_{VNN1}$	$R_{VNN2}$
TA0102A	9.1k, 1%	487k, 1%	487k, 1%	442k, 1%	1.33M, 1%
TA0103A	12.7k, 1%	649k, 1%	649k, 1%	590k, 1%	1.78M, 1%

**TABLE 3: External component values for TA0102A and TA0103A emulation**

## Package Information

### 38 Pin Quad Module

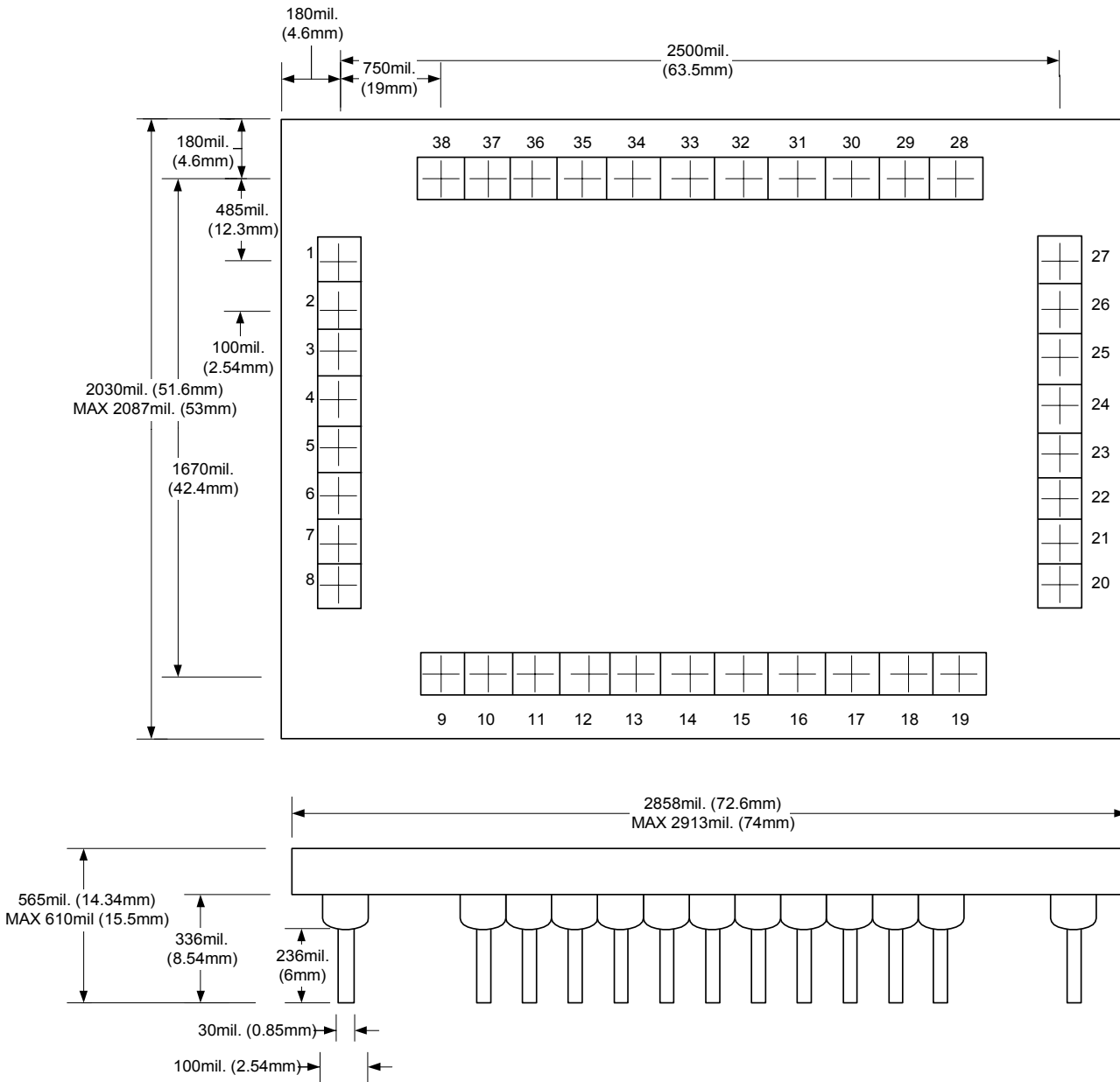

Phyco Socket: 4150-1 x 8SF1 8 position header female  
 4150-1 x 1SF1 11 position header female

Tripath and Digital Power Processing are trademarks of Tripath Technology Inc. Other trademarks referenced in this document are owned by their respective companies.

Tripath Technology Inc. reserves the right to make changes without further notice to any products herein to improve reliability, function or design. Tripath does not assume any liability arising out of the application or use of any product or circuit described herein; neither does it convey any license under its patent rights, nor the rights of others.

TRIPATH'S PRODUCTS ARE NOT AUTHORIZED FOR USE AS CRITICAL COMPONENTS IN LIFE SUPPORT DEVICES OR SYSTEMS WITHOUT THE EXPRESS WRITTEN CONSENT OF THE PRESIDENT OF TRIPATH TECHNOLOGY INC.

As used herein:

1. Life support devices or systems are devices or systems which, (a) are intended for surgical implant into the body, or (b) support or sustain life, and whose failure to perform, when properly used in accordance with instructions for use provided in this labeling, can be reasonably expected to result in significant injury to the user.
2. A critical component is any component of a life support device or system whose failure to perform can be reasonably expected to cause the failure of the life support device or system, or to affect its safety or effectiveness.

## Contact Information

### **TRIPATH TECHNOLOGY, INC**

2560 Orchard Parkway, San Jose, CA 95131  
408.750.3000 - P  
408.750.3001 - F

For more Sales Information, please visit us @ [www.tripath.com/cont\\_s.htm](http://www.tripath.com/cont_s.htm)  
For more Technical Information, please visit us @ [www.tripath.com/data.htm](http://www.tripath.com/data.htm)