

INTEGRATED CIRCUITS

DATA SHEET

TDA3608Q

Multiple voltage regulator with switch

Preliminary specification
File under Integrated Circuits, IC01

1997 Aug 14

Multiple voltage regulator with switch

TDA3608Q

FEATURES

General

- Two V_P -state controlled regulators (regulator 1 and 3) and a power switch
- Regulator 2 and reset operate during load dump and thermal shutdown
- Separate control pins for switching regulator 1, regulator 3 and the power switch
- Supply voltage range of -18 to $+50$ V
- Low reverse current of regulator 2
- Low quiescent current (when regulator 1, regulator 3, and power switch are switched off)
- Hold output (only valid when regulator 1 is switched on)
- Reset and hold outputs (open collector outputs)
- Adjustable reset delay time
- High ripple rejection
- Back-up capacitor for regulator 2.

Protections

- Reverse polarity safe (down to -18 V without high reverse current)
- Able to withstand voltages up to 18 V at the outputs (supply line may be short-circuited)
- ESD protected on all pins
- Thermal protection
- Load dump protection
- Foldback current limit protection for regulators 1, 2 and 3
- Delayed second current limit protection for the power switch (at short-circuit)
- The regulator outputs and the power switch are DC short-circuited safe to ground and V_P .

GENERAL DESCRIPTION

The TDA3608Q is a multiple output voltage regulator with a power switch, intended for use in car radios with or without a microcontroller. It contains:

- Two fixed voltage regulators with a foldback current protection (regulator 1 and regulator 3) and one fixed voltage regulator (regulator 2), intended to supply a microcontroller, that also operates during load dump and thermal shutdown.
- A power switch with protections, operated by an enable input
- Reset and hold outputs that can be used to interface by the microcontroller. The reset signal can be used to call up the microcontroller and the hold output indicates regulator 1 voltage available and within range.
- A supply pin which can withstand load dump pulses and negative supply voltages
- Regulator 2 that will be switched on at a back-up voltage higher than 6.5 V and off when the output voltage of regulator 2 drops below 1.9 V
- A provision for use of a reserve supply capacitor that will hold enough energy for regulator 2 (5 V continuous) to allow a microcontroller to prepare for loss of voltage.

ORDERING INFORMATION

TYPE NUMBER	PACKAGE		
	NAME	DESCRIPTION	VERSION
TDA3608Q	DBS13P	plastic DIL-bent-SIL power package; 13 leads (lead length 12 mm)	SOT141-6

Multiple voltage regulator with switch

TDA3608Q

QUICK REFERENCE DATA

SYMBOL	PARAMETER	CONDITIONS	MIN.	TYP.	MAX.	UNIT
Supply						
V _P	supply voltage		9.5	14.4	18	V
	operating					
	reverse polarity	non-operating	–	–	–18	V
	regulator 2 on		2.4	14.4	50	V
	jump start	t ≤ 10 minutes	–	–	30	V
	load dump protection	t ≤ 50 ms; t _r ≥ 2.5 ms	–	–	50	V
I _{q(tot)}	total quiescent supply current	standby mode	–	500	600	μA
T _j	junction temperature		–	–	150	°C
Voltage regulators						
V _{O(REG1)}	output voltage regulator 1	1 mA ≤ I _{REG1} ≤ 600 mA	8.15	8.5	8.85	V
V _{O(REG2)}	output voltage regulator 2	0.5 mA ≤ I _{REG2} ≤ 300 mA; V _P = 14.4 V	4.75	5.0	5.25	V
V _{O(REG3)}	output voltage regulator 3	1 mA ≤ I _{REG3} ≤ 400 mA	4.75	5.0	5.25	V
Power switch						
V _d	drop-out voltage	I _{SW} = 1 A	–	0.45	0.7	V
		I _{SW} = 1.8 A	–	1	1.8	V
I _M	peak current		3	–	–	A

Multiple voltage regulator with switch

TDA3608Q

BLOCK DIAGRAM

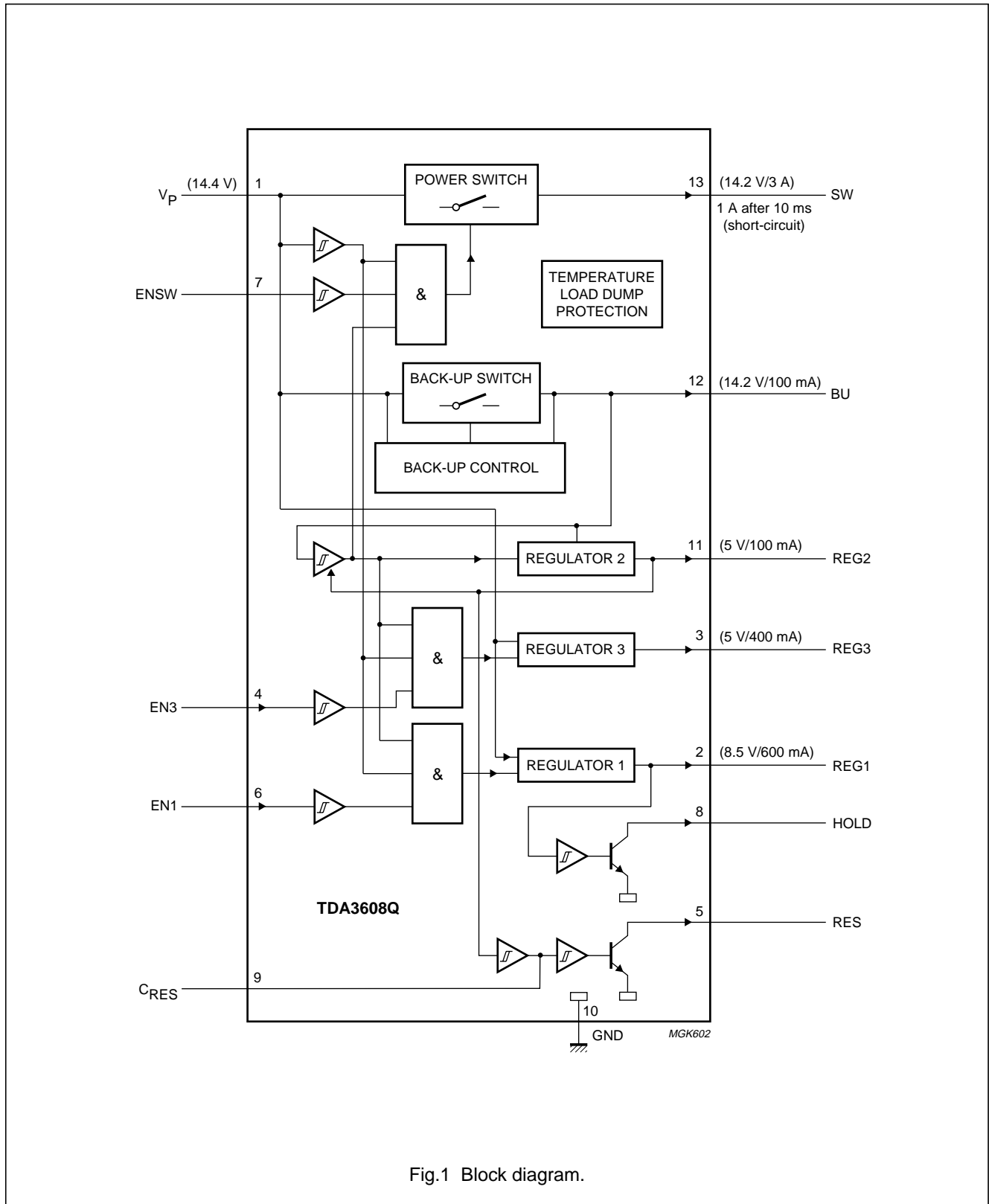

Fig.1 Block diagram.

Multiple voltage regulator with switch

TDA3608Q

PINNING

SYMBOL	PIN	DESCRIPTION
V_P	1	supply voltage
REG1	2	regulator 1 output
REG3	3	regulator 3 output
EN3	4	enable input regulator 3
RES	5	reset output
EN1	6	enable input regulator 1
ENSW	7	enable input power switch
HOLD	8	hold output
C_{RES}	9	reset delay capacitor
GND	10	ground
REG2	11	regulator 2 output
BU	12	back-up
SW	13	power switch output

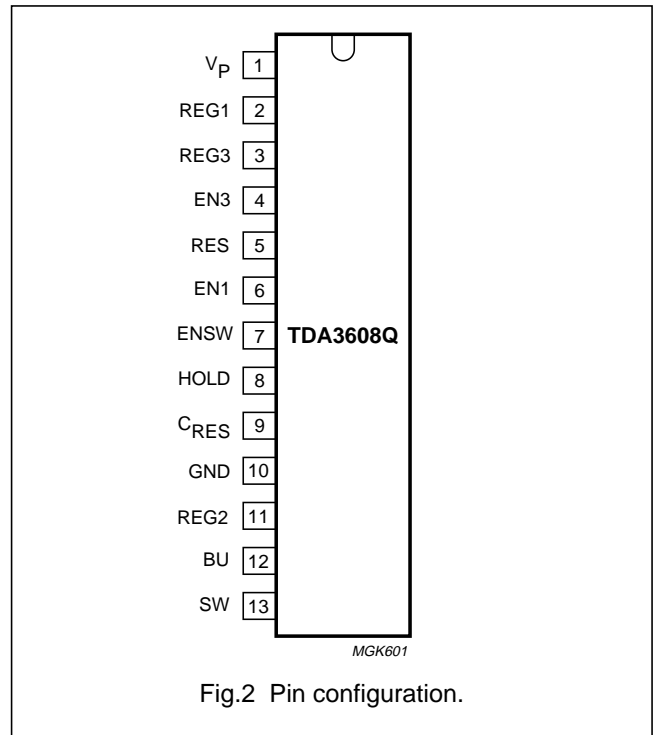

FUNCTIONAL DESCRIPTION

The TDA3608Q is a multiple output voltage regulator with a power switch, intended for use in car radios with or without a microcontroller. Because of low-voltage operation of the car radio, low-voltage drop regulators are used in the TDA3608Q.

Regulator 2 will switch on when the back-up voltage exceeds 6.5 V for the first time and will switch off again when the output voltage of regulator 2 drops below 1.9 V (this is far below an engine start). When regulator 2 is switched on and the output voltage of this regulator is within its voltage range, the reset output will be enabled (reset will go HIGH via a pull-up resistor) to generate a reset to the microcontroller. The reset cycles can be extended by an external capacitor at pin 9. The above mentioned start-up feature is built-in to secure a smooth start-up of the microcontroller at first connection, without uncontrolled switching of regulator 2 during the start-up sequence.

The charge of the back-up capacitor can be used to supply regulator 2 for a short period when the supply falls down to 0 V (time depends on value of storage capacitor). When regulator 2 and the supply voltage ($V_P > 4.5$ V) are both available, regulators 1 and 3 can be operated by means of enable inputs (pins 6 and 4 respectively).

Regulator 1 has a hold output (open collector) indicating that the output voltage of this regulator is settled (held HIGH by external pull-up resistor) and when the output voltage of this regulator drops out of regulation (because of supply voltage drop or high load) the hold output will go LOW. The hold output signal is only valid when regulator 1 is enabled by its enable input (pin 6).

The power switch can also be controlled by means of a separate enable input (pin 7) as shown in Fig.3 for the behaviour of the power switch output.

All output pins are fully protected. The regulators are protected against load dump (regulators 1 and 3 will switch off at supply voltages >18 V) and short-circuit (foldback current protection).

The power switch contains a current protection, but this protection is delayed at short-circuit condition for at least 10 ms. During this time the output current is limited to a peak value of at least 3 A and 2 A continuous ($V_P \leq 18$ V). At supply voltages >17 V the power switch is clamped at maximum 16 V (to avoid external connected circuitry being damaged by an overvoltage) and the power switch will switch off at load dump.

The total timing diagram is shown in Fig.3.

Multiple voltage regulator with switch

TDA3608Q

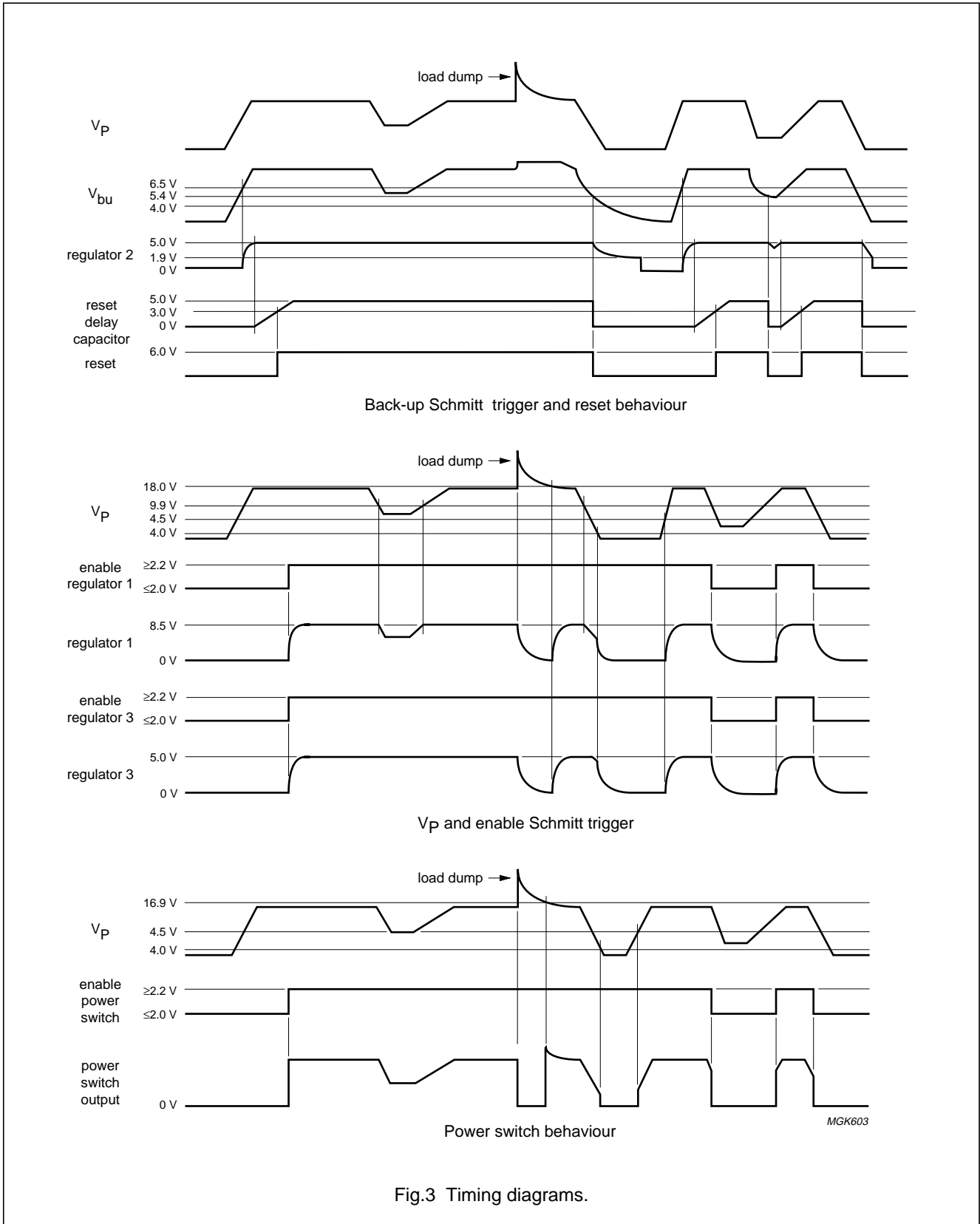

Fig.3 Timing diagrams.

Multiple voltage regulator with switch

TDA3608Q

LIMITING VALUES

In accordance with the Absolute Maximum Rating System (IEC 134).

SYMBOL	PARAMETER	CONDITIONS	MIN.	MAX.	UNIT
V _P	supply voltage		–	18	V
	operating		–	18	V
	reverse polarity	non-operating	–	–18	V
	jump start	t ≤ 10 minutes	–	30	V
	load dump protection	t ≤ 50 ms; t _r ≥ 2.5 ms	–	50	V
P _{tot}	total power dissipation		–	62	W
T _{stg}	storage temperature	non-operating	–55	+150	°C
T _{amb}	ambient temperature	operating	–40	+85	°C
T _j	junction temperature	operating	–40	+150	°C

THERMAL CHARACTERISTICS

SYMBOL	PARAMETER	CONDITIONS	VALUE	UNIT
R _{th(j-c)}	thermal resistance from junction to case		2	K/W
R _{th(j-a)}	thermal resistance from junction to ambient	in free air	50	K/W

Multiple voltage regulator with switch

TDA3608Q

CHARACTERISTICS

$V_P = 14.4\text{ V}$; $T_{\text{amb}} = 25\text{ °C}$; see Fig.6; unless otherwise specified.

SYMBOL	PARAMETER	CONDITIONS	MIN.	TYP.	MAX.	UNIT
Supply						
V_P	supply voltage		9.5	14.4	18	V
	operating regulator 2 on	note 1	2.4	14.4	18	V
	jump start	$t \leq 10$ minutes	–	–	30	V
	load dump protection	$t \leq 50\text{ ms}$; $t_r \geq 2.5\text{ ms}$	–	–	50	V
I_q	quiescent supply current	$V_P = 12.4\text{ V}$; note 2; $I_{\text{REG2}} = 0.1\text{ mA}$	–	500	600	μA
		$V_P = 14.4\text{ V}$; note 2; $I_{\text{REG2}} = 0.1\text{ mA}$	–	520	–	μA
Schmitt trigger power supply for regulator 1, regulator 3 and power switch						
V_{thr}	rising threshold voltage		4.0	4.5	5.0	V
V_{thf}	falling threshold voltage		3.5	4.0	4.5	V
V_{hys}	hysteresis voltage		–	0.5	–	V
Schmitt trigger for regulator 2						
V_{thr}	rising threshold voltage		6.0	6.5	7.1	V
V_{thf}	falling threshold voltage		1.7	1.9	2.2	V
V_{hys}	hysteresis voltage		–	4.6	–	V
Schmitt trigger for enable input (regulator 1, regulator 3 and power switch)						
V_{thr}	rising threshold voltage		1.7	2.2	2.7	V
V_{thf}	falling threshold voltage		1.5	2.0	2.5	V
V_{hys}	hysteresis voltage	$I_{\text{REG}} = I_{\text{SW}} = 1\text{ mA}$	0.1	0.2	0.5	V
I_{LI}	input leakage current	$V_{\text{EN}} = 5\text{ V}$	1	5	10	μA
Schmitt trigger for reset						
V_{thr}	rising threshold voltage of regulator 2	V_P rising; $I_{\text{REG1}} = 50\text{ mA}$; note 3	–	$V_{\text{REG2}} - 0.15$	$V_{\text{REG2}} - 0.075$	V
V_{thf}	falling threshold voltage of regulator 2	V_P rising; $I_{\text{REG1}} = 50\text{ mA}$; note 3	4.3	$V_{\text{REG2}} - 0.35$	–	V
V_{hys}	hysteresis voltage		0.1	0.2	0.3	V
Schmitt trigger for hold						
V_{thr}	rising threshold voltage of regulator 1	V_P rising; note 3	–	$V_{\text{REG1}} - 0.15$	$V_{\text{REG1}} - 0.075$	V
V_{thf}	falling threshold voltage of regulator 1	V_P rising; note 3	9.2	$V_{\text{REG1}} - 0.35$	–	V
V_{hys}	hysteresis voltage		0.1	0.2	0.3	V

Multiple voltage regulator with switch

TDA3608Q

SYMBOL	PARAMETER	CONDITIONS	MIN.	TYP.	MAX.	UNIT
Reset and hold buffer						
I_{sinkL}	LOW-level sink current	$V_{\text{RES/HOLD}} \leq 0.8 \text{ V}$	2	–	–	mA
I_{LO}	output leakage current	$V_{\text{P}} = 14.4 \text{ V}; V_{\text{RES/HOLD}} = 5 \text{ V}$	–	–	2	μA
t_{r}	rise time	note 4	–	7	50	μs
t_{f}	fall time	note 4	–	1	50	μs
Reset delay						
I_{ch}	charge current		2	4	8	μA
I_{dch}	discharge current		500	800	–	μA
V_{thr}	rising threshold voltage		2.5	3.0	3.5	V
t_{d}	delay time	$C = 47 \text{ nF};$ note 5	20	35	70	ms
Regulator 1 ($I_{\text{REG1}} = 5 \text{ mA}$ unless otherwise specified)						
$V_{\text{O(off)}}$	output voltage off		–	1	400	mV
V_{O}	output voltage	$1 \text{ mA} \leq I_{\text{REG1}} \leq 600 \text{ mA}$	8.15	8.5	8.85	V
		$11 \text{ V} \leq V_{\text{P}} \leq 18 \text{ V}$	8.15	8.5	8.85	V
ΔV	line regulation	$11 \text{ V} \leq V_{\text{P}} \leq 18 \text{ V}$	–	2	75	mV
ΔV_{L}	load regulation	$1 \text{ mA} \leq I_{\text{REG1}} \leq 600 \text{ mA}$	–	20	50	mV
I_{q}	quiescent current	$I_{\text{REG1}} = 600 \text{ mA}$	–	25	60	mA
SVRR	supply voltage ripple rejection	$f_{\text{i}} = 3 \text{ kHz}; V_{\text{i(p-p)}} = 2 \text{ V}$	60	70	–	dB
V_{d}	drop-out voltage	$I_{\text{REG1}} = 550 \text{ mA}; V_{\text{P}} = 8.5 \text{ V};$ note 6	–	0.4	0.7	V
I_{m}	current limit	$V_{\text{REG1}} > 7.5 \text{ V};$ note 7	0.65	1.2	–	A
I_{sc}	short-circuit current	$R_{\text{L}} \leq 0.5 \Omega;$ note 8	250	800	–	mA
Regulator 2 ($I_{\text{REG2}} = 5 \text{ mA}$ unless otherwise specified)						
V_{O}	output voltage	$0.5 \text{ mA} \leq I_{\text{REG2}} \leq 150 \text{ mA}$	4.75	5.0	5.25	V
		$I_{\text{REG2}} = 300 \text{ mA};$ note 9	4.75	5.0	5.25	V
		$7 \text{ V} \leq V_{\text{P}} \leq 18 \text{ V}$	4.75	5.0	5.25	V
		$18 \text{ V} \leq V_{\text{P}} \leq 50 \text{ V};$ $I_{\text{REG2}} \leq 150 \text{ mA}$	4.75	5.0	5.25	V
ΔV	line regulation	$6 \text{ V} \leq V_{\text{P}} \leq 18 \text{ V}$	–	2	50	mV
		$18 \text{ V} \leq V_{\text{P}} \leq 50 \text{ V}$	–	15	75	mV
ΔV_{L}	load regulation	$1 \text{ mA} \leq I_{\text{REG2}} \leq 150 \text{ mA}$	–	20	50	mV
		$1 \text{ mA} \leq I_{\text{REG2}} \leq 300 \text{ mA}$	–	–	100	mV
SVRR	supply voltage ripple rejection	$f_{\text{i}} = 3 \text{ kHz}; V_{\text{i(p-p)}} = 2 \text{ V}$	60	70	–	dB

Multiple voltage regulator with switch

TDA3608Q

SYMBOL	PARAMETER	CONDITIONS	MIN.	TYP.	MAX.	UNIT
V_d	drop-out voltage	$I_{REG2} = 100 \text{ mA}; V_P = 4.75 \text{ V}; \text{note 6}$	–	0.4	0.6	V
		$I_{REG2} = 200 \text{ mA}; V_P = 5.75 \text{ V}; \text{note 6}$	–	0.8	1.2	V
		$I_{REG2} = 100 \text{ mA}; V_{BU} = 4.75 \text{ V}; \text{note 10}$	–	0.2	0.5	V
		$I_{REG2} = 200 \text{ mA}; V_{BU} = 5.75 \text{ V}; \text{note 10}$	–	0.8	1.0	V
I_m	current limit	$V_{REG2} > 4.5 \text{ V}; \text{note 7}$	0.32	0.37	–	A
I_{sc}	short-circuit current	$R_L \leq 0.5 \Omega; \text{note 8}$	20	100	–	mA
Regulator 3 ($I_{REG3} = 5 \text{ mA}$ unless otherwise specified)						
$V_{O(off)}$	output voltage off		–	1	400	mV
V_O	output voltage	$1 \text{ mA} \leq I_{REG3} \leq 400 \text{ mA}$	4.75	5.0	5.25	V
		$7 \text{ V} \leq V_P \leq 18 \text{ V}$	4.75	5.0	5.25	V
ΔV	line regulation	$7 \text{ V} \leq V_P \leq 18 \text{ V}$	–	2	50	mV
ΔV_L	load regulation	$1 \text{ mA} \leq I_{REG3} \leq 400 \text{ mA}$	–	20	50	mV
I_q	quiescent current	$I_{REG3} = 400 \text{ mA}$	–	15	40	mA
SVRR	supply voltage ripple rejection	$f_i = 3 \text{ kHz}; V_{i(p-p)} = 2 \text{ V}$	60	70	–	dB
V_d	drop-out voltage	$I_{REG3} = 400 \text{ mA}; V_P = 5.75 \text{ V}; \text{note 6}$	–	1	1.5	V
I_m	current limit	$V_{REG3} > 4.5 \text{ V}; \text{note 7}$	0.45	0.70	–	A
I_{sc}	short-circuit current	$R_L \leq 0.5 \Omega; \text{note 8}$	100	400		mA
Power switch						
V_d	drop-out voltage	$I_{SW} = 1 \text{ A}; \text{note 11}$	–	0.45	0.7	V
		$I_{SW} = 1.8 \text{ A}; \text{note 11}$	–	1.0	1.8	V
I_{dc}	continuous current	$V_P = 16 \text{ V}, V_{SW} = 13.5 \text{ V}$	1.8	2.0	–	A
V_{cl}	clamping voltage	$V_P \geq 17 \text{ V}$	13.5	15.0	16.0	V
I_M	peak current	$V_P = 17 \text{ V}; \text{notes 12 and 13}$	3	–	–	A
V_{fb}	fly back voltage behaviour	$I_{SW} = -100 \text{ mA}$	–	$V_P + 3$	22	V
I_{sc}	short-circuit current	$V_P = 14.4 \text{ V}; V_{SW} < 1.2 \text{ V}; \text{note 13}$		0.8	–	A
Back-up switch						
I_{dc}	continuous current		0.3	0.35	–	A
V_{cl}	clamping voltage	$V_P \geq 16.7 \text{ V}$	–	–	16	V
I_r	reverse current	$V_P = 0; V_{BU} = 12.4 \text{ V}; \text{note 14}$	–	–	900	mA

Multiple voltage regulator with switch

TDA3608Q

Notes

1. Minimum operating voltage, only if V_P has exceeded 6.5 V.
2. The quiescent current is measured in the standby mode. So, the enable inputs of regulators 1, 3 and the switch are grounded and $R_{L(REG2)} = \infty$ (see Fig.6).
3. The voltage of the regulator sinks as a result of a V_P drop.
4. The rise and fall time is measured with a 10 k Ω pull-up resistor and a 50 pF load capacitor.
5. The delay time depends on the value of the capacitor: $t_d = \frac{C}{I_{ch}} \times V_{C(th)} = C \times (750 \times 10^3)$ (ms)
6. The drop-out voltage of regulators 1, 2 and 3 is measured between V_P and REGn.
7. At current limit, I_{REGmn} is held constant (see Fig.4 for behaviour of I_{REGmn}).
8. The foldback current protection limits the dissipated power at short-circuit (see Fig.4).
9. The peak current of 300 mA can only be applied for short periods ($t < 100$ ms).
10. The drop-out voltage measured between BU and REG2.
11. The drop-out voltage of the power switch is measured between V_P and SW.
12. The maximum output current of the power switch is limited to 1.8 A when the supply voltage exceeds 18 V.
13. At short-circuit, I_{sc} of the power switch is held constant to a lower value than the continuous current after a delay of at least 10 ms (see Fig.5).
14. The reverse current of the back-up switch is measured when flowing out of pin V_P with $V_P = 0$ V.

Multiple voltage regulator with switch

TDA3608Q

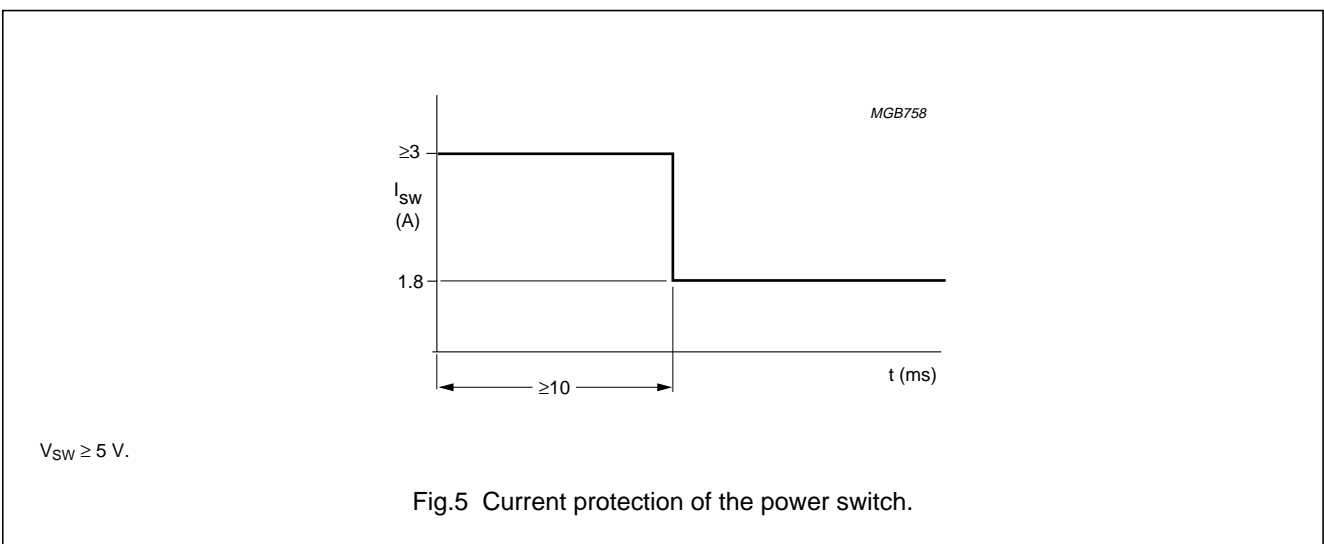
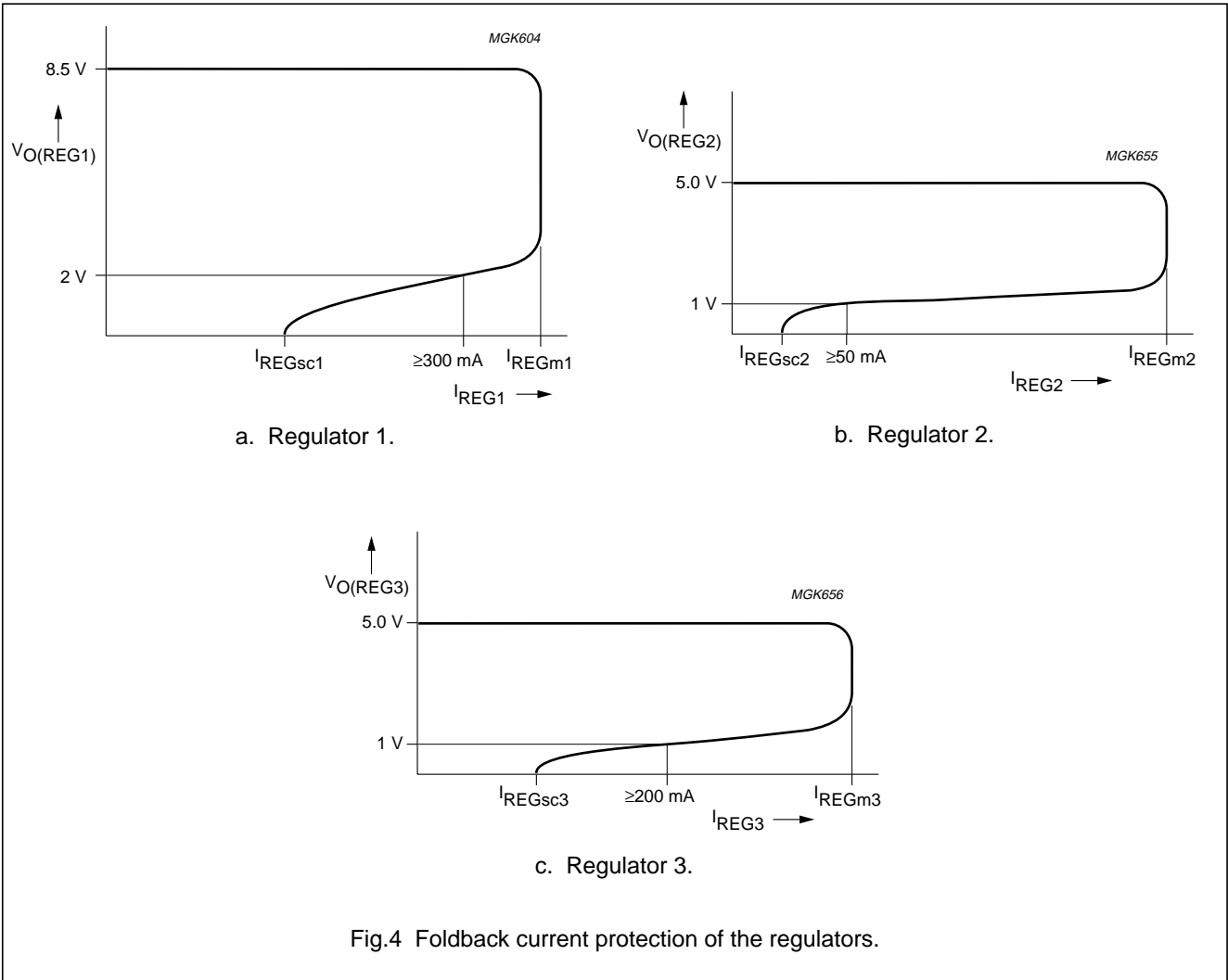

Multiple voltage regulator with switch

TDA3608Q

TEST AND APPLICATION INFORMATION

Test information

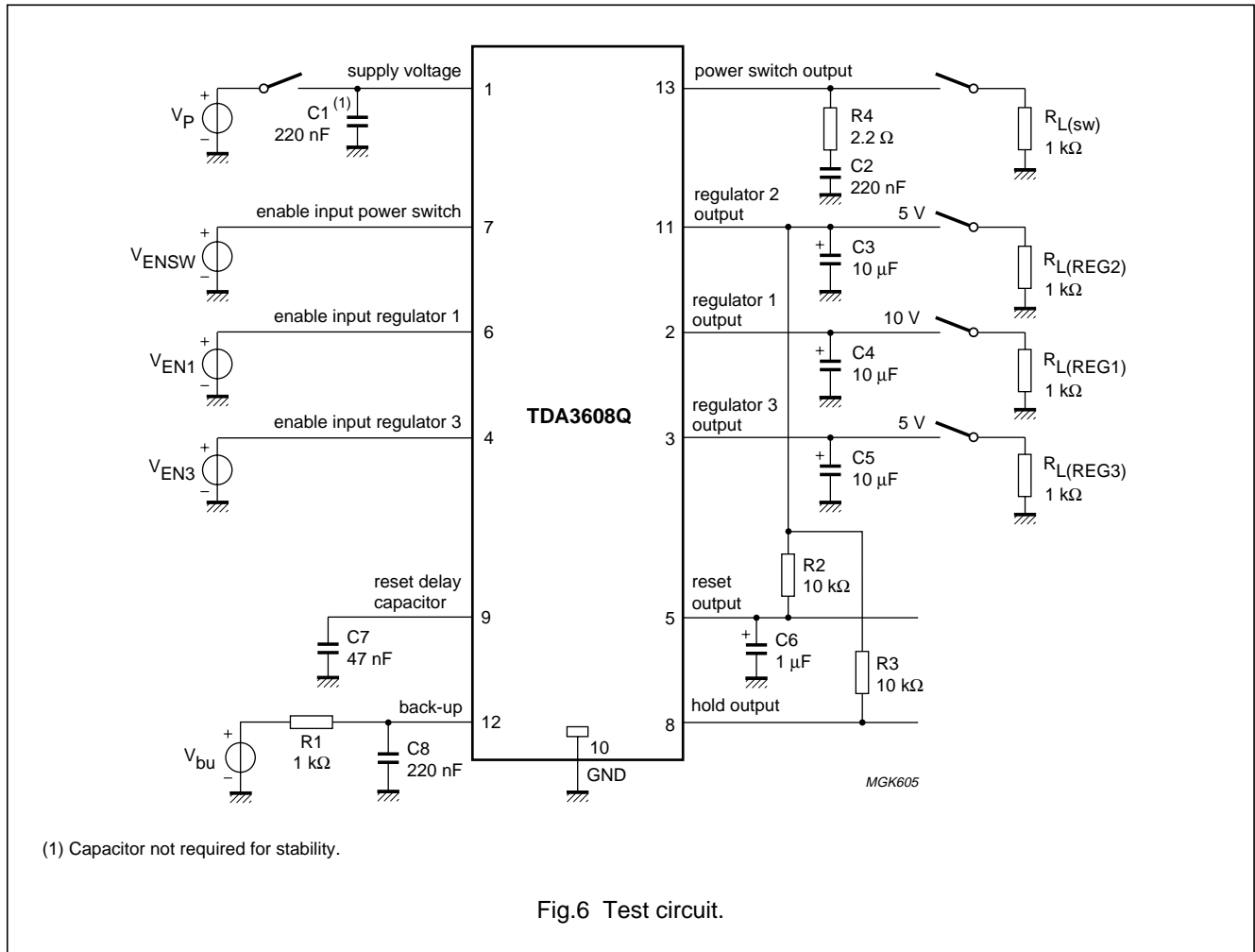

Application information

NOISE

The noise on the supply line depends on the value of the supply capacitor and is caused by a current noise (output noise of the regulators is translated into a current noise by means of the output capacitors). Table 1 shows the noise figure with the corresponding output capacitor for each regulator. The noise is minimal when a high frequency capacitor of 220 nF in parallel with an electrolytic capacitor of 100 μF is connected directly to pins V_P and GND.

Table 1 Noise figures

REGULATOR	NOISE FIGURE ⁽¹⁾		
	C _O = 10 μF	C _O = 47 μF	C _O = 100 μF
1	225 μV	150 μV	135 μV
2	225 μV	150 μV	135 μV
3	255 μV	200 μV	180 μV

Note

1. Measured at a bandwidth of 200 kHz.

Multiple voltage regulator with switch

TDA3608Q

STABILITY

The regulators are made stable with the external connected output capacitors. The output capacitors can be selected using the graphs of Figs 7 and 8.

When an electrolytic capacitor is used, the temperature behaviour of this output capacitor can cause oscillations at low temperature. The next two examples show how an output capacitor value is selected.

Example 1

The regulator 1 is made stable with an electrolytic output capacitor of 220 μF , Equivalent Series Resistance (ESR) = 0.15 Ω . At -30°C the capacitor value is

decreased to 73 μF and the ESR is increased to 1.1 Ω . The regulator will remain stable at -30°C (see Fig.7).

Example 2

The regulator 2 is made stable with a 10 μF electrolytic capacitor (ESR = 3 Ω). At -30°C the capacitor value is decreased to 3 μF and the ESR is increased to 23.1 Ω . The regulator will be instable at -30°C (see Fig.8).

Solution

Use a tantalum capacitor of 10 μF or a larger electrolytic capacitor. The use of tantalum capacitors is recommended to avoid problems with stability at low temperatures.

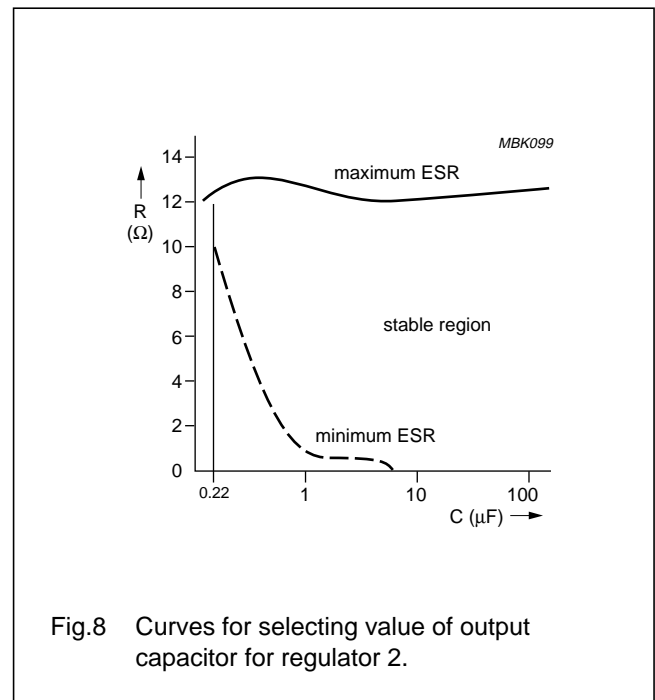
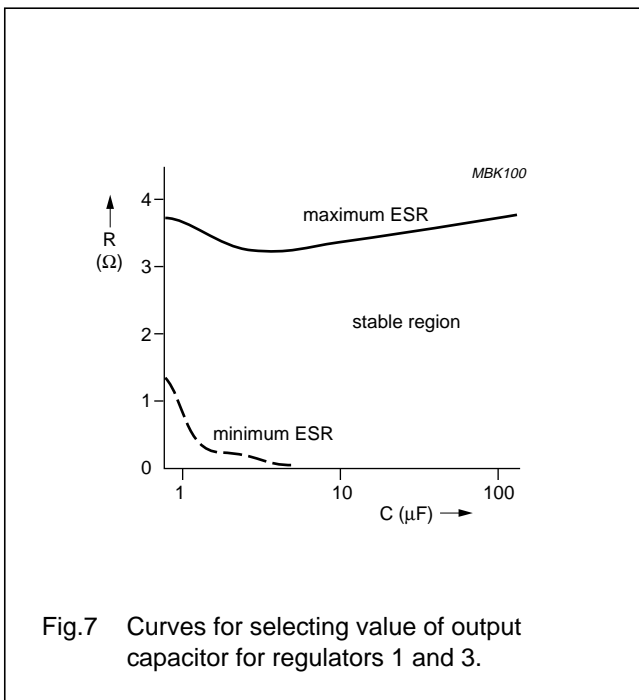

Multiple voltage regulator with switch

TDA3608Q

PACKAGE OUTLINE

DBS13P: plastic DIL-bent-SIL power package; 13 leads (lead length 12 mm)

SOT141-6

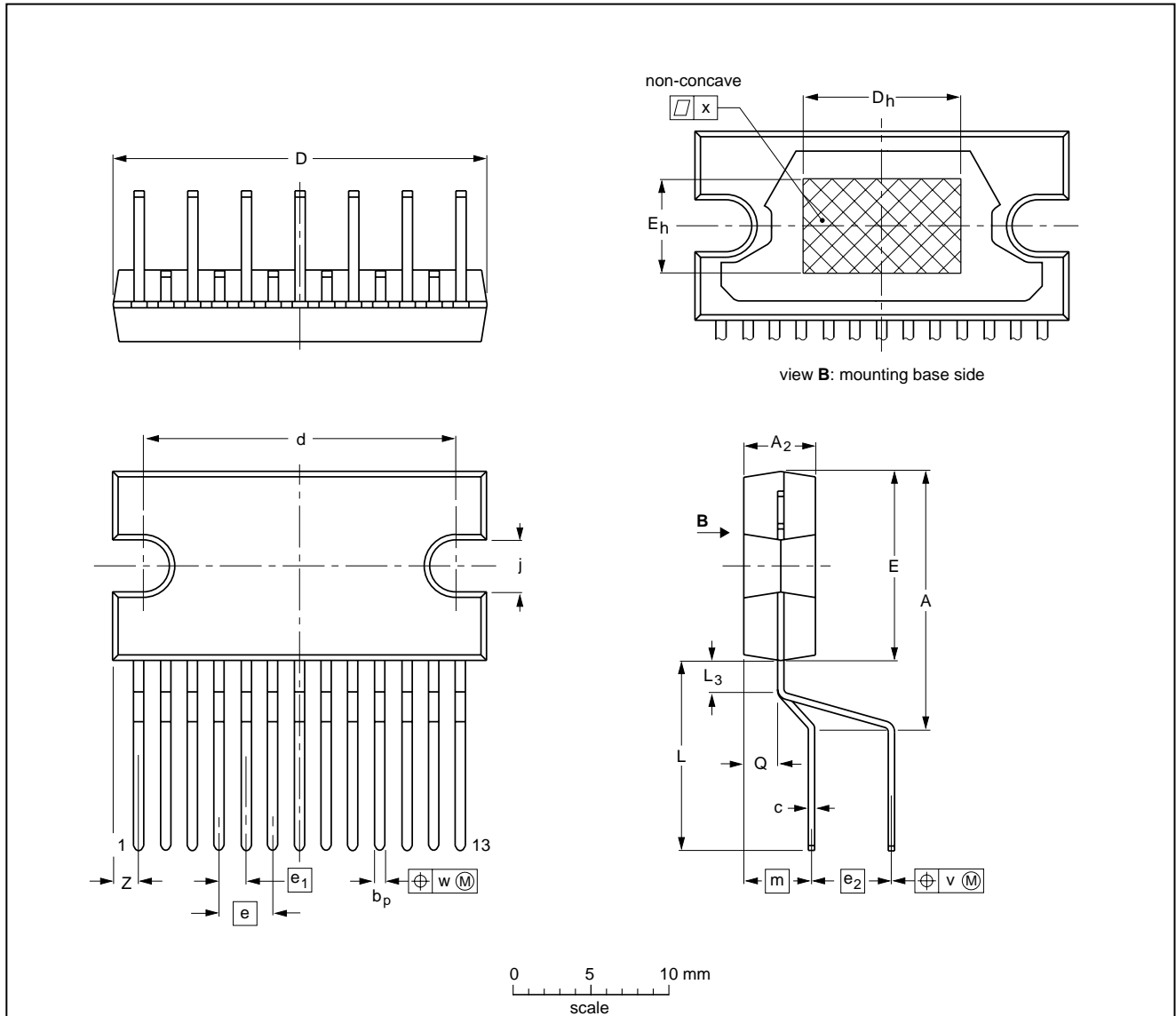

DIMENSIONS (mm are the original dimensions)

UNIT	A	A ₂	b _p	c	D ⁽¹⁾	d	D _h	E ⁽¹⁾	e	e ₁	e ₂	E _h	j	L	L ₃	m	Q	v	w	x	Z ⁽¹⁾
mm	17.0 15.5	4.6 4.2	0.75 0.60	0.48 0.38	24.0 23.6	20.0 19.6	10	12.2 11.8	3.4	1.7	5.08	6	3.4 3.1	12.4 11.0	2.4 1.6	4.3	2.1 1.8	0.8	0.25	0.03	2.00 1.45

Note

1. Plastic or metal protrusions of 0.25 mm maximum per side are not included.

OUTLINE VERSION	REFERENCES			EUROPEAN PROJECTION	ISSUE DATE
	IEC	JEDEC	EIAJ		
SOT141-6					92-11-17 95-03-11

Multiple voltage regulator with switch

TDA3608Q

SOLDERING

Introduction

There is no soldering method that is ideal for all IC packages. Wave soldering is often preferred when through-hole and surface mounted components are mixed on one printed-circuit board. However, wave soldering is not always suitable for surface mounted ICs, or for printed-circuits with high population densities. In these situations reflow soldering is often used.

This text gives a very brief insight to a complex technology. A more in-depth account of soldering ICs can be found in our "IC Package Databook" (order code 9398 652 90011).

Soldering by dipping or by wave

The maximum permissible temperature of the solder is 260 °C; solder at this temperature must not be in contact with the joint for more than 5 seconds. The total contact time of successive solder waves must not exceed 5 seconds.

The device may be mounted up to the seating plane, but the temperature of the plastic body must not exceed the specified maximum storage temperature ($T_{stg\ max}$). If the printed-circuit board has been pre-heated, forced cooling may be necessary immediately after soldering to keep the temperature within the permissible limit.

Repairing soldered joints

Apply a low voltage soldering iron (less than 24 V) to the lead(s) of the package, below the seating plane or not more than 2 mm above it. If the temperature of the soldering iron bit is less than 300 °C it may remain in contact for up to 10 seconds. If the bit temperature is between 300 and 400 °C, contact may be up to 5 seconds.

DEFINITIONS

Data sheet status	
Objective specification	This data sheet contains target or goal specifications for product development.
Preliminary specification	This data sheet contains preliminary data; supplementary data may be published later.
Product specification	This data sheet contains final product specifications.
Limiting values	
Limiting values given are in accordance with the Absolute Maximum Rating System (IEC 134). Stress above one or more of the limiting values may cause permanent damage to the device. These are stress ratings only and operation of the device at these or at any other conditions above those given in the Characteristics sections of the specification is not implied. Exposure to limiting values for extended periods may affect device reliability.	
Application information	
Where application information is given, it is advisory and does not form part of the specification.	

LIFE SUPPORT APPLICATIONS

These products are not designed for use in life support appliances, devices, or systems where malfunction of these products can reasonably be expected to result in personal injury. Philips customers using or selling these products for use in such applications do so at their own risk and agree to fully indemnify Philips for any damages resulting from such improper use or sale.

Multiple voltage regulator with switch

TDA3608Q

NOTES

Multiple voltage regulator with switch

TDA3608Q

NOTES

Multiple voltage regulator with switch

TDA3608Q

NOTES

Philips Semiconductors – a worldwide company

Argentina: see South America

Australia: 34 Waterloo Road, NORTH RYDE, NSW 2113,
Tel. +61 2 9805 4455, Fax. +61 2 9805 4466

Austria: Computerstr. 6, A-1101 WIEN, P.O. Box 213, Tel. +43 160 1010,
Fax. +43 160 101 1210

Belarus: Hotel Minsk Business Center, Bld. 3, r. 1211, Volodarski Str. 6,
220050 MINSK, Tel. +375 172 200 733, Fax. +375 172 200 773

Belgium: see The Netherlands

Brazil: see South America

Bulgaria: Philips Bulgaria Ltd., Energoproject, 15th floor,
51 James Bourchier Blvd., 1407 SOFIA,
Tel. +359 2 689 211, Fax. +359 2 689 102

Canada: PHILIPS SEMICONDUCTORS/COMPONENTS,
Tel. +1 800 234 7381

China/Hong Kong: 501 Hong Kong Industrial Technology Centre,
72 Tat Chee Avenue, Kowloon Tong, HONG KONG,
Tel. +852 2319 7888, Fax. +852 2319 7700

Colombia: see South America

Czech Republic: see Austria

Denmark: Prags Boulevard 80, PB 1919, DK-2300 COPENHAGEN S,
Tel. +45 32 88 2636, Fax. +45 31 57 0044

Finland: Sinikalliontie 3, FIN-02630 ESPOO,
Tel. +358 9 615800, Fax. +358 9 61580920

France: 4 Rue du Port-aux-Vins, BP317, 92156 SURESNES Cedex,
Tel. +33 1 40 99 6161, Fax. +33 1 40 99 6427

Germany: Hammerbrookstraße 69, D-20097 HAMBURG,
Tel. +49 40 23 53 60, Fax. +49 40 23 536 300

Greece: No. 15, 25th March Street, GR 17778 TAVROS/ATHENS,
Tel. +30 1 4894 339/239, Fax. +30 1 4814 240

Hungary: see Austria

India: Philips INDIA Ltd, Band Box Building, 2nd floor,
254-D, Dr. Annie Besant Road, Worli, MUMBAI 400 025,
Tel. +91 22 493 8541, Fax. +91 22 493 0966

Indonesia: see Singapore

Ireland: Newstead, Clonskeagh, DUBLIN 14,
Tel. +353 1 7640 000, Fax. +353 1 7640 200

Israel: RAPAC Electronics, 7 Kehilat Saloniki St, PO Box 18053,
TEL AVIV 61180, Tel. +972 3 645 0444, Fax. +972 3 649 1007

Italy: PHILIPS SEMICONDUCTORS, Piazza IV Novembre 3,
20124 MILANO, Tel. +39 2 6752 2531, Fax. +39 2 6752 2557

Japan: Philips Bldg 13-37, Kohnan 2-chome, Minato-ku, TOKYO 108,
Tel. +81 3 3740 5130, Fax. +81 3 3740 5077

Korea: Philips House, 260-199 Itaewon-dong, Yongsan-ku, SEOUL,
Tel. +82 2 709 1412, Fax. +82 2 709 1415

Malaysia: No. 76 Jalan Universiti, 46200 PETALING JAYA, SELANGOR,
Tel. +60 3 750 5214, Fax. +60 3 757 4880

Mexico: 5900 Gateway East, Suite 200, EL PASO, TEXAS 79905,
Tel. +9-5 800 234 7381

Middle East: see Italy

Netherlands: Postbus 90050, 5600 PB EINDHOVEN, Bldg. VB,
Tel. +31 40 27 82785, Fax. +31 40 27 88399

New Zealand: 2 Wagener Place, C.P.O. Box 1041, AUCKLAND,
Tel. +64 9 849 4160, Fax. +64 9 849 7811

Norway: Box 1, Manglerud 0612, OSLO,
Tel. +47 22 74 8000, Fax. +47 22 74 8341

Philippines: Philips Semiconductors Philippines Inc.,
106 Valero St. Salcedo Village, P.O. Box 2108 MCC, MAKATI,
Metro MANILA, Tel. +63 2 816 6380, Fax. +63 2 817 3474

Poland: Ul. Lukiska 10, PL 04-123 WARSZAWA,
Tel. +48 22 612 2831, Fax. +48 22 612 2327

Portugal: see Spain

Romania: see Italy

Russia: Philips Russia, Ul. Usatcheva 35A, 119048 MOSCOW,
Tel. +7 095 755 6918, Fax. +7 095 755 6919

Singapore: Lorong 1, Toa Payoh, SINGAPORE 1231,
Tel. +65 350 2538, Fax. +65 251 6500

Slovakia: see Austria

Slovenia: see Italy

South Africa: S.A. PHILIPS Pty Ltd., 195-215 Main Road Martindale,
2092 JOHANNESBURG, P.O. Box 7430 Johannesburg 2000,
Tel. +27 11 470 5911, Fax. +27 11 470 5494

South America: Rua do Rocio 220, 5th floor, Suite 51,
04552-903 São Paulo, SÃO PAULO - SP, Brazil,
Tel. +55 11 821 2333, Fax. +55 11 829 1849

Spain: Balmes 22, 08007 BARCELONA,
Tel. +34 3 301 6312, Fax. +34 3 301 4107

Sweden: Kottbygatan 7, Akalla, S-16485 STOCKHOLM,
Tel. +46 8 632 2000, Fax. +46 8 632 2745

Switzerland: Allmendstrasse 140, CH-8027 ZÜRICH,
Tel. +41 1 488 2686, Fax. +41 1 481 7730

Taiwan: Philips Semiconductors, 6F, No. 96, Chien Kuo N. Rd., Sec. 1,
TAIPEI, Taiwan Tel. +886 2 2134 2865, Fax. +886 2 2134 2874

Thailand: PHILIPS ELECTRONICS (THAILAND) Ltd.,
209/2 Sanpavuth-Bangna Road Prakanong, BANGKOK 10260,
Tel. +66 2 745 4090, Fax. +66 2 398 0793

Turkey: Talatpasa Cad. No. 5, 80640 GÜLTEPE/ISTANBUL,
Tel. +90 212 279 2770, Fax. +90 212 282 6707

Ukraine: PHILIPS UKRAINE, 4 Patrice Lumumba str., Building B, Floor 7,
252042 KIEV, Tel. +380 44 264 2776, Fax. +380 44 268 0461

United Kingdom: Philips Semiconductors Ltd., 276 Bath Road, Hayes,
MIDDLESEX UB3 5BX, Tel. +44 181 730 5000, Fax. +44 181 754 8421

United States: 811 East Arques Avenue, SUNNYVALE, CA 94088-3409,
Tel. +1 800 234 7381

Uruguay: see South America

Vietnam: see Singapore

Yugoslavia: PHILIPS, Trg N. Pasica 5/v, 11000 BEOGRAD,
Tel. +381 11 625 344, Fax. +381 11 635 777

For all other countries apply to: Philips Semiconductors, Marketing & Sales Communications,
Building BE-p, P.O. Box 218, 5600 MD EINDHOVEN, The Netherlands, Fax. +31 40 27 24825

Internet: <http://www.semiconductors.philips.com>

© Philips Electronics N.V. 1997

SCA55

All rights are reserved. Reproduction in whole or in part is prohibited without the prior written consent of the copyright owner.

The information presented in this document does not form part of any quotation or contract, is believed to be accurate and reliable and may be changed without notice. No liability will be accepted by the publisher for any consequence of its use. Publication thereof does not convey nor imply any license under patent- or other industrial or intellectual property rights.

Printed in The Netherlands

547027/1200/01/pp20

Date of release: 1997 Aug 14

Document order number: 9397 750 02238

Let's make things better.