

INTEGRATED CIRCUITS

DATA SHEET

TDA5051A Home automation modem

Product specification
Supersedes data of 1997 Sep 19
File under Integrated Circuits, IC11

1999 May 31

Home automation modem

TDA5051A

FEATURES

- Full digital carrier generation and shaping
- Modulation/demodulation frequency set by clock adjustment, from microcontroller or on-chip oscillator
- High clock rate of 6-bit A/D (Digital to Analog) converter for rejection of aliasing components
- Fully integrated output power stage with overload protection
- Automatic Gain Control (AGC) at receiver input
- 8-bit A/D (Analog to Analog) converter and narrow digital filtering
- Digital demodulation delivering baseband data
- Easy compliance with EN50065-1 with simple coupling network
- Few external components for low cost applications
- SO16 plastic package.

APPLICATIONS

- Home appliance control (air conditioning, shutters, lighting, alarms and so on)
- Energy/heating control
- Amplitude Shift Keying (ASK) data transmission using the home power network.

GENERAL DESCRIPTION

The TDA5051A is a modem IC, specifically dedicated to ASK transmission by means of the home power supply network, at 600 or 1200 baud data rate. It operates from a single 5 V supply.

QUICK REFERENCE DATA

SYMBOL	PARAMETER	CONDITIONS	MIN.	TYP.	MAX.	UNIT
V_{DD}	supply voltage		4.75	5.0	5.25	V
$I_{DD(tot)}$	total supply current	$f_{osc} = 8.48 \text{ MHz}$				
	reception mode		–	28	38	mA
	transmission mode ($\overline{DATA}_{IN} = 0$)	$Z_L = 30 \Omega$	–	47	68	mA
	power-down mode		–	19	25	mA
f_{cr}	carrier frequency	note 1	95	132.5	148.5	kHz
f_{osc}	oscillator frequency		6.08	8.48	9.504	MHz
$V_{o(rms)}$	output carrier signal on CISPR16 load (RMS value)		120	–	122	dB μ V
$V_{i(rms)}$	input signal (RMS value)	note 2	82	–	122	dB μ V
THD	total harmonic distortion on CISPR16 load with coupling network		–	–55	–	dB
Z_L	load impedance		1	30	–	Ω
BR	baud rate		–	600	1200	bits/s
T_{amb}	ambient temperature		0	–	70	$^{\circ}\text{C}$

Notes

1. Frequency range corresponding to the EN50065-1 band. However, the modem can operate at any lower oscillator frequency.
2. The minimum value can be improved by using an external amplifier, see application diagrams Figs 22 and 23.

Home automation modem

TDA5051A

ORDERING INFORMATION

TYPE NUMBER	PACKAGE		
	NAME	DESCRIPTION	VERSION
TDA5051AT	SO16	plastic small outline package; 16 leads; body width 7.5 mm	SOT162-1

BLOCK DIAGRAM

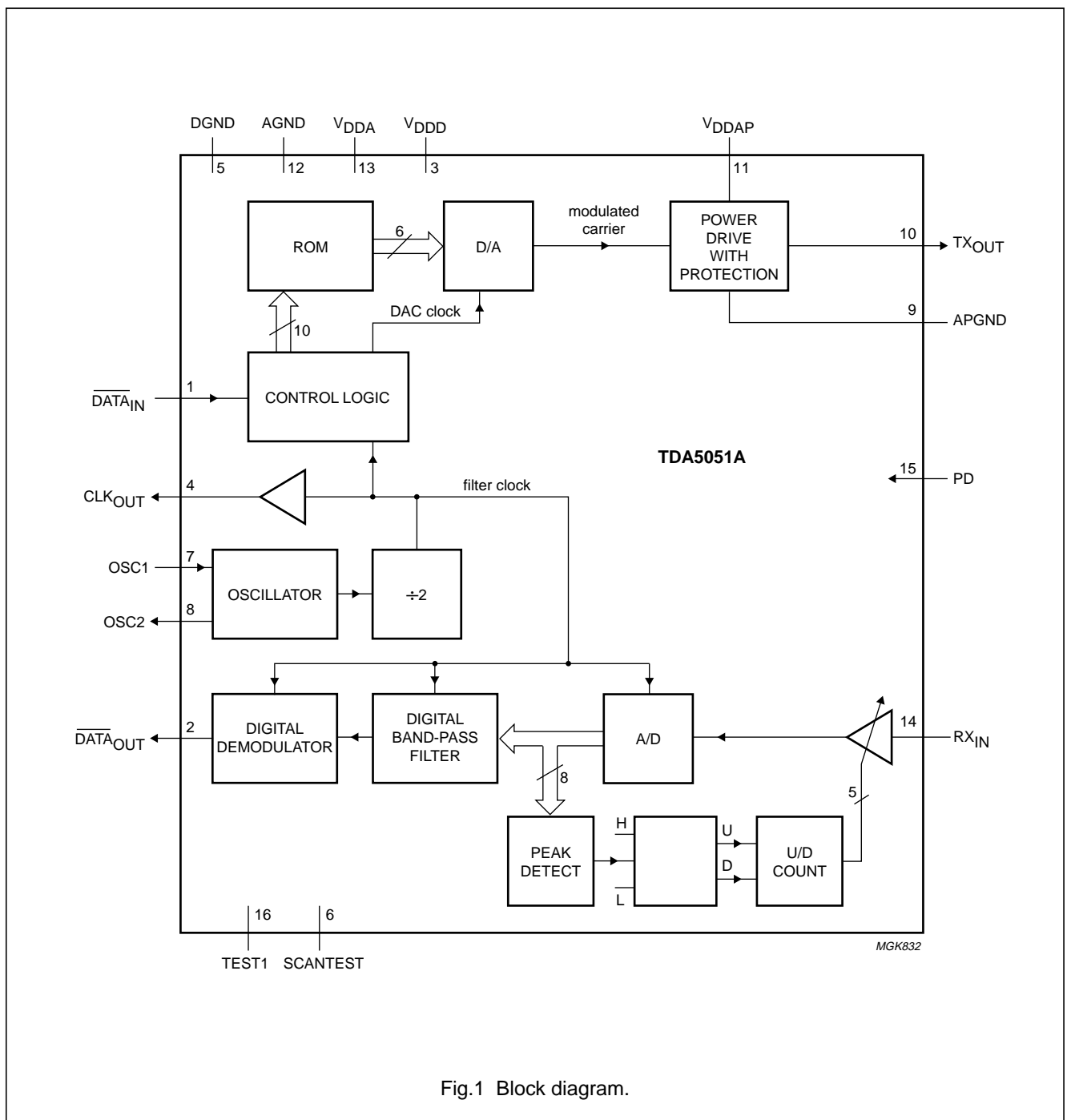

Fig.1 Block diagram.

Home automation modem

TDA5051A

PINNING

SYMBOL	PIN	DESCRIPTION
$\overline{\text{DATA}}_{\text{IN}}$	1	digital data input (active LOW)
$\overline{\text{DATA}}_{\text{OUT}}$	2	digital data output (active LOW)
V_{DDD}	3	digital supply voltage
CLK_{OUT}	4	clock output
DGND	5	digital ground
SCANTEST	6	test input (LOW in application)
OSC1	7	oscillator input
OSC2	8	oscillator output
APGND	9	analog ground for power amplifier
TX_{OUT}	10	analog signal output
V_{DDAP}	11	analog supply voltage for power amplifier
AGND	12	analog ground
V_{DDA}	13	analog supply voltage
RX_{IN}	14	analog signal input
PD	15	power-down input (active HIGH)
TEST1	16	test input (HIGH in application)

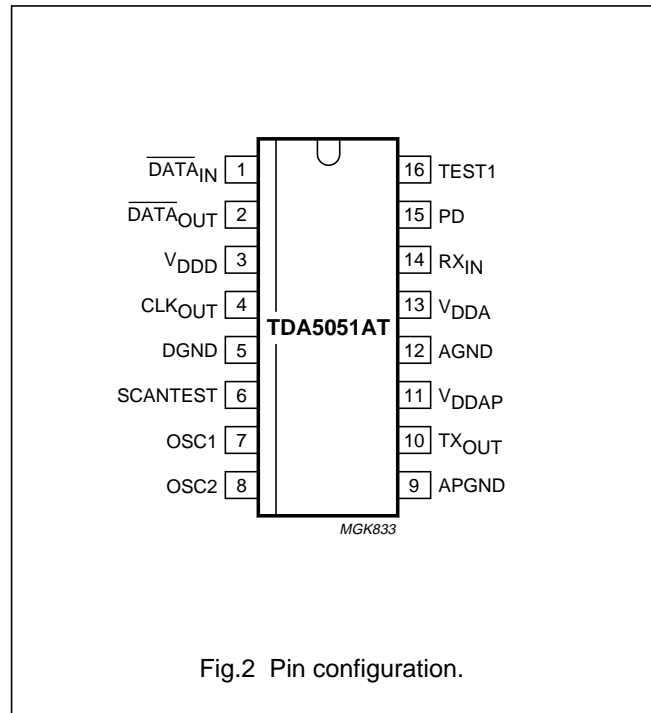

Fig.2 Pin configuration.

FUNCTIONAL DESCRIPTION

Both transmission and reception stages are controlled either by the master clock of the microcontroller or by the on-chip reference oscillator connected to a crystal. This ensures the accuracy of the transmission carrier and the exact trimming of the digital filter, thus making the performance totally independent of application disturbances such as component spread, temperature, supply drift and so on.

The interface with the power network is made by means of an LC network (see Fig.18). The device includes a power output stage that feeds a 120 dB μ V (RMS) signal on a typical 30 Ω load.

To reduce power consumption, the IC is disabled by a power-down input (pin PD): in this mode, the on-chip oscillator remains active and the clock continues to be supplied at pin CLK_{OUT} . For low-power operation in reception mode, this pin can be dynamically controlled by the microcontroller, see Section "Power-down mode".

When the circuit is connected to an external clock generator (see Fig.6), the clock signal must be applied at pin OSC1 (pin 7); OSC2 (pin 8) must be left open-circuit. Fig.7 shows the use of the on-chip clock circuit.

All logic inputs and outputs are compatible with TTL/CMOS levels, providing an easy connection to a standard microcontroller I/O port.

The digital part of the IC is fully scan-testable. Two digital inputs, SCANTEST and TEST1, are used for production test: these pins must be left open-circuit in functional mode (correct levels are internally defined by pull-up or pull-down resistors).

Transmission mode

To provide strict stability with respect to environmental conditions, the carrier frequency is generated by scanning the ROM memory under the control of the microcontroller clock or the reference frequency provided by the on-chip oscillator. High frequency clocking rejects the aliasing components to such an extent that they are filtered by the coupling LC network and do not cause any significant disturbance. The data modulation is applied through pin $\overline{\text{DATA}}_{\text{IN}}$ and smoothly applied by specific digital circuits to the carrier (shaping). Harmonic components are limited in this process, thus avoiding unacceptable disturbance of the transmission channel (according to CISPR16 and EN50065-1 recommendations). A -55 dB Total Harmonic Distortion (TDH) is reached when the typical LC coupling network (or an equivalent filter) is used.

Home automation modem

TDA5051A

The DAC and the power stage are set in order to provide a maximum signal level of 122 dB μ V (RMS) at the output.

The output of the power stage (TX_{OUT}) must **always** be connected to a decoupling capacitor, because of a DC level of 0.5V_{DD} at this pin, which is present even when the device is not transmitting. This pin must also be **protected against overvoltage and negative transient signals**. The DC level of TX_{OUT} can be used to bias a unipolar transient suppressor, as shown in the application diagram; see Fig.18.

Direct connection to the mains is done through an LC network for low-cost applications. However, a HF signal transformer could be used when power-line insulation has to be performed.

CAUTION

In transmission mode, the receiving part of the circuit is **not disabled** and the detection of the transmitted signal is normally performed. In this mode, the gain chosen before the beginning of the transmission is stored, and the **AGC is internally set to -6 dB** as long as DATA_{IN} is LOW. Then, the old gain setting is **automatically restored**.

Reception mode

The input signal received by the modem is applied to a wide range input amplifier with AGC (-6 to +30 dB). This is basically for noise performance improvement and signal level adjustment, which ensures a maximum sensitivity of the ADC. An 8-bit conversion is then performed, followed by digital band-pass filtering, to meet the CISPR normalization and to comply with some additional limitations met in current applications.

LIMITING VALUES

In accordance with the Absolute Maximum Rating System (IEC 134).

SYMBOL	PARAMETER	MIN.	MAX.	UNIT
V _{DD}	supply voltage	4.5	5.5	V
f _{osc}	oscillator frequency	-	12	MHz
T _{stg}	storage temperature	-50	+150	°C
T _{amb}	ambient temperature	-10	+80	°C
T _j	junction temperature	-	125	°C

HANDLING

Inputs and outputs are protected against electrostatic discharge in normal handling. However, to be totally safe, it is desirable to take normal precautions appropriate to handling MOS devices.

After digital demodulation, the baseband data signal is made available after pulse shaping.

The signal pin (RX_{IN}) is a high-impedance input which has to be protected and DC decoupled for the same reasons as with pin TX_{OUT}. The high sensitivity (82 dB μ V) of this input requires an efficient 50 Hz rejection filter (realized by the LC coupling network), which also acts as an anti-aliasing filter for the internal digital processing; see Fig.18.

Data format

TRANSMISSION MODE

The data input ($\overline{\text{DATA}}_{\text{IN}}$) is active LOW: this means that a burst is generated on the line (pin TX_{OUT}) when DATA_{IN} pin is LOW.

Pin TX_{OUT} is in a high-impedance state as long as the device is not transmitting. Successive logic 1s are treated in a Non-Return-to-Zero (NRZ) mode, see pulse shapes in Figs 8 and 9.

RECEPTION MODE

The data output (pin $\overline{\text{DATA}}_{\text{OUT}}$) is active LOW; this means that the data output is LOW when a burst is received. Pin $\overline{\text{DATA}}_{\text{OUT}}$ remains LOW as long as a burst is received.

Power-down mode

Power-down input (pin PD) is active HIGH; this means that the power consumption is minimum when pin PD is HIGH. Now, all functions are disabled, except clock generation.

Home automation modem

TDA5051A

CHARACTERISTICS

$V_{DD} = V_{DDA} = 5\text{ V} \pm 5\%$; $T_{\text{amb}} = 0\text{ to }70\text{ }^{\circ}\text{C}$; V_{DD} connected to V_{DDA} ; DGND connected to AGND.

SYMBOL	PARAMETER	CONDITIONS	MIN.	TYP.	MAX.	UNIT
Supply						
V_{DD}	supply voltage		4.75	5	5.25	V
$I_{DD(RX/TX)(\text{tot})}$	total analog + digital supply current	$V_{DD} = 5\text{ V} \pm 5\%$ TX or RX mode	–	28	38	mA
$I_{DD(PD)(\text{tot})}$	total analog + digital supply current;	$V_{DD} = 5\text{ V} \pm 5\%$; PD = HIGH Power-down mode	–	19	25	mA
$I_{DD(PAMP)}$	power amplifier supply current	$V_{DD} = 5\text{ V} \pm 5\%$; $Z_L = 30\ \Omega$; $\overline{\text{DATA}}_{\text{IN}} = \text{LOW}$ in transmission mode	–	19	30	mA
$I_{DD(PAMP)(\text{max})}$	maximum power amplifier supply current	$V_{DD} = 5\text{ V} \pm 5\%$; $Z_L = 1\ \Omega$; $\overline{\text{DATA}}_{\text{IN}} = \text{LOW}$ in transmission mode	–	76	–	mA
$\overline{\text{DATA}}_{\text{IN}}$ and PD inputs: $\overline{\text{DATA}}_{\text{OUT}}$ and CLK_{OUT} outputs						
V_{IH}	HIGH-level input voltage		$0.2V_{DD} + 0.9$	–	$V_{DD} + 0.5$	V
V_{IL}	LOW-level input voltage		–0.5	–	$0.2V_{DD} - 0.1$	V
V_{OH}	HIGH-level output voltage	$I_{\text{OH}} = -1.6\text{ mA}$	2.4	–	–	V
V_{OL}	LOW-level output voltage	$I_{\text{OL}} = 1.6\text{ mA}$	–	–	0.45	V
OSC1 input and OSC2 output (OSC2 only used for driving external quartz crystal; must be left open-circuit when using an external clock generator)						
V_{IH}	HIGH-level input voltage		$0.7V_{DD}$	–	$V_{DD} + 0.5$	V
V_{IL}	LOW-level input voltage		–0.5	–	$0.2V_{DD} - 0.1$	V
V_{OH}	HIGH-level output voltage	$I_{\text{OH}} = -1.6\text{ mA}$	2.4	–	–	V
V_{OL}	LOW-level output voltage	$I_{\text{OL}} = 1.6\text{ mA}$	–	–	0.45	V
Clock						
f_{osc}	oscillator frequency		6.080	–	9.504	MHz
$\frac{f_{\text{osc}}}{f_{\text{cr}}}$	ratio between oscillator and carrier frequency		–	64	–	
$\frac{f_{\text{osc}}}{f_{\text{CLKOUT}}}$	ratio between oscillator and clock output frequency		–	2	–	
Transmission mode						
f_{cr}	carrier frequency	$f_{\text{osc}} = 8.48\text{ MHz}$	–	132.5	–	kHz
t_{su}	set-up time of the shaped burst	$f_{\text{osc}} = 8.48\text{ MHz}$; see Fig.8	–	170	–	μs
t_{h}	hold time of the shaped burst	$f_{\text{osc}} = 8.48\text{ MHz}$; see Fig.8	–	170	–	μs

Home automation modem

TDA5051A

SYMBOL	PARAMETER	CONDITIONS	MIN.	TYP.	MAX.	UNIT
$t_{W(DI)(min)}$	minimum pulse width of $DATA_{IN}$ signal	$f_{osc} = 8.48$ MHz; see Fig.8	–	190	–	μ s
$V_{o(rms)}$	output carrier signal (RMS value)	$Z_L =$ CISPR16; $DATA_{IN} =$ LOW	120	–	122	$dB\mu$ V
$I_{o(max)}$	power amplifier maximum output current (peak value)	$Z_L = 1 \Omega$; $DATA_{IN} =$ LOW	–	160	–	mA
Z_o	output impedance of the power amplifier		–	5	–	Ω
V_o	output DC level at pin TX_{OUT}		–	2.5	–	V
THD	total harmonic distortion on CISPR16 load with the coupling network (measured on the first ten harmonics)	$V_{o(rms)} = 121$ $dB\mu$ V on CISPR16 load; $f_{osc} = 8.48$ MHz; $DATA_{IN} =$ LOW (no modulation); see Figs 3 and 16	–	–55	–	dB
B_{-20dB}	bandwidth of the shaped output signal (at –20 dB) on CISPR16 load with the coupling network	$V_{o(rms)} = 121$ $dB\mu$ V on CISPR16 load; $f_{osc} = 8.48$ MHz; $DATA_{IN} = 300$ Hz; duty factor = 50%; see Fig.4	–	3000	–	Hz
Reception mode						
$V_{i(rms)}$	analog input signal (RMS value)		82	–	122	$dB\mu$ V
V_I	DC level at pin RX_{IN}		–	2.5	–	V
Z_i	RX_{IN} input impedance		–	50	–	$k\Omega$
R_{AGC}	AGC range		–	36	–	dB
$t_{c(AGC)}$	AGC time constant	$f_{osc} = 8.48$ MHz; see Fig.5	–	296	–	μ s
$t_{d(dem)(su)}$	demodulation delay set-up time	$f_{osc} = 8.48$ MHz; see Fig.15	–	350	400	μ s
$t_{d(dem)(h)}$	demodulation delay hold time	$f_{osc} = 8.48$ MHz; see Fig.15	–	420	470	μ s
B_{det}	detection bandwidth	$f_{osc} = 8.48$ MHz	–	3	–	kHz
BER	bit error rate	$f_{osc} = 8.48$ MHz; 600 baud; S/N = 35 dB; signal 76 $dB\mu$ V; see Fig.17	–	1	–	1×10^{-4}

Home automation modem

TDA5051A

SYMBOL	PARAMETER	CONDITIONS	MIN.	TYP.	MAX.	UNIT
Power-up timing						
$t_{d(pu)(TX)}$	delay between power-up and $DATA_{IN}$ in transmission mode	XTAL = 8.48 MHz; C1 = C2 = 27 pF; $R_p = 2.2 M\Omega$; see Fig.10	–	1	–	μs
$t_{d(pu)(RX)}$	delay between power-up and $DATA_{OUT}$ in reception mode	XTAL = 8.48 MHz; C1 = C2 = 27 pF; $R_p = 2.2 M\Omega$; $f_{RXIN} = 132.5 kHz$; 120 dB μV sine wave; see Fig.11	–	1	–	μs
Power-down timing						
$t_{d(pd)(TX)}$	delay between PD = 0 and $DATA_{IN}$ in transmission mode	$f_{osc} = 8.48 MHz$; see Fig.12	–	10	–	μs
$t_{d(pd)(RX)}$	delay between PD = 0 and $DATA_{OUT}$ in reception mode	$f_{osc} = 8.48 MHz$; $f_{RXIN} = 132.5 kHz$; 120 dB μV sine wave; see Fig.13	–	500	–	μs
$t_{active(min)}$	minimum active time with T = 10 ms power-down period in reception mode	$f_{osc} = 8.48 MHz$; $f_{RXIN} = 132.5 kHz$; 120 dB μV sine wave; see Fig.14	–	1	–	μs

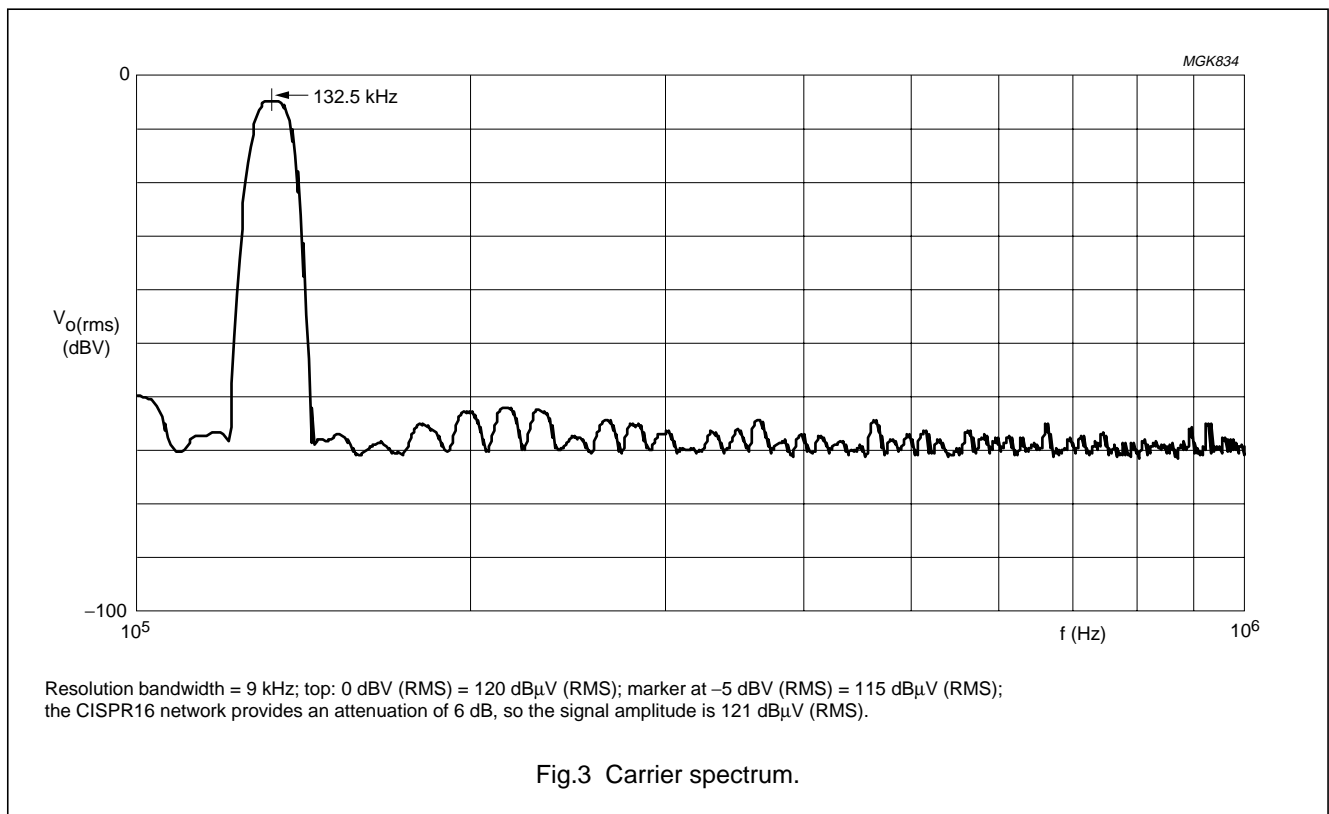

Home automation modem

TDA5051A

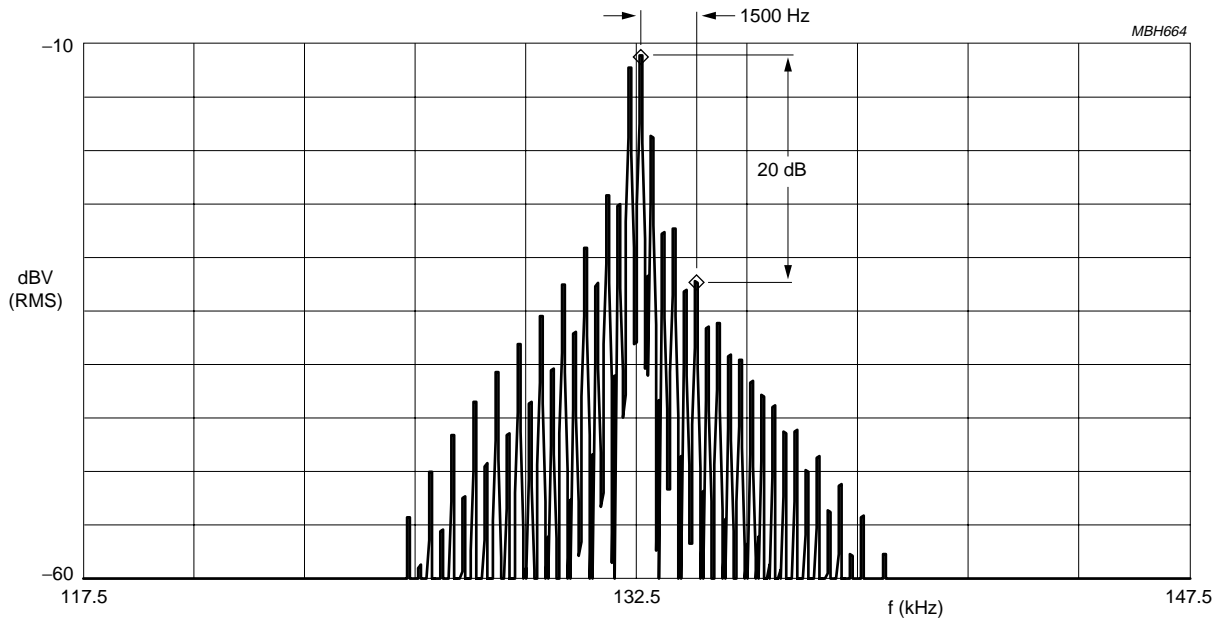

Resolution bandwidth = 100 Hz; $B_{-20dB} = 3000 \text{ Hz} (2 \times 1500 \text{ Hz})$.

Fig.4 Shaped signal spectrum.

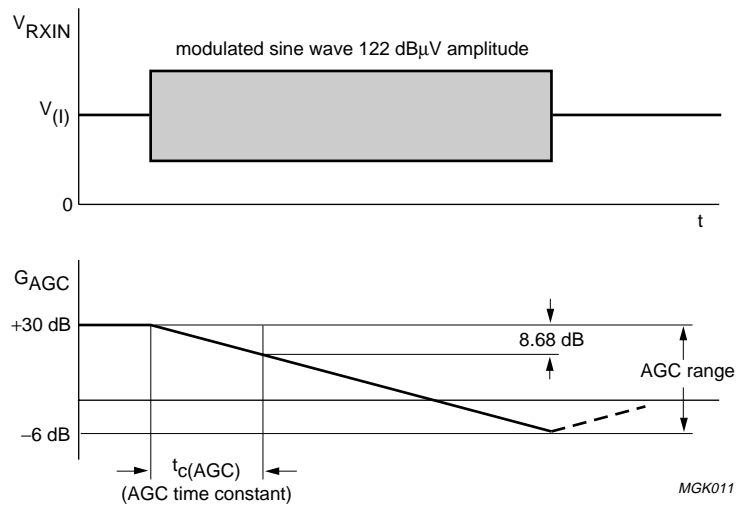

Fig.5 AGC time constant definition (not to scale).

Home automation modem

TDA5051A

TIMING

Configuration for clock

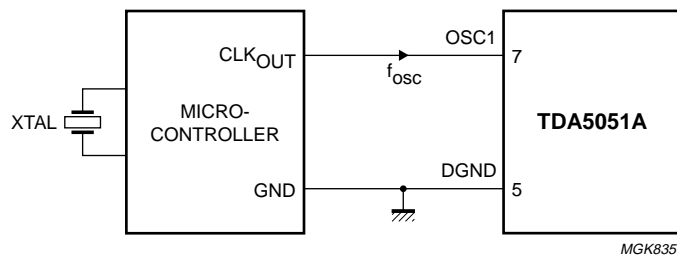

For parameter description, see Table 1.

Fig.6 External clock.

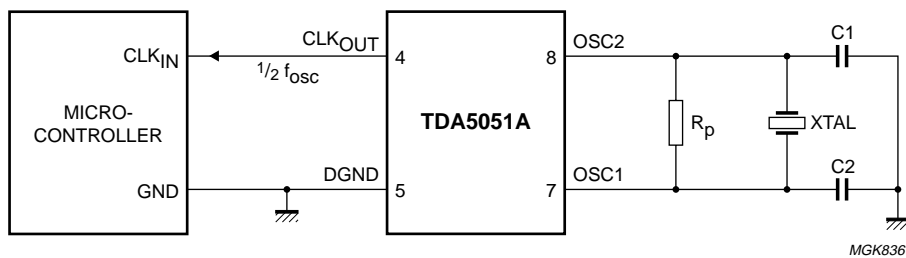

For parameter description, see Table 1.

Fig.7 Typical configuration for on-chip clock circuit.

Home automation modem

TDA5051A

Table 1 Clock oscillator parameters

OSCILLATOR FREQUENCY f_{osc}	CARRIER FREQUENCY f_{cr}	CLOCK OUTPUT FREQUENCY $\frac{1}{2}f_{osc}$	EXTERNAL COMPONENTS
6.080 to 9.504 MHz	95 to 148.5 kHz	3.040 to 4.752 MHz	C1 = C2 = 27 to 47 pF; R _p = 2.2 to 4.7 MΩ; XTAL = standard quartz crystal

Table 2 Calculation of parameters depending on the clock frequency

SYMBOL	PARAMETER	CONDITIONS	UNIT
f_{osc}	oscillator frequency	with on-chip oscillator: frequency of the crystal quartz; with external clock: frequency of the signal applied at OSC1	Hz
f_{CLKOUT}	clock output frequency	$\frac{1}{2}f_{osc}$	Hz
f_{cr}	carrier frequency/digital filter tuning frequency	$\frac{1}{64}f_{osc}$	Hz
t_{su}	set-up time of the shaped burst	$\frac{23}{f_{cr}}$ or $\frac{1472}{f_{osc}}$	s
t_h	hold time of the shaped burst	$\frac{23}{f_{cr}}$ or $\frac{1472}{f_{osc}}$	s
$t_{W(DI)(min)}$	minimum pulse width of \overline{DATA}_{IN} signal	$t_{su} + \frac{1}{f_{cr}}$	s
$t_{W(burst)(min)}$	minimum burst time of $V_{O(DC)}$ signal	$t_{W(DI)(min)} + t_h$	s
$t_{c(AGC)}$	AGC time constant	$\frac{2514}{f_{osc}}$	s
$t_{su(demod)}$	demodulation set-up time	$\frac{3200}{f_{osc}}$ (\approx max.)	s
$t_h(demod)$	demodulation hold time	$\frac{3800}{f_{osc}}$ (\approx max.)	s

Home automation modem

TDA5051A

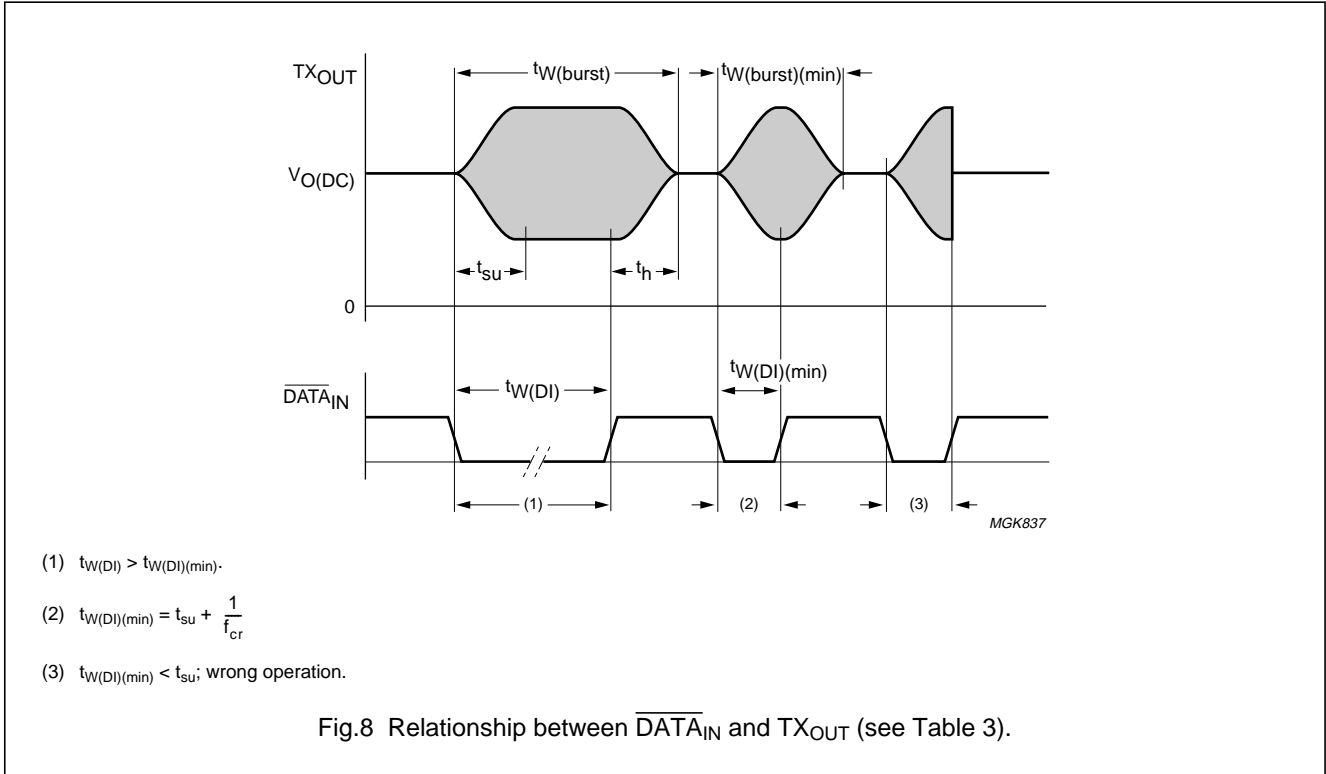
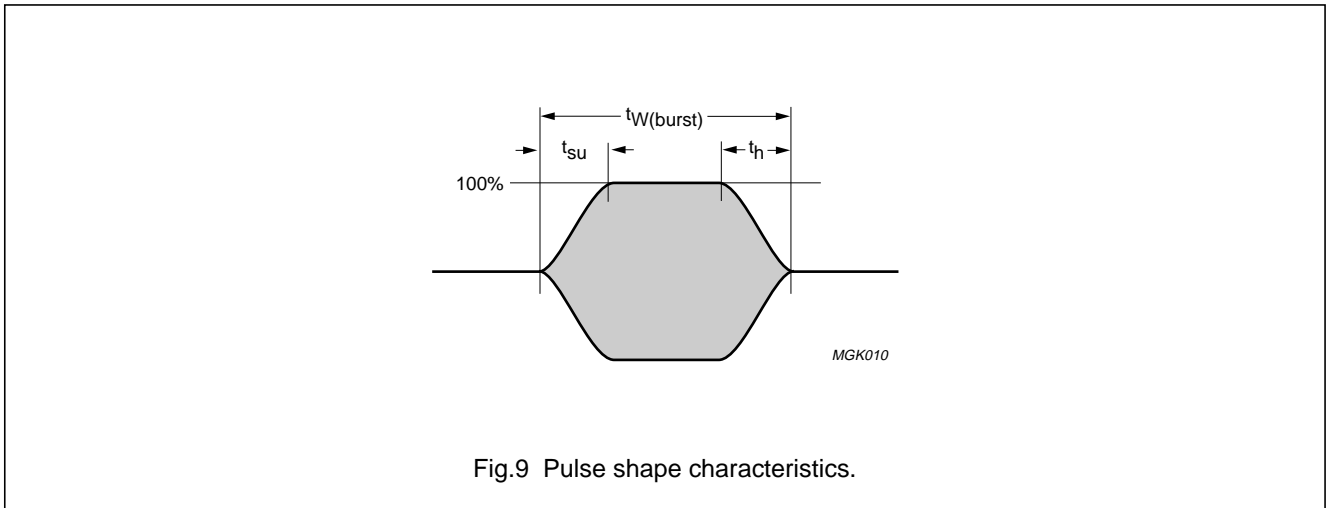

Table 3 Relationship between \overline{DATA}_{IN} and TX_{OUT}

PD	\overline{DATA}_{IN}	TX_{OUT}
1	X ⁽¹⁾	high-impedance
0	1	high-impedance (after t_h)
0	0	active with DC offset

Note

1. X = don't care.



Home automation modem

TDA5051A

Timing diagrams

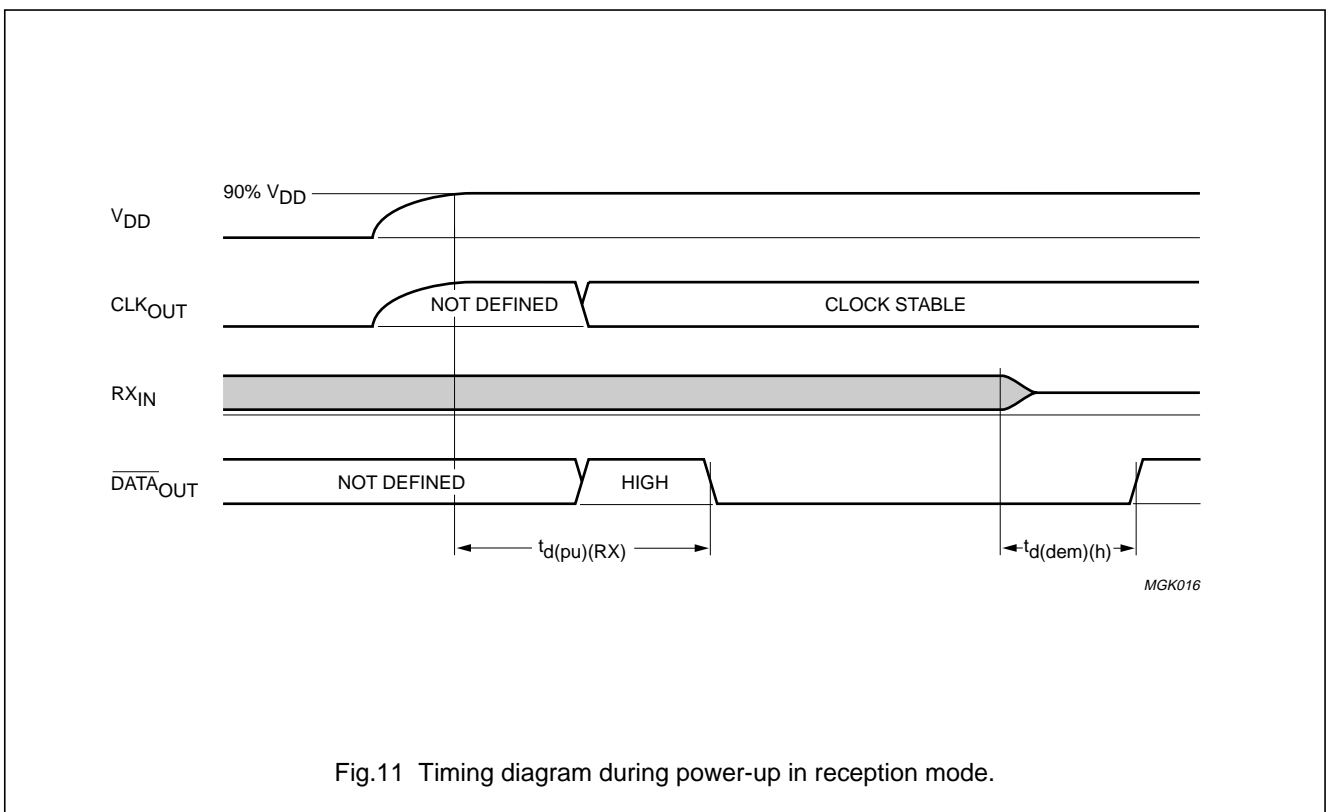
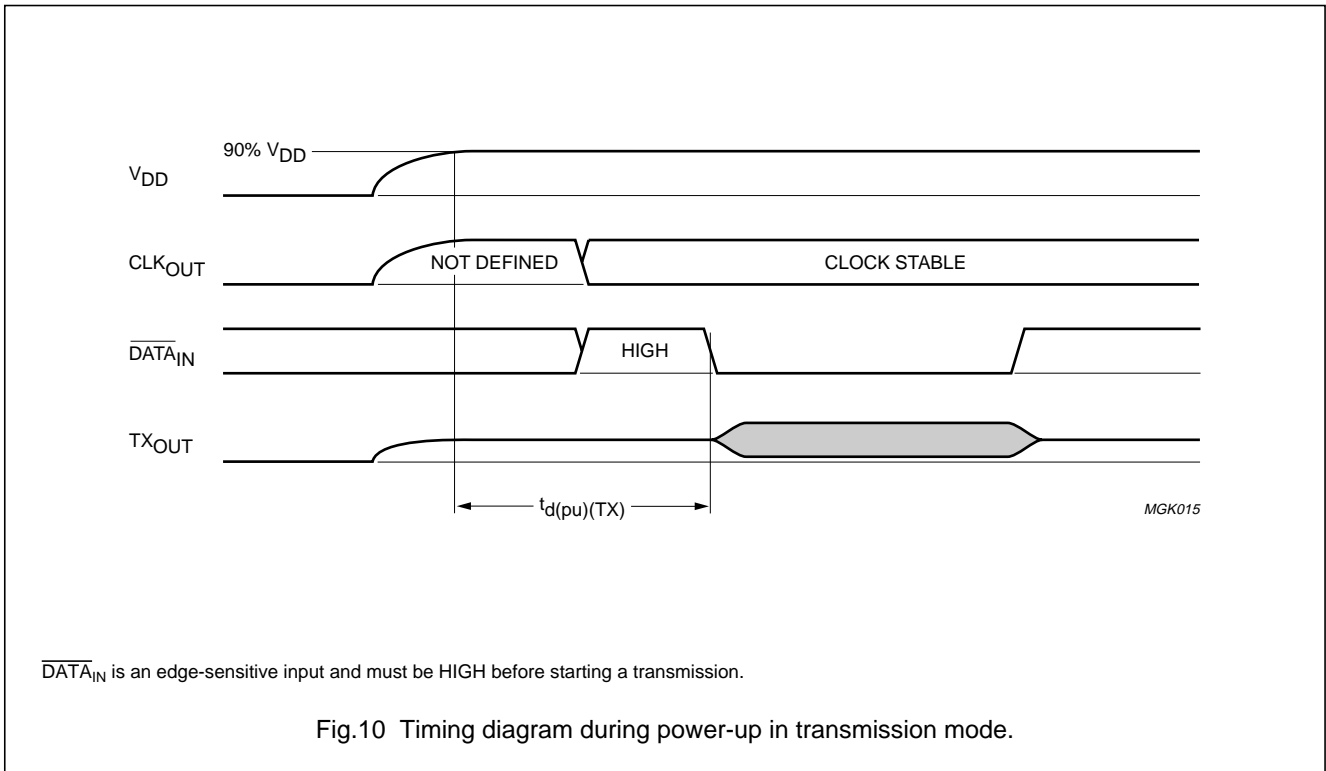

Home automation modem

TDA5051A

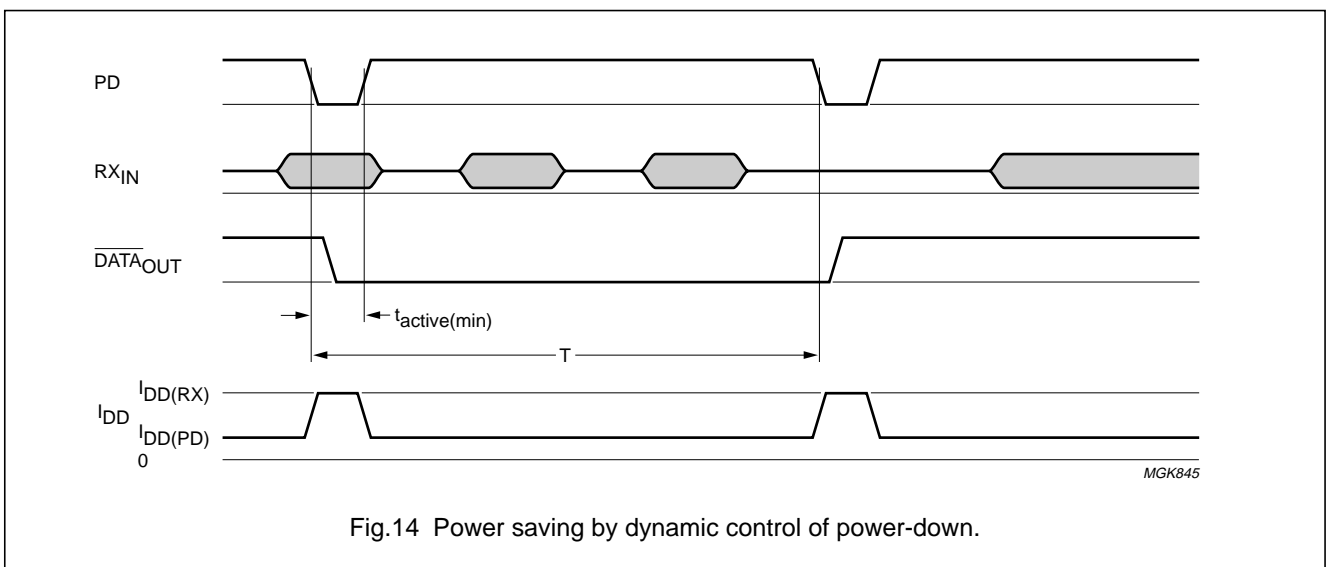
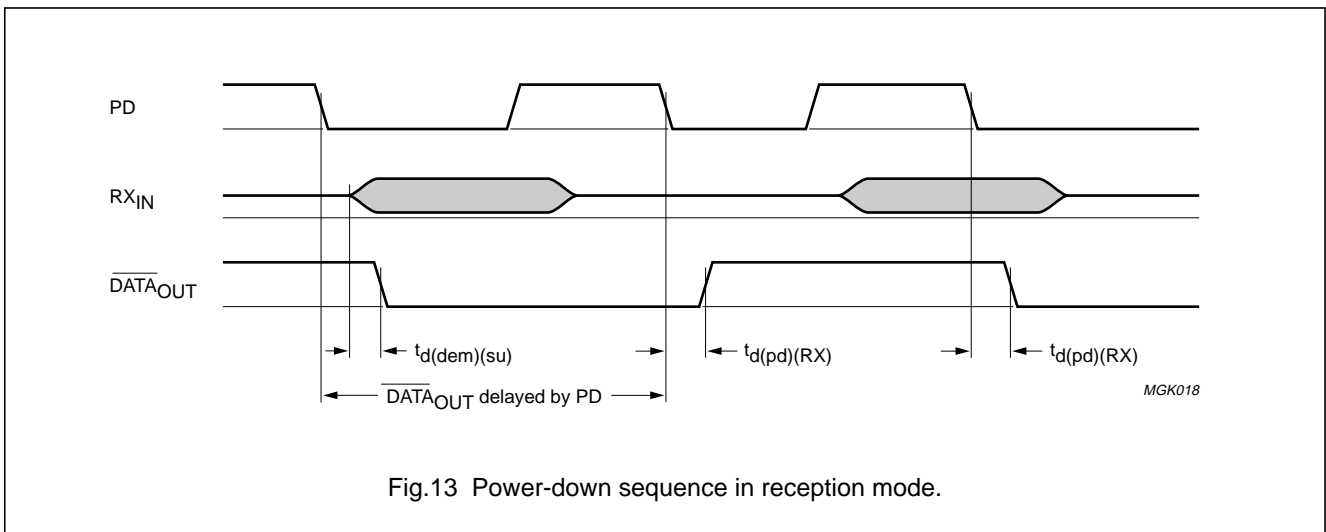
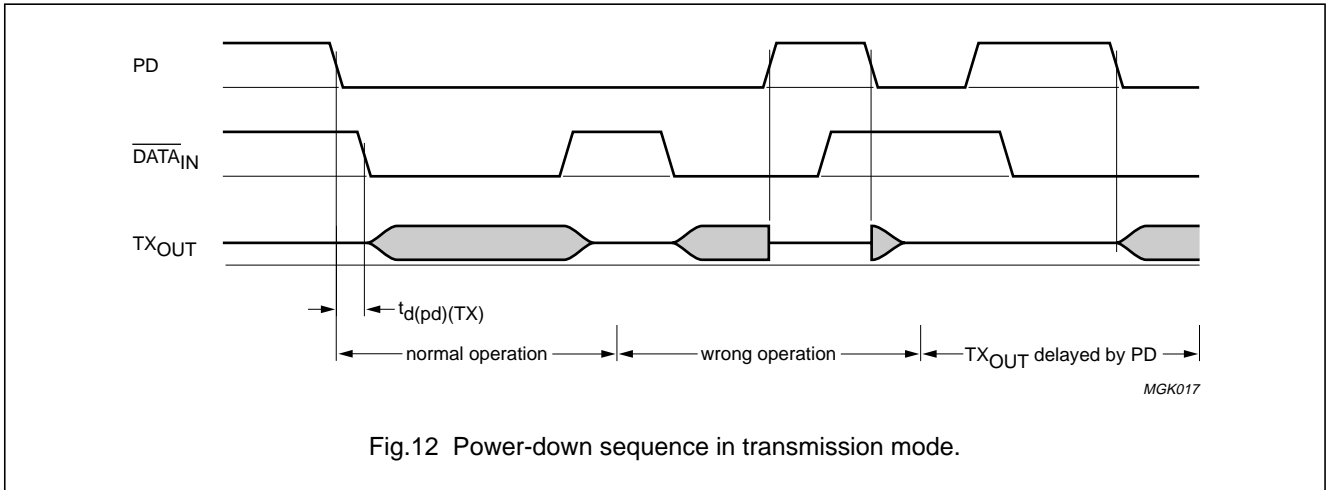

Home automation modem

TDA5051A

TEST INFORMATION

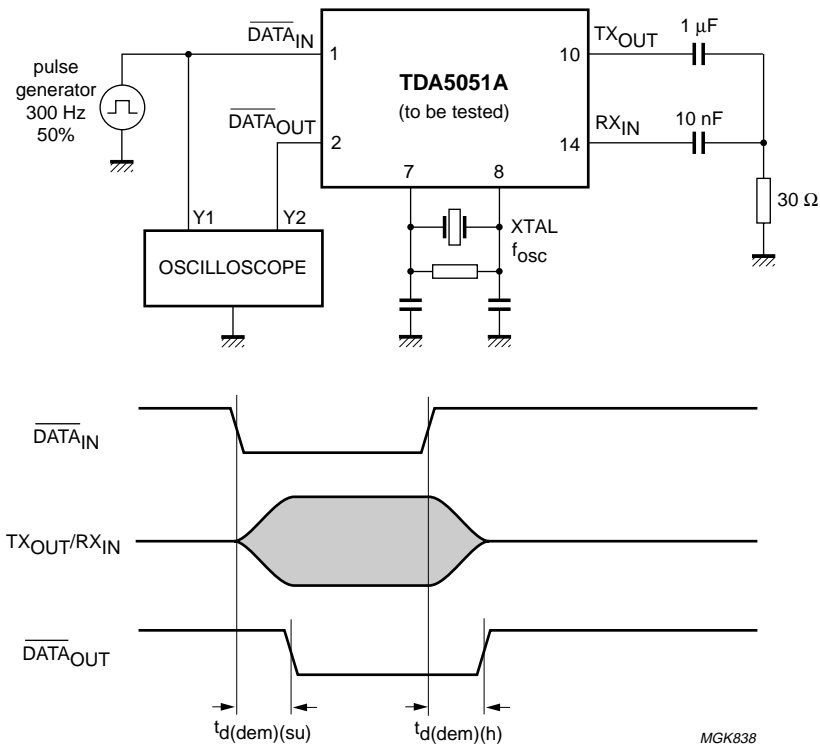
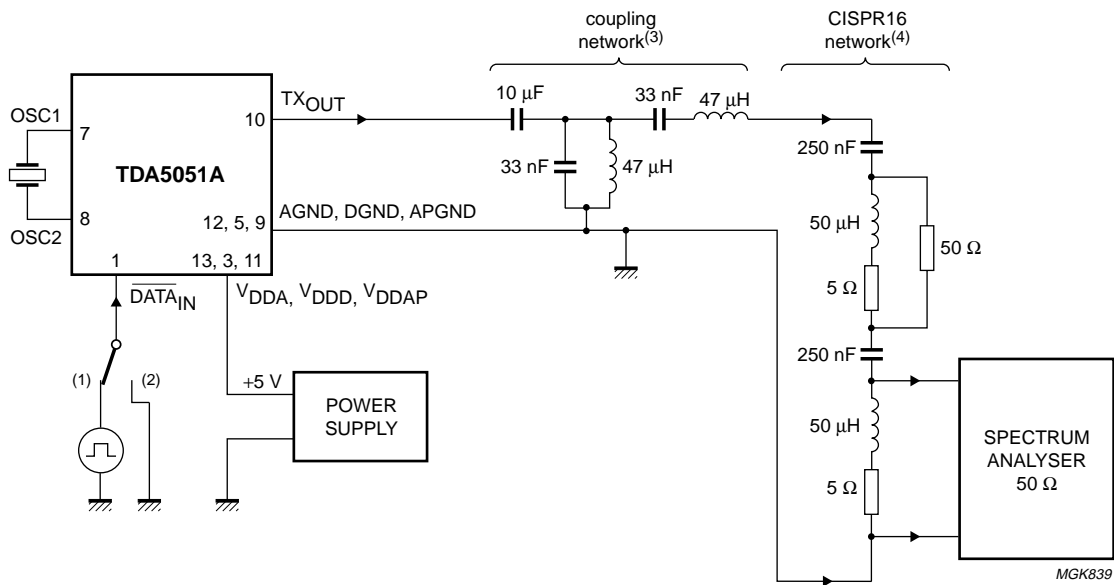

Fig.15 Test set-up for measuring demodulation delay.

Home automation modem

TDA5051A



- (1) Square wave TTL signal 300 Hz, duty factor = 50% for measuring signal bandwidth (see spectrum Fig.3).
- (2) $\overline{\text{DATA}}_{\text{IN}} = \text{LOW}$ for measuring total harmonic distortion (see spectrum Fig.3).
- (3) Tuned for $f_{cr} = 132.5 \text{ kHz}$.
- (4) The CISPR16 network provides a -6 dB attenuation.

Fig.16 Test set-up for measuring THD and bandwidth of the TX_OUT signal.

Home automation modem

TDA5051A

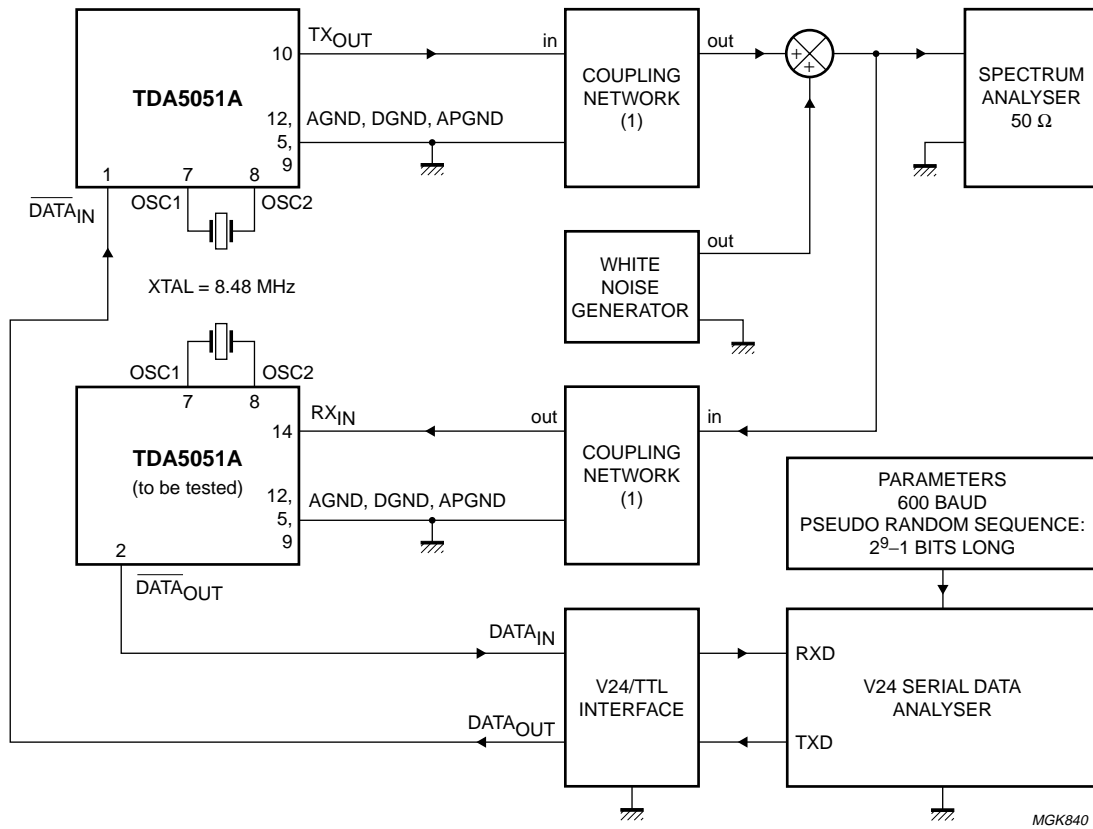

(1) See Fig.16.

Fig.17 Test set-up for measuring Bit Error Rate (BER).

Home automation modem

TDA5051A

APPLICATION INFORMATION

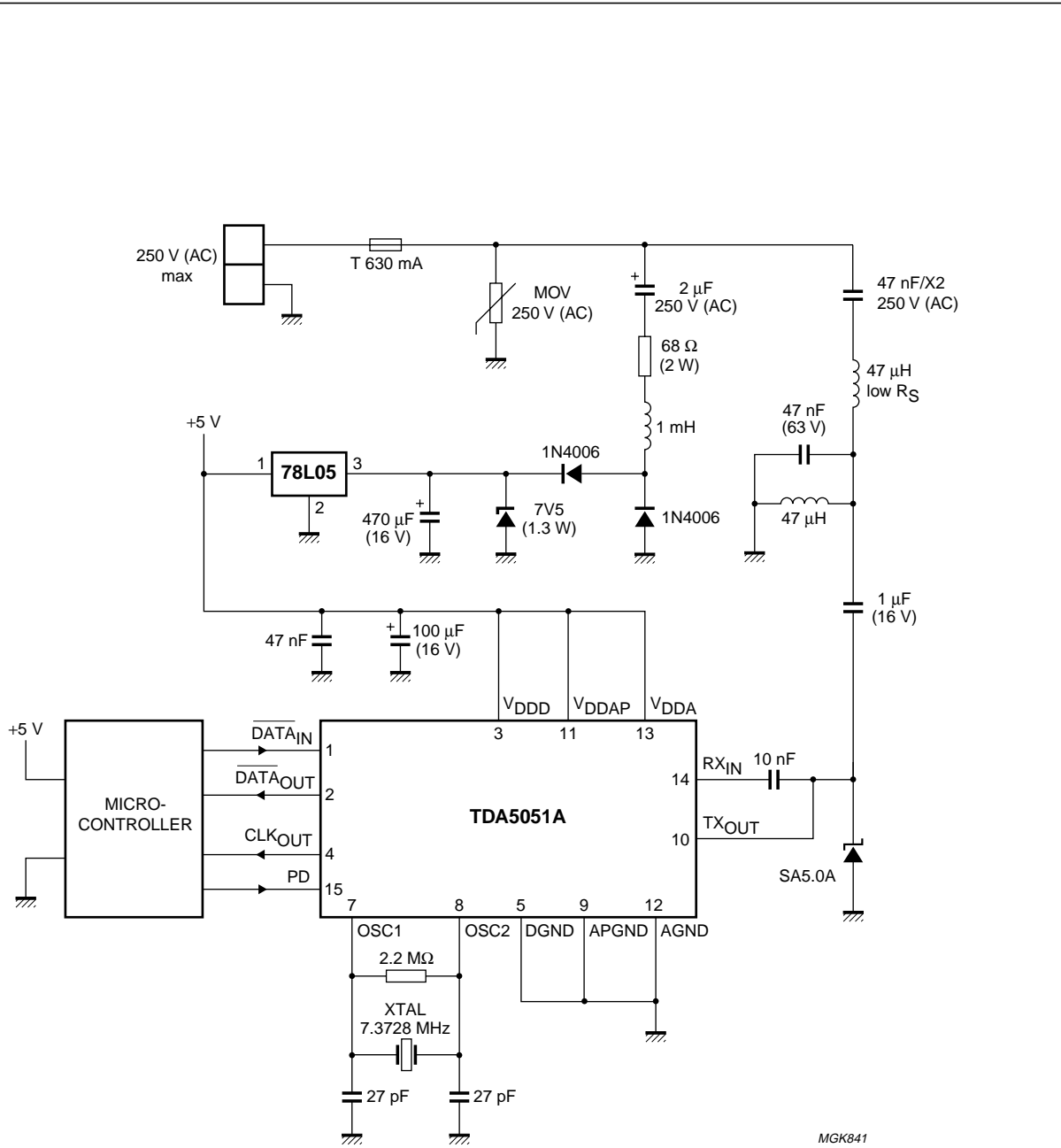

$f_{cr} = 115.2 \text{ kHz}$ for a XTAL = 7.3728 MHz standard crystal.

Fig.18 Application diagram without power line insulation.

Home automation modem

TDA5051A

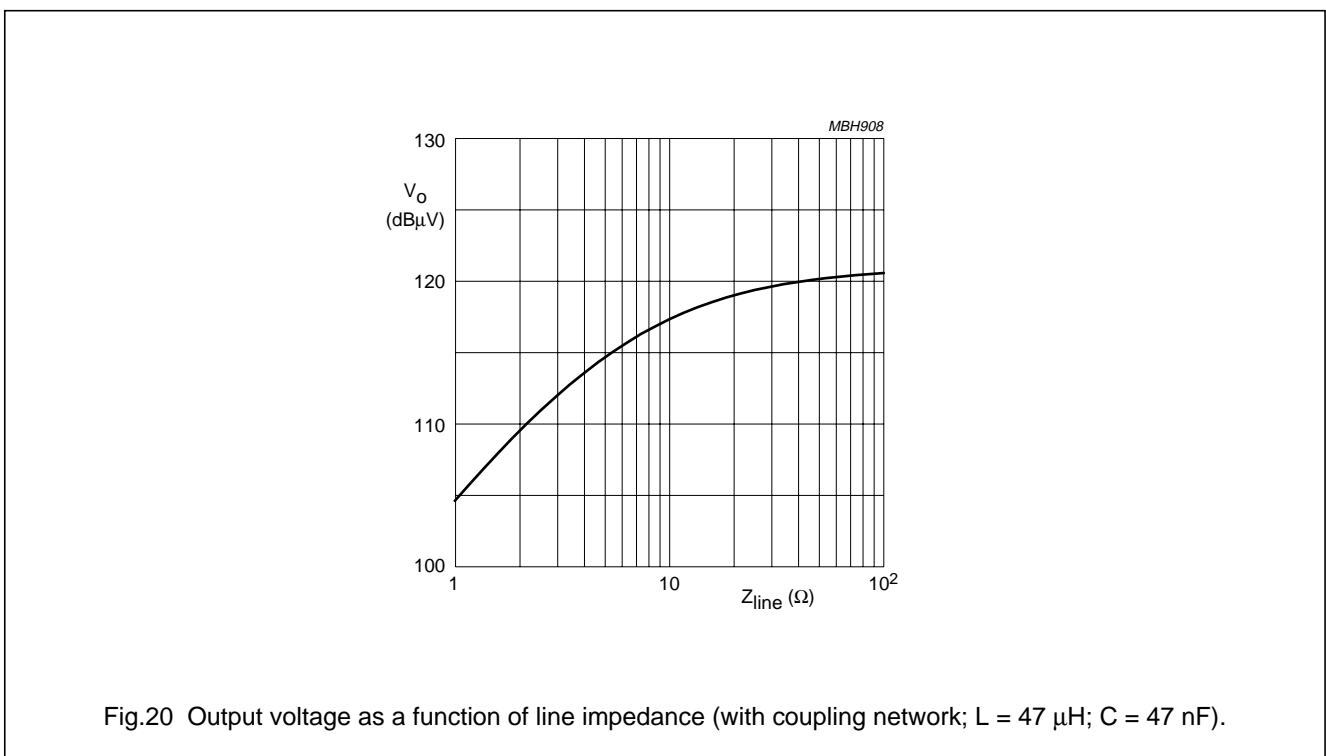
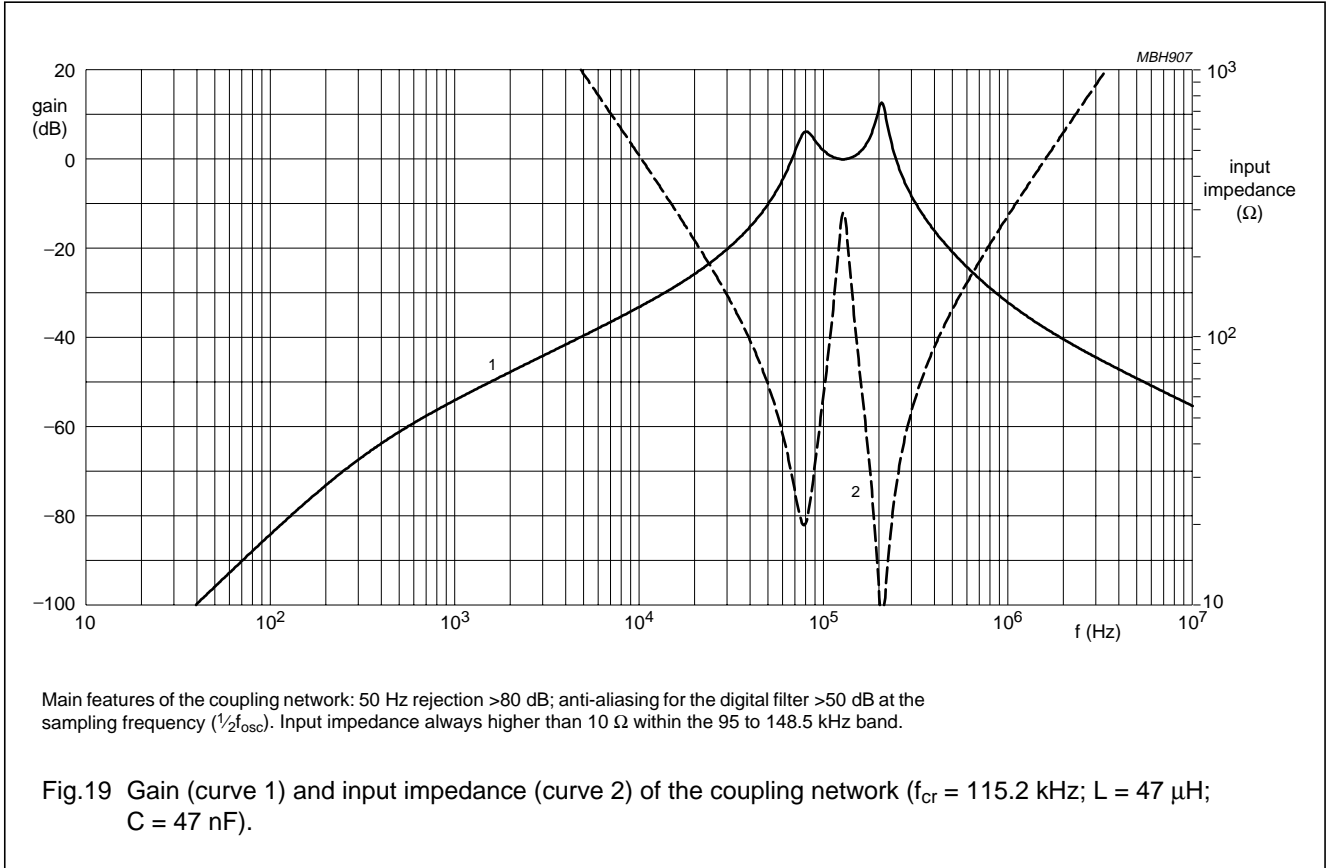

Home automation modem

TDA5051A

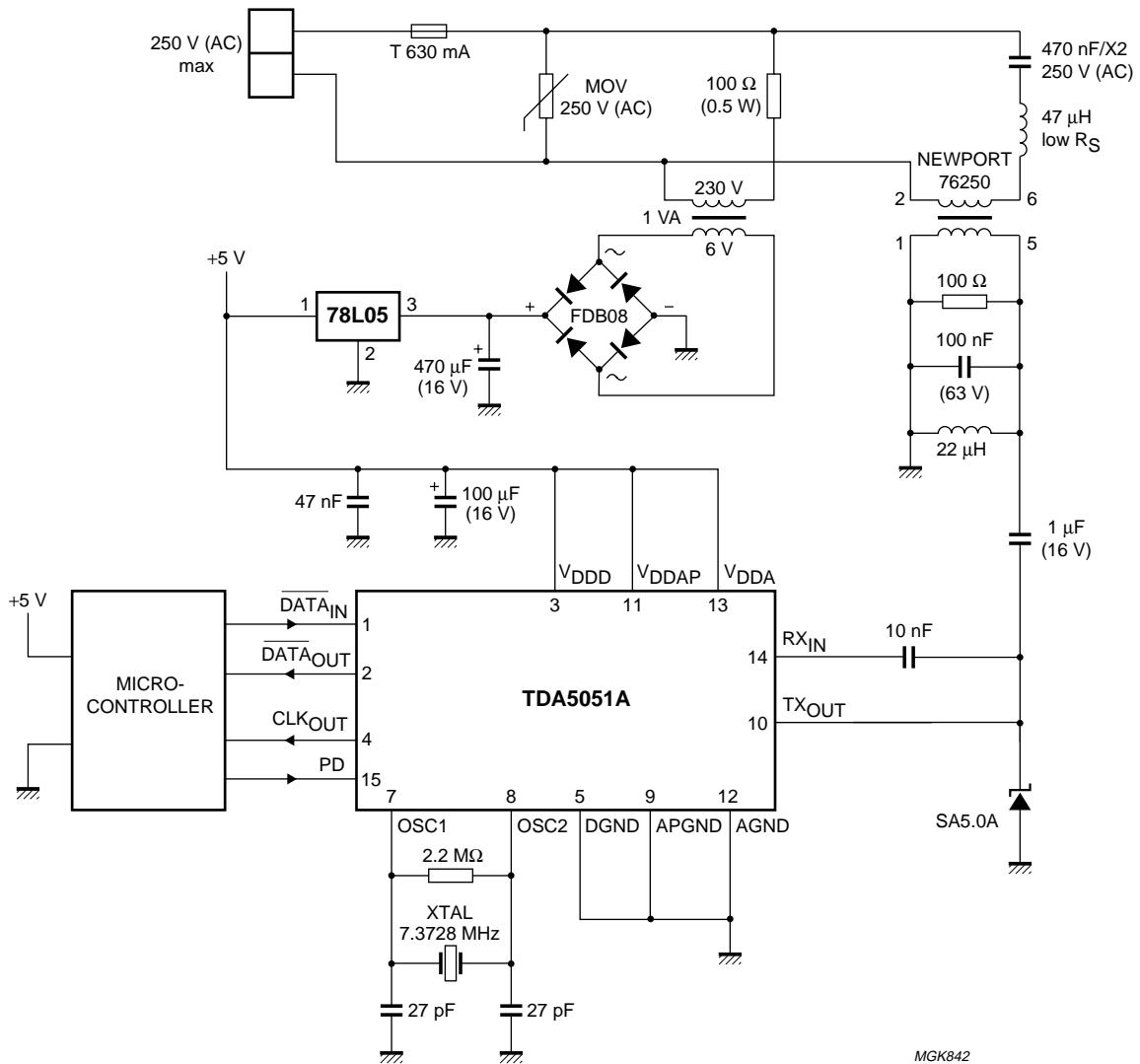

MGK842

$f_{cr} = 115.2 \text{ kHz}$ for a XTAL = 7.3728 MHz standard crystal.

Fig.21 Application diagram with power line insulation.

Home automation modem

TDA5051A

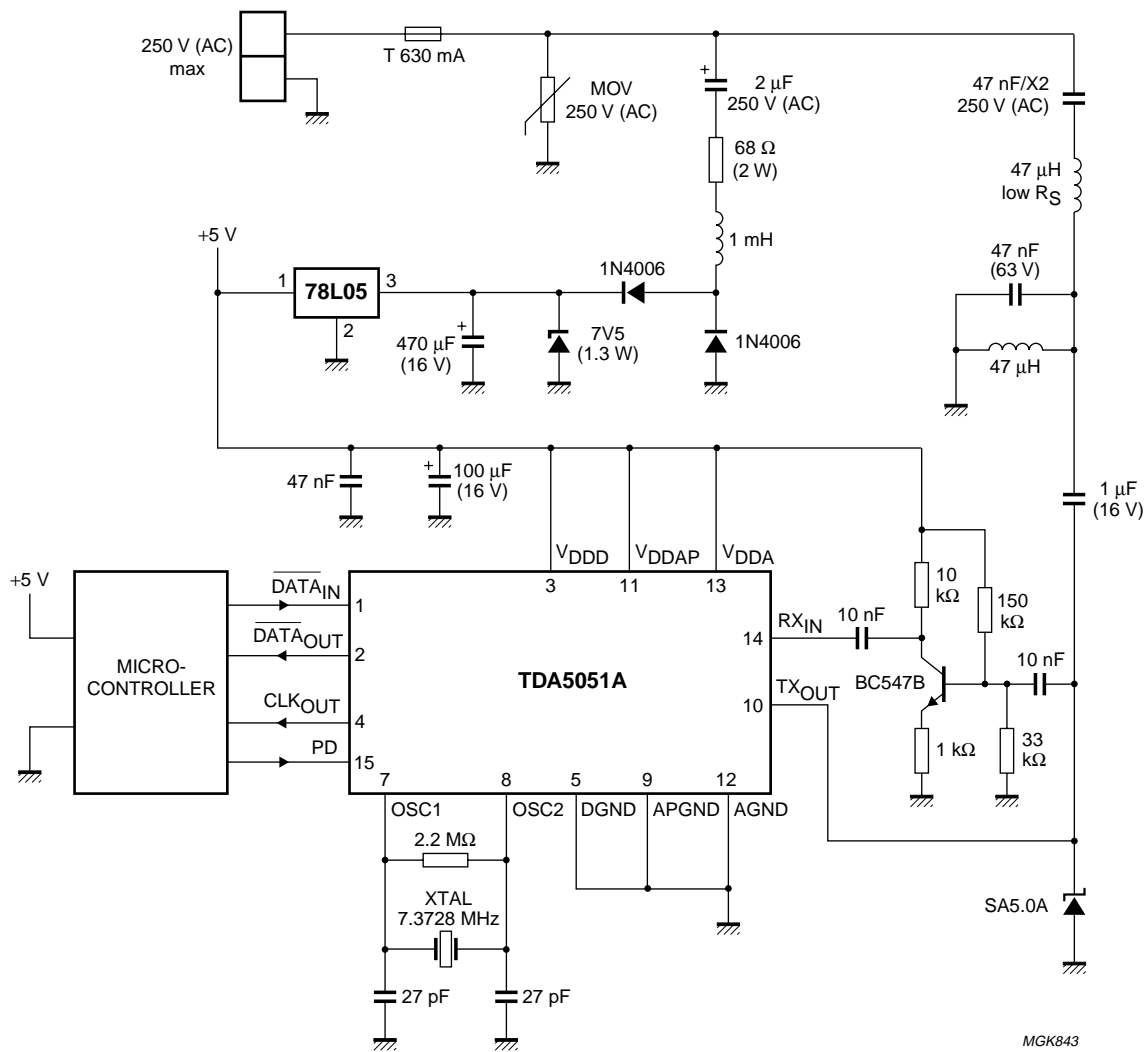

$f_{cr} = 115.2 \text{ kHz}$ for a XTAL = 7.3728 MHz standard crystal.

Fig.22 Application diagram without power line insulation, with improved sensitivity (68 dBµV typ.).

Home automation modem

TDA5051A

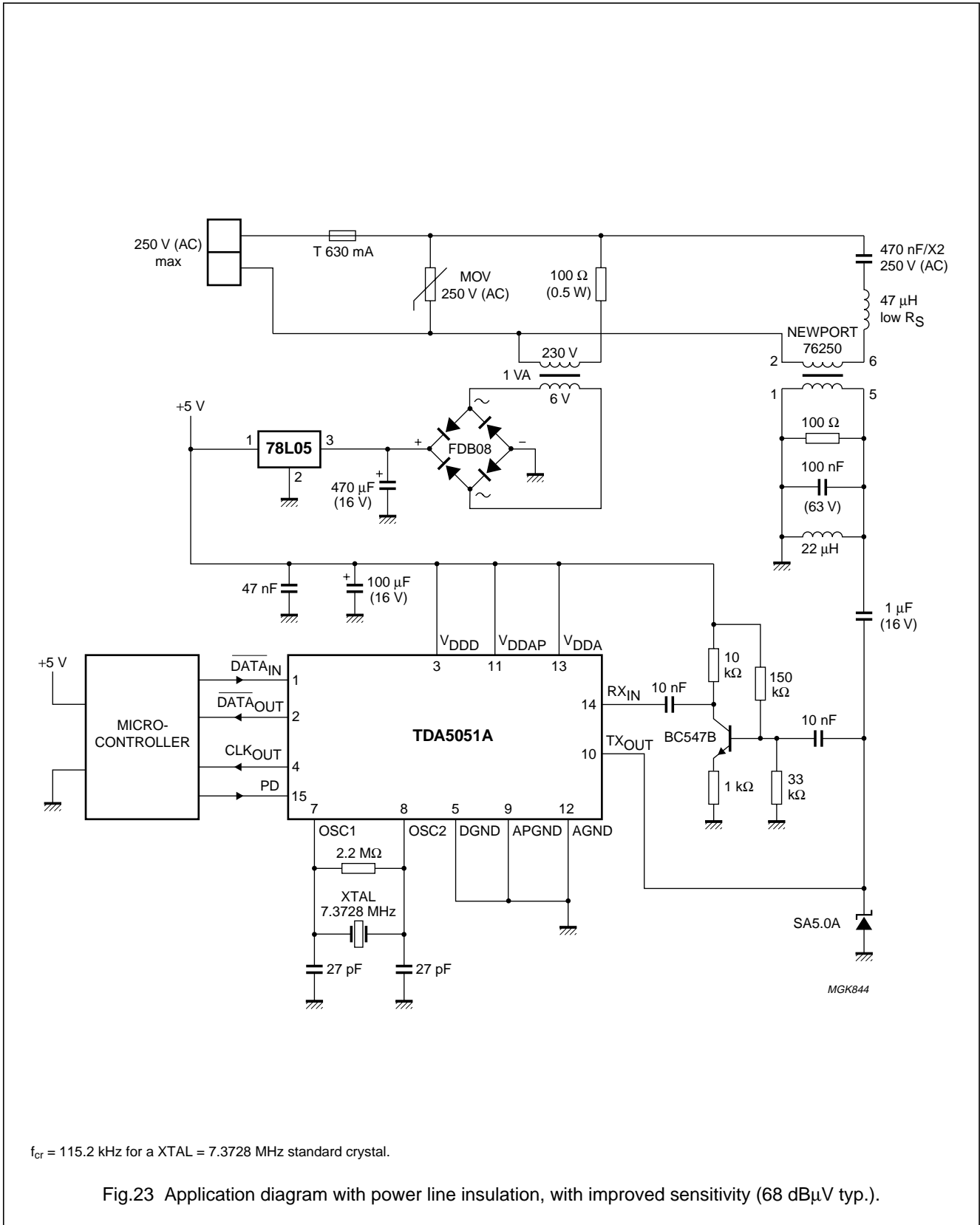

Home automation modem

TDA5051A

PACKAGE OUTLINE

SO16: plastic small outline package; 16 leads; body width 7.5 mm

SOT162-1

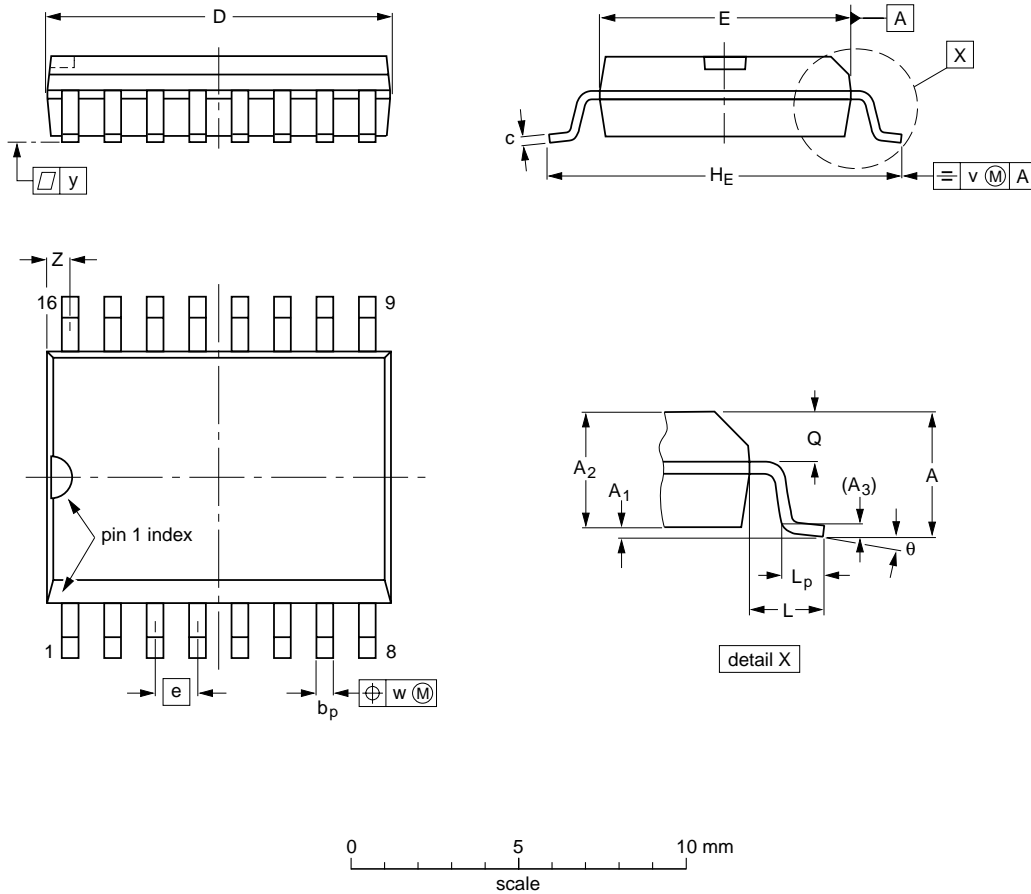

DIMENSIONS (inch dimensions are derived from the original mm dimensions)

UNIT	A max.	A ₁	A ₂	A ₃	b _p	c	D ⁽¹⁾	E ⁽¹⁾	e	H _E	L	L _p	Q	v	w	y	Z ⁽¹⁾	θ
mm	2.65	0.30 0.10	2.45 2.25	0.25	0.49 0.36	0.32 0.23	10.5 10.1	7.6 7.4	1.27	10.65 10.00	1.4	1.1 0.4	1.1 1.0	0.25	0.25	0.1	0.9 0.4	8° 0°
inches	0.10	0.012 0.004	0.096 0.089	0.01	0.019 0.014	0.013 0.009	0.41 0.40	0.30 0.29	0.050	0.419 0.394	0.055	0.043 0.016	0.043 0.039	0.01	0.01	0.004	0.035 0.016	

Note

1. Plastic or metal protrusions of 0.15 mm maximum per side are not included.

OUTLINE VERSION	REFERENCES			EUROPEAN PROJECTION	ISSUE DATE
	IEC	JEDEC	EIAJ		
SOT162-1	075E03	MS-013AA			95-01-24 97-05-22

Home automation modem

TDA5051A

SOLDERING

Introduction to soldering surface mount packages

This text gives a very brief insight to a complex technology. A more in-depth account of soldering ICs can be found in our *"Data Handbook IC26; Integrated Circuit Packages"* (document order number 9398 652 90011).

There is no soldering method that is ideal for all surface mount IC packages. Wave soldering is not always suitable for surface mount ICs, or for printed-circuit boards with high population densities. In these situations reflow soldering is often used.

Reflow soldering

Reflow soldering requires solder paste (a suspension of fine solder particles, flux and binding agent) to be applied to the printed-circuit board by screen printing, stencilling or pressure-syringe dispensing before package placement.

Several methods exist for reflowing; for example, infrared/convection heating in a conveyor type oven. Throughput times (preheating, soldering and cooling) vary between 100 and 200 seconds depending on heating method.

Typical reflow peak temperatures range from 215 to 250 °C. The top-surface temperature of the packages should preferably be kept below 230 °C.

Wave soldering

Conventional single wave soldering is not recommended for surface mount devices (SMDs) or printed-circuit boards with a high component density, as solder bridging and non-wetting can present major problems.

To overcome these problems the double-wave soldering method was specifically developed.

If wave soldering is used the following conditions must be observed for optimal results:

- Use a double-wave soldering method comprising a turbulent wave with high upward pressure followed by a smooth laminar wave.
- For packages with leads on two sides and a pitch (e):
 - larger than or equal to 1.27 mm, the footprint longitudinal axis is **preferred** to be parallel to the transport direction of the printed-circuit board;
 - smaller than 1.27 mm, the footprint longitudinal axis **must** be parallel to the transport direction of the printed-circuit board.

The footprint must incorporate solder thieves at the downstream end.

- For packages with leads on four sides, the footprint must be placed at a 45° angle to the transport direction of the printed-circuit board. The footprint must incorporate solder thieves downstream and at the side corners.

During placement and before soldering, the package must be fixed with a droplet of adhesive. The adhesive can be applied by screen printing, pin transfer or syringe dispensing. The package can be soldered after the adhesive is cured.

Typical dwell time is 4 seconds at 250 °C.

A mildly-activated flux will eliminate the need for removal of corrosive residues in most applications.

Manual soldering

Fix the component by first soldering two diagonally-opposite end leads. Use a low voltage (24 V or less) soldering iron applied to the flat part of the lead. Contact time must be limited to 10 seconds at up to 300 °C.

When using a dedicated tool, all other leads can be soldered in one operation within 2 to 5 seconds between 270 and 320 °C.

Home automation modem

TDA5051A

Suitability of surface mount IC packages for wave and reflow soldering methods

PACKAGE	SOLDERING METHOD	
	WAVE	REFLOW ⁽¹⁾
BGA, SQFP	not suitable	suitable
HLQFP, HSQFP, HSOP, HTSSOP, SMS	not suitable ⁽²⁾	suitable
PLCC ⁽³⁾ , SO, SOJ	suitable	suitable
LQFP, QFP, TQFP	not recommended ⁽³⁾⁽⁴⁾	suitable
SSOP, TSSOP, VSO	not recommended ⁽⁵⁾	suitable

Notes

1. All surface mount (SMD) packages are moisture sensitive. Depending upon the moisture content, the maximum temperature (with respect to time) and body size of the package, there is a risk that internal or external package cracks may occur due to vaporization of the moisture in them (the so called popcorn effect). For details, refer to the Drypack information in the "Data Handbook IC26; Integrated Circuit Packages; Section: Packing Methods".
2. These packages are not suitable for wave soldering as a solder joint between the printed-circuit board and heatsink (at bottom version) can not be achieved, and as solder may stick to the heatsink (on top version).
3. If wave soldering is considered, then the package must be placed at a 45° angle to the solder wave direction. The package footprint must incorporate solder thieves downstream and at the side corners.
4. Wave soldering is only suitable for LQFP, TQFP and QFP packages with a pitch (e) equal to or larger than 0.8 mm; it is definitely not suitable for packages with a pitch (e) equal to or smaller than 0.65 mm.
5. Wave soldering is only suitable for SSOP and TSSOP packages with a pitch (e) equal to or larger than 0.65 mm; it is definitely not suitable for packages with a pitch (e) equal to or smaller than 0.5 mm.

DEFINITIONS

Data sheet status	
Objective specification	This data sheet contains target or goal specifications for product development.
Preliminary specification	This data sheet contains preliminary data; supplementary data may be published later.
Product specification	This data sheet contains final product specifications.
Limiting values	
Limiting values given are in accordance with the Absolute Maximum Rating System (IEC 134). Stress above one or more of the limiting values may cause permanent damage to the device. These are stress ratings only and operation of the device at these or at any other conditions above those given in the Characteristics sections of the specification is not implied. Exposure to limiting values for extended periods may affect device reliability.	
Application information	
Where application information is given, it is advisory and does not form part of the specification.	

LIFE SUPPORT APPLICATIONS

These products are not designed for use in life support appliances, devices, or systems where malfunction of these products can reasonably be expected to result in personal injury. Philips customers using or selling these products for use in such applications do so at their own risk and agree to fully indemnify Philips for any damages resulting from such improper use or sale.

Home automation modem

TDA5051A

NOTES

Home automation modem

TDA5051A

NOTES

Philips Semiconductors – a worldwide company

Argentina: see South America

Australia: 34 Waterloo Road, NORTH RYDE, NSW 2113,
Tel. +61 2 9805 4455, Fax. +61 2 9805 4466

Austria: Computerstr. 6, A-1101 WIEN, P.O. Box 213,
Tel. +43 1 60 101 1248, Fax. +43 1 60 101 1210

Belarus: Hotel Minsk Business Center, Bld. 3, r. 1211, Volodarski Str. 6,
220050 MINSK, Tel. +375 172 20 0733, Fax. +375 172 20 0773

Belgium: see The Netherlands

Brazil: see South America

Bulgaria: Philips Bulgaria Ltd., Energoproject, 15th floor,
51 James Bourchier Blvd., 1407 SOFIA,
Tel. +359 2 68 9211, Fax. +359 2 68 9102

Canada: PHILIPS SEMICONDUCTORS/COMPONENTS,
Tel. +1 800 234 7381, Fax. +1 800 943 0087

China/Hong Kong: 501 Hong Kong Industrial Technology Centre,
72 Tat Chee Avenue, Kowloon Tong, HONG KONG,
Tel. +852 2319 7888, Fax. +852 2319 7700

Colombia: see South America

Czech Republic: see Austria

Denmark: Sydhavnsgade 23, 1780 COPENHAGEN V,
Tel. +45 33 29 3333, Fax. +45 33 29 3905

Finland: Sinikalliontie 3, FIN-02630 ESPOO,
Tel. +358 9 615 800, Fax. +358 9 6158 0920

France: 51 Rue Carnot, BP317, 92156 SURESNES Cedex,
Tel. +33 1 4099 6161, Fax. +33 1 4099 6427

Germany: Hammerbrookstraße 69, D-20097 HAMBURG,
Tel. +49 40 2353 60, Fax. +49 40 2353 6300

Hungary: see Austria

India: Philips INDIA Ltd, Band Box Building, 2nd floor,
254-D, Dr. Annie Besant Road, Worli, MUMBAI 400 025,
Tel. +91 22 493 8541, Fax. +91 22 493 0966

Indonesia: PT Philips Development Corporation, Semiconductors Division,
Gedung Philips, Jl. Buncit Raya Kav.99-100, JAKARTA 12510,
Tel. +62 21 794 0040 ext. 2501, Fax. +62 21 794 0080

Ireland: Newstead, Clonskeagh, DUBLIN 14,
Tel. +353 1 7640 000, Fax. +353 1 7640 200

Israel: RAPAC Electronics, 7 Kehilat Saloniki St, PO Box 18053,
TEL AVIV 61180, Tel. +972 3 645 0444, Fax. +972 3 649 1007

Italy: PHILIPS SEMICONDUCTORS, Piazza IV Novembre 3,
20124 MILANO, Tel. +39 02 67 52 2531, Fax. +39 02 67 52 2557

Japan: Philips Bldg 13-37, Kohnan 2-chome, Minato-ku,
TOKYO 108-8507, Tel. +81 3 3740 5130, Fax. +81 3 3740 5057

Korea: Philips House, 260-199 Itaewon-dong, Yongsan-ku, SEOUL,
Tel. +82 2 709 1412, Fax. +82 2 709 1415

Malaysia: No. 76 Jalan Universiti, 46200 PETALING JAYA, SELANGOR,
Tel. +60 3 750 5214, Fax. +60 3 757 4880

Mexico: 5900 Gateway East, Suite 200, EL PASO, TEXAS 79905,
Tel. +9-5 800 234 7381, Fax +9-5 800 943 0087

Middle East: see Italy

Netherlands: Postbus 90050, 5600 PB EINDHOVEN, Bldg. VB,
Tel. +31 40 27 82785, Fax. +31 40 27 88399

New Zealand: 2 Wagener Place, C.P.O. Box 1041, AUCKLAND,
Tel. +64 9 849 4160, Fax. +64 9 849 7811

Norway: Box 1, Manglerud 0612, OSLO,
Tel. +47 22 74 8000, Fax. +47 22 74 8341

Pakistan: see Singapore

Philippines: Philips Semiconductors Philippines Inc.,
106 Valero St. Salcedo Village, P.O. Box 2108 MCC, MAKATI,
Metro MANILA, Tel. +63 2 816 6380, Fax. +63 2 817 3474

Poland: Ul. Lukiska 10, PL 04-123 WARSZAWA,
Tel. +48 22 612 2831, Fax. +48 22 612 2327

Portugal: see Spain

Romania: see Italy

Russia: Philips Russia, Ul. Usatcheva 35A, 119048 MOSCOW,
Tel. +7 095 755 6918, Fax. +7 095 755 6919

Singapore: Lorong 1, Toa Payoh, SINGAPORE 319762,
Tel. +65 350 2538, Fax. +65 251 6500

Slovakia: see Austria

Slovenia: see Italy

South Africa: S.A. PHILIPS Pty Ltd., 195-215 Main Road Martindale,
2092 JOHANNESBURG, P.O. Box 58088 Newville 2114,
Tel. +27 11 471 5401, Fax. +27 11 471 5398

South America: Al. Vicente Pinzon, 173, 6th floor,
04547-130 SÃO PAULO, SP, Brazil,
Tel. +55 11 821 2333, Fax. +55 11 821 2382

Spain: Balmes 22, 08007 BARCELONA,
Tel. +34 93 301 6312, Fax. +34 93 301 4107

Sweden: Kottbygatan 7, Akalla, S-16485 STOCKHOLM,
Tel. +46 8 5985 2000, Fax. +46 8 5985 2745

Switzerland: Allmendstrasse 140, CH-8027 ZÜRICH,
Tel. +41 1 488 2741 Fax. +41 1 488 3263

Taiwan: Philips Semiconductors, 6F, No. 96, Chien Kuo N. Rd., Sec. 1,
TAIPEI, Taiwan Tel. +886 2 2134 2886, Fax. +886 2 2134 2874

Thailand: PHILIPS ELECTRONICS (THAILAND) Ltd.,
209/2 Sanpavuth-Bangna Road Prakanong, BANGKOK 10260,
Tel. +66 2 745 4090, Fax. +66 2 398 0793

Turkey: Yukari Dudullu, Org. San. Blg., 2.Cad. Nr. 28 81260 Umraniye,
ISTANBUL, Tel. +90 216 522 1500, Fax. +90 216 522 1813

Ukraine: PHILIPS UKRAINE, 4 Patrice Lumumba str., Building B, Floor 7,
252042 KIEV, Tel. +380 44 264 2776, Fax. +380 44 268 0461

United Kingdom: Philips Semiconductors Ltd., 276 Bath Road, Hayes,
MIDDLESEX UB3 5BX, Tel. +44 181 730 5000, Fax. +44 181 754 8421

United States: 811 East Arques Avenue, SUNNYVALE, CA 94088-3409,
Tel. +1 800 234 7381, Fax. +1 800 943 0087

Uruguay: see South America

Vietnam: see Singapore

Yugoslavia: PHILIPS, Trg N. Pasica 5/v, 11000 BEOGRAD,
Tel. +381 11 62 5344, Fax. +381 11 63 5777

For all other countries apply to: Philips Semiconductors,
International Marketing & Sales Communications, Building BE-p, P.O. Box 218,
5600 MD EINDHOVEN, The Netherlands, Fax. +31 40 27 24825

Internet: <http://www.semiconductors.philips.com>

© Philips Electronics N.V. 1999

SCA 65

All rights are reserved. Reproduction in whole or in part is prohibited without the prior written consent of the copyright owner.

The information presented in this document does not form part of any quotation or contract, is believed to be accurate and reliable and may be changed without notice. No liability will be accepted by the publisher for any consequence of its use. Publication thereof does not convey nor imply any license under patent- or other industrial or intellectual property rights.

Printed in The Netherlands

295002/25/02/pp28

Date of release: 1999 May 31

Document order number: 9397 750 05035

Let's make things better.

Philips



PHILIPS