

**INTEGRATED CIRCUITS**

# DATA SHEET

## **TDA5147CH**

**12 V Voice Coil Motor (VCM) driver  
and spindle motor drive  
combination chip**

Preliminary specification  
File under Integrated Circuits, IC11

1997 Jul 09

# 12 V Voice Coil Motor (VCM) driver and spindle motor drive combination chip

## TDA5147CH

### FEATURES

#### Spindle motor driver

- Internal 2 A peak current power drivers
- Low  $R_{ds(on)}$  (1  $\Omega$  maximum total) for high, low and isolation drivers
- Induction sense start-up option
- External current sense resistor
- Soft switching on both upper and lower drivers
- Programmable linear or Pulse Width Modulation (PWM) spindle mode
- Provide spindle active dynamic braking mode.

#### Voice coil motor driver

- 1.2 A VCM power driver
- Maximum of 1 V drop across the power driver at 0.8 A
- External current sense resistor, with sense amplifier
- External current control loop compensation
- 15 kHz (typ.) VCM current control loop bandwidth
- Three modes of operation:
  - Enable VCM
  - Retract
  - Disable
- Brake after park circuitry.

#### Power monitor and retract circuit

- +5 V and +12 V power monitor threshold accuracy  $\pm 2\%$
- Hysteresis on both power monitor comparators
- Internal voltage reference: precision 2%
- Buffered reference voltage output pin

- Retract circuit operates down to 2 V
- Internal thermal sense circuitry with an over temperature shut down option
- Internal boost voltage generator
- Sleep mode.

#### Thermal warning circuit

- Output active 15 °C before general thermal shutdown.

### APPLICATIONS

- Hard disk drive for Personal Computer products.

### GENERAL DESCRIPTION

The TDA5147CH is an ASIC combination chip that includes the following functions:

- spindle motor driver
- voice coil motor driver
- retract
- Power-on.

The circuit is contained in a 64-pin QFP package.

The TDA5147CH is controlled by a custom digital ASIC (see Chapter "Application Information"). The custom ASIC provides the necessary commutation sequences for the spindle drivers via the SCNTL1, SCNTL2 and SCNTL3 inputs. Spindle speed is monitored by comparator outputs SENU, SENV and SENWIS. Motor speed control is accomplished by a PWM signal (input at pin SIPWM).

Control of the VCM circuits is via the  $V_{IPWMH}$  and  $V_{IPWML}$  input signals. These inputs provide control of the voice coil current.

### ORDERING INFORMATION

TYPE NUMBER	PACKAGE		
	NAME	DESCRIPTION	VERSION
TDA5147CH	QFP64	plastic quad flat package; 64 leads (lead length 1.6 mm); body 14 × 14 × 2.7 mm	SOT393-1

---

**12 V Voice Coil Motor (VCM) driver and spindle motor drive combination chip**

---

**TDA5147CH****QUICK REFERENCE DATA**

SYMBOL	PARAMETER	MIN.	TYP.	MAX.	UNIT
<b>Supply voltage</b>					
V <sub>CC5</sub>	analog supply voltage 1	4.5	5.0	5.5	V
V <sub>CCA12</sub>	analog supply voltage 2	10.8	12	13.2	V
V <sub>CCS12</sub>	power supply for spindle motor drivers	10.8	12	13.2	V
V <sub>CC1V12</sub>	power supply 1 for VCM driver	10.8	12	13.2	V
V <sub>CC2V12</sub>	power supply 2 for VCM driver	10.8	12	13.2	V
<b>Drivers</b>					
I <sub>spin(max)</sub>	maximum spindle current	–	2	–	A
I <sub>VCM(max)</sub>	maximum VCM current	–	1.2	–	A

# 12 V Voice Coil Motor (VCM) driver and spindle motor drive combination chip

TDA5147CH

## BLOCK DIAGRAMS

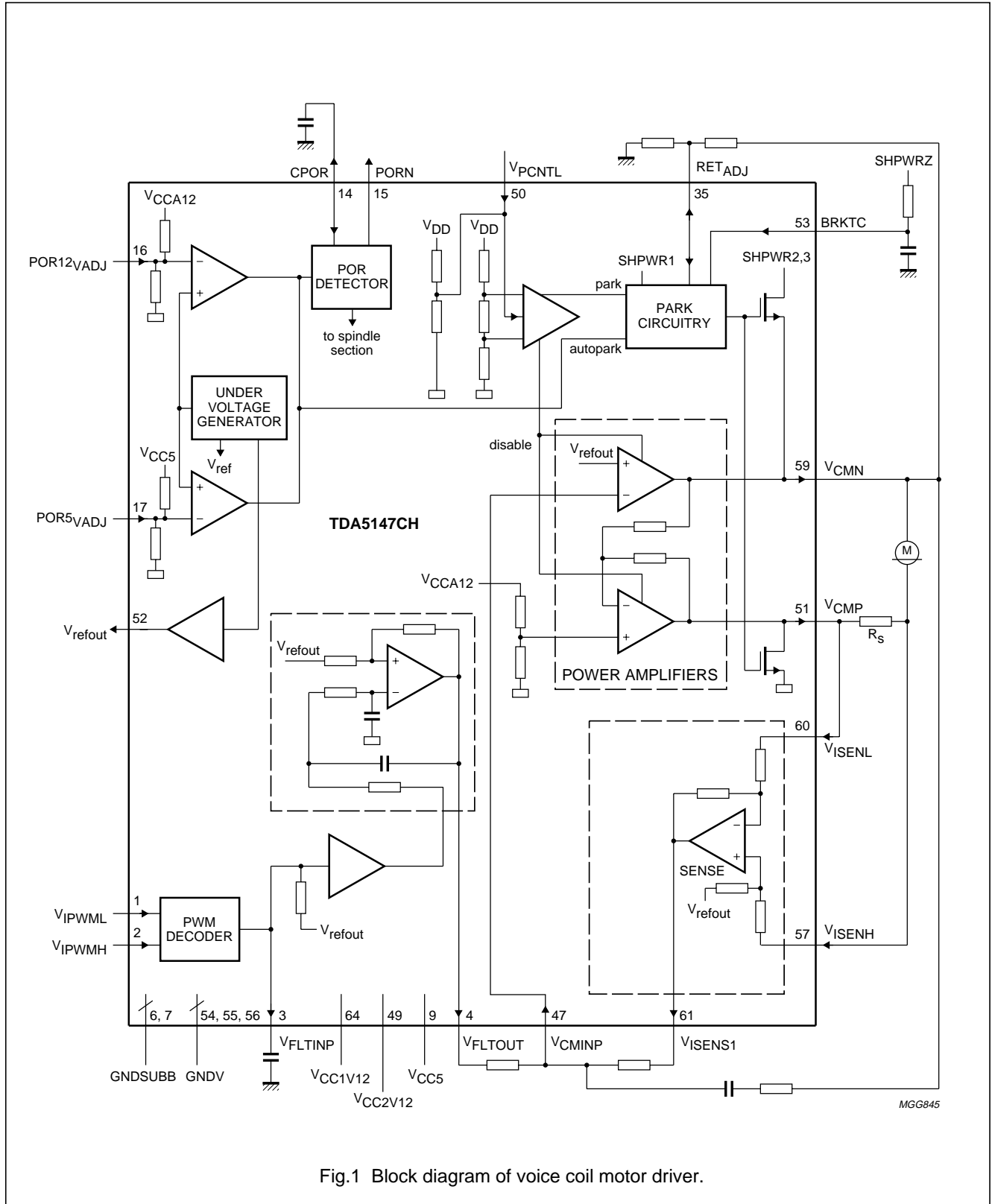

Fig.1 Block diagram of voice coil motor driver.

# 12 V Voice Coil Motor (VCM) driver and spindle motor drive combination chip

## TDA5147CH

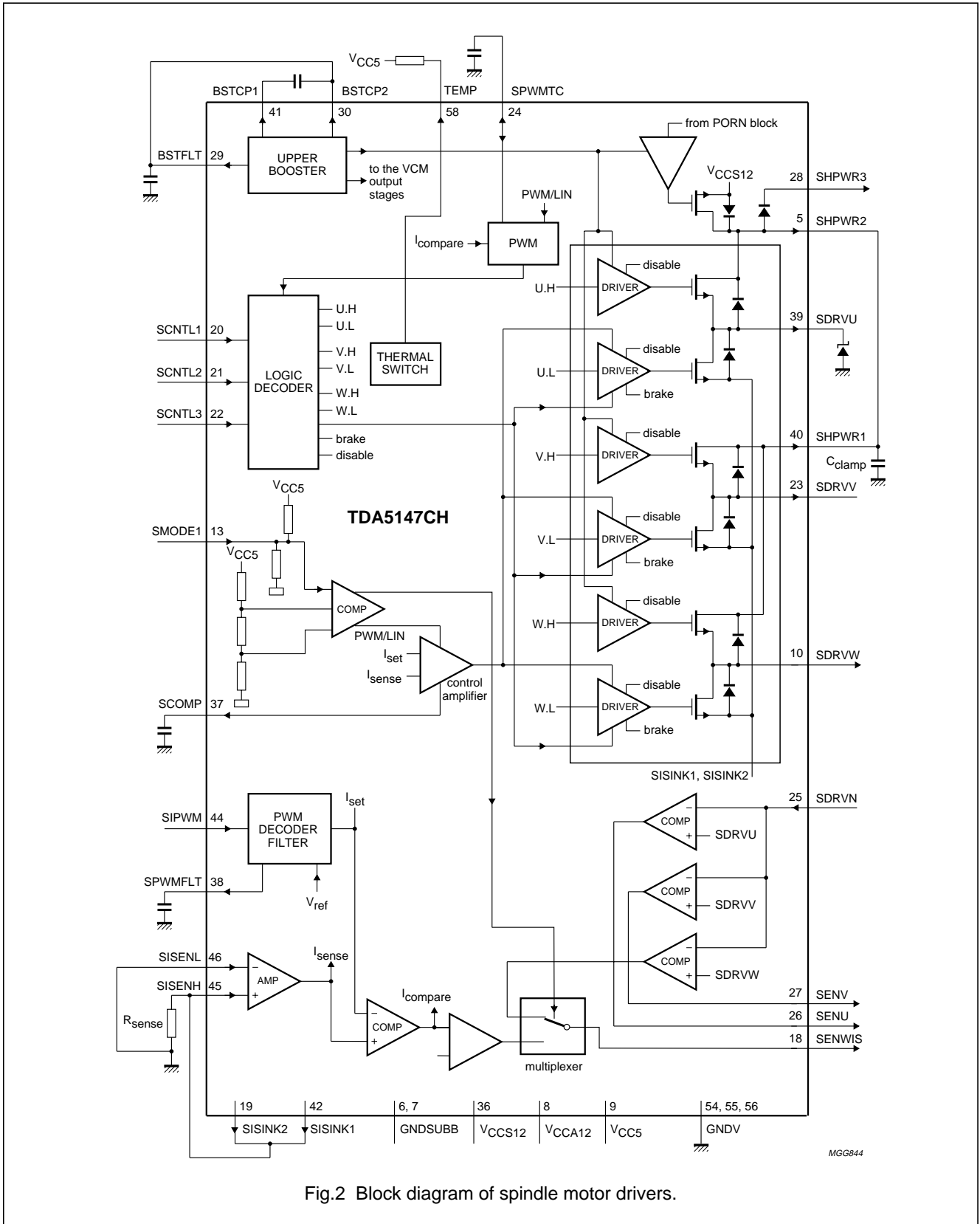

Fig.2 Block diagram of spindle motor drivers.

# 12 V Voice Coil Motor (VCM) driver and spindle motor drive combination chip

## TDA5147CH

### PINNING

SYMBOL	PIN	I/O	DESCRIPTION
V <sub>IPWML</sub>	1	I	LSB PWM input
V <sub>IPWMH</sub>	2	I	MSB PWM input
V <sub>FLTINP</sub>	3	O	voice coil motor PWM filter capacitor
V <sub>FLTOUT</sub>	4	O	PWM filter output voltage
SHPWR2	5	O	capacitor for park supply voltage
GNDSUBB	6	–	analog ground 2
GNDSUBB	7	–	analog ground 2
V <sub>CCA12</sub>	8	–	analog supply voltage 2 (+12 V)
V <sub>CC5</sub>	9	–	analog supply voltage 1 (+5 V)
SDRVV	10	O	phase 3 output for spindle motor
n.c.	11	–	not connected
n.c.	12	–	not connected
SMODE1	13	–	3 level input for spindle mode
CPOR	14	I/O	Power-on reset delay capacitor
PORN	15	O	Power-on reset digital output (active LOW)
POR12 <sub>VADJ</sub>	16	I	adjustment of PORN threshold (for +12 V)
POR5 <sub>VADJ</sub>	17	I	adjustment of PORN threshold (for +5 V)
SENWIS	18	O	digital output of back EMF sense 3/inductive sense
SISINK2	19	O	connection 2 to the sense resistor
SCNTL1	20	I	digital input 1 for spindle decoder
SCNTL2	21	I	digital input 2 for spindle decoder
SCNTL3	22	I	digital input 3 for spindle decoder
SDRVV	23	O	phase 2 output for spindle motor
SPWMTC	24	I/O	capacitor for spindle low side PWM time off
SDRVN	25	O	centre TAP connection to spindle motor
SENU	26	O	digital output of back EMF sense 1

SYMBOL	PIN	I/O	DESCRIPTION
SENV	27	O	digital output of back EMF sense 2
SHPWR3	28	O	capacitor 3 for park supply voltage
BSTFLT	29	O	booster filter output
BSTCP2	30	O	booster capacitor 2 output
n.c.	31	–	not connected
n.c.	32	–	not connected
n.c.	33	–	not connected
n.c.	34	–	not connected
RET <sub>ADJ</sub>	35	I/O	retract voltage adjustment pin
V <sub>CCS12</sub>	36	–	power supply of spindle motor drivers (+12 V)
SCOMP	37	O	control amplifier pole adjustment
SPWMFLT	38	I/O	capacitor for spindle PWM filter
SDRVU	39	O	phase 1 output for spindle motor
SHPWR1	40	O	capacitor 1 for park supply voltage
BSTCP1	41	O	booster capacitor 1 output
SISINK1	42	O	connection 1 to the sense resistor
GNDSUBA	43	–	analog ground 1
SIPWM	44	I	digital PWM input for spindle current
SISENH	45	I	sense resistor for spindle current
SISENL	46	I	isolated ground connection for spindle sense amplifier
V <sub>CMINP</sub>	47	I	closed loop voltage compensation of VCM
n.c.	48	–	not connected
V <sub>CC2V12</sub>	49	–	+12 V power supply of VCM driver
V <sub>PCNTL</sub>	50	I	park enable 3-level input
V <sub>COMP</sub>	51	O	positive output voltage of H-Bridge
V <sub>refout</sub>	52	O	output reference for external ADC
BRKTC	53	I	input for setting brake after park time

# 12 V Voice Coil Motor (VCM) driver and spindle motor drive combination chip

## TDA5147CH

SYMBOL	PIN	I/O	DESCRIPTION
GNDV	54	–	power ground 2 of voice coil motor driver
GNDV	55	–	power ground 2 of voice coil motor driver
GNDV	56	–	power ground 2 of voice coil motor driver
V <sub>ISENH</sub>	57	I	positive input voltage of sense resistor amplifier
TEMP	58	O	open collector output for early thermal warning

SYMBOL	PIN	I/O	DESCRIPTION
V <sub>CMN</sub>	59	O	negative output voltage of H-Bridge
V <sub>ISENL</sub>	60	I	negative input voltage of sense resistor amplifier
V <sub>ISENS1</sub>	61	O	voltage output 1 of sense resistor amplifier
n.c.	62	–	not connected
n.c.	63	–	not connected
V <sub>CC1V12</sub>	64	–	+12 V power supply of VCM driver

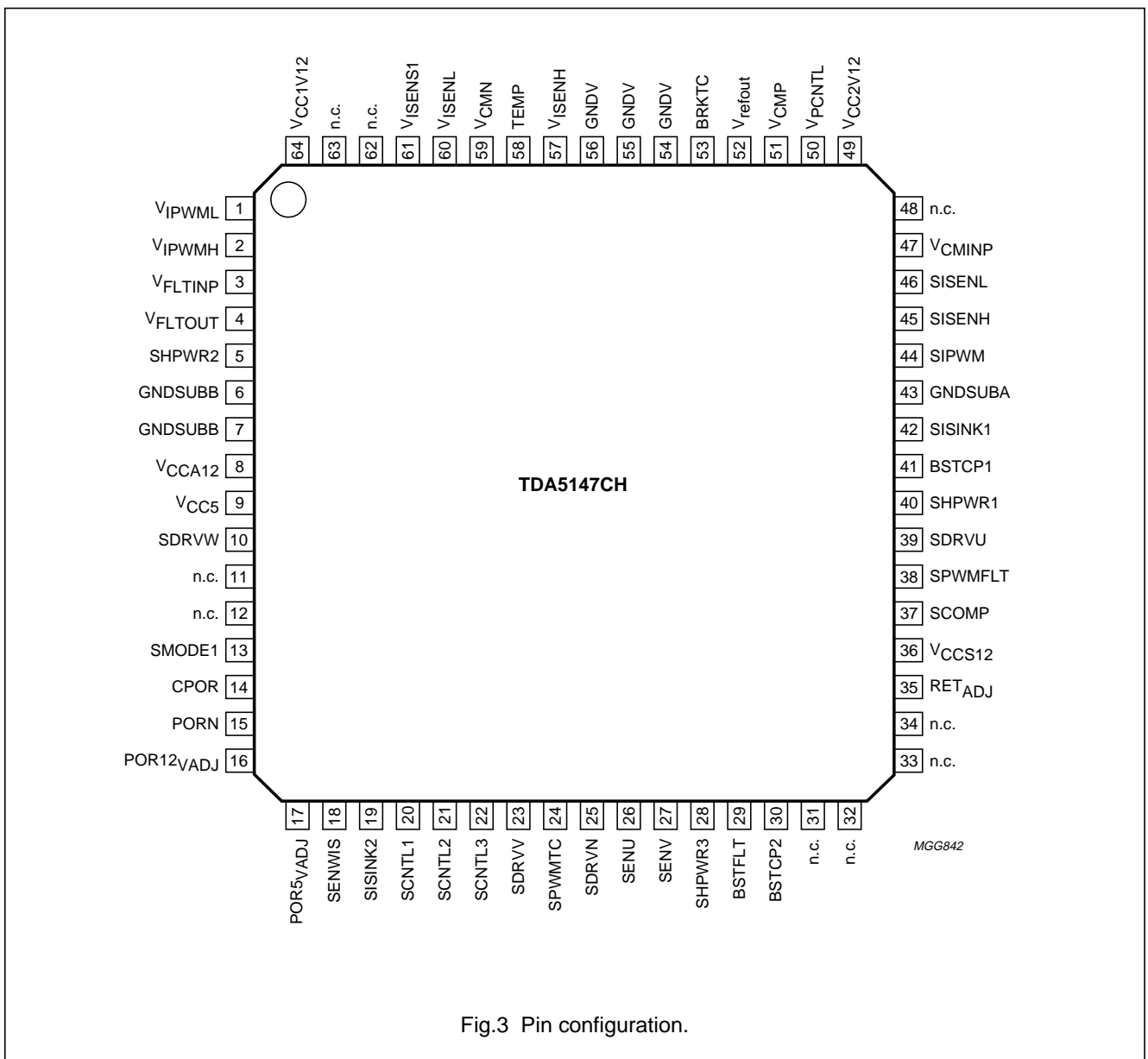

Fig.3 Pin configuration.

# 12 V Voice Coil Motor (VCM) driver and spindle motor drive combination chip

## TDA5147CH

### FUNCTIONAL DESCRIPTION

#### Spindle drivers

The spindle section (see Fig.2) contains both the low and high side drivers (configured as H bridges) for a three-phase DC brushless motor. Back EMF (Electro Motive Force) sensing of the commutation rate (pin SENWIS) is an output to an external digital ASIC circuit. This circuit should provide the input commutation control as well. Consequently, all speed control, start-up routine and commutation control will be generated by the external digital circuit.

The SIPWM signal from the digital circuit is used to control the spindle current. This PWM signal is internally filtered. The output of this filter depends solely on the duty factor. The pole location of this first order low-pass filter is controlled by an external capacitor at pin SPWMFLT.

Dynamic braking is possible only during non power-down situations and must be initiated by the digital circuit.

A 3- level mode line (pin SMODE1) allows for:

- Induction sensing in pre-start-up (SMODE1 = 0.5V<sub>CC5</sub> or high impedance)
- PWM control during start-up (SMODE1 = 0 V)
- Linear control (SMODE1 = V<sub>CC5</sub>).

#### SENSING MODE

The induction sensing mode can be used to sense the rotor position and to spin-up with high current.

To sense the rotor position, one of the BEMF sensor outputs (pin SENWIS) will be shared with the voltage comparator that is used for the induction sensing function. Prior to start-up each phase is excited for a short period of time. The current from each coil can be monitored via the multiplexed output (SENWIS). By comparing the rise times of each phase the rotor position can be determined.

In cases where the spindle motor requires more current to spin-up, the sensing mode is used with the exception that the output SENWIS is ignored. The output drivers are operated in saturation in the sensing mode, so the motor current is only limited by the power supply. This condition of induction sense mode can be used to overcome the head friction and must only be used when needed.

#### PWM MODE

The PWM mode is normally used during the start-up phase. Maximum drive voltage is applied to the low drivers to obtain high start-up torque. The purpose of the PWM

mode is to drive the low drivers into saturation, because saturation reduces the power dissipation during start-up.

When the spindle current reaches the value destined by the duty factor of the signal at pin SIPWM, a one-shot is fired. The output of the one-shot remains HIGH for the programmed off-time ( $t_{off}$ ) set by the RC-network at pin SPWMTC. The one-shot is not retriggerable for approximately 10% of the off-time, giving a minimum for the on-time of  $0.1t_{off}$ . During the off-time, the lower spindle output drivers are switched off. The on-time of the drivers is determined by the charging time of the coil current.

The turn-off time follows:  $t_{off} = R \times C \ln(2)$   
With  $R = 68 \text{ k}\Omega$  and  $C = 220 \text{ pF}$ ,  $t_{off} = 10.4 \mu\text{s}$

The minimum on-time is:  $t_{on} = \frac{CV}{I}$

#### LINEAR MODE

The linear mode is used when the motor is near to its intended speed. It can also be used at start-up, but higher power dissipation will occur. In the linear mode the drivers are controlled by a sensing amplifier. A Miller network is used to obtain soft switching on the lower drivers. This prevents large voltage spikes on the motor coils when the lower drivers are switching. The high drivers are switched into the linear (resistive) region.

The transconductance gain of the low driver current to filter voltage can be calculated as follows:

$$G_m = \frac{I_{coil}}{V_{SPWMFLT}} = \frac{1}{R_s} \left\{ \frac{V_{SISENH}}{V_{SPWMFLT}} \right\} = \frac{1}{R_s} = \frac{1}{5} = \text{A/V}$$

For a 100% duty factor at SIPWM, the nominal voltage at SPWMFLT = 1.74 V. The calculated coil current for a 100% duty factor (sense resistors  $R_s = 0.33 \Omega$ ) is:

$$I_{coil} = \frac{1}{0.33} \times \frac{1}{5} \times 1.74 = 1.05 \text{ A}$$

Referencing to the duty factor, the coil current is:

$$I_{coil} = \frac{1}{R_s} = \frac{1}{5} \times 1.74 \times \frac{0\% \text{ duty}}{100} = \frac{1}{R_s} (0.348) \times \frac{0\% \text{ duty}}{100}$$

The duty factor is arranged so that at 100%, the voltage SPWMFLT = 1.74 V and at a 5% duty factor SPWMFLT = 0 V. This is to ensure that at 0% duty factor the current will be zero (allowances for circuit tolerances).

The input decoder is driven by three lines which define the windings to be energized. The input decoder must then translate these lines to six lines to drive the six output drivers. The truth table is given in Table 1. The status of each block in the spindle drive section during the possible modes of operation is given in Table 4



# 12 V Voice Coil Motor (VCM) driver and spindle motor drive combination chip

TDA5147CH

**Table 1** Input decoder truth table for spindle motor drivers

CONDITION	SCNTL1	SCNTL2	SCNTL3	SDRVU <sup>(1)</sup>	SDRVV <sup>(1)</sup>	SDRVW <sup>(1)</sup>
Disable	LOW	LOW	LOW	x	x	x
Dynamic brake	HIGH	HIGH	HIGH	HIGH	HIGH	HIGH
State 1	HIGH	HIGH	LOW	LOW	x	HIGH
State 2	HIGH	LOW	LOW	x	LOW	HIGH
State 3	HIGH	LOW	HIGH	HIGH	LOW	x
State 4	LOW	LOW	HIGH	HIGH	x	LOW
State 5	LOW	HIGH	HIGH	x	HIGH	LOW
State 6	LOW	HIGH	LOW	LOW	HIGH	x
Under voltage	–	–	–	x	x	x

**Note**

1. x = high impedance.

**VCM driver**

The VCM driver (see Fig.1) is a linear, class AB, H-bridge type power driver with all power devices internal to the IC. In addition to the power stage a sense resistor enables the VCM current to be measured. The VCM current is controlled (see Fig.5) via two PWM signals,  $V_{IPWMH}$  and  $V_{IPWML}$ , that are generated by the digital circuit. The signal at pin  $V_{IPWMH}$  weights 32 times more than the signal at pin  $V_{IPWML}$ , thus the current is proportional to the duty factor of  $(V_{IPWML} + 32 \times V_{IPWMH})$ . These PWM signals are filtered by using an internal 3rd-order low-pass filter (Butterworth filter). The bandwidth of this low-pass filter is

nominally 40 kHz (less than 2 degrees lag at 500 Hz), but the real pole may be adjusted by an external capacitor connected to pin  $V_{FLTINP}$ . The filter output (pin  $V_{FLTOUT}$ ) depends on the duty factor of the PWM signals only.

A 3-level mode line ( $V_{PCNTL}$ ) has been included that will:

- Enable VCM drivers;  $V_{PCNTL} = V_{CC5}$  (normal)
- Disable VCM drivers;  $V_{PCNTL} = 0.5V_{CC5}$  or high impedance
- Park (soft retract the actuator);  $V_{PCNTL} = 0 V$ .

See Table 2 for the truth table of the VCM driver modes.

**Table 2**  $V_{PCNTL}$  and SCNTL modes

MODES OF OPERATION AT POWER GOOD (PORN = HIGH)	$V_{PCNTL}$ INPUT STATE <sup>(1)</sup>	SCNTL INPUT STATES <sup>(1)</sup>		
		SCNTL1	SCNTL2	SCNTL3
VCM enable	$V_{CC5}$	X	X	X
VCM disable	$0.5V_{CC5}$ or high impedance	X	X	X
Park	0 V	X	X	X
Spindle enable	X	see Table 3	see Table 3	see Table 3
Spindle disable	X	LOW	LOW	LOW
Spindle brake	X	HIGH	HIGH	HIGH
Spindle mode	$0.5V_{CC5}$ or high impedance	LOW	LOW	LOW

**Note**

1. X = don't care.

# 12 V Voice Coil Motor (VCM) driver and spindle motor drive combination chip

TDA5147CH

### ENABLE VCM DRIVERS

When  $V_{PCNTL}$  equals  $V_{CC5}$ , the VCM drivers are controlled by  $V_{IPWMH}$  and  $V_{IPWML}$ . Their duty factor is converted to a voltage at pin  $V_{FLTOUT}$ . At a 100% duty factor the  $V_{FLTINP}$  voltage is approximately 1 V above  $V_{refout}$ . At a 0% duty factor the  $V_{FLTINP}$  voltage is approximately 1 V below  $V_{refout}$ . At a 50% duty factor, the voltage level is equal to  $V_{refout}$  (typically 4 V). The  $V_{FLTINP}$  voltage is amplified, filtered and output at  $V_{FLTOUT}$ . The voltage at  $V_{FLTOUT}$  varies between  $\pm 2$  V about  $V_{refout}$ . The  $V_{FLTOUT}$  voltage, in conjunction with the sense resistor amplifier, drives the two VCM drivers as illustrated in Fig.4. The equation describing the transconductance from  $V_{FLTINP}$  to  $I_{coil}$  is:

$$G_m = \frac{I_{coil}}{V_{FLTINP} - V_{refout}}$$

$$= \frac{2I_{coil}}{(V_{FLTOUT} - V_{refout})}$$

$$= 2 \times \frac{1}{gain} \times \frac{R2}{R1} \times \frac{1}{RS} \text{ A/V}$$

In a typical application:

$$\frac{I_{coil}}{V_{FLTINP} - V_{refout}} = \frac{2}{4} \times \frac{6.6 \text{ k}\Omega}{10 \text{ k}\Omega} \times \frac{1}{0.33} = 1 \text{ A/V}$$

The transconductance is variable by selecting external resistors  $R2/R1$  and sense resistors  $RS$ .

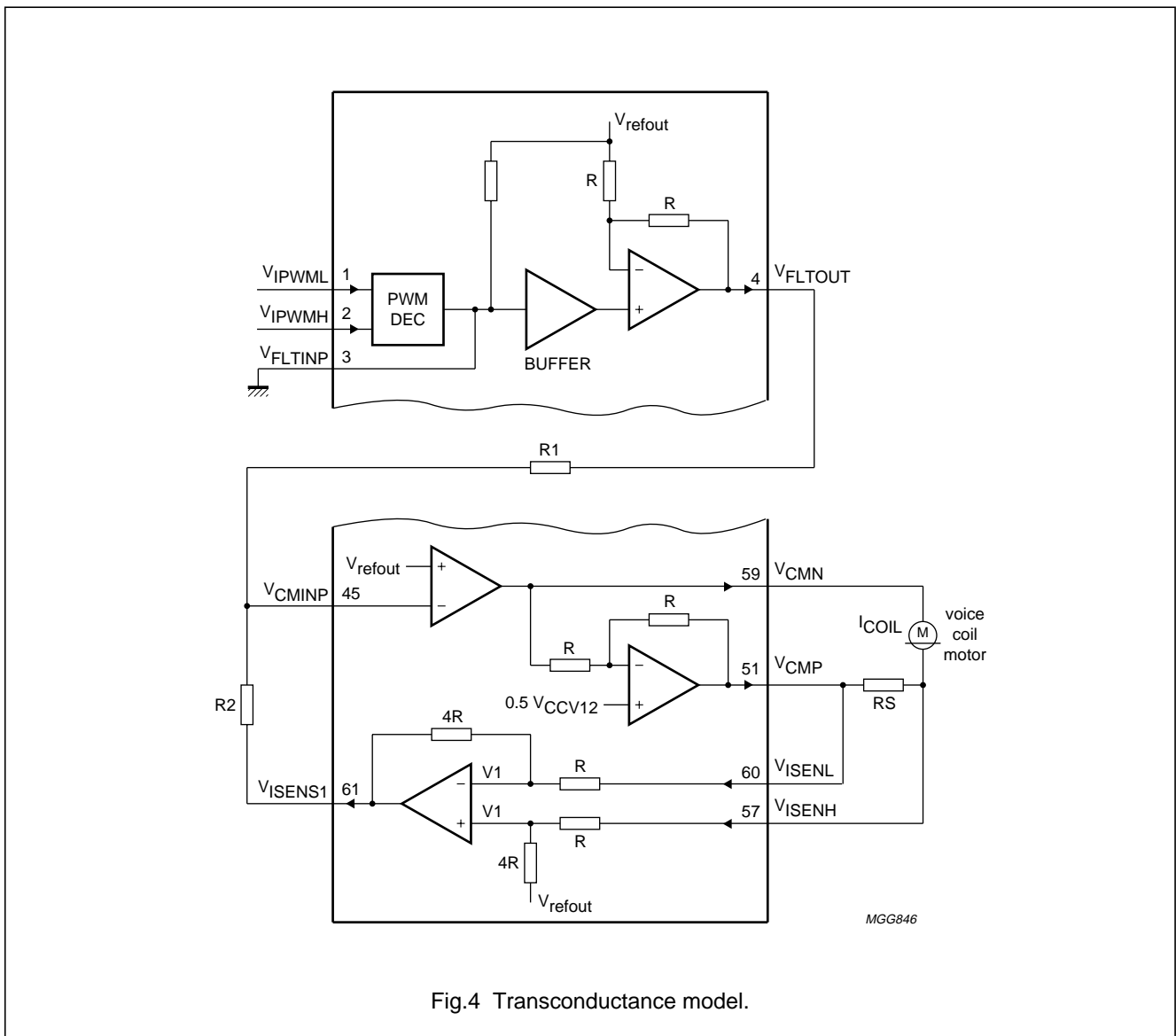

Fig.4 Transconductance model.

# 12 V Voice Coil Motor (VCM) driver and spindle motor drive combination chip

## TDA5147CH

### DISABLE VCM DRIVERS

With the  $V_{PCNTL}$  signal at  $0.5V_{CC}$  the VCM drivers are disabled while the rest of the circuits remain enabled. A sleep mode is initiated when the spindle and VCM are disabled (this places the TDA5147CH in its lowest power setting).

### ACTUATOR PARK

Retracting the actuator can be accomplished by driving  $V_{PCNTL}$  LOW in conjunction with either the spindle turning or a brake voltage has been applied. An adjustable retract voltage of 1.2 V (max.) is applied between the  $V_{CMN}$  and  $V_{CMP}$  outputs. The retract circuit obtains its retract current from the spindle BEMF (pins SHPWR2 and SHPWR3).

The retract voltage is determined by two external resistors. One end is connected to pin  $V_{CMN}$  and the other to ground. The common point is connected to pin  $RET_{ADJ}$  (see Fig.8 for additional information).

The calculation of  $V_{RETRACT}$  is as follows:

$$V_{RETRACT} = V_{BE} \times \left( \frac{R1 + R2}{R1} + \frac{R2}{50 \text{ k}\Omega} \right)$$

$V_{BE} = 0.65 \text{ V}$  at  $25 \text{ }^\circ\text{C}$  and  $\Delta V_{BE}/\Delta T = -2 \text{ mV}/^\circ\text{C}$ ,  $50 \text{ k}\Omega$  can vary by  $\pm 30\%$ . It should be noted that  $R2$  has to be less than  $10 \text{ k}\Omega$ .

Pin  $RET_{ADJ}$  can be pulled to ground by applying  $0.7 \text{ V}$  ( $V_{BE}$ ) on pin BRKTC. This is used to perform spindle brake during power down.

When pin 35 ( $RET_{ADJ}$ ) is pulled to ground, no regulation of the  $V_{CMN}$  is taking place, but the  $V_{CMP}$  output is still kept LOW. In that case, the SHPWR2 and SHPWR3 lines are loaded with the VCM motor by means of an internal MOS transistor.

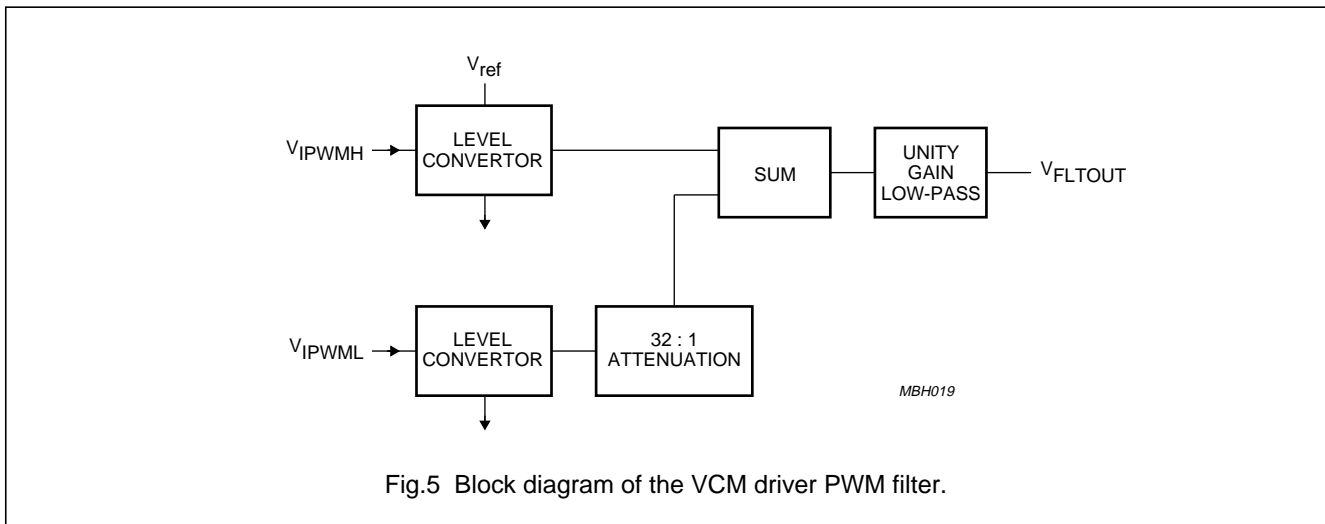

Fig.5 Block diagram of the VCM driver PWM filter.

**Table 3** Booster, spindle drivers, comparator, decoder, amplifier and filter modes

FUNCTION	UPPER BOOSTER	UPPER DRIVERS	LOWER DRIVERS	COMPARATOR	CONTROL AMPLIFIER
Spindle enable	ON	ON	ON	ON	ON
Spindle disable	ON	ON	ON	ON	ON
PORN LOW	OFF	OFF	ON	ON	OFF
Sleep	OFF	OFF	ON	ON	OFF

# 12 V Voice Coil Motor (VCM) driver and spindle motor drive combination chip

## TDA5147CH

### Power-on reset

The Power-on reset circuit monitors the voltage levels of both the +5 V and the +12 V supply voltages as shown in Fig.6. The PORN (active LOW) logic line is set HIGH following a supply voltage rise above a specified voltage threshold plus a hysteresis, and delayed by a time  $t_C$  that is controlled by an external capacitor. This PORN signal should remain HIGH until either the +5 or +12 V supplies drop below the voltage threshold, at which point the PORN line should be asserted LOW.

The  $t_C$  timing is set by the following equation:

$$t_C = \frac{C \times V_{th}}{I}$$

Where  $V_{th} = 2.5 V$  and  $I$  is  $12 \mu A$  (typ.).

A negative going pulse width of  $5 \mu s$  on either the +5 or +12 V rail will provide a full output pulse. If another trigger pulse occurs before the output is completed a new output pulse will be originated. This implies the Power-on reset circuit is a retriggerable one-shot with a maximum trigger pulse of  $5 \mu s$  (see Fig.7).

During a power-down situation the Power-on reset circuit must not only generate a PORN output signal, but must also activate the VCM retract circuitry. In doing so, the VCM driver draws power from SHPWR2 and SHPWR3 during spin-down, and uses this power to bias the VCM against one of the hard stops of the actuator. This prevents the heads from landing on data zones. This BEMF supply is isolated from the supply voltage for the drive, and is half-wave rectified. An external retract capacitor is used to provide the supply voltage for the retract circuit (SHPWR1).

It should be noted that in both power-down retract and command retract situations, the voltage across the VCM can be adjusted (RET<sub>ADJ</sub> pin) to limit the velocity of the actuator.

The status of both the VCM driver blocks and the spindle driver blocks is shown in Tables 5 and 6.

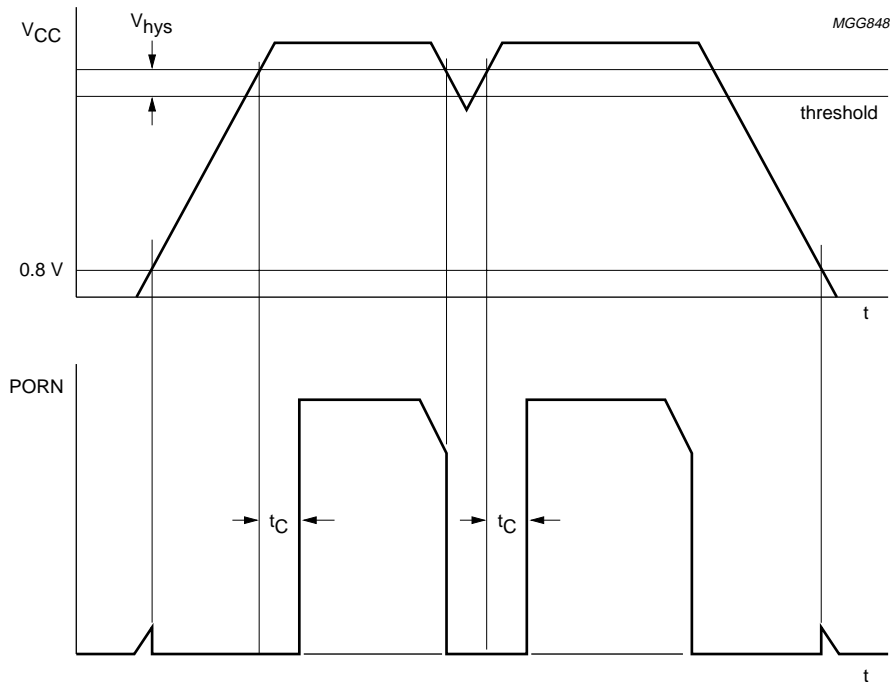

Fig.6 Power-on reset timing.

# 12 V Voice Coil Motor (VCM) driver and spindle motor drive combination chip

## TDA5147CH

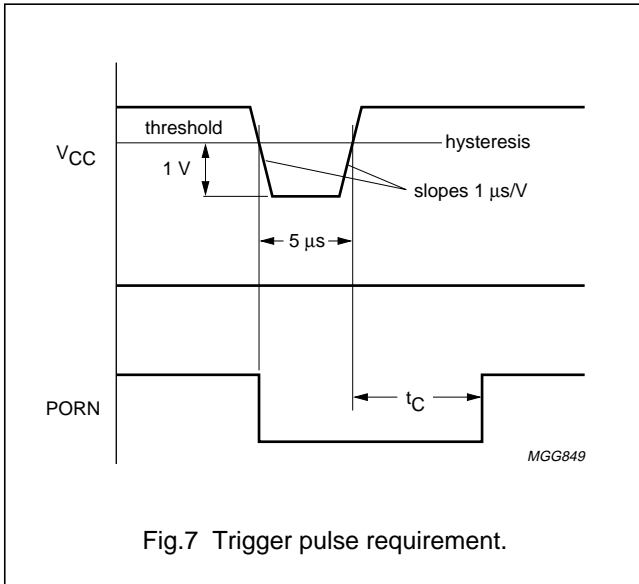

Fig.7 Trigger pulse requirement.

### SLEEP MODE

A sleep mode is used to save power when the spindle drivers and the VCM drivers are in a disabled state. These two conditions automatically turn off all drivers and amplifiers that are not required. The total power dissipation is approximately 100 mW. The sleep mode is activated when both the spindle (SCNTL1, 2 and 3 are LOW) and the VCM are disabled ( $V_{PCNTL}$  left open-circuit).

### THERMAL SHUTDOWN

When the TDA5147CH junction temperature is greater than  $150 \text{ }^\circ\text{C}$  all power drivers will be automatically disabled. This is to ensure that no fire hazard occurs due to chip overheating.

12 V Voice Coil Motor (VCM) driver and spindle motor drive combination chip

TDA5147CH

**Table 4** One-shot, comparators, filter, amplifier and logic decoder modes

FUNCTION	ONE-SHOT	CURRENT COMPARATOR	PWM DECODER FILTER	SMODE COMPARATOR	CURRENT SENSE AMPLIFIER	LOGIC DECODER
Spindle enable	ON	ON	ON	ON	ON	ON
Spindle disable	ON	ON	ON	ON	ON	ON
PORN LOW	ON	ON	ON	ON	OFF	ON
Sleep	ON	ON	ON	ON	OFF	ON

**Table 5**  $V_{ISREF}$ , PWM, power, PORN and retract modes

FUNCTION	$V_{ISREF}$ BUFFER	PWM DECODER	12 V AND 5 V COMPARATOR	FILTER AMPLIFIER	PORN DETECTOR	RETRACT CIRCUIT
VCM enable	ON	ON	ON	ON	ON	OFF
VCM disable	ON	ON	ON	ON	ON	OFF
Park	ON	ON	ON	ON	ON	ON
Sleep	OFF	OFF	ON	OFF	ON	OFF
PORN LOW	OFF	OFF	ON	OFF	ON	ON

**Table 6** Reference, sense, thermal, voltage and sleep modes

FUNCTION	3 LEVEL VOLTAGE	$V_{ref}$ OUTPUT BUFFER	$V_{ref}$ OUTPUT	SENSE2	SENSE1	VCM POWER AMPLIFIER	VOLTAGE GENERATOR	THERMAL SHUTDOWN	SLEEP FUNCTION
VCM enable	ON	ON	ON	ON	ON	ON	ON	ON	OFF
VCM disable	ON	ON	ON	ON	ON	OFF	ON	ON	OFF <sup>(2)</sup>
Park <sup>(1)</sup>	ON	ON	ON	ON	ON	OFF	ON	ON	OFF
Sleep	ON	OFF	OFF	OFF	OFF	OFF	ON	ON	ON <sup>(3)</sup>
PORN LOW	ON	OFF	OFF	OFF	OFF	OFF	ON	ON	ON

**Notes**

1. Park will provide adjustable retract if the spindle brake is on, or if the spindle brake is enabled.
2. If SP disable is OFF.
3. Requires SP disable and VCM disable to be ON.

# 12 V Voice Coil Motor (VCM) driver and spindle motor drive combination chip

## TDA5147CH

### LIMITING VALUES

In accordance with the Absolute Maximum Rating System (IEC 134).

SYMBOL	PARAMETER	CONDITIONS	MIN.	MAX.	UNIT
V <sub>CC5</sub>	analog supply voltage 1	indefinite time period	-0.3	+6.0	V
			-0.3	+7.0	V
V <sub>CCA12</sub>	analog supply voltage 2	indefinite time period	-0.3	+13.5	V
			-0.3	+15.0	V
V <sub>SDRVU</sub> , V <sub>SDRVV</sub> , V <sub>SDRVW</sub> and V <sub>SDRVN</sub>	output voltage spindle motor driver		-0.3	+20	V
V <sub>n</sub>	output voltage on other pins		-0.3	-	V
T <sub>stg</sub>	IC storage temperature		-55	+125	°C
T <sub>j</sub>	maximum junction temperature		-	+150	°C
T <sub>amb</sub>	operating ambient temperature		0	+70	°C

### HANDLING

Inputs and outputs are protected against electrostatic discharge in normal handling. However, to be totally safe, it is desirable to take normal precautions appropriate to handling MOS devices.

### THERMAL CHARACTERISTICS

SYMBOL	PARAMETER	CONDITIONS	VALUE	UNIT
R <sub>th j-a</sub>	thermal resistance from junction to ambient	in free air	28	K/W

# 12 V Voice Coil Motor (VCM) driver and spindle motor drive combination chip

TDA5147CH

## CHARACTERISTICS

### Operating characteristics

 $V_{CC5} = 5\text{ V}; V_{CCS12} = V_{CCA12} = V_{CCV12} = 12\text{ V}; T_{amb} = 0\text{ to }70\text{ }^{\circ}\text{C}.$ 

SYMBOL	PARAMETER	CONDITIONS	MIN.	TYP.	MAX.	UNIT
<b>Supplies</b>						
$V_{CC5}$	analog supply voltage 1		4.5	5	5.5	V
$V_{CCS12}$	supply voltage for spindle motor drivers		10.8	12	13.2	V
$V_{CCV12}$	supply voltage for VCM driver		10.8	12	13.2	V
$V_{CCA12}$	analog supply voltage 2		10.8	12	13.2	V
<b>Upper booster</b>						
$C_{APCP}$	external output capacitor	connected between BSTCP1 and BSTCP2	–	10	–	nF
$C_{CAPFLT}$	charge pump capacitor	connected between BSTFLT and ground	–	22	–	nF
<b>Spindle low side; pin SPWMTC</b>						
$C_{sl}$	capacitor for spindle low side		–	220	–	pF
$R_{sl}$	resistor for spindle low side		–	68	–	k $\Omega$
<b>Capacitors for park voltage supply; pins SHPWR2 and SHPWR3</b>						
$C_{clamp}$	clamp capacitor		–	22	–	$\mu$ F
<b>Digital PWM input; pin SIPWM</b>						
$V_{IH}$	HIGH level input voltage		3	5	5.5	V
$V_{IL}$	LOW level input voltage		–0.3	0	+2	V
<b>Digital inputs of spindle decoder; pins SCNTL1, SCNTL2 and SCNTL3</b>						
$V_{IH}$	HIGH level input voltage	see Table 1; $V_{CC5} = 5\text{ V}$	3.5	–	–	V
<b>3 level input; pin SMODE1</b>						
$V_{oh}$	voltage level for current sense in non PWM mode		$0.75V_{CC5} + 0.15$	–	–	V
$V_{TRI}$	voltage level for BEMF sense and PWM switch control	state also achieved with floating input	$0.25V_{CC5} + 0.15$	$0.50V_{CC5}$	$0.75V_{CC5} - 0.15$	V
$V_{ol}$	voltage level for BEMF sense and linear control		–	–	$0.25V_{CC5} - 0.15$	V
<b>Control amplifier; pin SCOMP</b>						
$C_{SCOMP}$	control loop capacitor		–	47	–	nF
<b>Park enable; pin V<sub>PCNTL</sub></b>						
$V_{oh}$	voltage level for enable		$0.75V_{CC5} + 0.15$	–	–	V
$V_{TRI}$	voltage level for disable	state also achieved with floating input	$0.25V_{CC5} + 0.15$	$0.50V_{CC5}$	$0.75V_{CC5} - 0.15$	V
$V_{ol}$	voltage level for retract		–	–	$0.25V_{CC5} - 0.15$	V



# 12 V Voice Coil Motor (VCM) driver and spindle motor drive combination chip

TDA5147CH

SYMBOL	PARAMETER	CONDITIONS	MIN.	TYP.	MAX.	UNIT
<b>PWM decoder; pins V<sub>IPWML</sub> and V<sub>IPWMH</sub></b>						
V <sub>IH</sub>	HIGH level input voltage		3.0	–	–	V
V <sub>IL</sub>	LOW level input voltage		–	–	2.0	V
f <sub>PWM</sub>	frequency range at the inputs of the PWM	C <sub>FLTINP</sub> = 1.8 nF	–	–	625	kHz
T <sub>PWM</sub>	PWM pulse width		25	–	–	ns
<b>Sense resistor amplifier; pins SISENL and SISENH</b>						
V <sub>CS</sub>	common mode input sense voltage		0	–	2	V
R <sub>SENSE</sub>	spindle sense resistor		–	0.33	–	Ω
<b>Power-on reset generator</b>						
C <sub>PORN</sub>	Power-on reset capacitor	see Fig.6	–	220	–	nF
<b>VCM PWM filter</b>						
C <sub>VFLTINP</sub>	filter capacitor		–	1.8	–	nF
<b>VCM driver</b>						
R <sub>SENSE</sub>	VCM sense resistor		–	0.33	–	Ω

**Electrical characteristics**V<sub>CC5</sub> = 5 V; V<sub>CCS12</sub> = V<sub>CCA2</sub> = V<sub>CCV</sub> = 12 V; T<sub>amb</sub> = 0 to 70 °C.

SYMBOL	PARAMETER	CONDITIONS	MIN.	TYP.	MAX.	UNIT
<b>Analog supply current (nominal voltage)</b>						
I <sub>CC5</sub>	analog supply current 1	linear (no spindle or VCM load)	–	5.0	8.0	mA
		sleep mode (no spindle or VCM load)	–	3.0	–	mA
I <sub>CC12</sub>	analog supply current 2	linear (no spindle or VCM load)	–	15	33	mA
		sleep mode (no spindle or VCM load) sense resistor output	–	2.3	–	mA
		sleep mode (no spindle or VCM load) sense resistor input	–	6.0	–	mA
P <sub>DISS</sub>	total power dissipation	sleep mode	–	–	150	mW
<b>Voltage booster; pin BSTFLT</b>						
V <sub>WCP</sub>	charge pump output voltage	nominal voltages	18.2	19.2	19.8	V
I <sub>CHARGE</sub>	charge pump output current	voltage drop of 100 mV across booster	–	1.5	–	mA

# 12 V Voice Coil Motor (VCM) driver and spindle motor drive combination chip

## TDA5147CH

SYMBOL	PARAMETER	CONDITIONS	MIN.	TYP.	MAX.	UNIT
<b>Power monitor comparators; pins POR5<sub>VADJ</sub> and POR12<sub>VADJ</sub></b>						
V <sub>t12</sub>	threshold voltage level adjustment for +12 V		8.7	9.0	9.3	V
V <sub>t5</sub>	threshold voltage level adjustment for +5 V		4.4	4.5	4.6	V
H <sub>V5</sub>	hysteresis on V <sub>CC5</sub> comparator	hysteresis in positive direction.	30	70	110	mV
H <sub>V12</sub>	hysteresis on V <sub>CCA12</sub> comparator	hysteresis in positive direction.	120	200	280	mV
V <sub>12adj</sub>	Power-on reset 12 V adjustable voltage	normal power supply to resistor divider 25.4 kΩ and 9.7 kΩ	3.25	3.32	3.39	V
V <sub>5adj</sub>	Power-on reset 5 V adjustable voltage	normal power supply to resistor divider 7.86 kΩ and 10 kΩ	2.74	2.8	2.86	V
<b>Power-on reset generator; pins CPOR and PORN</b>						
V <sub>OL</sub>	LOW level input voltage	I <sub>OL</sub> = 2 mA; V <sub>CC</sub> = 5 or 12 V (below threshold voltage)	–	–	0.5	V
V <sub>OH</sub>	HIGH level input voltage	V <sub>CC</sub> = 5 or 12 V (above hysteresis voltage)	4.85	–	–	V
I <sub>CPOR</sub>	source current for charging capacitor		8.2	12	15.3	
V <sub>CPOR</sub>	threshold voltage		–	2.5	–	V
t <sub>dPORN</sub>	Power-on reset delay	capacitance = 220 nF	–	45	–	ms
t <sub>RPULSE</sub>	power supply maximum pulse duration	see Fig.7	–	2.5	5.0	μs
<b>Thermal protection</b>						
T <sub>SOFF</sub>	switch-off junction temperature		150	–	164	°C
ΔT	thermal hysteresis		–	30	–	°C
<b>Thermal warning; pin TEMP</b>						
T <sub>warn</sub>	warning temperature	gives a warning 15 °C before T <sub>SOFF</sub>	–	T <sub>SOFF</sub> – 15	–	°C
V <sub>OL</sub>	output voltage	I <sub>Out</sub> = 500 μA	–	–	1.2	V
I <sub>IH</sub>	leakage current when output collector is 'off'	V <sub>Out</sub> = 5 V	10	–	–	μA

# 12 V Voice Coil Motor (VCM) driver and spindle motor drive combination chip

## TDA5147CH

### Spindle motor driver characteristics

$V_{CC5} = 5\text{ V}$ ;  $V_{CCS12} = V_{CCA12} = V_{CCV12} = 12\text{ V}$ ;  $T_{amb} = 0\text{ to }70\text{ }^{\circ}\text{C}$ .

SYMBOL	PARAMETER	CONDITIONS	MIN.	TYP.	MAX.	UNIT
<b>Overvoltage protection; pins SDRU, SDRV and SDRW</b>						
$V_{CLP}$	overvoltage protection clamping voltage	power supply off; apply voltage to outputs; check clamping voltage is at 100 mA	–	19	–	V
<b>Spindle state control inputs; pins SCNTL1 SCNTL2 and SCNTL3</b>						
$I_{in}$	input current		–10	–	+10	$\mu\text{A}$
<b>Back EMF comparators</b>						
$V_{CM}$	common mode input voltage for centre tap connection (SDRVN)	comparators will be operational with other inputs at $V_{CCA2} - 1\text{ V}$	–0.5	–	$V_{CCA2} + 0.7$	V
$I_{CLP}$	common mode clamping current	$V_{SDRVN}$ at 0 V	–1.6	–	–0.2	mA
$V_{COS}$	comparator offset voltage relative to SDRVN	SDRVN voltage range from 3 to 10 V	–5	–	+5	mV
$\Delta V_{COS}$	variation in comparator voltages	for the same IC	–7	–	+7	mV
$V_{sink}$	comparators output drive sink voltage	$I_{o(sink)} = 1\text{ mA}$	–	–	0.5	V
$V_{source}$	comparators output drive source voltage	$I_{o(source)} = 40\text{ }\mu\text{A}$	2.7	–	–	V
<b>Spindle output drivers; pins SDRVU, SDRVV and SDRVW</b>						
$R_{ds(on)}$	total resistance at output (source + sink + isolation)	$I_{SDRV} = 1\text{ A}$ at $T_{amb} = 25\text{ }^{\circ}\text{C}$	–	0.8	1.0	$\Omega$
		$I_{SDRV} = 1\text{ A}$ at $T_j = 125\text{ }^{\circ}\text{C}$	–	1.3	1.7	$\Omega$
$I_{DSX}$	off-state output leakage current	disable state $T_j = 125\text{ }^{\circ}\text{C}$	–	0.3	1.0	mA
$L_{IN}$	recirculating diode forward voltage	$I_{SDRV} = 1\text{ A}$	–	0.8	1.1	V
SRT	slew rate test	test for Miller network	0.11	–	0.27	$\text{V}/\mu\text{s}$
<b>Spindle current control PWM DAC and filter; pins SIPWM and SPWMFLT</b>						
$L_{IN}$	input current at SIPWM	at HIGH-to-LOW voltage transition	–200	–	+200	mA
$R_{SOUT}$	output resistance at SPWMFLT		23	34	45	$\text{K}\Omega$
$V_{SOUT}$	SPWMFLT voltage	100% duty factor SIPWM	–	1.75	–	V
		50% duty factor at SIPWM	–	0.85	–	V
		0% duty factor at SIPWM	–	0	–	V

# 12 V Voice Coil Motor (VCM) driver and spindle motor drive combination chip

TDA5147CH

SYMBOL	PARAMETER	CONDITIONS	MIN.	TYP.	MAX.	UNIT
<b>PWM one-shot; pin SPWMTC</b>						
$I_{sk}$	output sink current	$V_o = 3\text{ V}$	600	850	1100	$\mu\text{A}$
$I_{sc}$	output source current	$V_o = 1\text{ V}$	–	–12	–	$\mu\text{A}$
$V_{thST}$	threshold voltage start level	voltage for discharging	2.0	2.56	3.0	V
$V_{thEND}$	threshold voltage end level	voltage for charging	0	0.1	0.2	V
$t_{OFF}$	one-shot off time	external network of $R = 68\text{ k}\Omega$ and $C = 220\text{ pF}$	8	10	12	$\mu\text{s}$
$t_{ON(min)}$	one-shot minimum on time	external network of $R = 68\text{ k}\Omega$ and $C = 220\text{ pF}$	1	–	–	$\mu\text{s}$
<b>Current control loop and sense amplifier; pins SISENH and SCOMP</b>						
$V_i$	current sense amplifier common mode input voltage	current sense amplifier operational over range	0	–	3.0	V
$I_{SENSE}$	current sense amplifier input current		–10	–	–	$\mu\text{A}$
$K_{SP}$	voltage ratio between SPWMFLT and SISENH	over sense resistance = $0.1$ to $1\ \Omega$	4.9	5.0	5.1	V/V
$V_{SENSEH}$	output voltage at SENSEH	for 100% duty factor; $R_s = 0.33\ \Omega$	0.324	0.342	0.36	V
		for 50% duty factor; $R_s = 0.33\ \Omega$	–	0.174	–	V
		for 5% duty factor; $R_s = 0.33\ \Omega$	0	0.018	0.026	V
		for 0% duty factor; $R_s = 0.33\ \Omega$	0	0	1.0	mV
$B_{WD}$	current loop bandwidth for SPWMFLT to motor current	$R_s = 0.33\ \Omega$ , $L_{motor} = 1\text{ mH}$ , $R_{motor} = 12.0\ \Omega$	3	5	–	kHz

# 12 V Voice Coil Motor (VCM) driver and spindle motor drive combination chip

TDA5147CH

## Voice coil motor driver characteristics

 $V_{CC5} = 5\text{ V}; V_{CCS12} = V_{CCA12} = V_{CCV12} = 12\text{ V}; T_{amb} = 0\text{ to }70\text{ }^{\circ}\text{C}.$ 

SYMBOL	PARAMETER	CONDITIONS	MIN.	TYP.	MAX.	UNIT
<b>Retract control voltage; pins <math>V_{CMN}</math> and <math>V_{CMP}</math></b>						
$I_{RET}$	retract voltage load current	$V_{SHPWR1} = 9\text{ V}$ ; power supplies off	–	3.0	–	$\mu\text{A}$
$t_{RET}$	retract voltage hold time (power down)	retract capacitor = $2.2\text{ }\mu\text{F}$	5	–	–	s
$V_{RET}$	retract voltage regulation	nominal power supply at $T_{amb} = 25\text{ }^{\circ}\text{C}$ , pin 35 open	0.8	1.1	1.4	V
		power supply off; $V_{SDRVU} = 9\text{ to }2\text{ V}$ ; $V_{SHPWR1} = 7.5\text{ V}$ , pin 35 open	0.8	1.1	1.4	V
$I_{BRAKE}$	$I_{BRK1}$	power supply off; $SHPWR1 = 8\text{ V}$ ; $SHPWR2, 3 = 4\text{ V}$ ; $RET_{ADJ} = 0\text{ V}$ ; $R_{LOAD(VCM)} = 10\text{ }\Omega$	120	–	–	mA
	$I_{BRK2}$	power supply off; $SHPWR1 = 6.5\text{ V}$ ; $SHPWR2, 3 = 2\text{ V}$ ; $RET_{ADJ} = 0\text{ V}$ ; $R_{LOAD(VCM)} = 10\text{ }\Omega$	50	–	–	mA
<b>VCM current control PWM DAC; pins <math>V_{IPWMH}</math>, <math>V_{IPWML}</math> and <math>V_{FLTINP}</math></b>						
$I_{LIN}$	input current $V_{IPWMH}, V_{IPWML}$	voltage range 0 to 5 V	–200	–	+200	$\mu\text{A}$
$V_{FL(p)}$	positive full-scale DAC output voltage $V_{FLTINP} - V_{refout}$	100% duty factor	–	+1.0	–	V
$V_{FL(n)}$	negative full-scale DAC output voltage $V_{FLTINP} - V_{refout}$	0% duty factor	–	–1.0	–	V
	current ratio between MSB and LSB		31.5	32	32.5	
$Z_O$	output impedance from $V_{FLTINP}$ to $V_{refout}$		1.40	2.0	2.6	$\text{k}\Omega$

# 12 V Voice Coil Motor (VCM) driver and spindle motor drive combination chip

TDA5147CH

SYMBOL	PARAMETER	CONDITIONS	MIN.	TYP.	MAX.	UNIT
<b>VCM PWM filter; pins V<sub>FLTINP</sub> and V<sub>FLTOUT</sub></b>						
I <sub>o(VFLTOUT)</sub>	output current on V <sub>FLTOUT</sub>	V <sub>FLTOUT</sub> = ΔV <sub>o</sub> + 10 mV	500	–	–	μA
ΔΦ	maximum phase shift from V <sub>FLTINP</sub> to V <sub>FLTOUT</sub>	measured at 500 Hz; C <sub>filter</sub> = 1.8 nF	–	–	2	deg
f <sub>co</sub>	filter cut-off frequency from V <sub>FLTINP</sub> to V <sub>FLTOUT</sub>		–	40	–	kHz
att	filter attenuation at 1 MHz measured from V <sub>FLTINP</sub> to V <sub>FLTOUT</sub>		–	70	–	dB
V <sub>FLTOUT</sub>	output voltage range measured at V <sub>FLTOUT</sub> , with V <sub>IPWML</sub> and V <sub>IPWMH</sub>	0% duty factor	V – 2.08	V – 2.0	V – 1.92	V
		50% duty factor	V – 0.06	V	V + 0.06	V
		100% duty factor	V + 1.92	V + 2	V + 2.08	V
<b>Reference voltage; pin V<sub>refout</sub></b>						
V <sub>ref(o)</sub>	output reference voltage	I <sub>o</sub> = 4 mA; C <sub>L</sub> = 10 nF	3.8	4.0	4.2	V
<b>Current Sense Amplifier; pins V<sub>ISENS1</sub>, V<sub>ISENL</sub> and V<sub>ISENH</sub></b>						
I <sub>SEN</sub>	input current at V <sub>ISENL</sub> , V <sub>ISENH</sub>	overvoltage range of 0 to 12 V	–200	+415	+540	μA
I <sub>sk1</sub>	output sink current 1 V <sub>ISENS1</sub>	force V <sub>ISENH</sub> - V <sub>ISENL</sub> to equal –250 mV; allow output drop of 100 mV between no load and full load	400	–	–	μA
I <sub>s1</sub>	output source current 1 V <sub>ISENL</sub>	force V <sub>ISENH</sub> - V <sub>ISENL</sub> to equal 250 mV; allow output drop of 100 mV between no load and full load	400	–	–	μA
V <sub>R1</sub>	operating voltage range V <sub>ISENL</sub> , V <sub>ISENH</sub>	gain and offset valid	0	–	12	V
G1	amplifier gain for $\frac{V_{ISENS1} - V_{refout}}{V_{ISENS1} - V_{ISENL}}$	under all conditions	3.8	4.0	4.2	
V <sub>os1</sub>	output offset voltage	V <sub>ISENH</sub> - V <sub>ISENL</sub> = 0 V at 0.5V <sub>CC</sub>	–15	–	+15	mV
B <sub>W1</sub>	unity gain bandwidth		–	10	–	MHz
PSRR	power supply rejection ratio	f <sub>i</sub> < 20 kHz	–	60	–	dB
<b>Brake after park function; pins BRKTC and RET<sub>ADJ</sub></b>						
V <sub>BRAKE</sub>	BRKTC level to perform brake action		0.4	0.7		V
I <sub>BRKTCON</sub>	BRKTC input current during power 'on'	V <sub>BRKTC</sub> = 0.4 V	300	–	–	μA
I <sub>RETADJON</sub>	RET <sub>ADJ</sub> current during power 'on'	V <sub>RETADJ</sub> = 0.4 V	–	–	10	μA
V <sub>RETADJOFF</sub>	low level output voltage on RET <sub>ADJ</sub> power 'OFF'	V <sub>CC5</sub> = 0 V; SHPWR2 = 5 V; V <sub>CC12</sub> = 0 V; I <sub>RETADJ</sub> = 400 μA	–	–	0.5	V

# 12 V Voice Coil Motor (VCM) driver and spindle motor drive combination chip

TDA5147CH

SYMBOL	PARAMETER	CONDITIONS	MIN.	TYP.	MAX.	UNIT
<b>VCM output drivers; pins <math>V_{CMP}</math>, <math>V_{CMN}</math> and <math>V_{CMINP}</math></b>						
$R_{DSON25}$	total output resistance (source + sink + isolation)	$T_{amb} = 25\text{ }^{\circ}\text{C}$	–	1.0	1.25	$\Omega$
$R_{DSON125}$		$T_j = 125\text{ }^{\circ}\text{C}$	–	1.5	1.9	$\Omega$
$I_{LK}$	output leakage current	$T_j = 125\text{ }^{\circ}\text{C}$	–	–	1	mA
$B_W$	unity gain bandwidth	from $V_{CMINP}$ to $V_{CMP}$ , $V_{CMN}$	–	2	–	MHz
$t_{cro}$	crossover distortion time	ramp input $V_{CMINP} = 20\text{ }\mu\text{s}$	–	2	5	$\mu\text{s}$
$RATIO = \frac{I_2}{I_1}$	symmetry of VCM drivers $V_{CMP}$ , $V_{CMN}$	$I_2 = I_{RVCM}$ at duty factor = 10%; $I_1 = I_{RCVM}$ at duty factor = 90%; $R_S = 0.33\text{ }\Omega$ ; $R_1 = 10\text{ k}\Omega$ , $R_2 = 6.6\text{ k}\Omega$ , $R_L = 15\text{ }\Omega$	0.93	1	1.07	
$L = \frac{I_2 - I_1}{I_1 - I_0}$	linearity of VCM drivers $V_{CMP}$ , $V_{CMN}$	$I_2 = I_{RVCM}$ at duty factor = 10%; $I_1 = I_{RCVM}$ at duty factor = 90%; $I_0 = I_{RCVM}$ at duty factor = 50%; $R_S = 0.33\text{ }\Omega$ ; $R_1 = 10\text{ k}\Omega$ , $R_2 = 6.6\text{ k}\Omega$ , $R_L = 15\text{ }\Omega$	0.97	1	1.07	
$I_{os}$	VCM output offset current	$V_{IPWMH}$ , $V_{IPWML}$ at 50% duty factor; $R_S = 0.33\text{ }\Omega$ ; $R_L = 15\text{ }\Omega$ ; $R_1 = 10\text{ k}\Omega$ , $R_2 = 6.6\text{ k}\Omega$	–28	0	+28	mA
$I_{IND}$	input current $V_{CMINP}$	$V_i = 0$ to 10 V	–	0.07	0.2	$\mu\text{A}$
$V_{OS1}$	input offset voltage $V_{CMINP}$	from $V_{CMINP}$ to $V_{refout}$	–10	–	+10	mV

**Notes**

- $V_{CCA12}$ ,  $V_{CCV12}$ ,  $V_{CCS12}$  and  $V_{CC5}$  are connected together; the outputs SDRVU, SDRVV, SDRVW,  $V_{CMP}$  and  $V_{CMN}$  are not loaded. Sleep mode defined by 000 as spindle code and VCM disable.
- Switching levels with respect to SDRVU, SDRVV and SDRVW.
- For the description of the Power-on reset see Fig.6.
- On spindle motor drivers:
  - Zero duty factor guarantees zero current output.
  - 5% duty factor guarantees current output.
  - Maximum current will be activated at 100% duty factor.
- $0.2\text{ V} < V_{SDRVN} < V_{CCA12} - 1\text{ V}$ .

## 12 V Voice Coil Motor (VCM) driver and spindle motor drive combination chip

TDA5147CH

### EQUATIONS

Gain from  $V_{FLTINP}$  to  $V_{FLTOUT}$ :

$$\frac{V_{FLTOUT} - V_{refout}}{V_{FLTINP} - V_{refout}} = 2 \quad (1)$$

Gain from  $V_{FLTOUT}$  to  $V_{ISENS1}$  (under closed loop  $V_{CMINP} = V_{refout}$ ):

$$\frac{V_{FLTOUT} - V_{refout}}{R1} = \frac{V_{ISENS1} - V_{refout}}{R2} \text{ or } \frac{V_{FLTOUT} - V_{refout}}{V_{SENS1} - V_{refout}} = \frac{R1}{R2} \quad (2)$$

Gain of  $V_{ISENS1}$  relative to  $\Delta V_s$  (voltage across  $R_s$ ):

$$\text{HAVE } \frac{V1 - V_{refout}}{4R} = \frac{V_{ISENH}}{R} \quad \frac{V1 - V_{SENS1}}{4R} = \frac{V_{ISENL}}{R} \quad (3)$$

$$\text{SUB } \frac{1 - V_{refout}}{4R} = \frac{V_{ISENL} - V_{ISENH}}{R} = \frac{\Delta V_s}{R} \text{ or } \frac{V_{SENS1} - V_{refout}}{\Delta V_s} = 4 \quad (4)$$

Transconductance equation:

$$G_m = \frac{I_{coil}}{V_{FLTINP} - V_{refout}} = \frac{\Delta V_s}{R_s} \times \frac{1}{V_{FLTINP} - V_{refout}} \quad (5)$$

$$\text{From equation (1): } G_m = \frac{\Delta V_s}{R_s} \times \frac{2}{V_{FLTOUT} - V_{refout}}$$

$$\text{From equation (2): } G_m = \frac{\Delta V_s}{R_s} \times 2 \times \frac{R2}{R1} (V_{SENS1} - V_{refout})$$

$$\text{From equation (3) and (4): } G_m = \frac{1}{R_s} \times \frac{1}{4} \times 2 \times \frac{R2}{R1} = \frac{1}{2} \times \frac{1}{R_s} \times \frac{R2}{R1}$$



# 12 V Voice Coil Motor (VCM) driver and spindle motor drive combination chip

## TDA5147CH

### APPLICATION INFORMATION

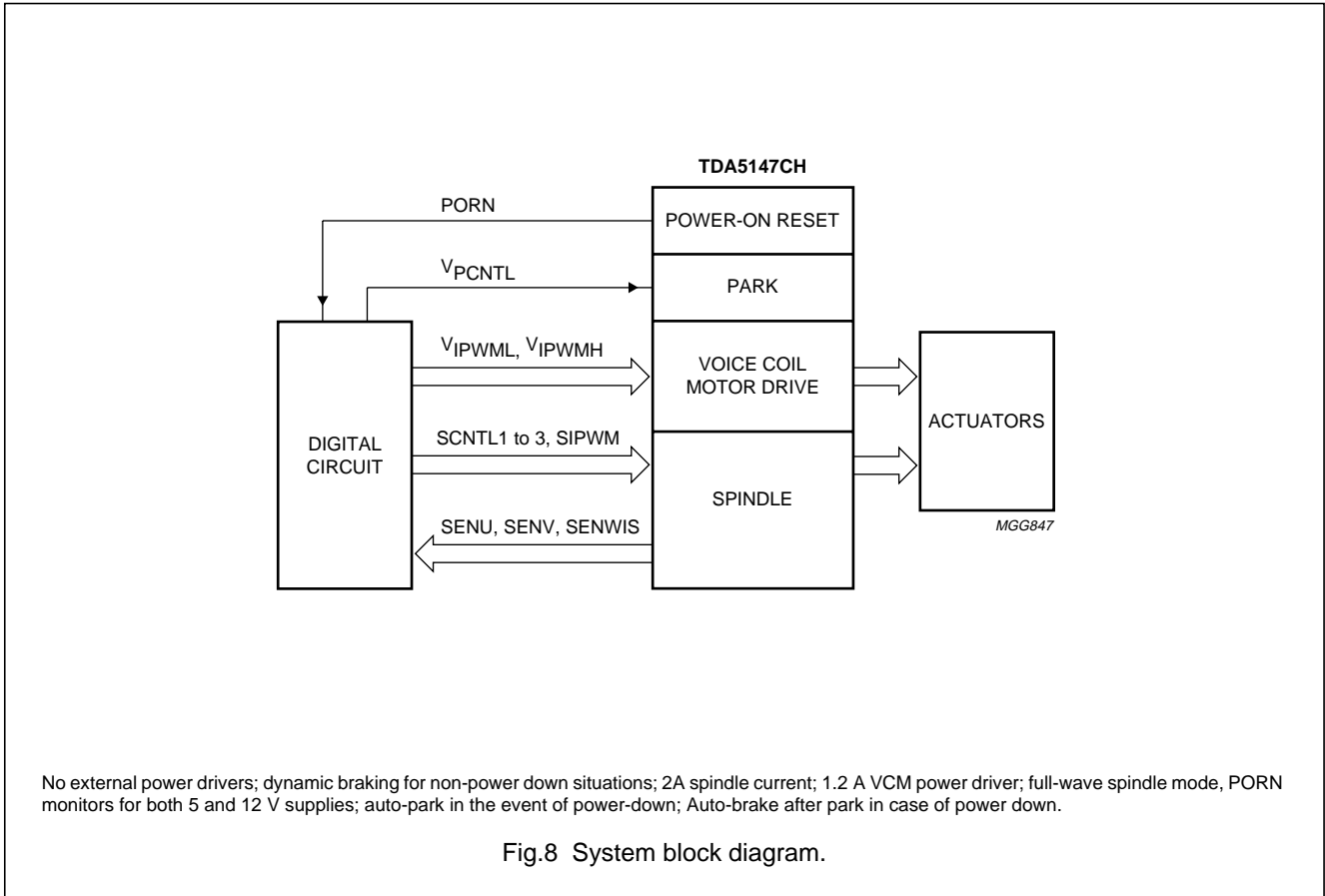

# 12 V Voice Coil Motor (VCM) driver and spindle motor drive combination chip

## TDA5147CH

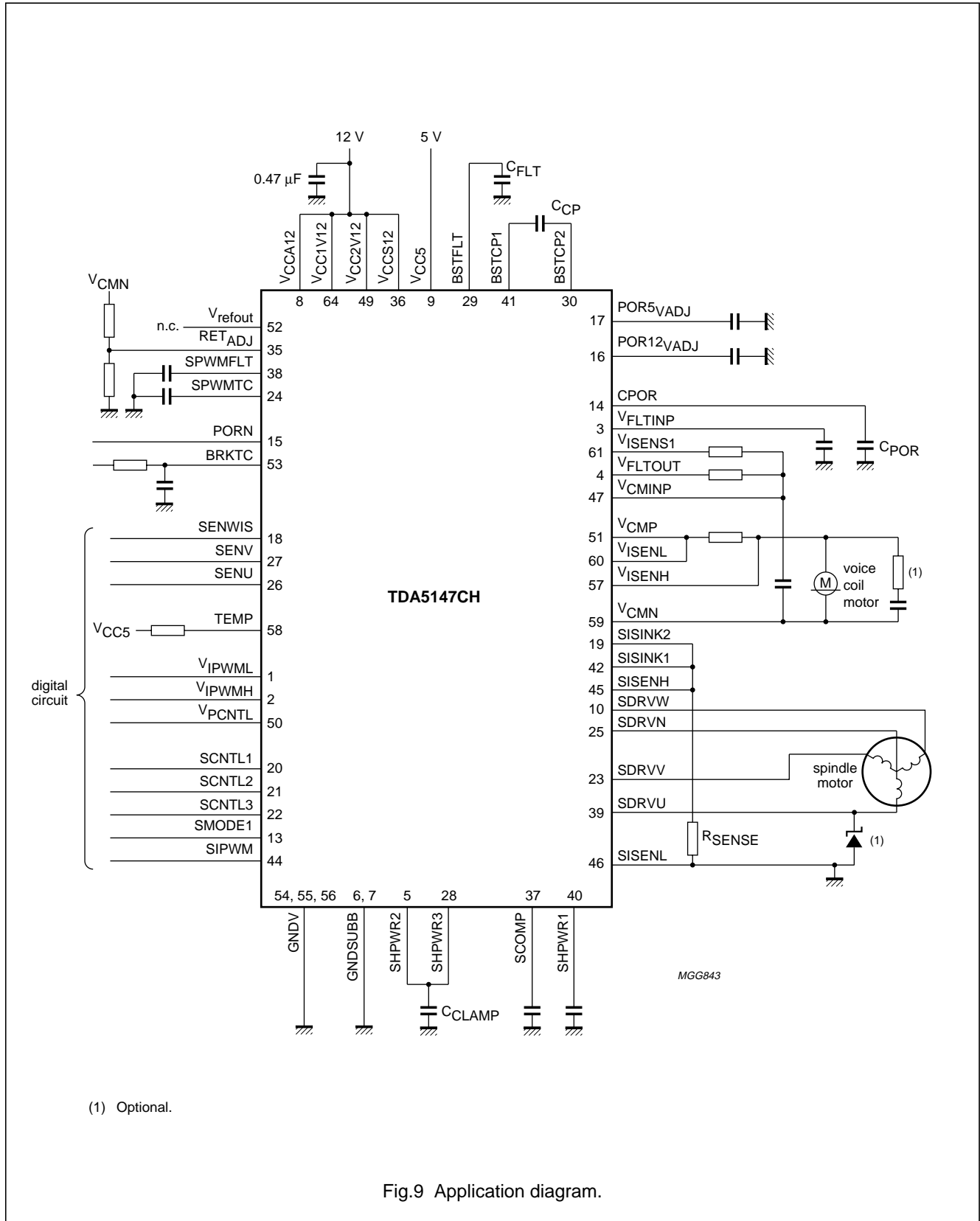

# 12 V Voice Coil Motor (VCM) driver and spindle motor drive combination chip

TDA5147CH

## PACKAGE OUTLINE

QFP64: plastic quad flat package; 64 leads (lead length 1.6 mm); body 14 x 14 x 2.7 mm

SOT393-1

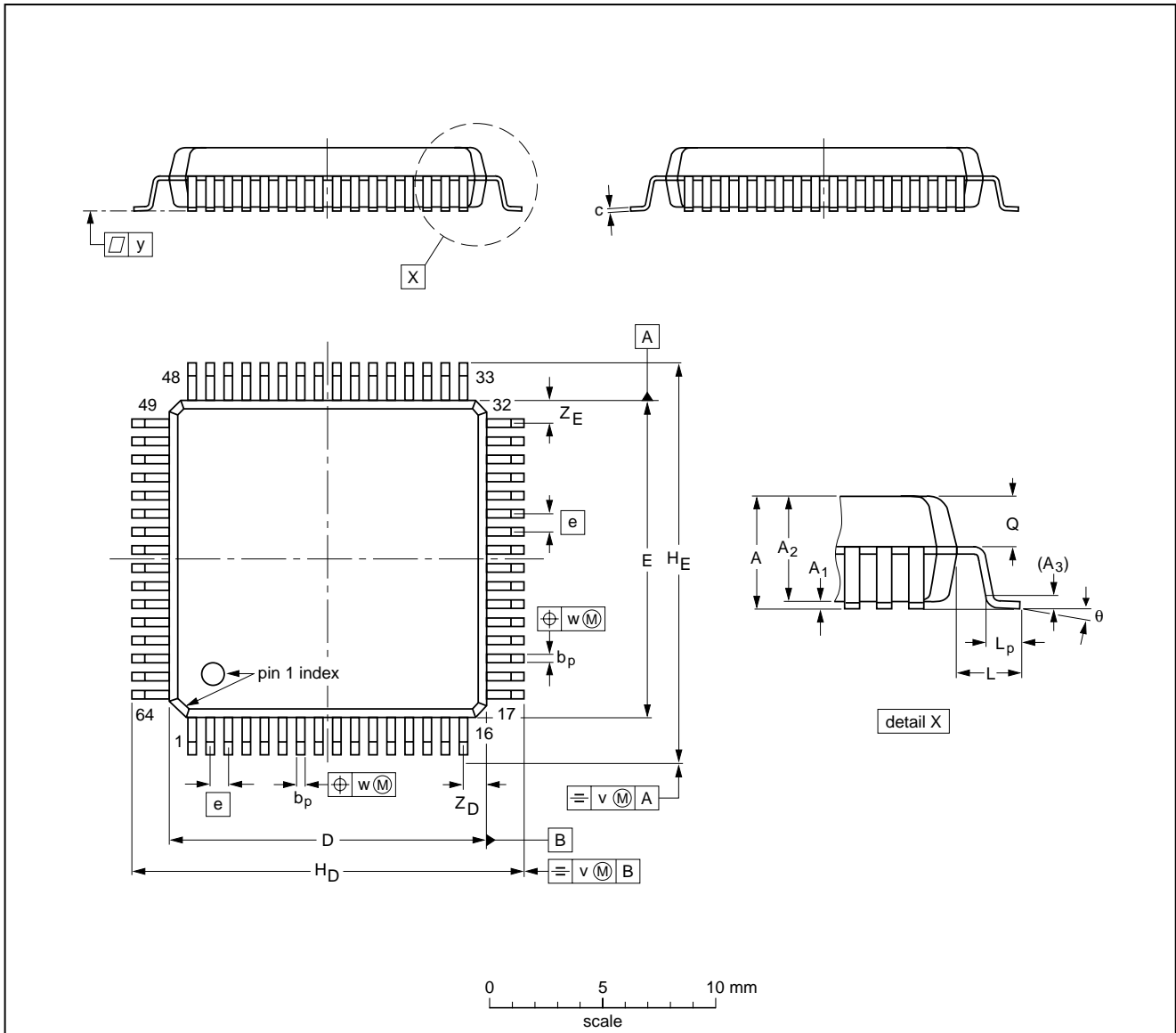

**DIMENSIONS (mm are the original dimensions)**

UNIT	A max.	A <sub>1</sub>	A <sub>2</sub>	A <sub>3</sub>	b <sub>p</sub>	c	D <sup>(1)</sup>	E <sup>(1)</sup>	e	H <sub>D</sub>	H <sub>E</sub>	L	L <sub>p</sub>	Q	v	w	y	Z <sub>D</sub> <sup>(1)</sup>	Z <sub>E</sub> <sup>(1)</sup>	θ
mm	3.00	0.25 0.10	2.75 2.55	0.25	0.45 0.30	0.23 0.13	14.1 13.9	14.1 13.9	0.8	17.45 16.95	17.45 16.95	1.60	1.03 0.73	1.4 1.1	0.16	0.16	0.10	1.2 0.8	1.2 0.8	7° 0°

**Note**

1. Plastic or metal protrusions of 0.25 mm maximum per side are not included.

OUTLINE VERSION	REFERENCES				EUROPEAN PROJECTION	ISSUE DATE
	IEC	JEDEC	EIAJ			
SOT393-1		MS-022				94-06-22- 96-05-21

## 12 V Voice Coil Motor (VCM) driver and spindle motor drive combination chip

TDA5147CH

### SOLDERING

#### Introduction

There is no soldering method that is ideal for all IC packages. Wave soldering is often preferred when through-hole and surface mounted components are mixed on one printed-circuit board. However, wave soldering is not always suitable for surface mounted ICs, or for printed-circuits with high population densities. In these situations reflow soldering is often used.

This text gives a very brief insight to a complex technology. A more in-depth account of soldering ICs can be found in our *"IC Package Databook"* (order code 9398 652 90011).

#### Reflow soldering

Reflow soldering techniques are suitable for all QFP packages.

The choice of heating method may be influenced by larger plastic QFP packages (44 leads, or more). If infrared or vapour phase heating is used and the large packages are not absolutely dry (less than 0.1% moisture content by weight), vaporization of the small amount of moisture in them can cause cracking of the plastic body. For more information, refer to the Drypack chapter in our *"Quality Reference Handbook"* (order code 9397 750 00192).

Reflow soldering requires solder paste (a suspension of fine solder particles, flux and binding agent) to be applied to the printed-circuit board by screen printing, stencilling or pressure-syringe dispensing before package placement.

Several techniques exist for reflowing; for example, thermal conduction by heated belt. Dwell times vary between 50 and 300 seconds depending on heating method. Typical reflow temperatures range from 215 to 250 °C.

Preheating is necessary to dry the paste and evaporate the binding agent. Preheating duration: 45 minutes at 45 °C.

#### Wave soldering

Wave soldering is **not** recommended for QFP packages. This is because of the likelihood of solder bridging due to closely-spaced leads and the possibility of incomplete solder penetration in multi-lead devices.

If wave soldering cannot be avoided, the following conditions must be observed:

- **A double-wave (a turbulent wave with high upward pressure followed by a smooth laminar wave) soldering technique should be used.**
- **The footprint must be at an angle of 45° to the board direction and must incorporate solder thieves downstream and at the side corners.**

**Even with these conditions, do not consider wave soldering the following packages: QFP52 (SOT379-1), QFP100 (SOT317-1), QFP100 (SOT317-2), QFP100 (SOT382-1) or QFP160 (SOT322-1).**

During placement and before soldering, the package must be fixed with a droplet of adhesive. The adhesive can be applied by screen printing, pin transfer or syringe dispensing. The package can be soldered after the adhesive is cured.

Maximum permissible solder temperature is 260 °C, and maximum duration of package immersion in solder is 10 seconds, if cooled to less than 150 °C within 6 seconds. Typical dwell time is 4 seconds at 250 °C.

A mildly-activated flux will eliminate the need for removal of corrosive residues in most applications.

#### Repairing soldered joints

Fix the component by first soldering two diagonally-opposite end leads. Use only a low voltage soldering iron (less than 24 V) applied to the flat part of the lead. Contact time must be limited to 10 seconds at up to 300 °C. When using a dedicated tool, all other leads can be soldered in one operation within 2 to 5 seconds between 270 and 320 °C.

# 12 V Voice Coil Motor (VCM) driver and spindle motor drive combination chip

TDA5147CH

## DEFINITIONS

<b>Data sheet status</b>	
Objective specification	This data sheet contains target or goal specifications for product development.
Preliminary specification	This data sheet contains preliminary data; supplementary data may be published later.
Product specification	This data sheet contains final product specifications.
<b>Limiting values</b>	
Limiting values given are in accordance with the Absolute Maximum Rating System (IEC 134). Stress above one or more of the limiting values may cause permanent damage to the device. These are stress ratings only and operation of the device at these or at any other conditions above those given in the Characteristics sections of the specification is not implied. Exposure to limiting values for extended periods may affect device reliability.	
<b>Application information</b>	
Where application information is given, it is advisory and does not form part of the specification.	

## LIFE SUPPORT APPLICATIONS

These products are not designed for use in life support appliances, devices, or systems where malfunction of these products can reasonably be expected to result in personal injury. Philips customers using or selling these products for use in such applications do so at their own risk and agree to fully indemnify Philips for any damages resulting from such improper use or sale.

---

12 V Voice Coil Motor (VCM) driver and  
spindle motor drive combination chip

---

TDA5147CH

**NOTES**

---

12 V Voice Coil Motor (VCM) driver and  
spindle motor drive combination chip

---

TDA5147CH

**NOTES**

# Philips Semiconductors – a worldwide company

**Argentina:** see South America

**Australia:** 34 Waterloo Road, NORTH RYDE, NSW 2113,  
Tel. +61 2 9805 4455, Fax. +61 2 9805 4466

**Austria:** Computerstr. 6, A-1101 WIEN, P.O. Box 213, Tel. +43 160 1010,  
Fax. +43 160 101 1210

**Belarus:** Hotel Minsk Business Center, Bld. 3, r. 1211, Volodarski Str. 6,  
220050 MINSK, Tel. +375 172 200 733, Fax. +375 172 200 773

**Belgium:** see The Netherlands

**Brazil:** see South America

**Bulgaria:** Philips Bulgaria Ltd., Energoproject, 15th floor,  
51 James Bourchier Blvd., 1407 SOFIA,  
Tel. +359 2 689 211, Fax. +359 2 689 102

**Canada:** PHILIPS SEMICONDUCTORS/COMPONENTS,  
Tel. +1 800 234 7381

**China/Hong Kong:** 501 Hong Kong Industrial Technology Centre,  
72 Tat Chee Avenue, Kowloon Tong, HONG KONG,  
Tel. +852 2319 7888, Fax. +852 2319 7700

**Colombia:** see South America

**Czech Republic:** see Austria

**Denmark:** Prags Boulevard 80, PB 1919, DK-2300 COPENHAGEN S,  
Tel. +45 32 88 2636, Fax. +45 31 57 0044

**Finland:** Sinikalliontie 3, FIN-02630 ESPOO,  
Tel. +358 9 615800, Fax. +358 9 61580920

**France:** 4 Rue du Port-aux-Vins, BP317, 92156 SURESNES Cedex,  
Tel. +33 1 40 99 6161, Fax. +33 1 40 99 6427

**Germany:** Hammerbrookstraße 69, D-20097 HAMBURG,  
Tel. +49 40 23 53 60, Fax. +49 40 23 536 300

**Greece:** No. 15, 25th March Street, GR 17778 TAVROS/ATHENS,  
Tel. +30 1 4894 339/239, Fax. +30 1 4814 240

**Hungary:** see Austria

**India:** Philips INDIA Ltd, Band Box Building, 2nd floor,  
254-D, Dr. Annie Besant Road, Worli, MUMBAI 400 025,  
Tel. +91 22 493 8541, Fax. +91 22 493 0966

**Indonesia:** see Singapore

**Ireland:** Newstead, Clonskeagh, DUBLIN 14,  
Tel. +353 1 7640 000, Fax. +353 1 7640 200

**Israel:** RAPAC Electronics, 7 Kehilat Saloniki St, PO Box 18053,  
TEL AVIV 61180, Tel. +972 3 645 0444, Fax. +972 3 649 1007

**Italy:** PHILIPS SEMICONDUCTORS, Piazza IV Novembre 3,  
20124 MILANO, Tel. +39 2 6752 2531, Fax. +39 2 6752 2557

**Japan:** Philips Bldg 13-37, Kohnan 2-chome, Minato-ku, TOKYO 108,  
Tel. +81 3 3740 5130, Fax. +81 3 3740 5077

**Korea:** Philips House, 260-199 Itaewon-dong, Yongsan-ku, SEOUL,  
Tel. +82 2 709 1412, Fax. +82 2 709 1415

**Malaysia:** No. 76 Jalan Universiti, 46200 PETALING JAYA, SELANGOR,  
Tel. +60 3 750 5214, Fax. +60 3 757 4880

**Mexico:** 5900 Gateway East, Suite 200, EL PASO, TEXAS 79905,  
Tel. +9-5 800 234 7381

**Middle East:** see Italy

**Netherlands:** Postbus 90050, 5600 PB EINDHOVEN, Bldg. VB,  
Tel. +31 40 27 82785, Fax. +31 40 27 88399

**New Zealand:** 2 Wagener Place, C.P.O. Box 1041, AUCKLAND,  
Tel. +64 9 849 4160, Fax. +64 9 849 7811

**Norway:** Box 1, Manglerud 0612, OSLO,  
Tel. +47 22 74 8000, Fax. +47 22 74 8341

**Philippines:** Philips Semiconductors Philippines Inc.,  
106 Valero St. Salcedo Village, P.O. Box 2108 MCC, MAKATI,  
Metro MANILA, Tel. +63 2 816 6380, Fax. +63 2 817 3474

**Poland:** Ul. Lukiska 10, PL 04-123 WARSZAWA,  
Tel. +48 22 612 2831, Fax. +48 22 612 2327

**Portugal:** see Spain

**Romania:** see Italy

**Russia:** Philips Russia, Ul. Usatcheva 35A, 119048 MOSCOW,  
Tel. +7 095 755 6918, Fax. +7 095 755 6919

**Singapore:** Lorong 1, Toa Payoh, SINGAPORE 1231,  
Tel. +65 350 2538, Fax. +65 251 6500

**Slovakia:** see Austria

**Slovenia:** see Italy

**South Africa:** S.A. PHILIPS Pty Ltd., 195-215 Main Road Martindale,  
2092 JOHANNESBURG, P.O. Box 7430 Johannesburg 2000,  
Tel. +27 11 470 5911, Fax. +27 11 470 5494

**South America:** Rua do Rocio 220, 5th floor, Suite 51,  
04552-903 São Paulo, SÃO PAULO - SP, Brazil,  
Tel. +55 11 821 2333, Fax. +55 11 829 1849

**Spain:** Balmes 22, 08007 BARCELONA,  
Tel. +34 3 301 6312, Fax. +34 3 301 4107

**Sweden:** Kottbygatan 7, Akalla, S-16485 STOCKHOLM,  
Tel. +46 8 632 2000, Fax. +46 8 632 2745

**Switzerland:** Allmendstrasse 140, CH-8027 ZÜRICH,  
Tel. +41 1 488 2686, Fax. +41 1 481 7730

**Taiwan:** Philips Semiconductors, 6F, No. 96, Chien Kuo N. Rd., Sec. 1,  
TAIPEI, Taiwan Tel. +886 2 2134 2865, Fax. +886 2 2134 2874

**Thailand:** PHILIPS ELECTRONICS (THAILAND) Ltd.,  
209/2 Sanpavuth-Bangna Road Prakanong, BANGKOK 10260,  
Tel. +66 2 745 4090, Fax. +66 2 398 0793

**Turkey:** Talatpasa Cad. No. 5, 80640 GÜLTEPE/ISTANBUL,  
Tel. +90 212 279 2770, Fax. +90 212 282 6707

**Ukraine:** PHILIPS UKRAINE, 4 Patrice Lumumba str., Building B, Floor 7,  
252042 KIEV, Tel. +380 44 264 2776, Fax. +380 44 268 0461

**United Kingdom:** Philips Semiconductors Ltd., 276 Bath Road, Hayes,  
MIDDLESEX UB3 5BX, Tel. +44 181 730 5000, Fax. +44 181 754 8421

**United States:** 811 East Arques Avenue, SUNNYVALE, CA 94088-3409,  
Tel. +1 800 234 7381

**Uruguay:** see South America

**Vietnam:** see Singapore

**Yugoslavia:** PHILIPS, Trg N. Pasica 5/v, 11000 BEOGRAD,  
Tel. +381 11 625 344, Fax. +381 11 635 777

**For all other countries apply to:** Philips Semiconductors, Marketing & Sales Communications,  
Building BE-p, P.O. Box 218, 5600 MD EINDHOVEN, The Netherlands, Fax. +31 40 27 24825

**Internet:** <http://www.semiconductors.philips.com>

© Philips Electronics N.V. 1997

SCA55

All rights are reserved. Reproduction in whole or in part is prohibited without the prior written consent of the copyright owner.

The information presented in this document does not form part of any quotation or contract, is believed to be accurate and reliable and may be changed without notice. No liability will be accepted by the publisher for any consequence of its use. Publication thereof does not convey nor imply any license under patent- or other industrial or intellectual property rights.

Printed in The Netherlands

297027/1200/01/pp32

Date of release: 1997 Jul 09

Document order number: 9397 750 01425

*Let's make things better.*

Philips



PHILIPS