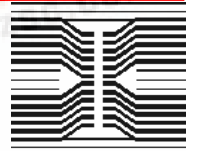






# RF Application Note



Bob Plowdrey,  (248) 374-2511  
Fax: (248) 374-2501  
E-Mail: [bob.plowdrey@infineon.com](mailto:bob.plowdrey@infineon.com)

Martin Schneider,  +49 89 234 25478  
Fax: +49 89 234 25895  
E-Mail: [martin.schneider@infineon.com](mailto:martin.schneider@infineon.com)

## Video-Modulator with PLL TDA 6060XS

<b>Table of Contents</b>	<b>-2-</b>
<b>1.0</b> Function	<b>-3-</b>
<b>2.0</b> Feature Description	<b>-3-</b>
<b>3.0</b> Programmable Features	<b>-5-</b>
<b>4.0</b> Application Circuit	<b>-6-</b>
<b>5.0</b> Performance Data	<b>-7-</b>
<b>6.0</b> Multiple IC Configuration with one Crystal Reference	<b>-10-</b>
<b>7.0</b> Evaluation Board	<b>-11-</b>
<b>7.1</b> Reference Application (UHF-Band)	<b>-12-</b>
<b>7.2</b> Application Information	<b>-13-</b>
<b>7.3</b> Components list	<b>-15-</b>
<b>7.4</b> PC-Board and Mounting Diagram	<b>-16-</b>
<b>7.5</b> Mounting Diagram	<b>-17-</b>
<b>7.6</b> Printed Circuit Board	<b>-18-</b>
<b>8.0</b> I2C Bus Software	<b>-19-</b>
<b>8.1</b> TDA6060XS Initial Setup Menus	<b>-20-</b>
<b>8.2</b> TDA6060XS IC Settings and Register Menus	<b>-21-</b>
<b>8.3</b> RF and Sound Carrier Frequency and Settings Menus	<b>-22-</b>
<b>8.4</b> Video and Sound Carrier Settings Menus	<b>-23-</b>
<b>8.5</b> Status and Miscellaneous Menus	<b>-24-</b>
<b>8.6</b> ICON Definitions and Byte Status Menu	<b>-25-</b>
<b>8.7</b> Hardware Interface	<b>-26-</b>
<b>8.8</b> Passive Hardware Interface	<b>-27-</b>
<b>9.0</b> Notes	<b>-28-</b>

## 1.0 Function

The TDA6060XS RF TV modulator is a single silicon chip, controlled by software, that translates video and audio signals to any worldwide television RF channel format. This IC is suitable for all modulator boxes including satellite receivers, cable headend, set-top boxes, video recorders and games.

## 2.0 Feature Description

The TDA6060XS IC combines a digitally programmable phase locked loop (PLL) with a multi-standard video modulator and programmable sound FM and AM modulator. This highly integrated chip allows for simpler design and lower system cost and compatibility with all world standards, including PAL, NTSC and SECAM. It offers designers maximum flexibility with an on-board PLL that permits the tuning process, gain settings and status with I<sup>2</sup>C bus microprocessor control. The frequency of the modulator oscillator can be set precisely from 30 MHz to 950 MHz in increments of 250 kHz. The frequency range VHF Low, VHF High, Hyper band and UHF can be changed with different tank circuit applications.

The modulator block (shown in Figure 1) includes:

- a digitally programmable I<sup>2</sup>C bus controlled phase locked loop (PLL) controlled
- I<sup>2</sup>C bus interface with fast mode (400 kHz) possible
- Up to four PLL I<sup>2</sup>C bus addresses selectable by the DC voltage applied at the Chip Address Selection (CAS) pin (pin 5)
- a LC tuned frequency and amplitude-stable balanced multivibrator oscillator for the VHF Low, VHF High, Hyperband and UHF range tuned with different LC tank circuits
- a software gain adjustable video amplifier
- Clamped video input with peak white level detection for I<sup>2</sup>C readable overload amplifier status to determine needed I<sup>2</sup>C bus controlled gain setting of the video amplifier
- a double balanced mixer with a double balanced output for the RF modulator
- a sound modulator for FM or AM modulation
- a programmable sound carrier oscillator with no external LC tank for all four worldwide frequencies (4.5, 5.5, 6.0 and 6.5 MHz)
- second sound carrier input for Nicam or second FM carrier applications
- high current output switch port which could be used for RF source input selection
- a 5 level A/D convertor
- test mode including a test pattern generator
- a low noise reference voltage source
- +5 V power supply operation
- ultra-compact TSSOP-28 package

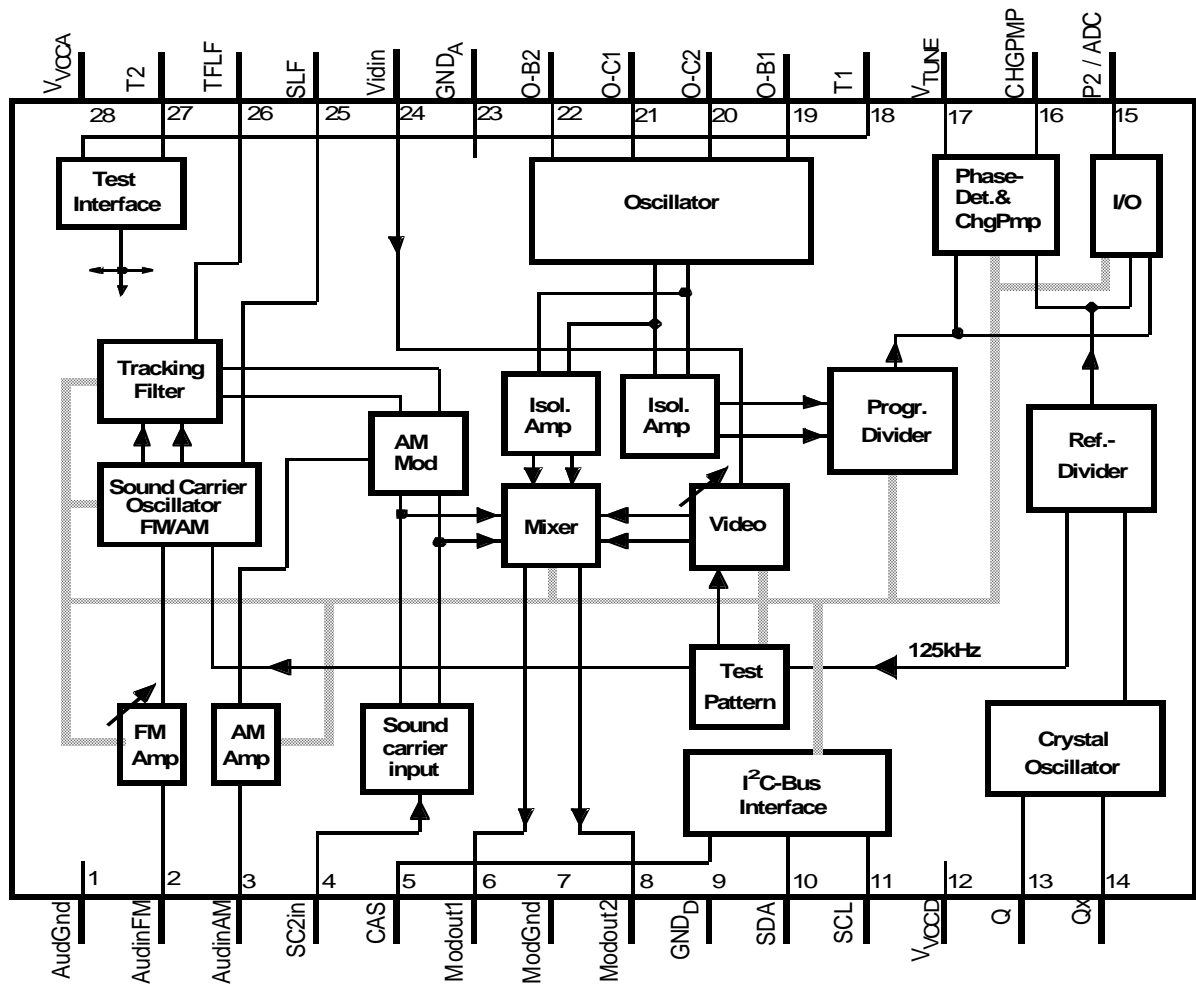


Figure 1. - TDA6060XS IC Functional Block Diagram

## 3.0 Programmable Features

The TDA6060XS gives the designer maximum flexibility by allowing many programmable features and precision settings such as Picture/Sound carrier, video gain, video modulation depth, video clipping flag and audio gain. The programmable features and settings/readings are shown in Table 1.

Software Feature	Programmable Setting/Reading
Picture/Sound Carrier Ratio	4 steps per standard: +1, 0, -1, -2 dB
Video Modulation Depth	4 steps: +5, 0, -5, -10 %
Video Gain Setting	4 steps: +1, 0, -1, -2 dB
Sound Carrier Frequency	4.5 , 5.5 , 6.0 , 6,5 MHz (AM and FM)
Audio Level Setting	4 steps: 0, -1, -2, -3 dB (only possible for FM)
RF Oscillator	On/Off
Sound Oscillator	On/Off (only possible in AM standard)
Charge Pump Current of Sound PLL	I/5I
Port Output	On/Off, Open Collector
Chip Address	4 Different Addresses, selectable by DC level at CAS input
A/D Converter Input	Read, 5 Levels
Clipping Flag	Read, Indicates Video Amplifier Overload
PLL Lock Indication Flag	Read, Set when RF Oscillator PLL is locked

**Table 1. TDA6060XS Programmable / Readable Features and Settings**

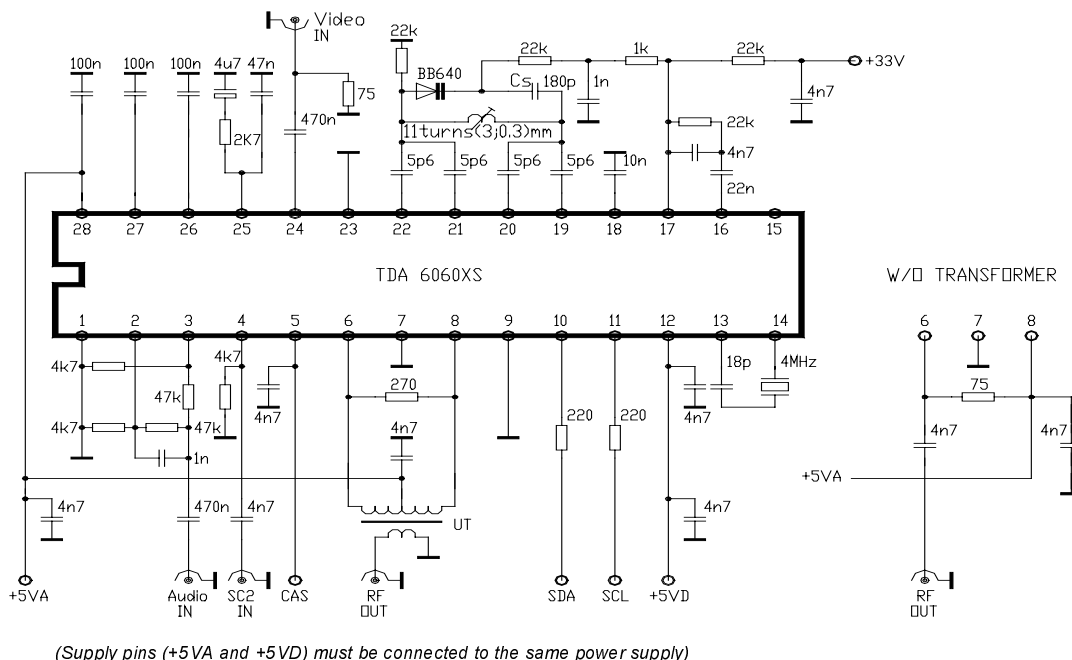
## 4.0 Application Circuit

The application circuitry for the TDA6060XS is shown in Figure 2. The TDA6060XS modulator output can be configured in a balanced or unbalanced mode (with or without a transformer). The performance compromise is that the baseband sound carrier to modulator output isolation (which is most critical in VHF Low band) decreases from -65 dBc to -50 dBc typical.

The sound carrier PLL filter is determined by the components connected to pin 25 and its -3 dB bandwidth is approximately 20 Hz. The RF oscillator PLL filter is determined by the components connected between pins 16 and 17 and its -3 dB bandwidth is approximately 1 kHz. The pre-emphasis filter is external and is located at the FM audio input (pin 2). Pre-emphasis is set to 50 usec in this application circuit.

The capacitor values used to cross-couple the RF oscillator feedback to the tank circuit (pins 19-22) depends on the application frequency. The correct capacitor values for each TV band along with a components list are shown in Section 7.2, Table 4.

It is recommended that if the RF modulator output is directly connected to a coaxial output on the application box via a capacitor, a BAV99 dual diode be placed at the coaxial output to protect the modulator output from ESD. The TDA6060XS modulator output pins (pins 6 and 8) are internally protected ESD to the 1kV human body model.



**Figure 2. VHF Low Band Application Circuit**

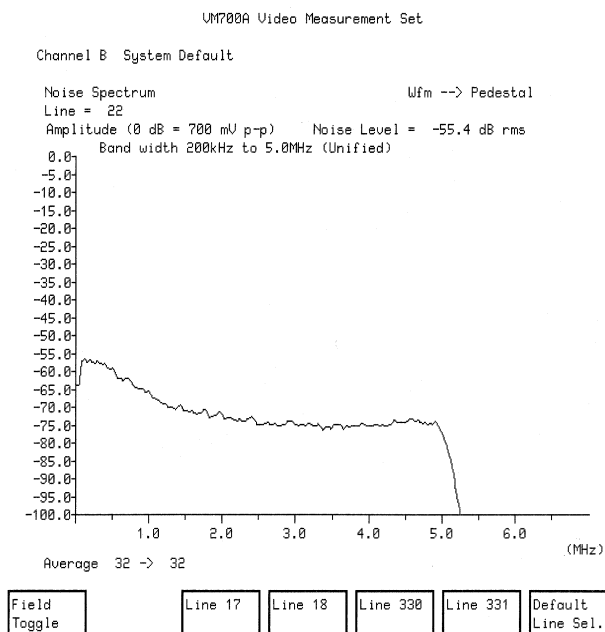
## 5.0 Performance Data

Typical values for Audio and Video Signal to Noise Ratio (S/N) and RF modulator phase noise measured on a Siemens evaluation board are shown in Table 3. The Audio and Video S/N are consistently good within the TV bands. The RF modulator oscillator phase noise shows excellent performance with a slight degradation at higher ends of the TV frequency bands. A typical video noise curve at 471.25 MHz is shown in Figure 3. A typical RF modulator oscillator noise curve at 303.25 MHz is shown in Figure 4. Note the absence of any spurious signals.

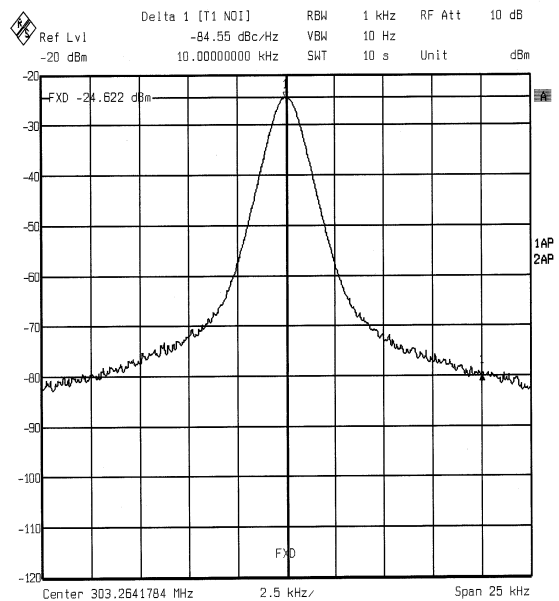
Band	Frequency (MHz)	Audio S/N Ratio *Note 2 (dB)	Video S/N Ratio *Note 1 (dB)	LO Phase Noise *Note 3 (dBc/Hz @ +/- 10kHz)
VHF Low	61.25	55	59	88
VHF High	157.25	55	58	90
VHF High	303.25	55	58	85
UHF	471.25	55	58	89
UHF	663.25	55	57	82
UHF	800.25	55	56	82

\* All measurement test conditions are described in Section 9.0, Notes.

**Table 2. Typical Noise Measurements over TV Frequency Bands**

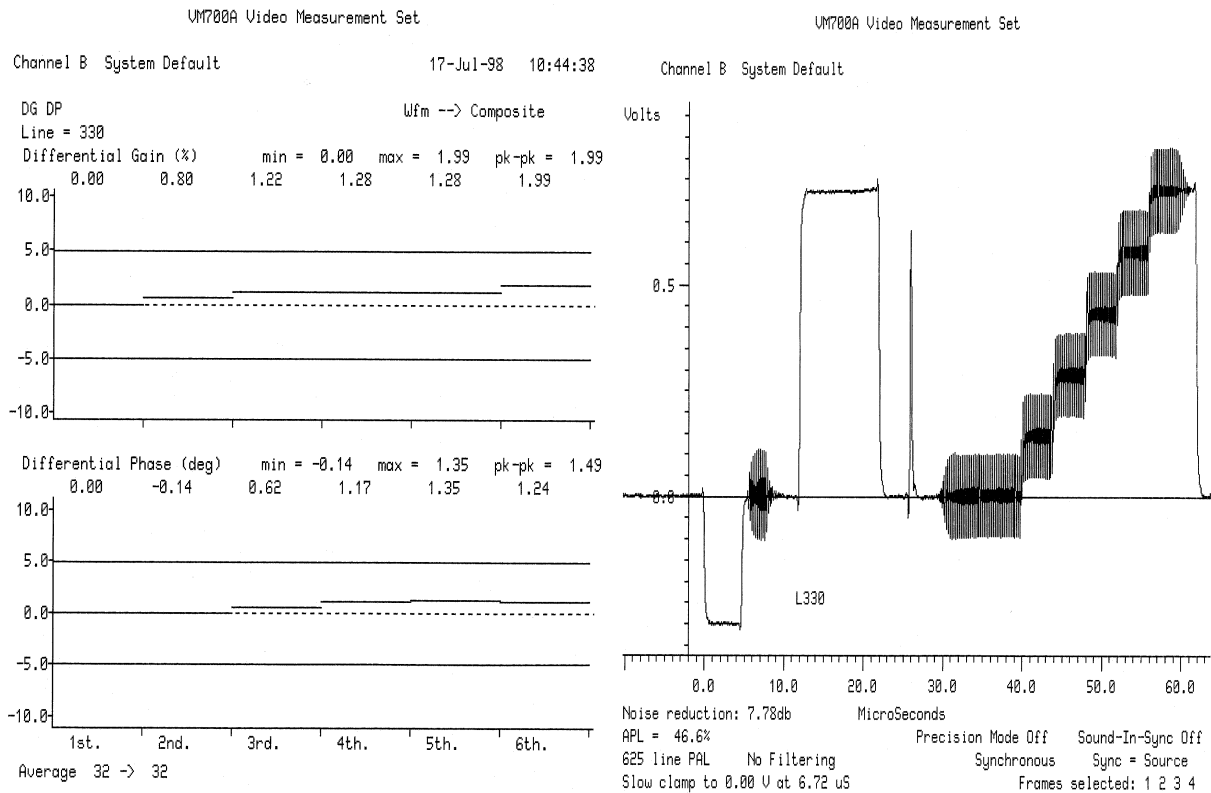


**Figure 3. Typical Video Noise Curve**



**Figure 4. RF Carrier Noise Curve At 303.25 MHz**

Typical differential gain and phase characteristics from a 5-step video pattern modulated with 4.43 MHz chroma, measured with a Tektronix VM700 video monitor, are shown in Figure 5. The video input was a fixed 500 mVpp with normal IC video modulation (90%) and gain (0 dB) settings. The video input test signal is shown in Figure 6. Typical differential gain and phase characteristics over the TV frequency band with the same video input and IC settings are shown in Table 3. These measurements show excellent results.



**Figure 5. Typical Video Differential Gain and Phase Characteristics**

**Figure 6. Video Input Test Signal**



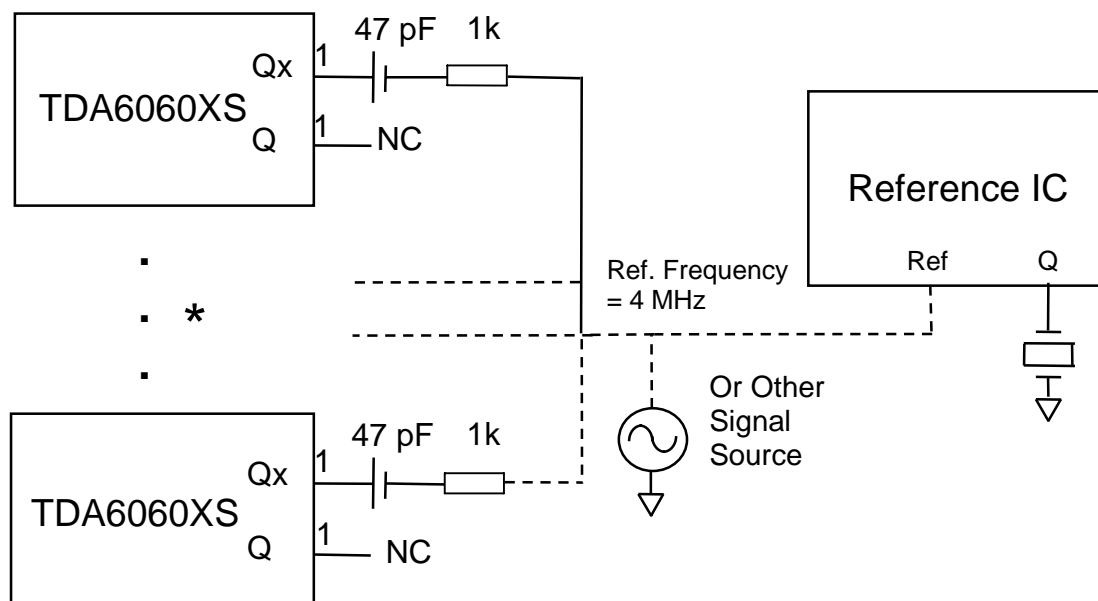
RF-Band	Frequency (MHz)	Differential Gain (*Note4) (%)	Differential Phase (*Note4) (Degree)
VHF Low	61.25	1.8	1.2
VHF High	157.25	1.8	2.0
VHF High	303.25	2.1	2.2
UHF	471.25	2.0	1.5
UHF	663.25	2.0	1.3
UHF	800.25	1.4	1.9

\*All measurement test conditions are described in Section 9.0, Notes.

**Table 3. Differential Gain and Phase Measurements**

## 6.0 Multiple IC Configuration with One Crystal Reference

To reduce system costs, a single crystal resonator can be shared among multiple ICs due to the four bus address selectable option on the TDA6060XS. A buffered external reference source from another IC (i.e. PLL, IF processor, microprocessor, etc) or crystal oscillator may be connected to drive the TDA6060XS Qx reference inputs (pin 14) via series resistors and capacitors as shown in Figure 7. The series resistors and capacitors are needed to current drive the crystal inputs. The capacitor is used as a DC block and its value is dependent on reference crystal and oscillator impedance characteristics. The 1k resistor is needed to eliminate the possibility of parasitic oscillations by the crystal oscillator and its value was determined by the crystal oscillator's specified minimum impedance (-900 Ohm). The required Qx voltage input range is 200 mVpp to 2Vpp, respectively.



\* Up to Four TDA6060XS ICs

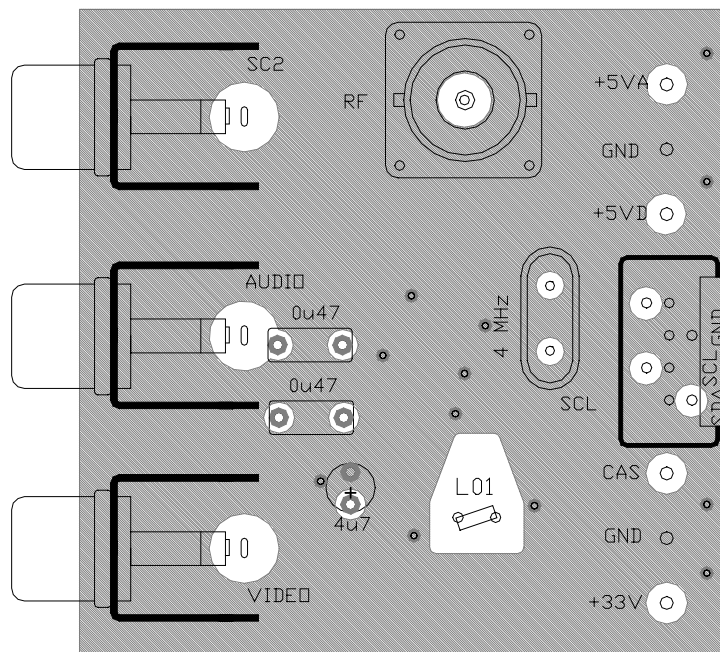
**Figure 7 – Multiple IC Configuration with a Single Crystal Reference or External Oscillator Reference Source**

## 7.0 Evaluation Board

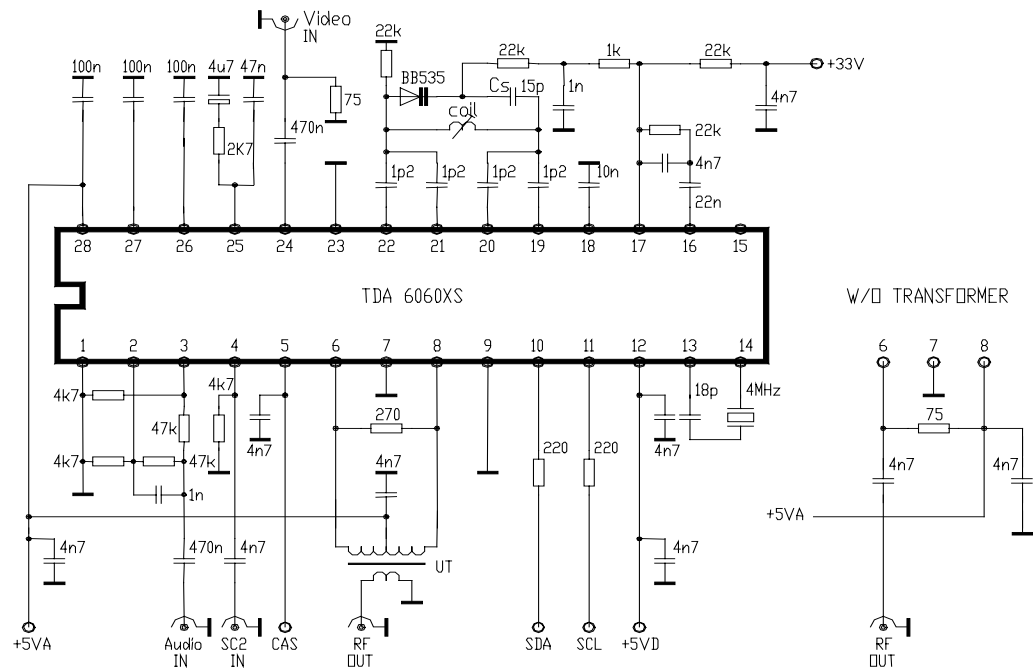
The evaluation board includes the TDA6060XS IC with applications for a complete multistandard video and sound modulator controlled via I<sup>2</sup>C bus. The frequency band can be changed to VHF Low, VHF High and UHF with different tank circuits in the application. Control Software PLLCONTR(\*) or SIMONWIN V1.61 is included with the evaluation board to control register settings. The SIMONWIN V1.61 also allows the user to check Read/Write Data.

(\*) only write data

### Evaluation Board, Upper Side



## 7.1 Reference Application (UHF Band)



(Supply pins (+5VA and +5VD) must be connected to the same power supply)

### UHF Band $V_{Tune}$ adjustment

TV-Channel	C21	C69	A83
Standard	BG	BG	M
Picture carrier	471,25MHz	855,25MHz	885,25MHz
	↓		↓
$V_{TUNE\_IC\ PIN17}$	1V	22V	26V

(adjustment with coil on evaluation board)

## 7.2 Application Information

### VHF / UHF Modulator

The frequency range VHF low or VHF high or UHF is fixed with different external components on the RF oscillator Pins 19....22 and different LC tank components. The correct capacitor values for each TV band along with a components list are shown in Table 4 .

#### Components (\*) for the RF-oscillator

Band	Frequency range	Value for C19/20/21/22	Value for Cs	Variablecap. Diode	Coil:Num of turns	Coil diameter	Coil:Wire diameter
VHF low	45..145 MHz	5p6	180p	BB 640	11	3.0 mm	0.3 mm
VHF high	140..475 MHz	3p3	220p	BB 640	3	3.0 mm	0.4 mm
UHF	465..860 MHz	1p2	15p	BB 535	2	2.5 mm	0.5 mm

**Table 4. Evaluation Board Components List**

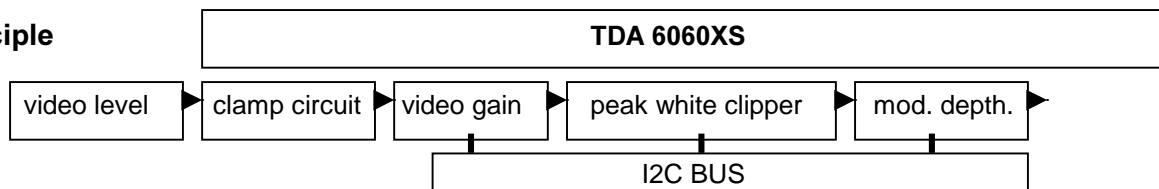
### Design note for Printed Circuit Board (PCB)

The optimum results are achieved with a double-sided PCB. The RF oscillator parts and PCB traces need to be physically separated from the RF output parts and PCB traces as much as possible to minimize parasitic coupling between the RF oscillator and RF output. All IC and component grounds are directly connected with the PCB upper side ground plane.

## Note for Video Clipping Level

The nominal video signal input level is 500mVpp. In video setting menu the modulation depth can be controlled in four steps (+5%/Norm/-5%/-10%). In position „-10%“ and video gain „0dB“, the typical modulation depth is 80%. A clipping circuit is activated to limit the white level in case the nominal video input level is exceeded by approx. 12%. This prevents a modulation depth of more than 100%. The status of the clipping detector can be read via I2C bus by means of a clipping flag which is automatically set in case of clipping.

## Principle



## Note for Power Supply Voltage

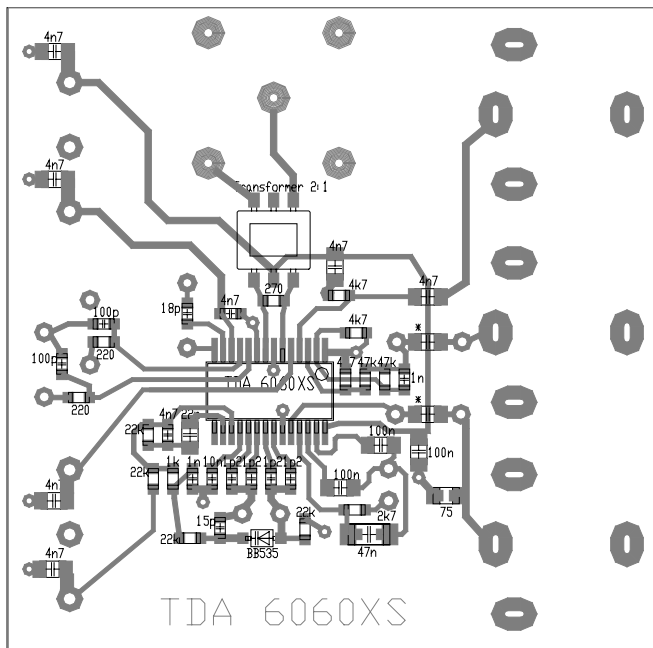
The TDA 6060XS uses 2 supply pins for better on chip decoupling. During normal operation the 2 supply pins (V<sub>VCCD</sub> and V<sub>VCCA</sub>) must be connected to the same power supply.

The application board supports individual measurement of analog and digital supply current . In normal application **only one supply source must be used.**

## 7.3 Components list

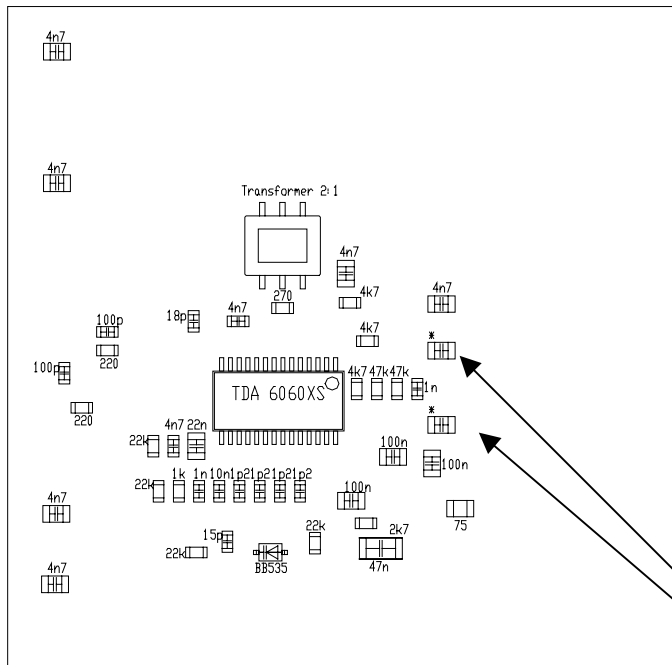
<b>Modulator IC</b>	1	TDA 6060XS	SO 28
<b>Variable cap. Diode</b>	1	(*)	SOD 323
<b>Capacitors</b>	4	(*) C19/20/21/22	0603
	1	(*) Cs	0603
	1	18pF	0603
	2	1nF	0603
	2	4,7nF	0603
	7	4,7nF	0805
	1	10nF	0603
	1	22nF	0805
	1	47nF	1206
	2	100nF	0805
	1	100nF/50V	0805
	2	470nF	foil cap (RM 5mm)
	1	4,7µF/25V	Elko (RM 2,5mm)
<b>Resistors</b>	1	75R	0805
	2	220R	0603
	1	270R (75)	0603
	1	1k	0603
	3	4,7k	0603
	1	2k7	0603
	4	22k	0603
	2	47k	0603
<b>Additional components</b>	1	Transformer 2:1 turns (primary 2+2; secondary 2) (TOKO; B4F Type 617PT-1026) (S+M; Type B78408-B1087-A3)	SMD
	1	4MHz Quartz	HC 49 C
	1	Stocko-Connector	4-pin
	1	BNC-Connector	
	3	Cinch-Connectors	
	1	(*) Coil	
	(*)	LC tank circuit components, <i>values are shown in Chapter 7.2 Table 4</i>	

## 7.4 PC-Board and Mounting Diagram



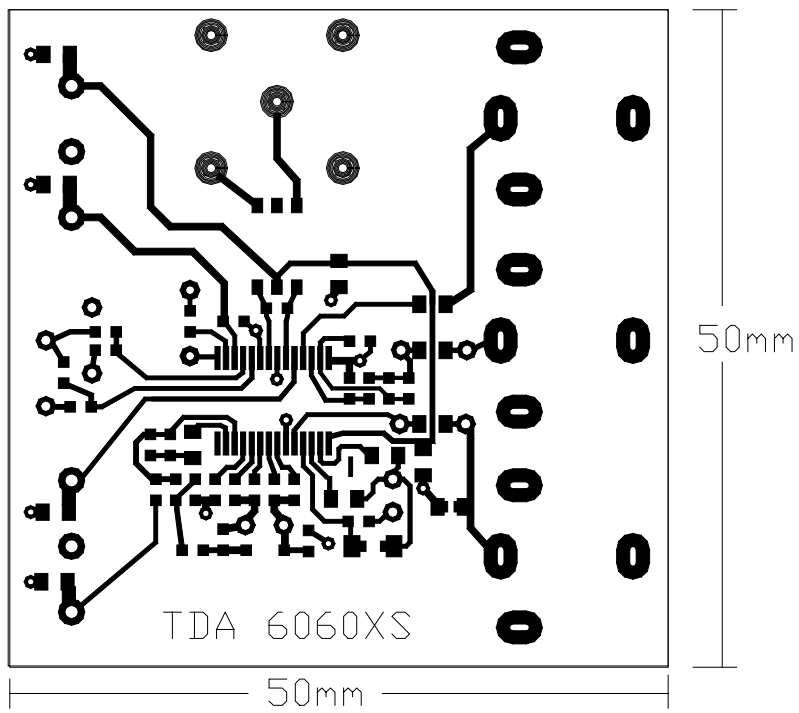


## 7.5 Mounting Diagram



\* foil caps

## 7.6 Printed Circuit Board



## 8.0 I2C Bus Software

### **SIMONWIN Software** (Siemens I2C Bus Monitor for Windows)

SIMONWIN is a menu driven software package running under Microsoft Windows V3.1 or higher. Full mouse and keyboard control for all functions are supported.

The Installation disk contains the following file:                   **SIMW161.zip**

After unzipping the following files are available:                **SETUP.EXE**  
  **SIMW161.DOC**

Installation procedure with **SETUP.EXE**

### **SIMON I2C-Interface**

The SIMON LPT Interface is used to write and read I2C data.

1. Connect the SIMON LPT Interface (SUB-D 25) to PC (LPT1 or 2)
2. Three wires (SDA; SCL and GND) are connected with the SIMON Interface (**SUB-D9**; Pin2=SDA; Pin3=SCL; Pin5=GND; Pin7=+5V).
3. Turn on the supply voltage +5V to the SIMON Interface

### **Start of program SIMonWin**

#### **Selection: TDA 6060XS**

1. Open window "SIMON"
2. **Click to "Options" and select Channels** (\*)
3. **Select LPT1 or LPT2, Delay e.g.=1usec, I2C and Channel e.g.=0 and click "OK"** (\*)
4. Click to "IC"
5. Click to "Add IC..."
6. Select IC "TDA 6060XS" in window "Open IC"
7. Start TDA 6060XS with click to "OK"
8. Change to Address C2 in window "IC settings" and click "OK"
9. Window "Project" is open  
double click to "TDA 6060XS Chipaddr C2 Channel 0"
10. The window "Register" is open (Data bytes of TDA 6060XS)
11. Change to window "Value" with click to "IC" and "Value"
12. Click to "Interface" and "Animate" button. In this mode, every modification of register or memory data will be immediately transmitted to the IC.
13. If you change any byte please push always the "Download All" button.  
(Bugs in the routine "Animate" or "Repetitive Write" are eliminated).

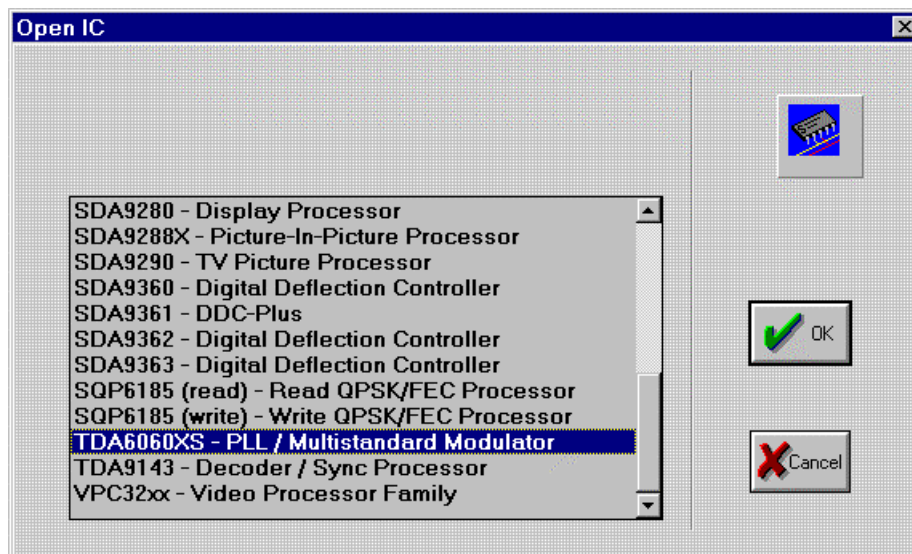
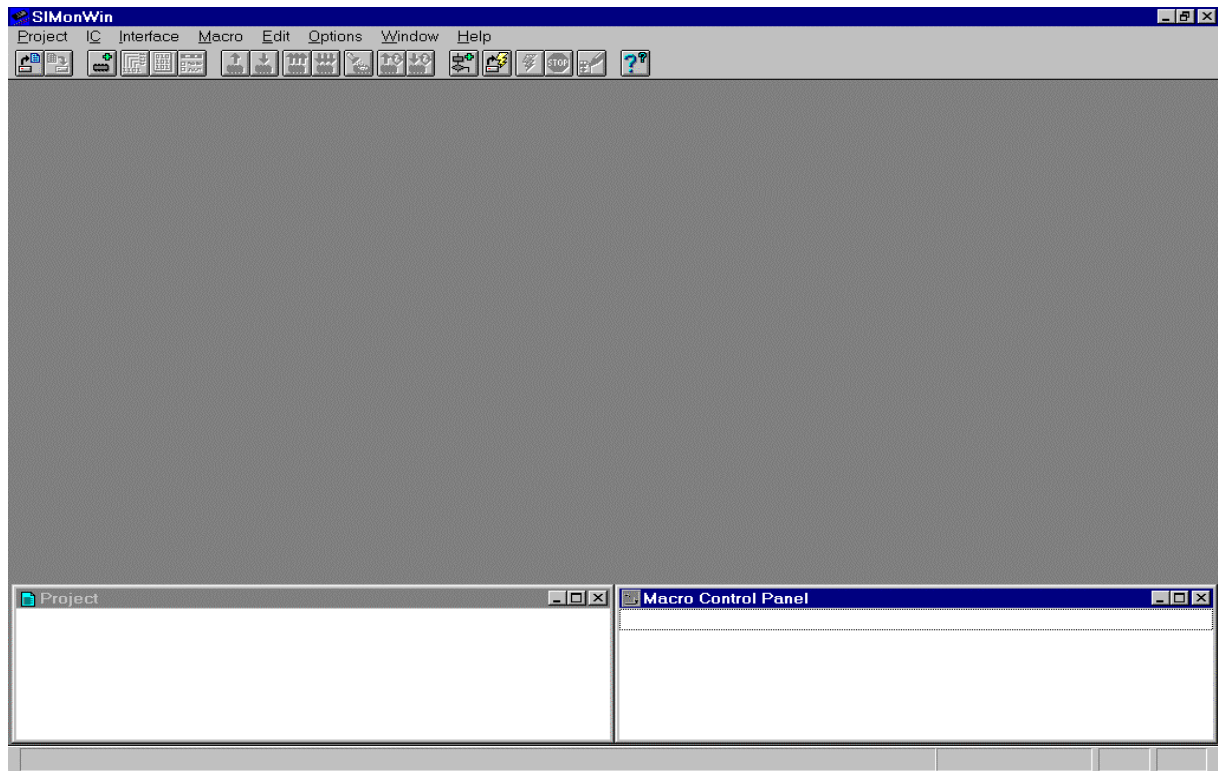
Only for configuration (\*)

#### **Read modulus for status byte**

1. Change to window "Register"
2. Click to "Interface" and "Repetitive Read"

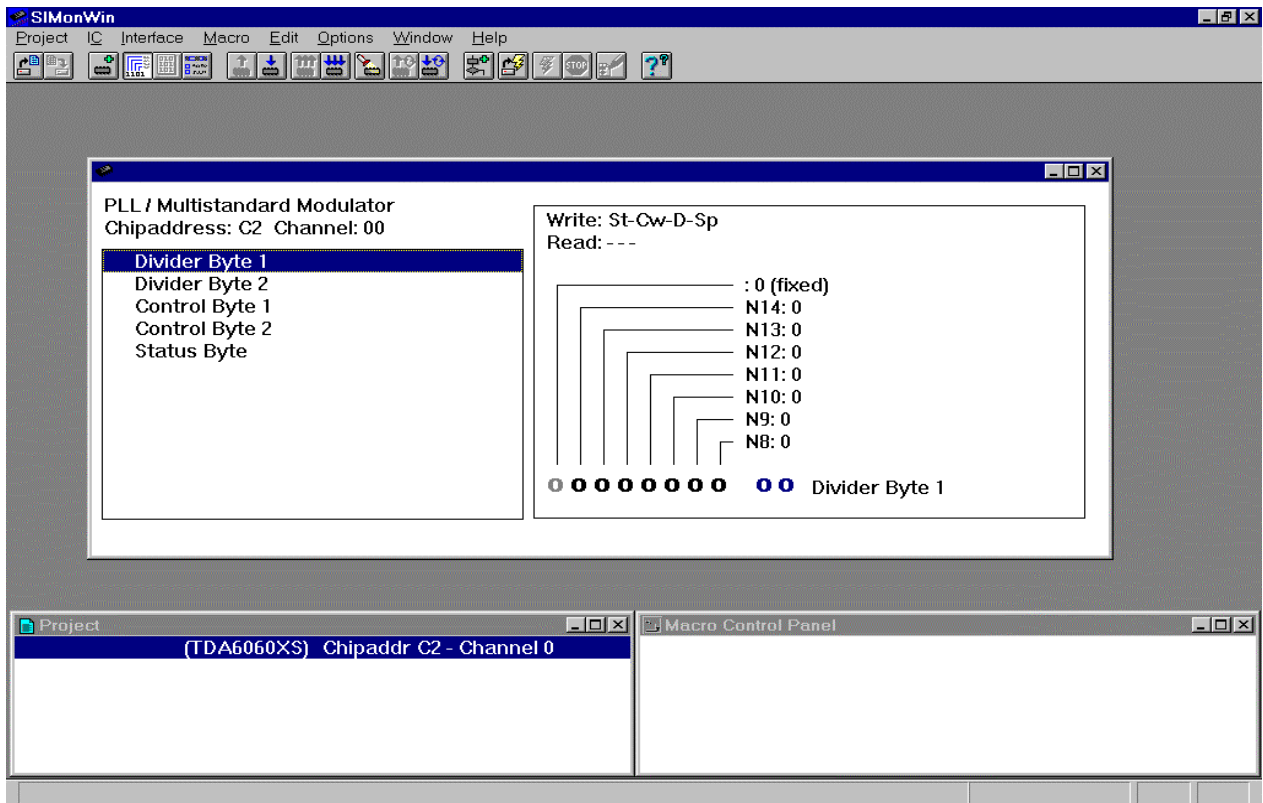
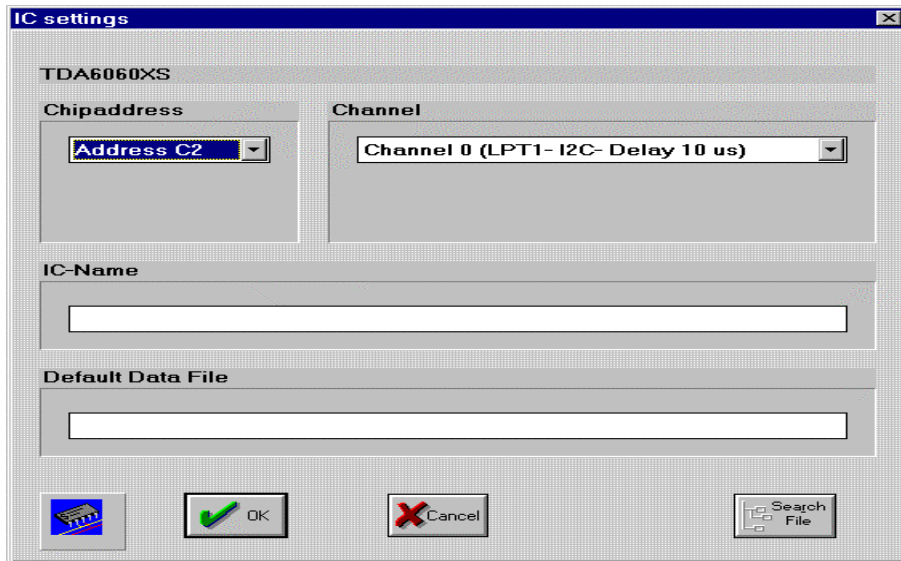
## 8.1 TDA6060XS Initial Setup Menus

SIMON Software V1.61



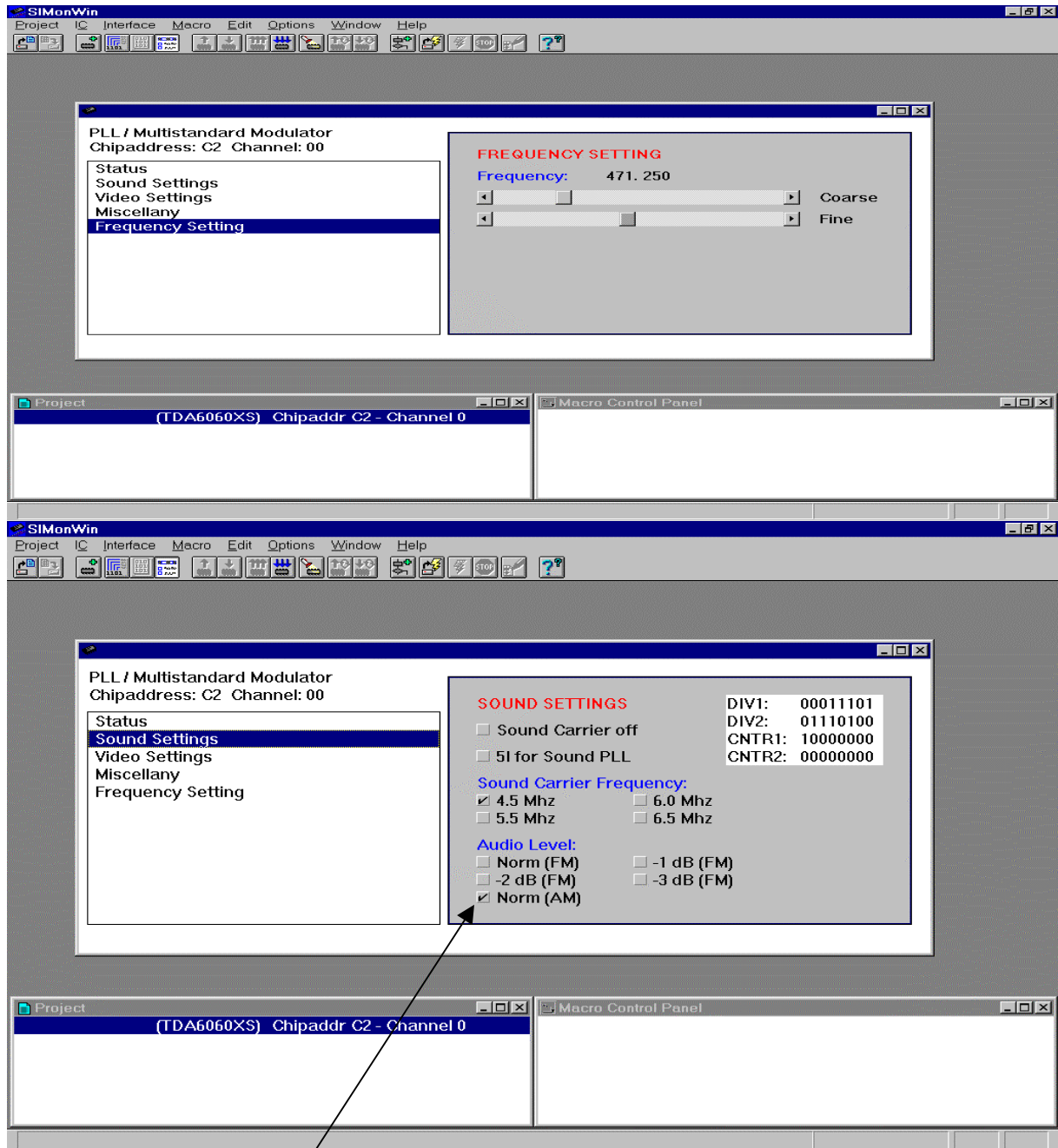
## 8.2 TDA6060XS Initial Setup and Register Menus

SIMON Software V1.61



## 8.3 RF and Sound Carrier Frequency Setting Menus

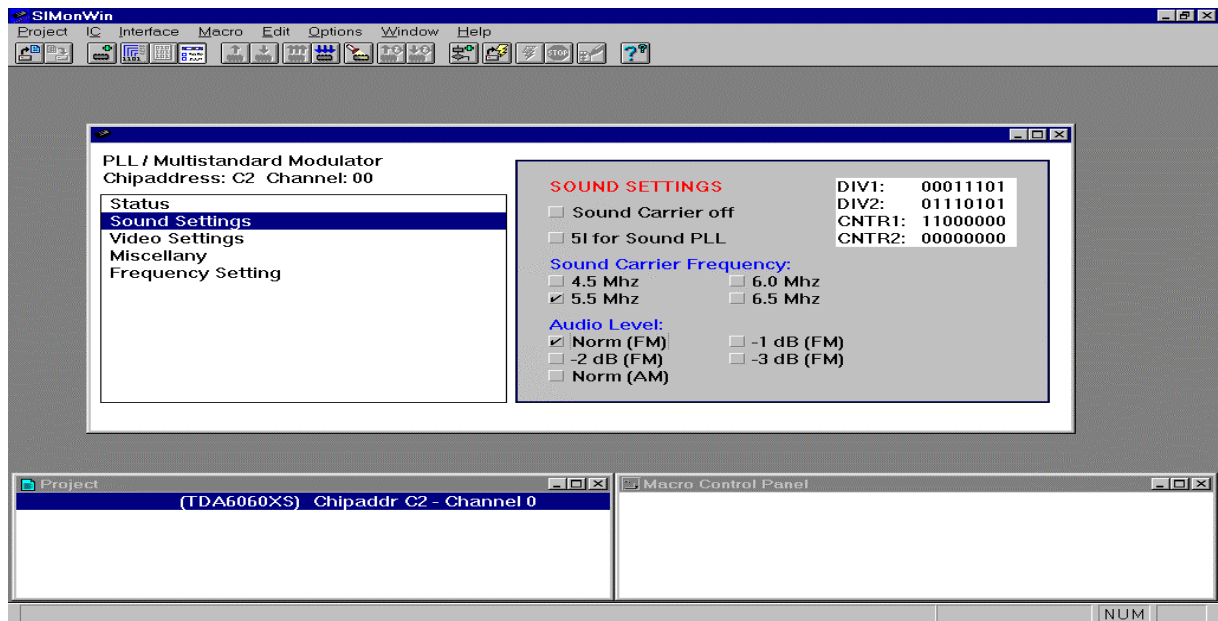
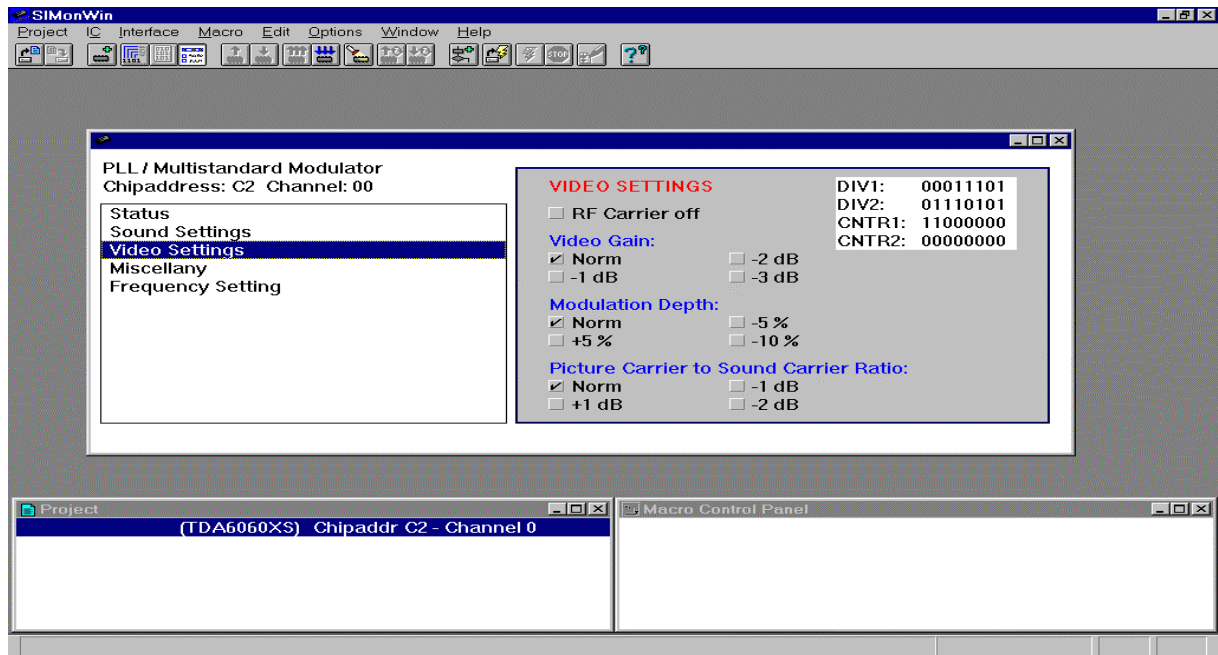
SIMON Software V1.61



**Note: SIMON software start allways in this configuration.**

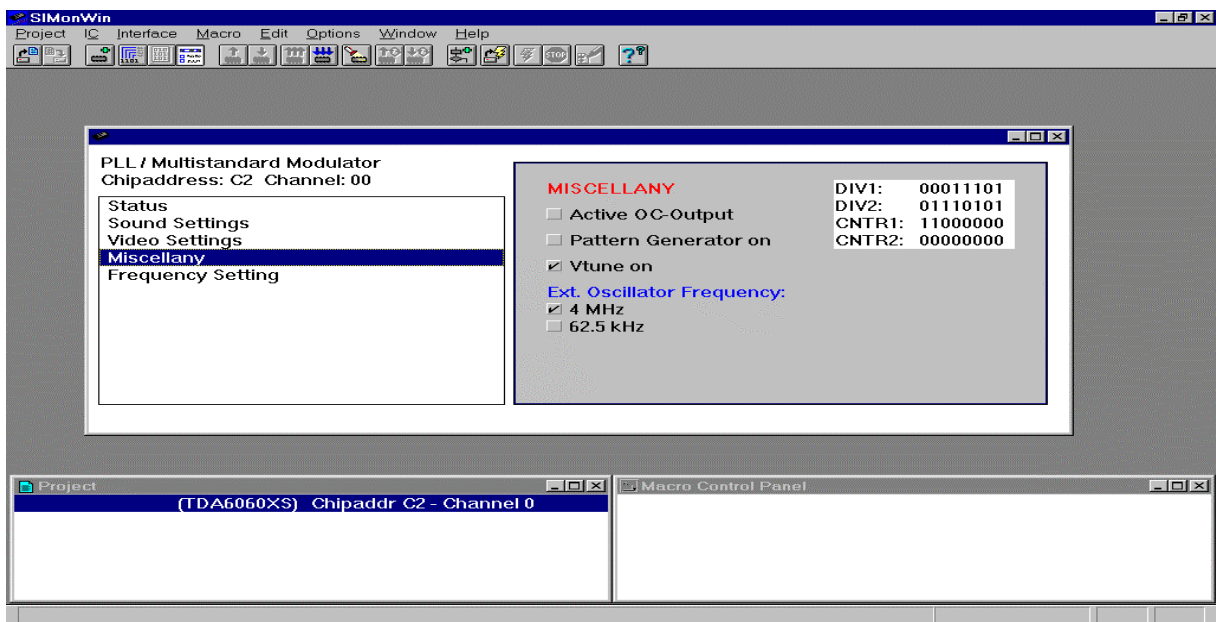
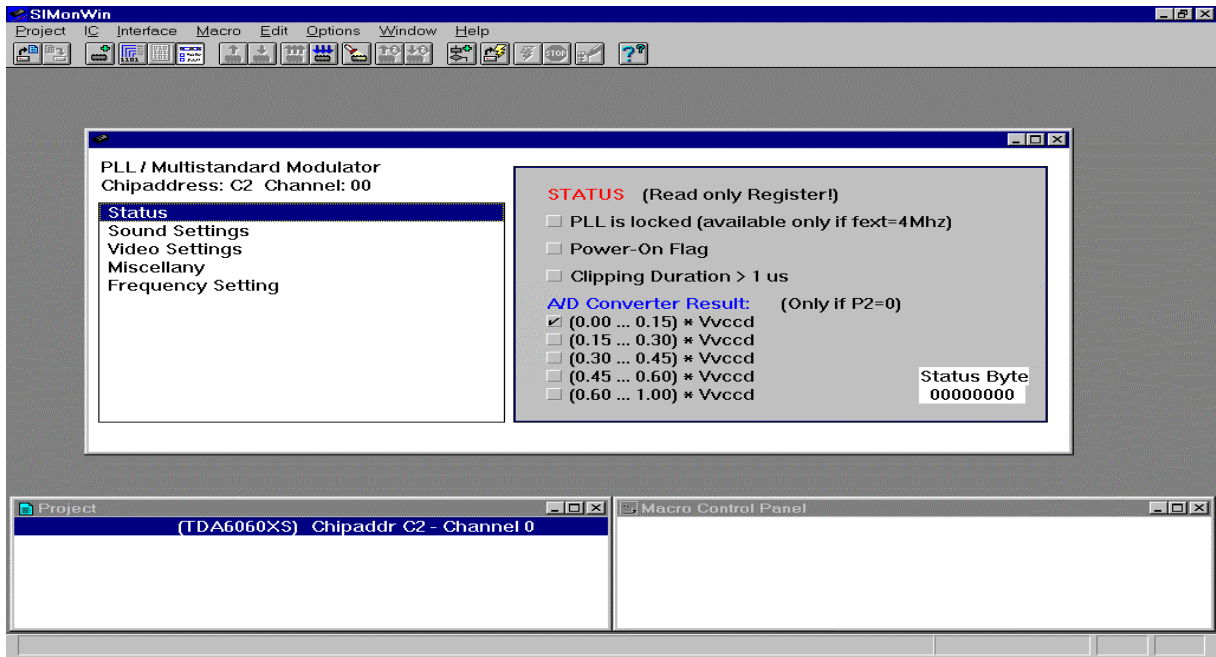
## 8.4 Video and Sound Carrier Settings Menus

SIMON Software V1.61



## 8.5 Status and Miscellaneous Menus

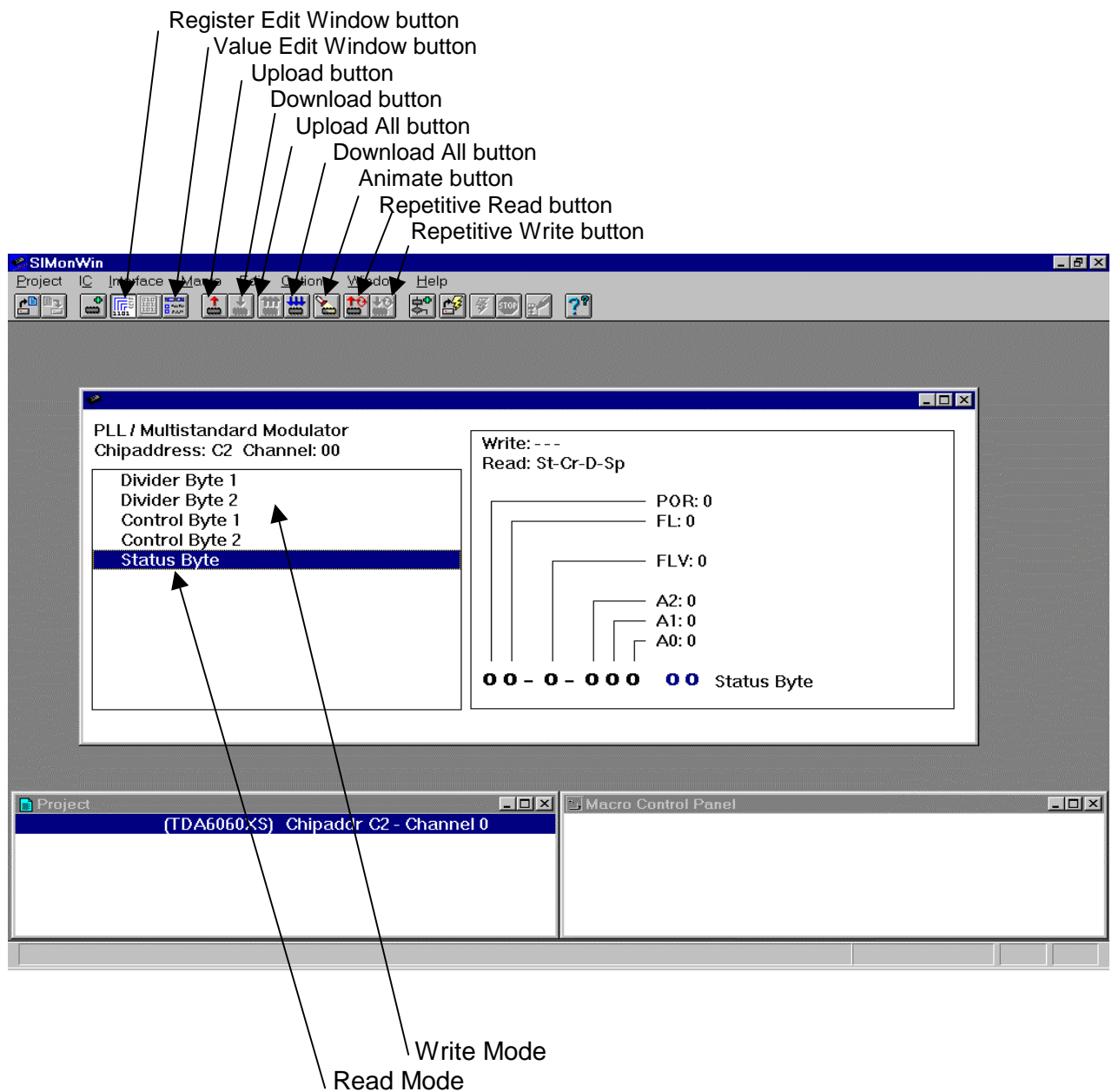
SIMON Software V1.61





## 8.6 ICON Definitions and Byte Status Menu

SIMON Software V1.61



Register Edit Window button  
 Value Edit Window button  
 Upload button  
 Download button  
 Upload All button  
 Download All button  
 Animate button  
 Repetitive Read button  
 Repetitive Write button

Write: ---  
 Read: St-Cr-D-Sp

POR: 0  
 FL: 0  
 FLV: 0  
 A2: 0  
 A1: 0  
 A0: 0

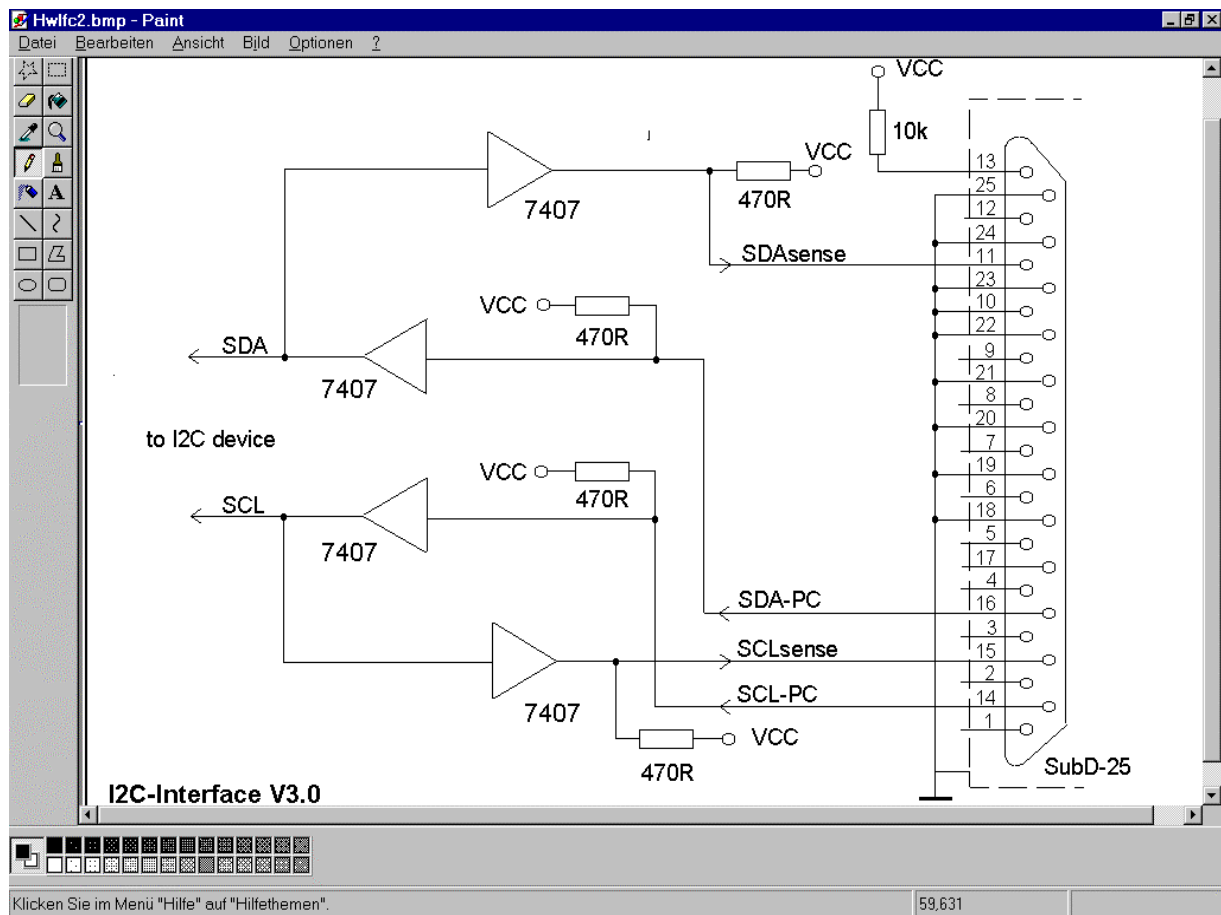
00 - 0 - 000 00 Status Byte

Write Mode  
 Read Mode

## 8.7 I2C Bus Hardware Interface

SIMON Software V1.61

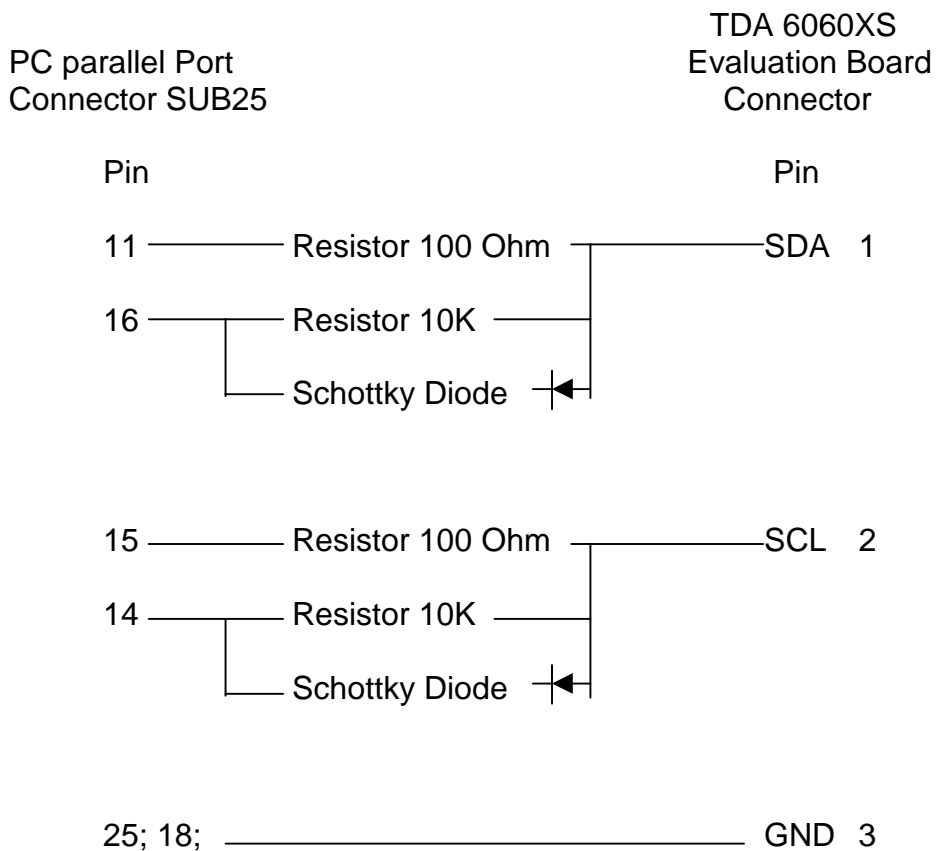
SIMON for Windows supports an I2C-protocol using the PC parallel port. The channel parameter can be modified in the channel settings dialog. The connected hardware should correspond to the following diagram. This hardware interface or the passive interface described in Section 8.8 is included with the TDA6060XS evaluation board.



## 8.8 Passive Hardware Interface

SIMON Software V1.61

Wiring scheme of the passiv Hardware Interface:



This passive interface should only be used for short connector cable connections (1.5 m maximum length) from PC parallel port to Evaluation Board.

## 9.0 Notes

**(\*Note1)** Test Conditions Video Signal to Noise Ratio (S/N)

Ratio between the CCIR17 line bar amplitude (reference signal = white level – black level) and the RMS value of the noise on a black line (line 22 or 335) measured on the video signal after TV-demodulator. Measurement range 200kHz.....5MHz.

Measurement weighted.

Video input signal (Colour bar) = 500mVpp; modulation depth <90%; video gain=0dB;

List of Equipment:

TV-Generator SGPF (R&S); TV-Measuring Receiver 326 (THL)

Video Measurement Set VM700A (Tektronix)

**(\*Note2)** Test Conditions FM Audio Signal to Noise Ratio (S/N)

Audio frequency 1kHz; audio level >830mV (RMS); deviation +-50kHz;

video signal colorbar (500mVpp); modulation depth <90%; video gain = 0dB;

filter: CCIR 468-3 quasi peak; line frequency blocking.

Measurement with pre- and de-emphasis.

List of Equipment:

TV-Generator SGPF (R&S); TV-Measuring Receiver 326 (THL);

Audio Analyzer UPA (R&S)

**(\*Note3)** Test Conditions LO Phase Noise RF-Carrier

All modulator inputs terminated with 75 Ohm.

RF-carrier phase noise measured at 10kHz;

List of Equipment:

Spectrum Analyzer FSEA (R&S)

**(\*Note4)** Test Condition Differential Gain and Phase

Measured on CCIR 330 line;

Video signal (CCIR 330/5) = 5-step staircase with chroma carrier; video level = 500mVpp;

I2C-Bus settings: modulation depth < 90%; (clipping flag = 0); video gain = 0dB;

List of Equipment:

TV-Generator SGPF (R&S); TV-Measuring Receiver 326 (THL);

Video Measurement Set VM700A (Tektronix)