

INTEGRATED CIRCUITS

DATA SHEET

TDA6101Q Video output amplifier

Preliminary specification

1995 Feb 07

Supersedes data of November 1991

File under Integrated Circuits, IC02

Philips Semiconductors

PHILIPS



Video output amplifier**TDA6101Q****FEATURES**

- High bandwidth and high slew rate
- No external heatsink required
- Black-current measurement output for Automatic Black-current Stabilization (ABS)
- Two cathode outputs; one for DC currents, and one for transient currents
- A feedback output separated from the cathode outputs
- Internal protection against positive appearing Cathode-Ray Tube (CRT) flashover discharges
- ESD protection
- Simple application with a variety of colour decoders
- Differential input with a designed maximum common mode input capacitance of 3 pF, a maximum differential mode input capacitance of 0.5 pF and a differential input voltage temperature drift of 20 $\mu\text{V}/\text{K}$
- Defined switch-off behaviour.

GENERAL DESCRIPTION

The TDA6101Q is a video output amplifier with 9 MHz bandwidth. The device is contained in a single in-line 9-pin medium power (DBS9MPF) package, using high-voltage DMOS technology, intended to drive the cathode of a colour CRT.

QUICK REFERENCE DATA

SYMBOL	PARAMETER	CONDITIONS	MIN.	TYP.	MAX.	UNIT
V_{DDH}	high level supply voltage		0	–	250	V
V_{DDL}	low level supply voltage		0	–	14	V
I_{DDH}	quiescent high voltage supply current	$V_{oc} = 0.5V_{DDH}$	3.5	4.4	5.5	mA
I_{DDL}	quiescent low voltage supply current	$V_{oc} = 0.5V_{DDH}$	2.2	2.8	3.5	mA
V_I	input voltage		0	–	V_{DDL}	V
V_{oc}, V_{fb}	output voltage		V_{DDL}	–	V_{DDH}	V
T_{stg}	storage temperature		–55	–	+150	$^{\circ}\text{C}$
T_{amb}	operating ambient temperature		–20	–	+65	$^{\circ}\text{C}$

ORDERING INFORMATION

TYPE NUMBER	PACKAGE		
	NAME	DESCRIPTION	VERSION
TDA6101Q	DBS9MPF	plastic DIL-bent-SIL medium power package with fin; 9 leads	SOT111-1

Video output amplifier

TDA6101Q

BLOCK DIAGRAM

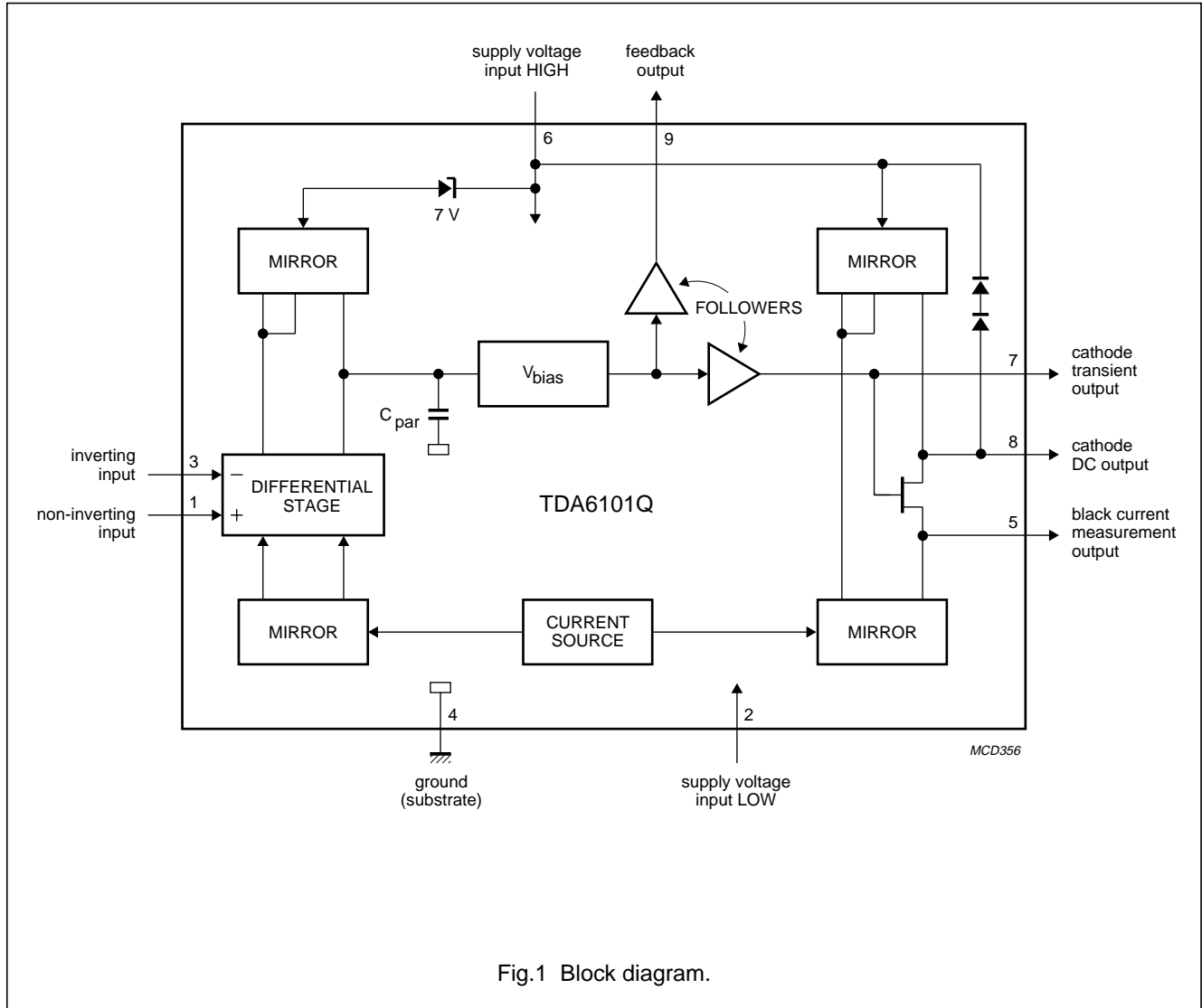

Video output amplifier

TDA6101Q

PINNING

SYMBOL	PIN	DESCRIPTION
V_{ip}	1	non-inverting voltage input
V_{DDL}	2	supply voltage LOW
V_{in}	3	inverting voltage input
GND	4	ground, substrate
I_{om}	5	black current measurement output
V_{DDH}	6	supply voltage HIGH
V_{cn}	7	cathode transient voltage output
V_{oc}	8	cathode DC voltage output
V_{fb}	9	feedback voltage output

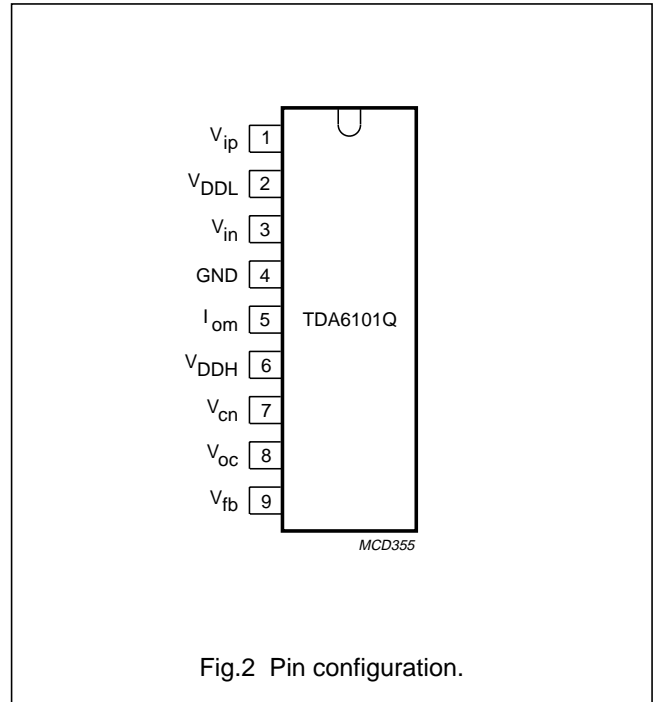

Video output amplifier

TDA6101Q

LIMITING VALUES

In accordance with the Absolute Maximum Rating System (IEC 134). Voltages measured with respect to GND (pin 4); currents as specified in Fig.1; unless otherwise specified.

SYMBOL	PARAMETER	CONDITIONS	MIN.	MAX.	UNIT
V_{DDH}	high level supply voltage		0	250	V
V_{DDL}	low level supply voltage		0	14	V
V_I	input voltage		0	V_{DDL}	V
V_{Idm}	differential mode input voltage		-6	+6	V
V_{om}	measurement output voltage		0	V_{DDL}	
V_{oc}	cathode output voltage		V_{DDL}	V_{DDH}	V
V_{fb}	feedback output voltage		V_{DDL}	V_{DDH}	V
I_{in}, I_{ip}	input current		0	1	mA
I_{ocsmL}	low non-repetitive peak cathode output current	flashover discharge = 100 μ C	0	5	A
I_{ocsmH}	high non-repetitive peak cathode output current	flashover discharge = 100 nC	0	10	A
P_{tot}	total power dissipation		0	1.9	W
T_{stg}	storage temperature		-55	+150	$^{\circ}$ C
T_j	junction temperature		-20	+150	$^{\circ}$ C
V_{es}	electrostatic handling				
	human body model (HBM)		-	> 1500	V
	machine model (MM)		-	> 400	V

HANDLING

Inputs and outputs are protected against electrostatic discharge in normal handling. However, to be totally safe, it is desirable to take normal precautions appropriate to handling MOS devices (see "Handling MOS Devices").

QUALITY SPECIFICATION

Quality specification "SNW-FQ-611 part E" is applicable, except for ESD Human body model see Chapter "Limiting values", and can be found in the "Quality reference handbook" (ordering number 9398 510 63011).

THERMAL CHARACTERISTICS

SYMBOL	PARAMETER ⁽¹⁾	VALUE	UNIT
$R_{th\ j-a}$	thermal resistance from junction to ambient in free air	56	K/W
$R_{th\ j-c}$	thermal resistance from junction to case	12	K/W

Note

1. External heatsink not required.

Video output amplifier

TDA6101Q

CHARACTERISTICS

Operating range: $T_{amb} = -20$ to 65 °C; $V_{DDH} = 180$ to 210 V; $V_{DDL} = 10.8$ to 13.2 V; $V_{ip} = 2.6$ to 5 V;
 $V_{om} = 1.4$ V to V_{DDL} .

Test conditions (unless otherwise specified): $T_{amb} = 25$ °C; $V_{DDH} = 200$ V; $V_{DDL} = 12$ V; $V_{ip} = 5$ V; $V_{om} = 6$ V; $C_L = 10$ pF
(C_L consists of parasitic and cathode capacitance); measured in test circuit Fig.3.

SYMBOL	PARAMETER	CONDITIONS	MIN.	TYP.	MAX.	UNIT
I_{DDH}	quiescent HIGH voltage supply current	$V_{oc} = 0.5V_{DDH}$	3.5	4.4	5.5	mA
I_{DDL}	quiescent LOW voltage supply current	$V_{oc} = 0.5V_{DDH}$	2.2	2.8	3.5	mA
I_{bias}	input bias current	$V_{oc} = 0.5V_{DDH}$	0	–	20	μA
I_{offset}	input offset current	$V_{oc} = 0.5V_{DDH}$	–3	–	+3	μA
$I_{om(offset)}$	offset current of measurement output	$I_{oc} = 0$ μA; –1.0 V < V_{1-3} < 1.0 V; 1.4 V < V_{om} < V_{DDL}	–5	0	+5	μA
$\frac{\Delta I_{om}}{\Delta I_{oc}}$	linearity of current transfer	–10 μA < I_{oc} < 3 mA; –1.0 V < V_{1-3} < 1.0 V; 1.4 V < V_{om} < V_{DDL}	0.9	1.0	1.1	
V_{offset}	input offset voltage	$V_{oc} = 0.5V_{DDH}$	–50	–	+50	mV
$V_{oc(min)}$	minimum output voltage	$V_{1-3} = -1$ V	–	–	20	V
$V_{oc(max)}$	maximum output voltage	$V_{1-3} = -1$ V	$V_{DDH} - 12$	–	–	V
GB	gain-bandwidth product of open-loop gain: $V_{fb} / V_{i, dm}$	$f = 500$ kHz; $V_{ocDC} = 100$ V	–	0.8	–	GHz
B_S	small signal bandwidth	$V_{ocAC} = 60$ V (p-p); $V_{ocDC} = 100$ V	7	9	–	MHz
B_L	large signal bandwidth	$V_{ocAC} = 100$ V (p-p); $V_{ocDC} = 100$ V	5.5	7	–	MHz
t_{pd}	cathode output propagation delay time 50% input to 50% output	$V_{ocAC} = 100$ V (p-p); $V_{ocDC} = 100$ V square wave; $f < 1$ MHz; $t_r = t_f = 40$ ns; see Figs 4 and 5	27	38	49	ns
t_r	cathode output rise time 10% output to 90% output	$V_{oc} = 50$ to 150 V square wave; $f < 1$ MHz; $t_f = 40$ ns; see Fig.4	43	55	68	ns
t_f	cathode output fall time 90% output to 10% output	$V_{oc} = 150$ to 50 V square wave; $f < 1$ MHz; $t_r = 40$ ns; see Fig.5	43	55	68	ns
t_s	settling time 50% input to (99% < output < 101%)	$V_{ocAC} = 100$ V (p-p); $V_{ocDC} = 100$ V square wave; $f < 1$ MHz; $t_r = t_f = 40$ ns; see Figs 4 and 5	–	–	350	ns
SR	slew rate between 50 V to 150 V	$V_{1-3} = 2$ V (p-p) square wave; $f < 1$ MHz; $t_r = t_f = 40$ ns	–	1700	–	V/μs

Video output amplifier

TDA6101Q

SYMBOL	PARAMETER	CONDITIONS	MIN.	TYP.	MAX.	UNIT
O_v	cathode output voltage overshoot	$V_{ocAC} = 100$ V (p-p); $V_{ocDC} = 100$ V square wave; $f < 1$ MHz; $t_r = t_f = 40$ ns; see Figs 4 and 5; note 1	–	9	–	%
SVRRH	high supply voltage rejection ratio	$f < 50$ kHz; note 2	–	85	–	dB
SVRRL	low supply voltage rejection ratio	$f < 50$ kHz; note 2	–	70	–	dB

Notes

1. If the difference between V_{DDL} and V_{ip} is less than 7 V, overshoot cannot be specified.
2. SVRR: The ratio of the change in supply voltage to the change in input voltage when there is no change in output voltage.

Cathode output

The cathode output is protected against peak currents (caused by positive voltage peaks during high-resistance flash) of 5 A maximum with a charge content of 100 μ C.

The cathode is also protected against peak currents (caused by positive voltage peaks during low-resistance flash) of 10 A maximum with a charge content of 100 nC.

Flashover protection

The TDA6101Q incorporates protection diodes against CRT flashover discharges that clamp the cathode output pin to the V_{DDH} pin. The DC supply voltage at the V_{DDH} pin has to be within the operating range of 180 to 210 V to ensure that the Absolute Maximum Rating for V_{DDH} of 250 V will not be exceeded during flashover. To limit the diode current, an external 820 Ω carbon high-voltage resistor in series with the cathode output and a 2 kV spark gap are needed (for this resistor-value, the CRT has to be connected to the main PCB). This addition produces an increase in the rise and fall times of approximately 5 ns and a decrease in the overshoot of approximately 3%.

V_{DDH} to GND must be decoupled:

1. With a capacitor >20 nF with good HF behaviour (e.g. foil). This capacitance must be placed as close as possible to pins 6 and 4, but definitely within 5 mm.
2. With a capacitor >10 μ F on the picture tube base print (common for three output stages).

V_{DDL} to GND must be decoupled:

1. With a capacitor >20 nF with good HF behaviour (e.g. ceramic). This capacitance must be placed as close as possible to pins 2 and 4, but definitely within 10 mm.

Switch-off behaviour

The switch-off behaviour of the TDA6101Q is defined: when the bias current becomes zero, at V_{DDL} (pin 2) lower than approximately 5 V, all the output pins (pins 7, 8 and 9) will be high.

Video output amplifier

TDA6101Q

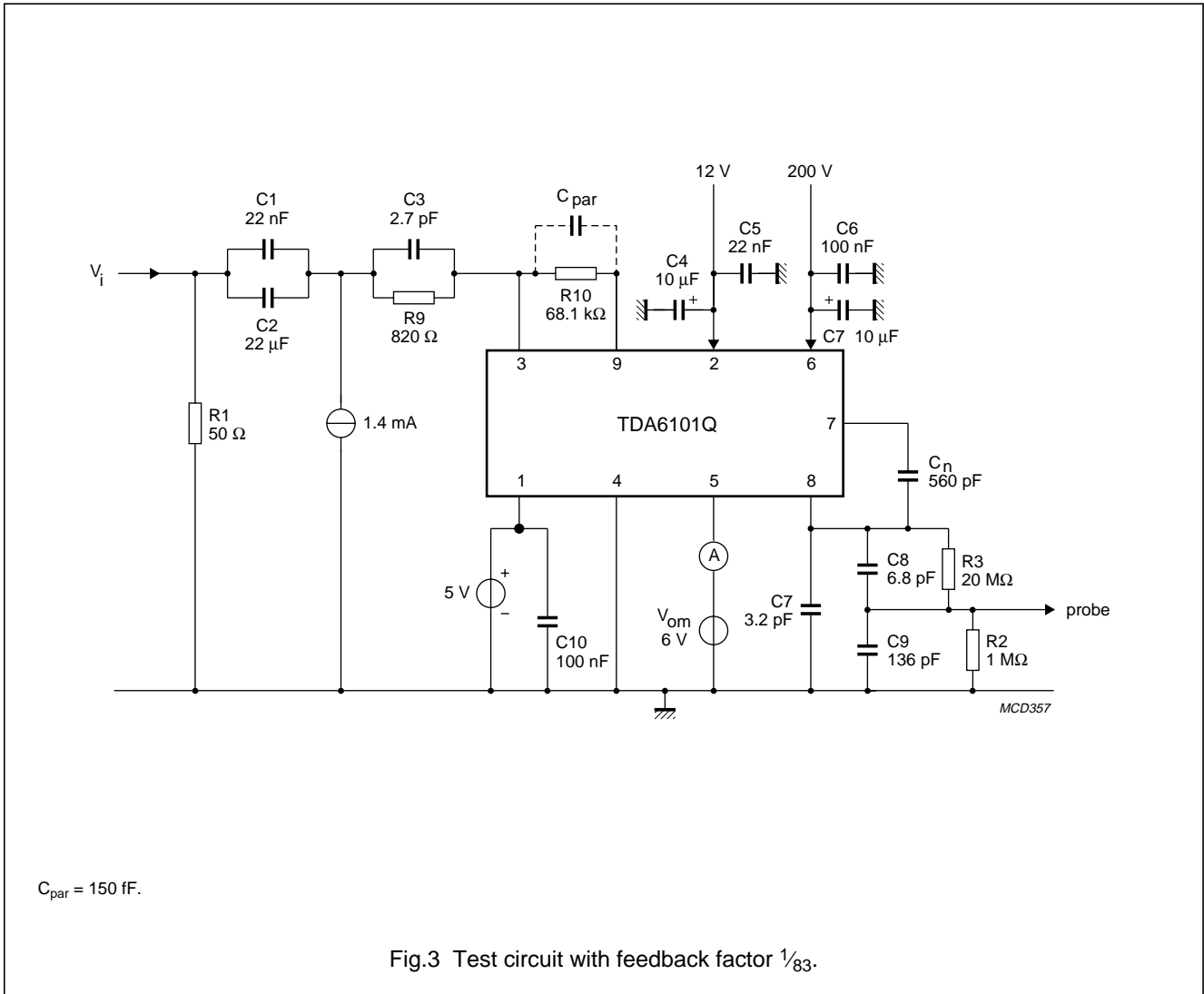

Video output amplifier

TDA6101Q

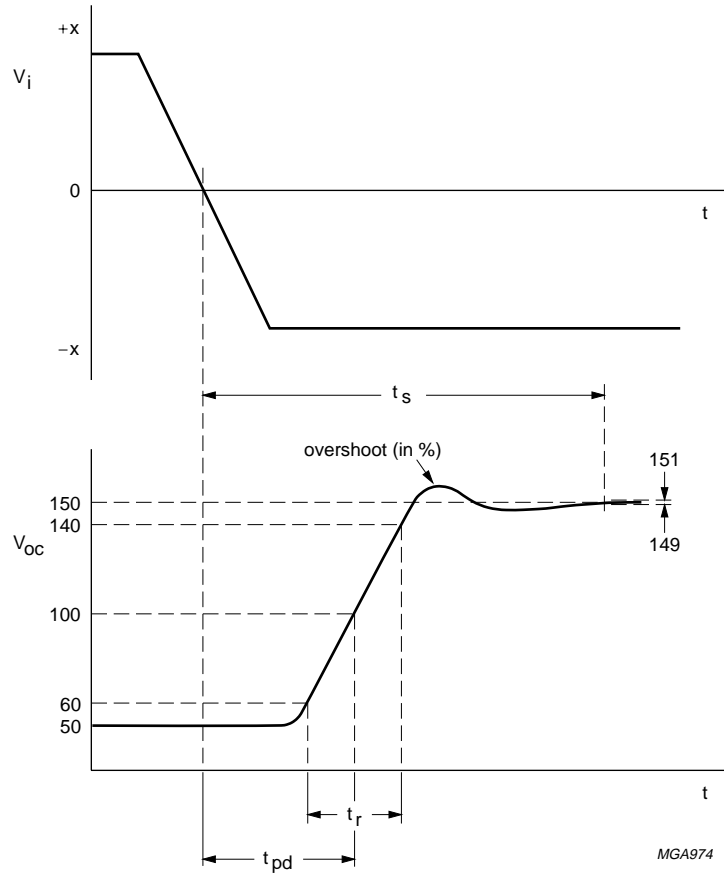

Fig.4 Output voltage (pin 8) rising edge as a function of the AC input signal.

Video output amplifier

TDA6101Q

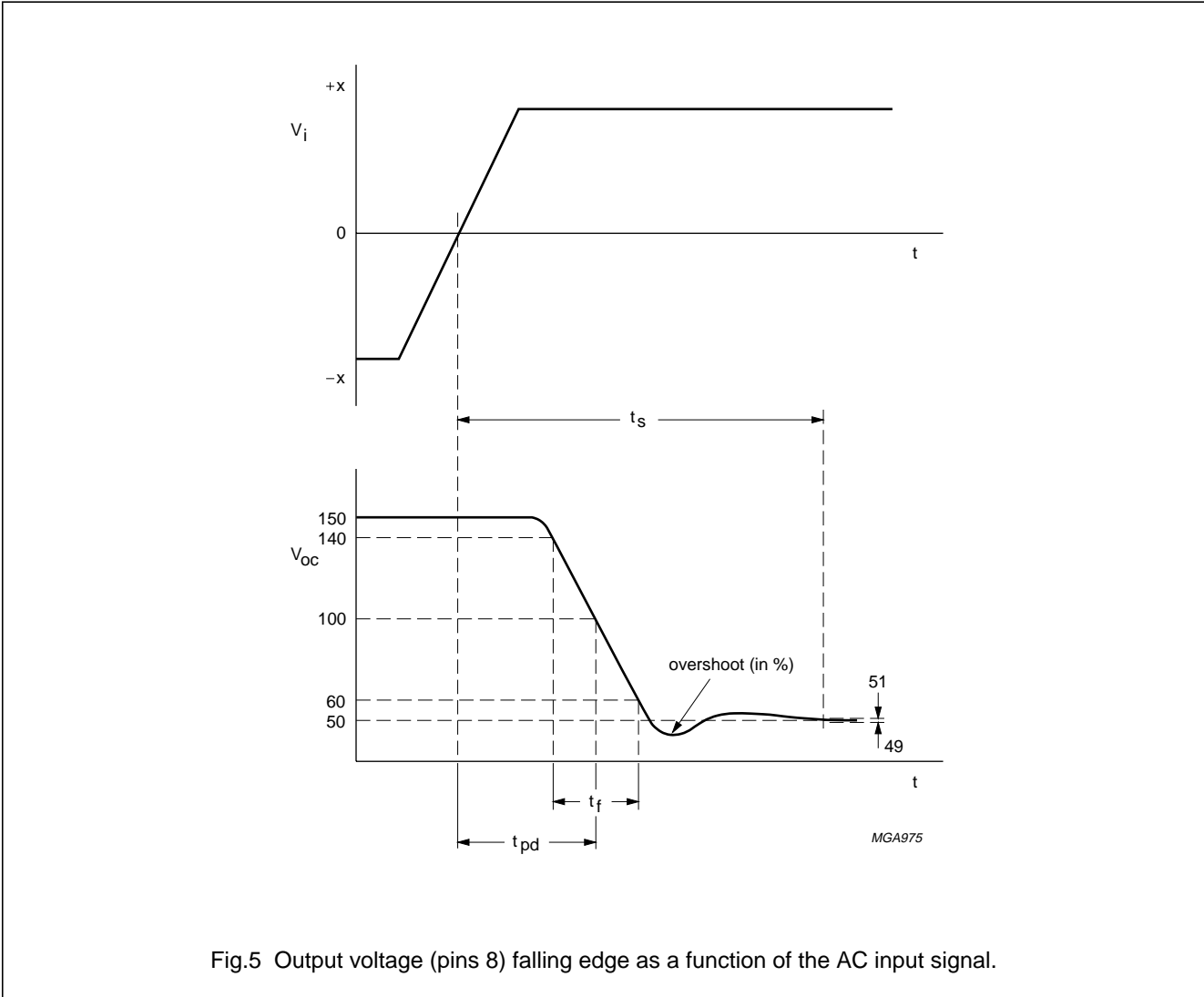

Fig.5 Output voltage (pins 8) falling edge as a function of the AC input signal.

Video output amplifier

TDA6101Q

TEST AND APPLICATION INFORMATION**Dissipation**

Regarding dissipation, distinction must first be made between static dissipation (independent of frequency) and dynamic dissipation (proportional to frequency).

The static dissipation of the TDA6101Q is due to high and low voltage supply currents and load currents in the feedback network and CRT.

The static dissipation equals:

$$P_{\text{stat}} = V_{\text{DDL}} \times I_{\text{DDL}} + V_{\text{DDH}} \times I_{\text{DDH}} + V_{\text{oc}} \times I_{\text{oc}} - V_{\text{fb}} \times \left(\frac{V_{\text{fb}}}{R_{\text{fb}}} \right)$$

R_{fb} = value of feedback resistor.

I_{oc} = DC value of cathode current.

The dynamic dissipation equals:

$$P_{\text{dyn}} = V_{\text{DDH}} \times (C_{\text{L}} + C_{\text{fb}} + C_{\text{int}}) \times f_{\text{i}} \times V_{\text{o(p-p)}} \times \delta$$

C_{L} = load capacitance.

C_{fb} = feedback capacitance (≈ 150 fF).

C_{int} = internal load capacitance (≈ 4 pF).

f_{i} = input frequency.

$V_{\text{o(p-p)}}$ = output voltage (peak-to-peak value).

δ = non-blanking duty-cycle (≈ 0.8).

The IC must be mounted on the picture tube base print to minimize the load capacitance (C_{L}).

Video output amplifier

TDA6101Q

PACKAGE OUTLINE

DBS9MPF: plastic DIL-bent-SIL medium power package with fin; 9 leads

SOT111-1

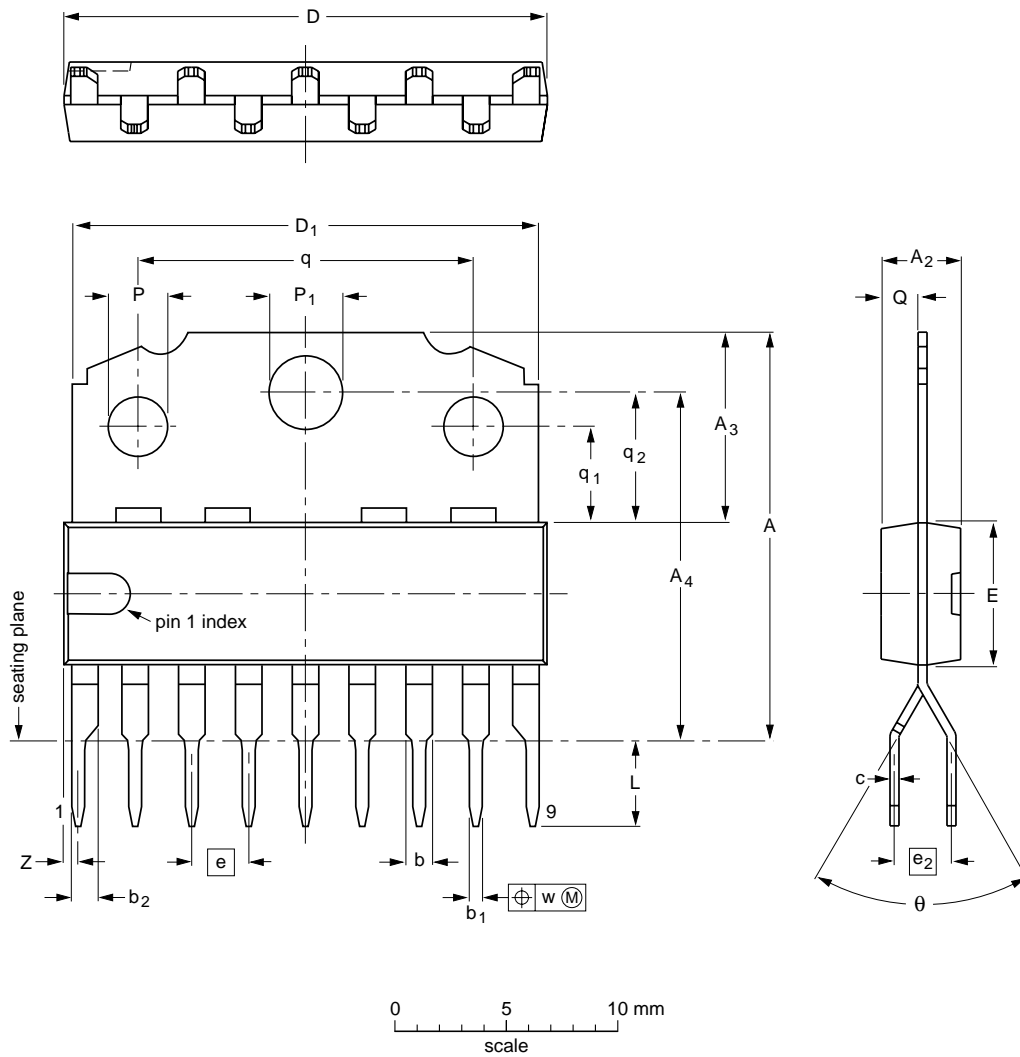

DIMENSIONS (mm are the original dimensions)

UNIT	A	A ₂ max.	A ₃	A ₄	b	b ₁	b ₂	c	D ⁽¹⁾	D ₁	E ⁽¹⁾	e	e ₂	L	P	P ₁	Q	q	q ₁	q ₂	w	Z ⁽¹⁾ max.	θ
mm	18.5 17.8	3.7	8.7 8.0	15.5 15.1	1.40 1.14	0.67 0.50	1.40 1.14	0.48 0.38	21.8 21.4	21.4 20.7	6.48 6.20	2.54	2.54	3.9 3.4	2.75 2.50	3.4 3.2	1.75 1.55	15.1 14.9	4.4 4.2	5.9 5.7	0.25	1.0	65° 55°

Note

1. Plastic or metal protrusions of 0.25 mm maximum per side are not included.

OUTLINE VERSION	REFERENCES			EUROPEAN PROJECTION	ISSUE DATE
	IEC	JEDEC	EIAJ		
SOT111-1					92-11-17 95-03-11

Video output amplifier

TDA6101Q

SOLDERING**Plastic single in-line packages**

BY DIP OR WAVE

The maximum permissible temperature of the solder is 260 °C; this temperature must not be in contact with the joint for more than 5 s. The total contact time of successive solder waves must not exceed 5 s.

The device may be mounted up to the seating plane, but the temperature of the plastic body must not exceed the specified storage maximum. If the printed-circuit board has been pre-heated, forced cooling may be necessary immediately after soldering to keep the temperature within the permissible limit.

REPAIRING SOLDERED JOINTS

Apply the soldering iron below the seating plane (or not more than 2 mm above it). If its temperature is below 300 °C, it must not be in contact for more than 10 s; if between 300 and 400 °C, for not more than 5 s.

DEFINITIONS

Data sheet status	
Objective specification	This data sheet contains target or goal specifications for product development.
Preliminary specification	This data sheet contains preliminary data; supplementary data may be published later.
Product specification	This data sheet contains final product specifications.
Limiting values	
Limiting values given are in accordance with the Absolute Maximum Rating System (IEC 134). Stress above one or more of the limiting values may cause permanent damage to the device. These are stress ratings only and operation of the device at these or at any other conditions above those given in the Characteristics sections of the specification is not implied. Exposure to limiting values for extended periods may affect device reliability.	
Application information	
Where application information is given, it is advisory and does not form part of the specification.	

LIFE SUPPORT APPLICATIONS

These products are not designed for use in life support appliances, devices, or systems where malfunction of these products can reasonably be expected to result in personal injury. Philips customers using or selling these products for use in such applications do so at their own risk and agree to fully indemnify Philips for any damages resulting from such improper use or sale.

Video output amplifier

TDA6101Q

NOTES

Video output amplifier

TDA6101Q

NOTES

Philips Semiconductors – a worldwide company

Argentina: IEROD, Av. Juramento 1992 - 14.b, (1428)
BUENOS AIRES, Tel. (541)786 7633, Fax. (541)786 9367

Australia: 34 Waterloo Road, NORTH RYDE, NSW 2113,
Tel. (02)805 4455, Fax. (02)805 4466

Austria: Triester Str. 64, A-1101 WIEN, P.O. Box 213,
Tel. (01)60 101-1236, Fax. (01)60 101-1211

Belgium: Postbus 90050, 5600 PB EINDHOVEN, The Netherlands,
Tel. (31)40 783 749, Fax. (31)40 788 399

Brazil: Rua do Rocio 220 - 5th floor, Suite 51,
CEP: 04552-903-SÃO PAULO-SP, Brazil.
P.O. Box 7383 (01064-970).
Tel. (011)821-2333, Fax. (011)829-1849

Canada: PHILIPS SEMICONDUCTORS/COMPONENTS:
Tel. (800) 234-7381, Fax. (708) 296-8556

Chile: Av. Santa Maria 0760, SANTIAGO,
Tel. (02)773 816, Fax. (02)777 6730

Colombia: IPRELENZO LTDA, Carrera 21 No. 56-17,
77621 BOGOTA, Tel. (571)249 7624/(571)217 4609,
Fax. (571)217 4549

Denmark: Prags Boulevard 80, PB 1919, DK-2300 COPENHAGEN S,
Tel. (032)88 2636, Fax. (031)57 1949

Finland: Sinikalliontie 3, FIN-02630 ESPOO,
Tel. (9)0-50261, Fax. (9)0-520971

France: 4 Rue du Port-aux-Vins, BP317,
92156 SURESNES Cedex,
Tel. (01)4099 6161, Fax. (01)4099 6427

Germany: P.O. Box 10 63 23, 20043 HAMBURG,
Tel. (040)3296-0, Fax. (040)3296 213.

Greece: No. 15, 25th March Street, GR 17778 TAVROS,
Tel. (01)4894 339/4894 911, Fax. (01)4814 240

Hong Kong: PHILIPS HONG KONG Ltd., 15/F Philips Ind. Bldg.,
24-28 Kung Yip St., KWAI CHUNG, N.T.,
Tel. (852)424 5121, Fax. (852)480 6960/480 6009

India: Philips INDIA Ltd, Shivsagar Estate, A Block,
Dr. Annie Besant Rd. Worli, Bombay 400 018
Tel. (022)4938 541, Fax. (022)4938 722

Indonesia: Philips House, Jalan H.R. Rasuna Said Kav. 3-4,
P.O. Box 4252, JAKARTA 12950,
Tel. (021)5201 122, Fax. (021)5205 189

Ireland: Newstead, Clonskeagh, DUBLIN 14,
Tel. (01)640 000, Fax. (01)640 200

Italy: PHILIPS SEMICONDUCTORS S.r.l.,
Piazza IV Novembre 3, 20124 MILANO,
Tel. (0039)2 6752 2531, Fax. (0039)2 6752 2557

Japan: Philips Bldg 13-37, Kohnan2-chome, Minato-ku, TOKYO 108,
Tel. (03)3740 5028, Fax. (03)3740 0580

Korea: (Republic of) Philips House, 260-199 Itaewon-dong,
Yongsan-ku, SEOUL, Tel. (02)794-5011, Fax. (02)798-8022

Malaysia: No. 76 Jalan Universiti, 46200 PETALING JAYA,
SELANGOR, Tel. (03)750 5214, Fax. (03)757 4880

Mexico: 5900 Gateway East, Suite 200, EL PASO, TX 79905,
Tel. 9-5(800)234-7381, Fax. (708)296-8556

Netherlands: Postbus 90050, 5600 PB EINDHOVEN, Bldg. VB
Tel. (040)783749, Fax. (040)788399

New Zealand: 2 Wagener Place, C.P.O. Box 1041, AUCKLAND,
Tel. (09)849-4160, Fax. (09)849-7811

Norway: Box 1, Manglerud 0612, OSLO,
Tel. (022)74 8000, Fax. (022)74 8341

Pakistan: Philips Electrical Industries of Pakistan Ltd.,
Exchange Bldg. ST-2/A, Block 9, KDA Scheme 5, Clifton,
KARACHI 75600, Tel. (021)587 4641-49,
Fax. (021)577035/5874546.

Philippines: PHILIPS SEMICONDUCTORS PHILIPPINES Inc.,
106 Valero St. Salcedo Village, P.O. Box 2108 MCC, MAKATI,
Metro MANILA, Tel. (02)810 0161, Fax. (02)817 3474

Portugal: PHILIPS PORTUGUESA, S.A.,
Rua dr. António Loureiro Borges 5, Arquiparque - Miraflores,
Apartado 300, 2795 LINDA-A-VELHA,
Tel. (01)4163160/4163333, Fax. (01)4163174/4163366.

Singapore: Lorong 1, Toa Payoh, SINGAPORE 1231,
Tel. (65)350 2000, Fax. (65)251 6500

South Africa: S.A. PHILIPS Pty Ltd.,
195-215 Main Road Martindale, 2092 JOHANNESBURG,
P.O. Box 7430 Johannesburg 2000,
Tel. (011)470-5911, Fax. (011)470-5494.

Spain: Balmes 22, 08007 BARCELONA,
Tel. (03)301 6312, Fax. (03)301 42 43

Sweden: Kottbygatan 7, Akalla. S-164 85 STOCKHOLM,
Tel. (0)8-632 2000, Fax. (0)8-632 2745

Switzerland: Allmendstrasse 140, CH-8027 ZÜRICH,
Tel. (01)488 2211, Fax. (01)481 77 30

Taiwan: PHILIPS TAIWAN Ltd., 23-30F, 66, Chung Hsiao West
Road, Sec. 1. Taipei, Taiwan ROC, P.O. Box 22978,
TAIPEI 100, Tel. (02)388 7666, Fax. (02)382 4382.

Thailand: PHILIPS ELECTRONICS (THAILAND) Ltd.,
209/2 Sanpavuth-Bangna Road Prakanong,
Bangkok 10260, THAILAND,
Tel. (662)398-0141, Fax. (662)398-3319.

Turkey: Talatpasa Cad. No. 5, 80640 GÜLTEPE/ISTANBUL,
Tel. (0212)279 2770, Fax. (0212)282 6707

United Kingdom: Philips Semiconductors LTD.,
276 Bath Road, Hayes, MIDDLESEX UB3 5BX,
Tel. (0181)730-5000, Fax. (0181)754-8421

United States: 811 East Arques Avenue, SUNNYVALE,
CA 94088-3409, Tel. (800)234-7381, Fax. (708)296-8556

Uruguay: Coronel Mora 433, MONTEVIDEO,
Tel. (02)70-4044, Fax. (02)92 0601

Internet: <http://www.semiconductors.philips.com/ps/>

For all other countries apply to: Philips Semiconductors,
International Marketing and Sales, Building BE-p,
P.O. Box 218, 5600 MD, EINDHOVEN, The Netherlands,
Telex 35000 phtncn, Fax. +31-40-724825

SCD38

© Philips Electronics N.V. 1994

All rights are reserved. Reproduction in whole or in part is prohibited without the prior written consent of the copyright owner.

The information presented in this document does not form part of any quotation or contract, is believed to be accurate and reliable and may be changed without notice. No liability will be accepted by the publisher for any consequence of its use. Publication thereof does not convey nor imply any license under patent- or other industrial or intellectual property rights.

Printed in The Netherlands

533061/1500/02/pp16
Document order number:

Date of release: 1995 Feb 07
9397 747 50011

Philips Semiconductors



PHILIPS