



TDA7222A TDA7222AD

3V AM/FM ONE-CHIP RADIO

ADVANCE DATA

- BUILT-IN FM F/E, AM/FM IF AND FM MPX
- AM DETECTOR COIL AND IF COUPLING CAPACITOR ARE NOT NEEDED
- COMPACT PACKAGE : 24-Pin Shrink
- OPERATING SUPPLY VOLTAGE RANGE
 $V_{CC (opr)} = 1.8 \text{ to } 7.0\text{V}$ ($T_A = 25^\circ\text{C}$)
- LED DRIVE CIRCUIT FOR TUNING INDICATION

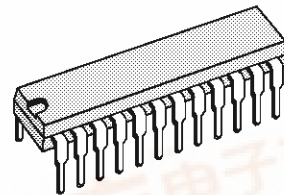

SHRINK DIP24
(Plastic Package)

ORDER CODE : TDA7222A

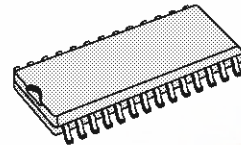

SO28
(Plastic Micropackage)

ORDER CODE : TDA7222AD

DESCRIPTION

TDA7222A and TDA7222AD are AM/FM chip tuner ICs, which are designed for portable radios and 3V headphone radios.

PIN CONNECTIONS

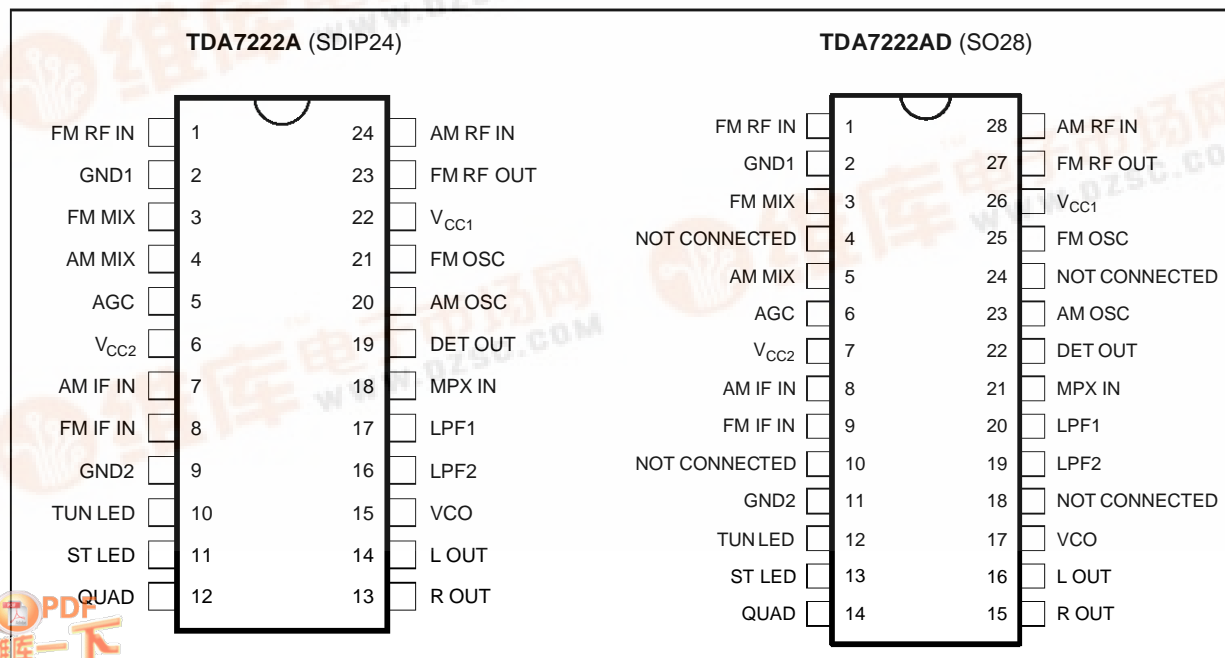

TDA7222A - TDA7222AD

BLOCK DIAGRAM

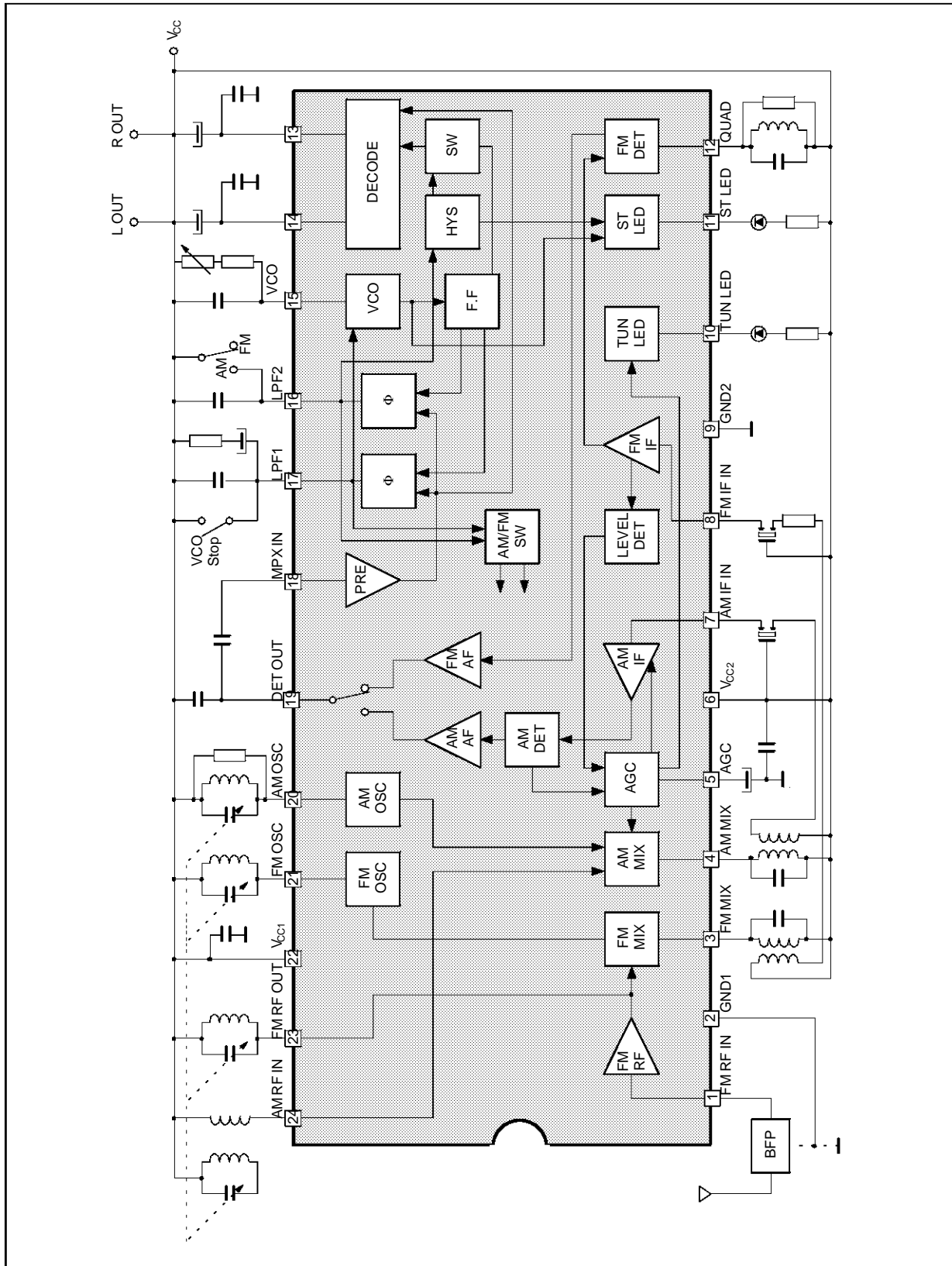

ABSOLUTE MAXIMUM RATINGS

Symbol	Parameter	Value	Unit
V _S	Supply Voltage	9	V
I _{LED}	LED Current	10	mA
V _{LED}	LED Voltage	10	V
T _{oper}	Operating Temperature	-20, +70	°C
T _{stg}	Storage Temperature	-55, +150	°C

7222A-01.TBL

RECOMMENDED OPERATING CONDITIONS

Symbol	Parameter	Value	Unit
V _S	Supply Voltage	1.8 to 7	V
T _{oper}	Operating Temperature	0, +70	°C

7222A-02.TBL

ELECTRICAL CHARACTERISTICS (unless otherwise specified)

T_A = 25°C, V_{CC} = 3V F/E : f = 83MHz, f_m = 1kHz
 FM IF : f = 10.7MHz, Δf = ± 22.5kHz, f_m = 1kHz
 AM : f = 1MHz, MOD = 30%, f_m = 1kHz
 MPX : f_m = 1kHz

Symbol	Parameter	Test Conditions	Min.	Typ.	Max.	Unit	
I _{CC} (FM)	Supply Current	V _{IN} = 0, FM mode		13.2	20	mA	
I _{CC} (AM)		V _{IN} = 0, AM mode		8.4	13.5	mA	
V _{IN} (lim)	F/E	Input Limiting Voltage	- 3dB limiting	10.0		dBμ	
V _{OSC}		Local OSC Voltage	f _{OSC} = 72.3MHz		105	mV _{RMS}	
V _{IN} (lim) IF	FM IF	Input Limiting Voltage	- 3dB limiting	40	46	53	dBμ
V _{OD}		Recovered Output Voltage	V _{IN} = 80dBμ	55	80	110	mV _{RMS}
S/N		Signal to Noise Ratio	V _{IN} = 80dBμ		70		dB
THD		Total Harmonic Distortion	V _{IN} = 80dBμ		0.4		%
AMR		AM Rejection Ratio	V _{IN} = 80dBμ		32		dB
V _L		Lamp ON Sensitivity	I _L = 1mA	45	51	56	dBμ
G _V		Gain	V _{IN} = 26dBμ	40	70	110	mV _{RMS}
V _{OD}	AM	Recovered Output Voltage	V _{IN} = 60dBμ	55	80	110	mV _{RMS}
S/N		Signal to Noise Ratio	V _{IN} = 60dBμ		42		dB
THD		Total Harmonic Distortion	V _{IN} = 60dBμ		1.0		%
V _L		Lamp ON Sensitivity	I _L = 1mA	20	25	30	dBμ
R ₁₉		Pin 19 Output Resistance	FM mode AM mode		0.75 12.75		kΩ kΩ
R _{IN}		Input Resistance		24		kΩ	
R _{OUT}		Output Resistance		5		kΩ	
V _{IN} (Max.) Stereo	MPX	Max. Composite Signal Input Voltage	L + R = 90%, P = 10% f _m = 1kHz, THD = 3%	350		mV _{RMS}	
Sep		Separation	f _m = 100Hz f _m = 1kHz f _m = 10kHz	L + R = 135mV _{RMS} P = 15mV _{RMS}	25	32 32 32	dB dB dB
THD Monaural		Total Harmonic Distortion (monaural)	V _{IN} = 150mV _{RMS}		0.2		%
THD Stereo		Total Harmonic Distortion (stereo)	L + R = 135mV _{RMS} P = 15mV _{RMS}		0.2		%
G _V (MPX)		Voltage Gain	V _{IN} = 150mV _{RMS}	-5	-3	-1	dB
C.B.		Channel Balance	V _{IN} = 150mV _{RMS}	-2	0	2	dB

7222A-03.TBL

APPLICATION CIRCUIT

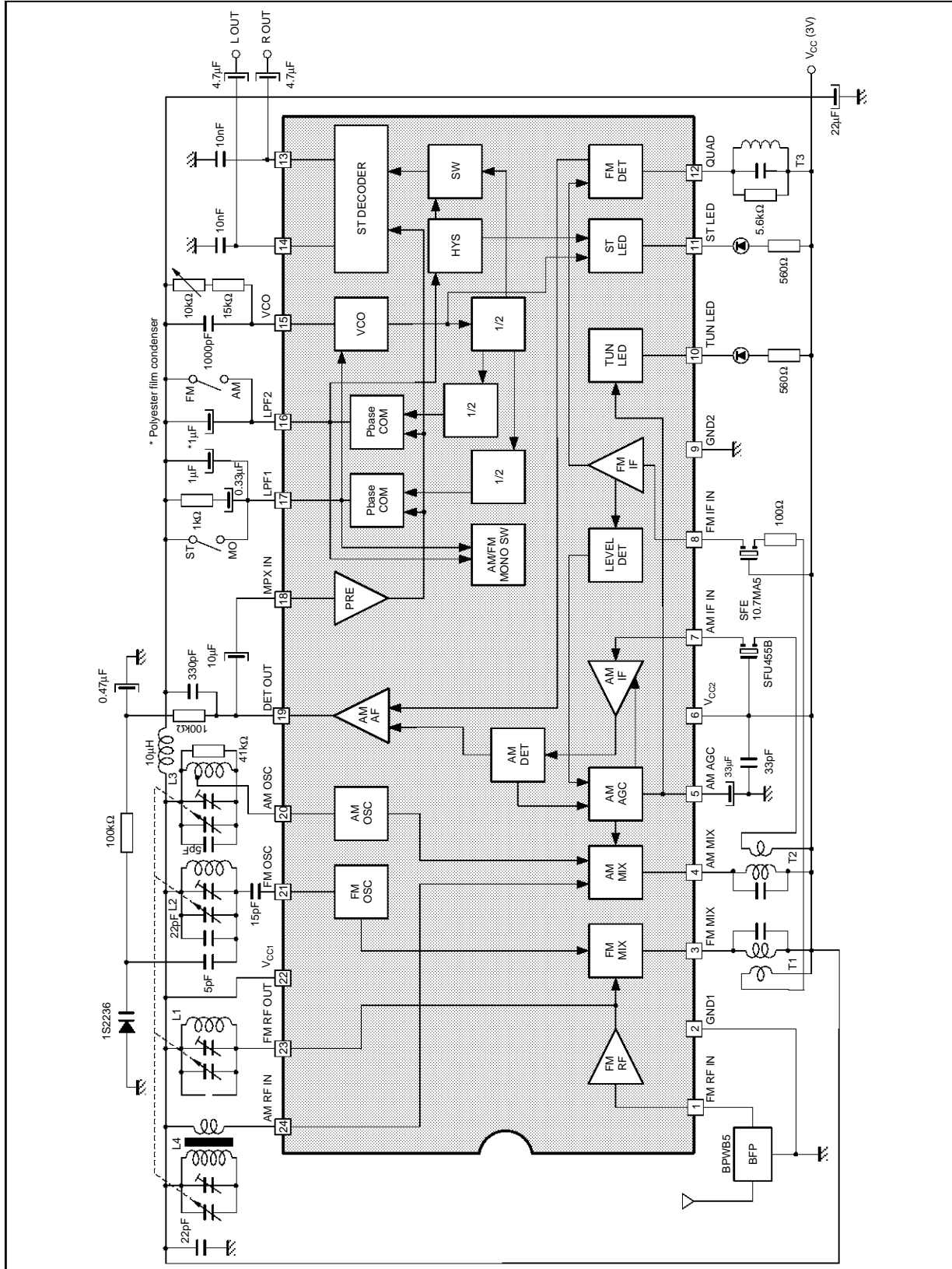

TDA7222A - TDA7222AD

PACKAGE MECHANICAL DATA (TDA7222A) 24 PINS - PLASTIC SHRINK DIP

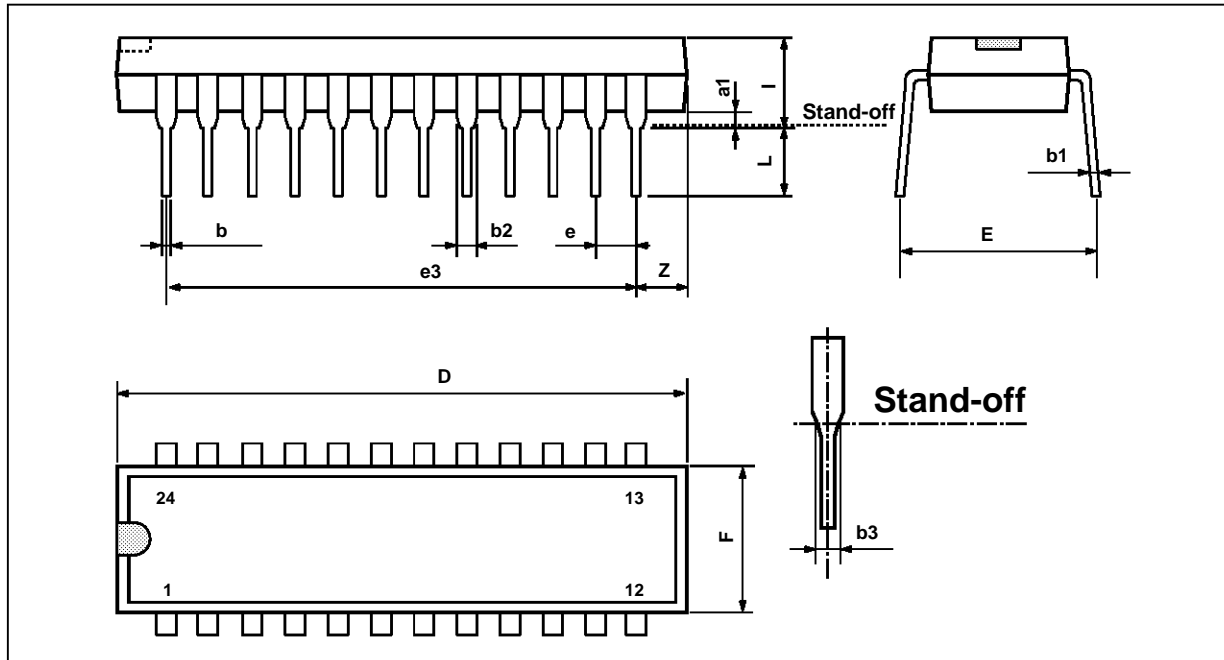

PM5DIP24.EPS

Dimensions	Millimeters			Inches		
	Min.	Typ.	Max.	Min.	Typ.	Max.
A		3.3			0.130	
a1	0.51			0.020		
b	0.35		0.59	0.014		0.023
b1	0.2		0.36	0.008		0.014
b2	0.75		1.42	0.030		0.056
b3	0.75			0.030		
D			23.11			0.910
E	7.95		9.73	0.313		0.383
e		1.778			0.070	
e3		19.558			0.770	
e4		7.62			0.300	
F			6.86			0.270
i			5.08			0.200
L	2.54			0.100		

SDIP24.TBL

PACKAGE MECHANICAL DATA (TDA7222AD)
 28 PINS - PLASTIC MICROPACKAGE (SO)

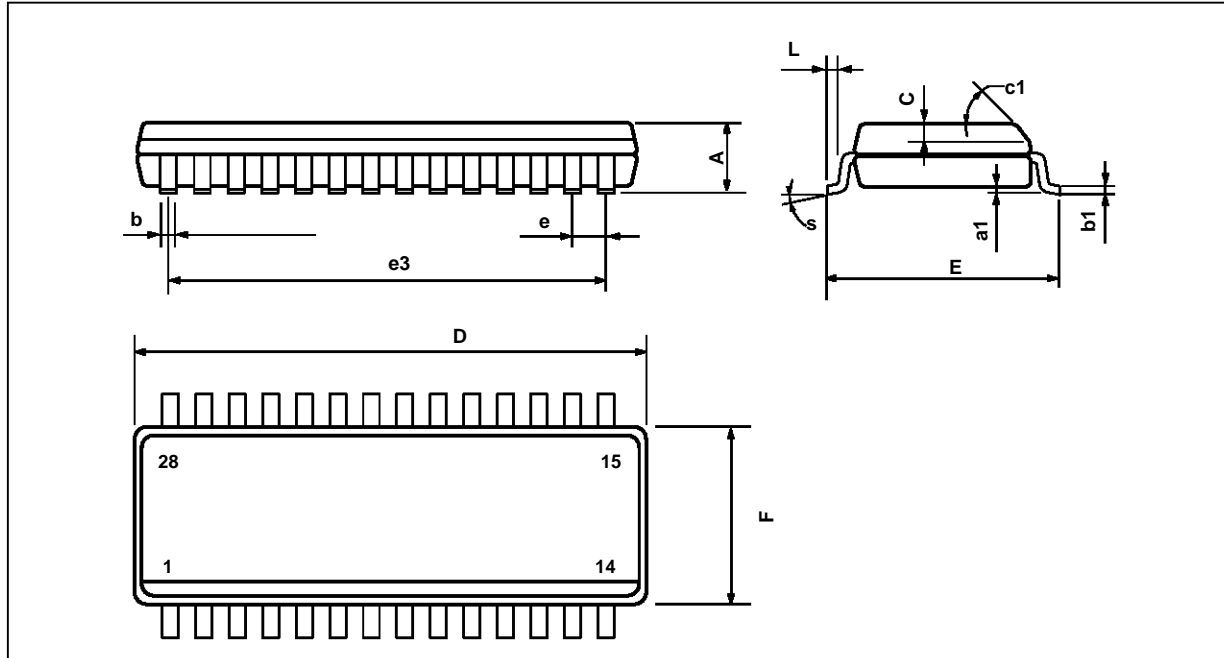

PM-SO28EPS

Dimensions	Millimeters			Inches		
	Min.	Typ.	Max.	Min.	Typ.	Max.
A			2.65			0.104
a1	0.1		0.3	0.004		0.012
b	0.35		0.49	0.014		0.019
b1	0.23		0.32	0.009		0.013
C		0.5			0.020	
c1	45° (typ.)					
D	17.7		18.1	0.697		0.713
E	10		10.65	0.394		0.419
e		1.27			0.050	
e3		16.51			0.65	
F	7.4		7.6	0.291		0.299
L	0.4		1.27	0.016		0.050
S	8° (max.)					

SO28.TBL

Information furnished is believed to be accurate and reliable. However, SGS-THOMSON Microelectronics assumes no responsibility for the consequences of use of such information nor for any infringement of patents or other rights of third parties which may result from its use. No licence is granted by implication or otherwise under any patent or patent rights of SGS-THOMSON Microelectronics. Specifications mentioned in this publication are subject to change without notice. This publication supersedes and replaces all information previously supplied. SGS-THOMSON Microelectronics products are not authorized for use as critical components in life support devices or systems without express written approval of SGS-THOMSON Microelectronics.

© 1995 SGS-THOMSON Microelectronics - All Rights Reserved

Purchase of I²C Components of SGS-THOMSON Microelectronics, conveys a license under the Philips I²C Patent. Rights to use these components in a I²C system, is granted provided that the system conforms to the I²C Standard Specifications as defined by Philips.

SGS-THOMSON Microelectronics GROUP OF COMPANIES

Australia - Brazil - China - France - Germany - Hong Kong - Italy - Japan - Korea - Malaysia - Malta - Morocco
 The Netherlands - Singapore - Spain - Sweden - Switzerland - Taiwan - Thailand - United Kingdom - U.S.A.