

8-Bit high-speed multiplying D/A converter

DAC08 Series

DESCRIPTION

The DAC08 series of 8-bit monolithic multiplying Digital-to-Analog Converters provide very high-speed performance coupled with low cost and outstanding applications flexibility.

Advanced circuit design achieves 70ns settling times with very low glitch and at low power consumption. Monotonic multiplying performance is attained over a wide 20-to-1 reference current range. Matching to within 1 LSB between reference and full-scale currents eliminates the need for full-scale trimming in most applications. Direct interface to all popular logic families with full noise immunity is provided by the high swing, adjustable threshold logic inputs.

Dual complementary outputs are provided, increasing versatility and enabling differential operation to effectively double the peak-to-peak output swing. True high voltage compliance outputs allow direct output voltage conversion and eliminate output op amps in many applications.

All DAC08 series models guarantee full 8-bit monotonicity and linearities as tight as 0.1% over the entire operating temperature range. Device performance is essentially unchanged over the $\pm 4.5V$ to $\pm 18V$ power supply range, with 37mW power consumption attainable at $\pm 5V$ supplies.

The compact size and low power consumption make the DAC08 attractive for portable and military aerospace applications.

FEATURES

- Fast settling output current—70ns
- Full-scale current prematched to ± 1 LSB
- Direct interface to TTL, CMOS, ECL, HTL, PMOS
- Relative accuracy to 0.1% maximum over temperature range
- High output compliance -10V to +18V
- True and complemented outputs
- Wide range multiplying capability
- Low FS current drift — $\pm 10\text{ppm}/^\circ\text{C}$
- Wide power supply range— $\pm 4.5V$ to $\pm 18V$
- Low power consumption—37mW at $\pm 5V$

APPLICATIONS

- 8-bit, $1\mu\text{s}$ A-to-D converters
- Servo-motor and pen drivers

PIN CONFIGURATIONS

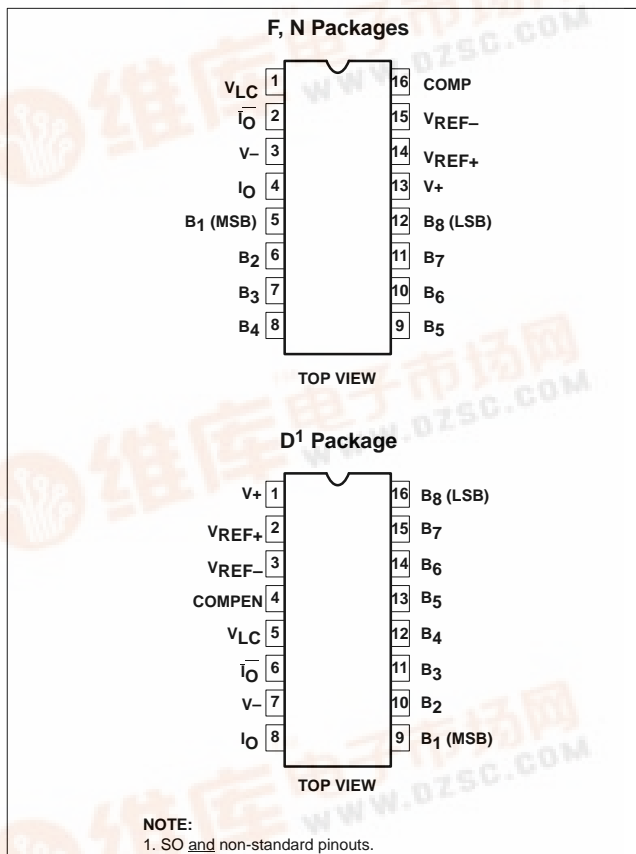

- Waveform generators
- Audio encoders and attenuators
- Analog meter drivers
- Programmable power supplies
- CRT display drivers
- High-speed modems
- Other applications where low cost, high speed and complete input/output versatility are required
- Programmable gain and attenuation
- Analog-Digital multiplication

8-Bit high-speed multiplying D/A converter

DAC08 Series

ORDERING INFORMATION

DESCRIPTION	TEMPERATURE RANGE	ORDER CODE	DWG #
16-Pin Hermetic Ceramic Dual In-Line Package (Cerdip)	-55°C to +125°C	DAC08F	0582B
16-Pin Hermetic Ceramic Dual In-Line Package (Cerdip)	-55°C to +125°C	DAC08AF	0582B
16-Pin Plastic Dual In-Line Package (DIP)	0 to +70°C	DAC08CN	0406C
16-Pin Hermetic Ceramic Dual In-Line Package (Cerdip)	0 to +70°C	DAC08CF	0582B
16-Pin Plastic Dual In-Line Package (DIP)	0 to +70°C	DAC08EN	0406C
16-Pin Hermetic Ceramic Dual In-Line Package (Cerdip)	0 to +70°C	DAC08EF	0582B
16-Pin Plastic Small Outline (SO) Package	0 to +70°C	DAC08ED	0005D
16-Pin Plastic Dual In-Line Package (DIP)	0 to +70°C	DAC08HN	0406C

BLOCK DIAGRAM

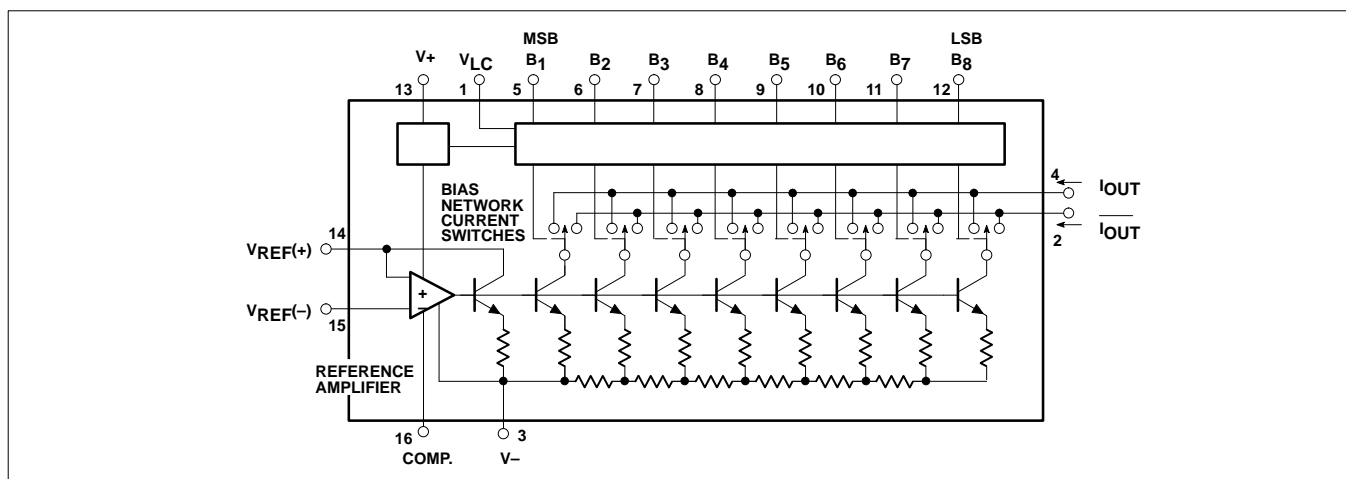

ABSOLUTE MAXIMUM RATINGS

SYMBOL	PARAMETER	RATING	UNIT
V+ to V-	Power supply voltage	36	V
V5-V12	Digital input voltage	V- to V- plus 36V	
VLC	Logic threshold control	V- to V+	
V0	Applied output voltage	V- to +18	V
I14	Reference current	5.0	mA
V14, V15	Reference amplifier inputs	V _{EE} to V _{CC}	
P _D	Maximum power dissipation T _A =25°C (still-air) ¹		
	F package	1190	mW
	N package	1450	mW
	D package	1090	mW
T _{SOLD}	Lead soldering temperature (10sec max)	300	°C
T _A	Operating temperature range		
	DAC08, DAC08A	-55 to +125	°C
	DAC08C, E, H	0 to +70	°C
T _{STG}	Storage temperature range	-65 to +150	°C

NOTES:

- Derate above 25°C, at the following rates:
 F package at 9.5mW/°C
 N package at 11.6mW/°C
 D package at 8.7mW/°C

8-Bit high-speed multiplying D/A converter

DAC08 Series

DC ELECTRICAL CHARACTERISTICS

Pin 3 must be at least 3V more negative than the potential to which R₁₅ is returned. V_{CC}=±15V, I_{REF}=2.0mA. Output characteristics refer to both I_{OUT} and I_{OUT} unless otherwise noted. DAC08C, E, H: T_A=0°C to 70°C DAC08/08A: T_A=-55°C to 125°C

SYMBOL	PARAMETER	TEST CONDITIONS	DAC08C			DAC08E DAC08			UNIT
			Min	Typ	Max	Min	Typ	Max	
	Resolution		8	8	8	8	8	8	Bits
	Monotonicity		8	8	8	8	8	8	Bits
	Relative accuracy	Over temperature range			±0.39			±0.19	%FS
	Differential non-linearity				±0.78			±0.39	%FS
TCI _{FS}	Full-scale tempco			±10			±10		ppm/°C
V _{OC}	Output voltage compliance	Full-scale current change < 1/2LSB	-10		+18	-10		+18	V
I _{FS4}	Full-scale current	V _{REF} =10.000V, R ₁₄ , R ₁₅ =5.000kΩ	1.94	1.99	2.04	1.94	1.99	2.04	mA
I _{FSS}	Full-scale symmetry	I _{FS4} -I _{FS2}		±2.0	±16		±1.0	±8.0	μA
I _{ZS}	Zero-scale current			0.2	4.0		0.2	2.0	μA
I _{FSR}	Full-scale output current range	R ₁₄ , R ₁₅ =5.000kΩ V _{REF} =+15.0V, V ₋ =-10V V _{REF} =+25.0V, V ₋ =-12V	2.1 4.2			2.1 4.2			mA
V _{IL} V _{IH}	Logic input levels Low High	V _{LC} =0V	2.0		0.8	2.0		0.8	V
I _{IL} I _{IH}	Logic input current Low High	V _{LC} =0V V _{IN} =-10V to +0.8V V _{IN} =2.0V to 18V		-2.0 0.002	-10 10		-2.0 0.002	-10 10	μA
V _{IS}	Logic input swing	V ₋ =-15V	-10		+18	-10		+18	V
V _{THR}	Logic threshold range	V _S =±15V	-10		+13.5	-10		+13.5	V
I ₁₅	Reference bias current			-1.0	-3.0		-1.0	-3.0	μA
di/dt	Reference input slew rate		4.0	8.0		4.0	8.0		mA/μs
PSSI _{FS+} PSI _{FS-}	Power supply sensitivity Positive Negative	I _{REF} =1mA V ₊ =4.5 to 5.5V, V ₋ =-15V; V ₊ =13.5 to 16.5V, V ₋ =-15V V ₋ =-4.5 to -5.5V, V ₊ =+15V; V ₋ =-13.5 to -16.5, V ₊ =+15V		0.0003 0.002	0.01 0.01		0.0003 0.002	0.01 0.01	%FS/%VS
I ₊ I ₋	Power supply current Positive Negative	V _S =±5V, I _{REF} =1.0mA		3.1 -4.3	3.8 -5.8		3.1 -4.3	3.8 -5.8	mA
I ₊ I ₋	Positive Negative	V _S =+5V, -15V, I _{REF} =2.0mA		3.1 -7.1	3.8 -7.8		3.1 -7.1	3.8 -7.8	
I ₊ I ₋	Positive Negative	V _S =±15V, I _{REF} =2.0mA		3.2 -7.2	3.8 -7.8		3.2 -7.2	3.8 -7.8	
P _D	Power dissipation	±5V, I _{REF} =1.0mA +5V, -15V, I _{REF} =2.0mA ±15V, I _{REF} =2.0mA		37 122 156	48 136 174		37 122 156	48 136 174	mW

8-Bit high-speed multiplying D/A converter

DAC08 Series

DC ELECTRICAL CHARACTERISTICS (Continued)

Pin 3 must be at least 3V more negative than the potential to which R15 is returned. $V_{CC} = +15V$, $I_{REF} = 2.0mA$. Output characteristics refer to both I_{OUT} and $\overline{I_{OUT}}$, unless otherwise noted. DAC08C, E, H: $T_A = 0^\circ C$ to $70^\circ C$. DAC08/08A: $T_A = -55^\circ C$ to $125^\circ C$.

SYMBOL	PARAMETER	TEST CONDITIONS	DAC08H DAC08A			UNIT
			Min	Typ	Max	
	Resolution		8	8	8	Bits
	Monotonicity		8	8	8	Bits
	Relative accuracy	Over temperature range			± 0.1	%FS
	Differential non-linearity				± 0.19	%FS
TCI_{FS}	Full-scale tempco			± 10	± 50	ppm/ $^\circ C$
V_{OC}	Output voltage compliance	Full-scale current change 1/2LSB	-10		+18	V
I_{FS4}	Full-scale current	$V_{REF}=10.000V$, R_{14} , $R_{15}=5.000k\Omega$	1.984	1.992	2.000	mA
I_{FSS}	Full-scale symmetry	$I_{FS4}-I_{FS2}$		± 1.0	± 4.0	μA
I_{ZS}	Zero-scale current			0.2	1.0	μA
I_{FSR}	Full-scale output current range	R_{14} , $R_{15}=5.000k\Omega$ $V_{REF}=+15.0V$, $V=-10V$ $V_{REF}=+25.0V$, $V=-12V$	2.1 4.2			mA
V_{IL} V_{IH}	Logic input levels Low High	$V_{LC}=0V$	2.0		0.8	V
I_{IL} I_{IH}	Logic input current Low High	$V_{LC}=0V$ $V_{IN}=-10V$ to $+0.8V$ $V_{IN}=2.0V$ to $18V$		-2.0 0.002	-10 10	μA
V_{IS}	Logic input swing	$V=-15V$	-10		+18	V
V_{THR}	Logic threshold range	$V_S=\pm 15V$	-10		+13.5	V
I_{15}	Reference bias current			-1.0	-3.0	μA
dl/dt	Reference input slew rate		4.0	8.0		mA/ μs
$PSSI_{FS+}$ PSI_{FS-}	Power supply sensitivity Positive Negative	$I_{REF}=1mA$ $V+=4.5$ to $5.5V$, $V=-15V$; $V+=13.5$ to $16.5V$, $V=-15V$ $V=-4.5$ to $-5.5V$, $V+=+15V$; $V=-13.5$ to $-16.5V$, $V+=+15V$		0.0003 0.002	0.01 0.01	%FS/%VS
$I+$ $I-$	Power supply current Positive Negative	$V_S=\pm 5V$, $I_{REF}=1.0mA$		3.1 -4.3	3.8 -5.8	mA
$I+$ $I-$	Positive Negative	$V_S=+5V$, $-15V$, $I_{REF}=2.0mA$		3.1 -7.1	3.8 -7.8	
$I+$ $I-$	Positive Negative	$V_S=\pm 15V$, $I_{REF}=2.0mA$		3.2 -7.2	3.8 -7.8	
P_D	Power dissipation	$\pm 5V$, $I_{REF}=1.0mA$ $+5V$, $-15V$, $I_{REF}=2.0mA$ $\pm 15V$, $I_{REF}=2.0mA$		37 122 156	48 136 174	mW

8-Bit high-speed multiplying D/A converter

DAC08 Series

AC ELECTRICAL CHARACTERISTICS

SYMBOL	PARAMETER	TEST CONDITIONS	DAC08C			DAC08E DAC08			DAC08H DAC08A			UNIT
			Min	Typ	Max	Min	Typ	Max	Min	Typ	Max	
t_s	Settling time	To $\pm 1/2$ LSB, all bits switched on or off, $T_A=25^\circ\text{C}$		70	135		70	135		70	135	ns
t_{PLH}	Low-to-High	$T_A=25^\circ\text{C}$, each bit.										ns
t_{PHL}	High-to-Low	All bits switched	35	60		35	60		35	60		

TEST CIRCUITS

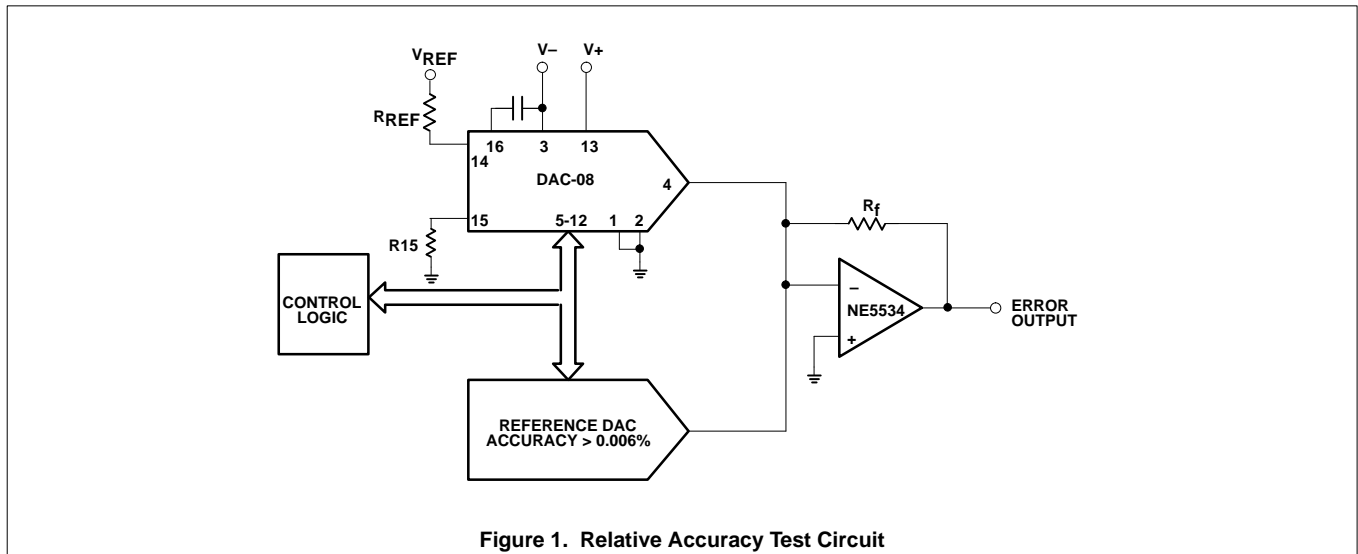

Figure 1. Relative Accuracy Test Circuit

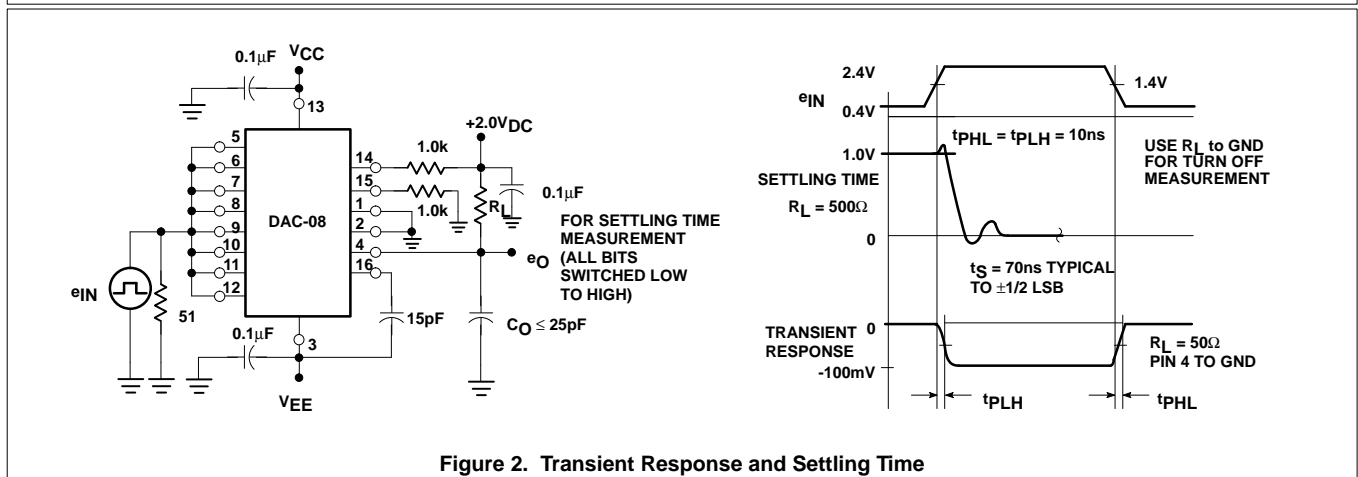

Figure 2. Transient Response and Settling Time

8-Bit high-speed multiplying D/A converter

DAC08 Series

TEST CIRCUITS (Continued)

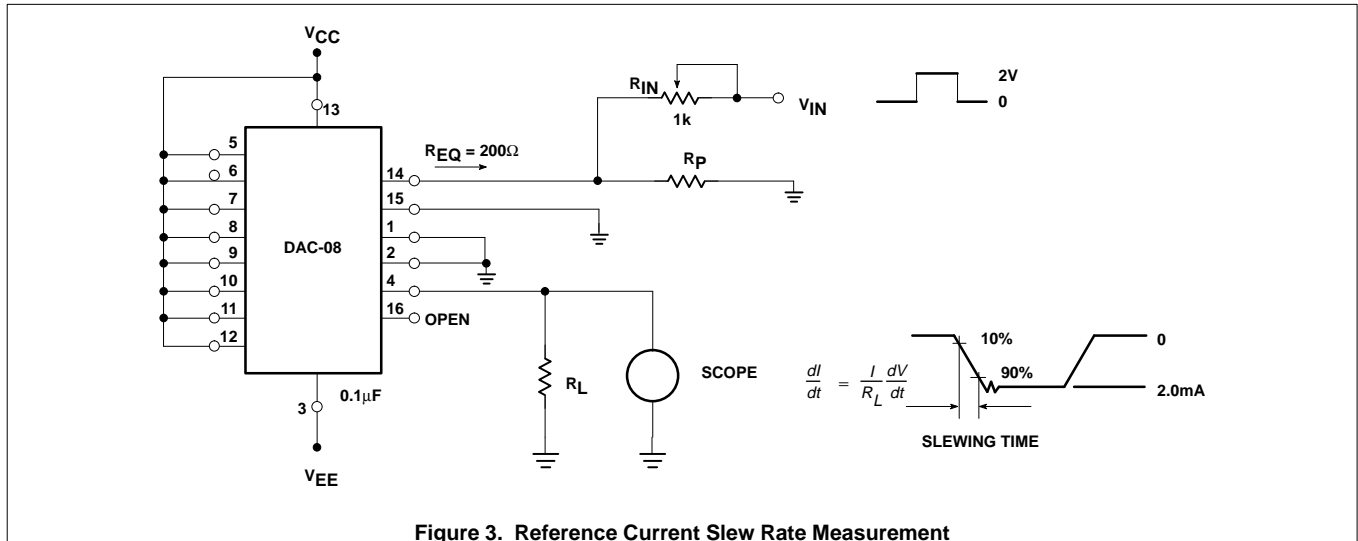

Figure 3. Reference Current Slew Rate Measurement

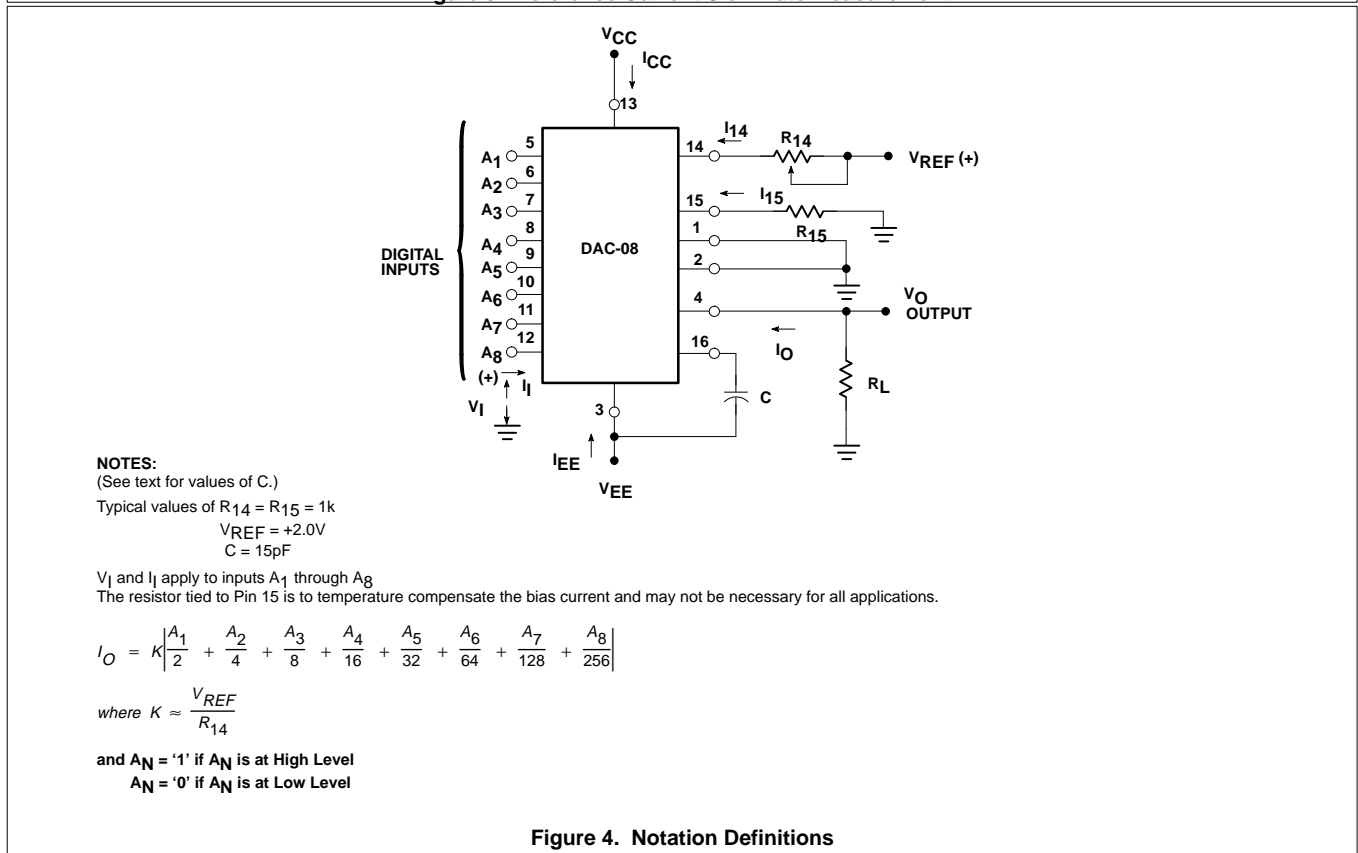

Figure 4. Notation Definitions

8-Bit high-speed multiplying D/A converter

DAC08 Series

TYPICAL PERFORMANCE CHARACTERISTICS

Output Current vs Output Voltage (Output Voltage Compliance)

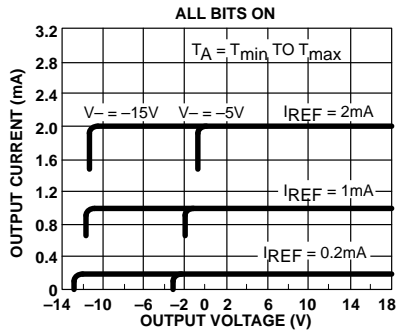

Fast Pulsed Reference Operation

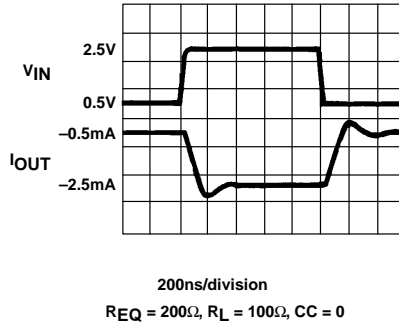

True and Complementary Output Operation

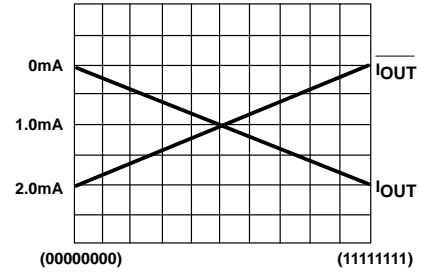

Full-Scale Settling Time

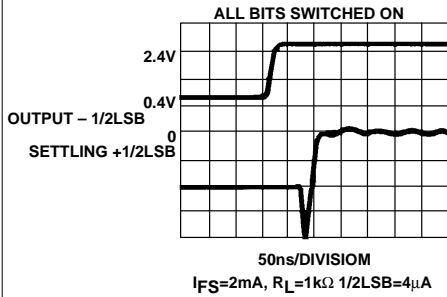

LSB Switching

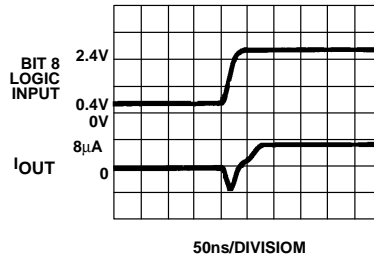

Full-Scale Current vs Reference Current

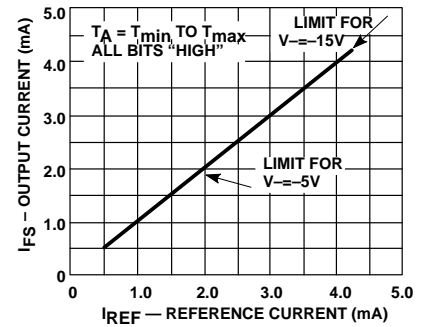

LSB Propagation Delay vs IFS

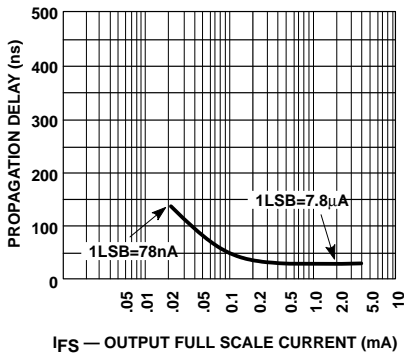

Reference Input Frequency Response

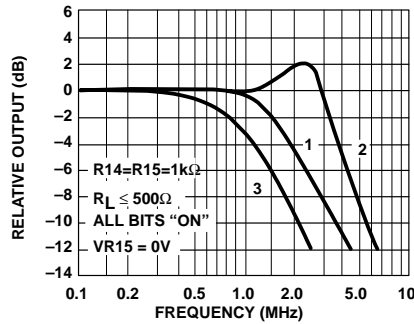

NOTES:

- Curve 1: CC = 15pF, VIN = 2.0Vp-p centered at +1.0V
- Curve 1: CC = 15pF, VIN = 5m0Vp-p centered at +200mV
- Curve 1: CC = 15pF, VIN = 100m0Vp-p centered at 0V and applied through 50Ω connected to Pin 14. +2.0V applied to R14.

8-Bit high-speed multiplying D/A converter

DAC08 Series

TYPICAL PERFORMANCE CHARACTERISTICS (Continued)

**Reference AMP Common-Mode Range
All Bits On**

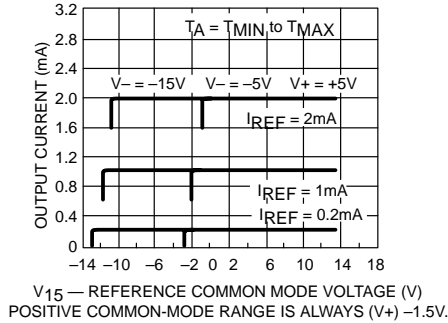

Logic Input Current vs Input Voltage

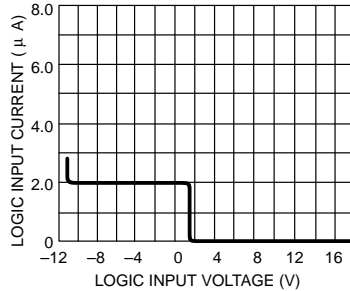

$V_{TH} - V_{LC}$ vs Temperature

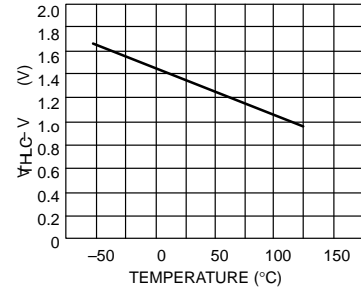

**Output Voltage Compliance
vs Temperature**

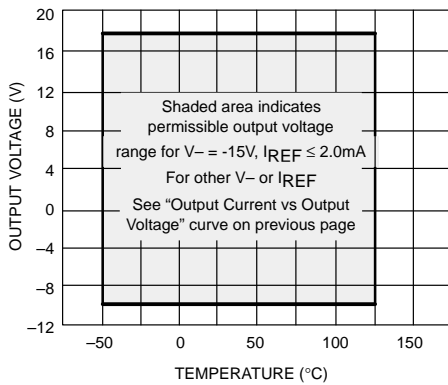

Bit Transfer Characteristics

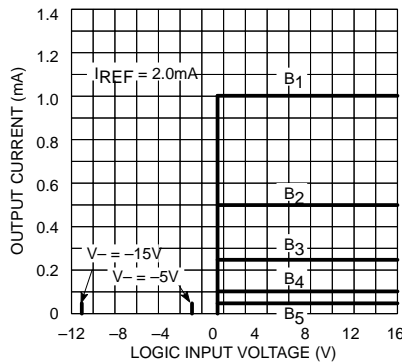

NOTES:

B1 through B6 have identical transfer characteristics. Bits are fully switched, with less than 1/2LSB error, at less than $\pm 100\text{mV}$ from actual threshold. These switching points are guaranteed to lie between 0.8 and 2.0V over the operating temperature range ($V_{LC} = 0.0\text{V}$).

Power Supply Current vs V_{+}

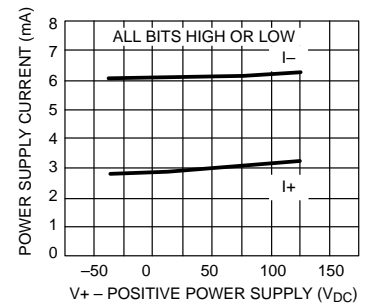

Power Supply Current vs V_{-}

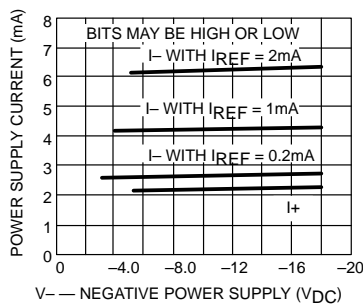

Power Supply Current vs Temperature

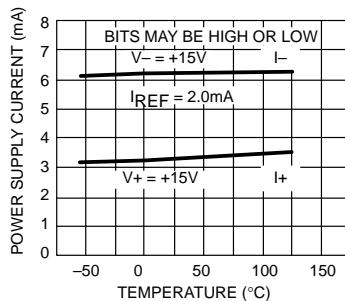

**Maximum Reference Input Frequency
vs Compensation Capacitor Value**

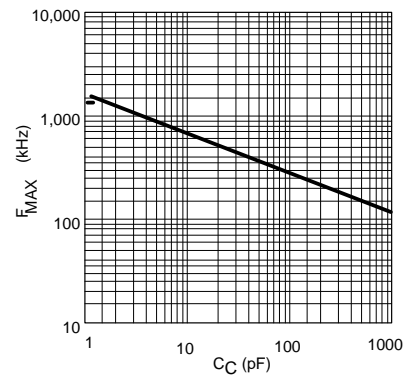

8-Bit high-speed multiplying D/A converter

DAC08 Series

TYPICAL APPLICATION

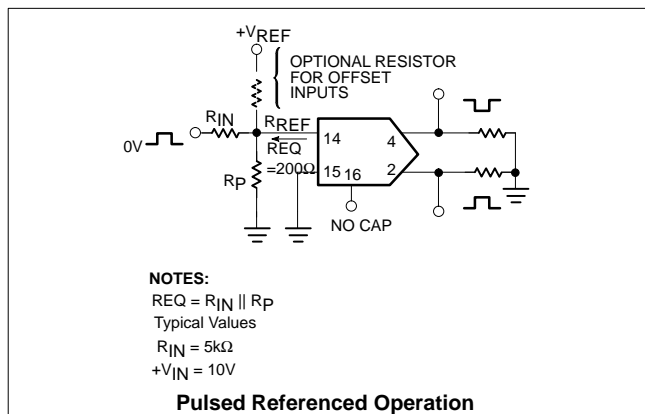

FUNCTIONAL DESCRIPTION

Reference Amplifier Drive and Compensation

The reference amplifier input current must always flow into Pin 14 regardless of the setup method or reference supply voltage polarity.

Connections for a positive reference voltage are shown in Figure 1. The reference voltage source supplies the full reference current. For bipolar reference signals, as in the multiplying mode, R_{15} can be tied to a negative voltage corresponding to the minimum input level. R_{15} may be eliminated with only a small sacrifice in accuracy and temperature drift.

The compensation capacitor value must be increased as R_{14} value is increased. This is in order to maintain proper phase margin. For R_{14} values of 1.0, 2.5, and 5.0k Ω , minimum capacitor values are 15, 37, and 75pF, respectively. The capacitor may be tied to either V_{EE} or ground, but using V_{EE} increases negative supply rejection. (Fluctuations in the negative supply have more effect on accuracy than do any changes in the positive supply.)

A negative reference voltage may be used if R_{14} is grounded and the reference voltage is applied to R_{15} as shown. A high input impedance is the main advantage of this method. The negative reference voltage must be at least 3.0V above the V_{EE} supply. Bipolar input signals may be handled by connecting R_{14} to a positive reference voltage equal to the peak positive input level at Pin 15.

When using a DC reference voltage, capacitive bypass to ground is recommended. The 5.0V logic supply is not recommended as a reference voltage, but if a well regulated 5.0V supply which drives logic is to be used as the reference, R_{14} should be formed of two series resistors with the junction of the two resistors bypassed with 0.1 μ F to ground. For reference voltages greater than 5.0V, a clamp diode is recommended between Pin 14 and ground.

If Pin 14 is driven by a high impedance such as a transistor current source, none of the above compensation methods applies and the amplifier must be heavily compensated, decreasing the overall bandwidth.

Output Voltage Range

The voltage at Pin 4 must always be at least 4.5V more positive than the voltage of the negative supply (Pin 3) when the reference current

is 2mA or less, and at least 8V more positive than the negative supply when the reference current is between 2mA and 4mA. This is necessary to avoid saturation of the output transistors, which would cause serious accuracy degradation.

Output Current Range

Any time the full-scale current exceeds 2mA, the negative supply must be at least 8V more negative than the output voltage. This is due to the increased internal voltage drops between the negative supply and the outputs with higher reference currents.

Accuracy

Absolute accuracy is the measure of each output current level with respect to its intended value, and is dependent upon relative accuracy, full-scale accuracy and full-scale current drift. Relative accuracy is the measure of each output current level as a fraction of the full-scale current after zero-scale current has been nulled out. The relative accuracy of the DAC08 series is essentially constant over the operating temperature range due to the excellent temperature tracking of the monolithic resistor ladder. The reference current may drift with temperature, causing a change in the absolute accuracy of output current. However, the DAC08 series has a very low full-scale current drift over the operating temperature range.

The DAC08 series is guaranteed accurate to within \pm LSB at +25 $^{\circ}$ C at a full-scale output current of 1.992mA. The relative accuracy test circuit is shown in Figure 1. The 12-bit converter is calibrated to a full-scale output current of 1.99219mA, then the DAC08 full-scale current is trimmed to the same value with R_{14} so that a zero value appears at the error amplifier output. The counter is activated and the error band may be displayed on the oscilloscope, detected by comparators, or stored in a peak detector.

Two 8-bit D-to-A converters may not be used to construct a 16-bit accurate D-to-A converter. 16-bit accuracy implies a total of \pm part in 65,536, or \pm 0.00076%, which is much more accurate than the \pm 0.19% specification of the DAC08 series.

Monotonicity

A monotonic converter is one which always provides analog output greater than or equal to the preceding value for a corresponding increment in the digital input code. The DAC08 series is monotonic for all values of reference current above 0.5mA. The recommended range for operation is a DC reference current between 0.5mA and 4.0mA.

Settling Time

The worst-case switching condition occurs when all bits are switched on, which corresponds to a low-to-high transition for all input bits. This time is typically 70ns for settling to within LSB for 8-bit accuracy. This time applies when $R_L < 500\Omega$ and $C_O < 25pF$. The slowest single switch is the least significant bit, which typically turns on and settles in 65ns. In applications where the DAC functions in a positive-going ramp mode, the worst-case condition does not occur and settling times less than 70ns may be realized.

Extra care must be taken in board layout since this usually is the dominant factor in satisfactory test results when measuring settling time. Short leads, 100 μ F supply bypassing for low frequencies, minimum scope lead length, and avoidance of ground loops are all mandatory.

8-Bit high-speed multiplying D/A converter

DAC08 Series

SETTLING TIME AND PROPAGATION DELAY

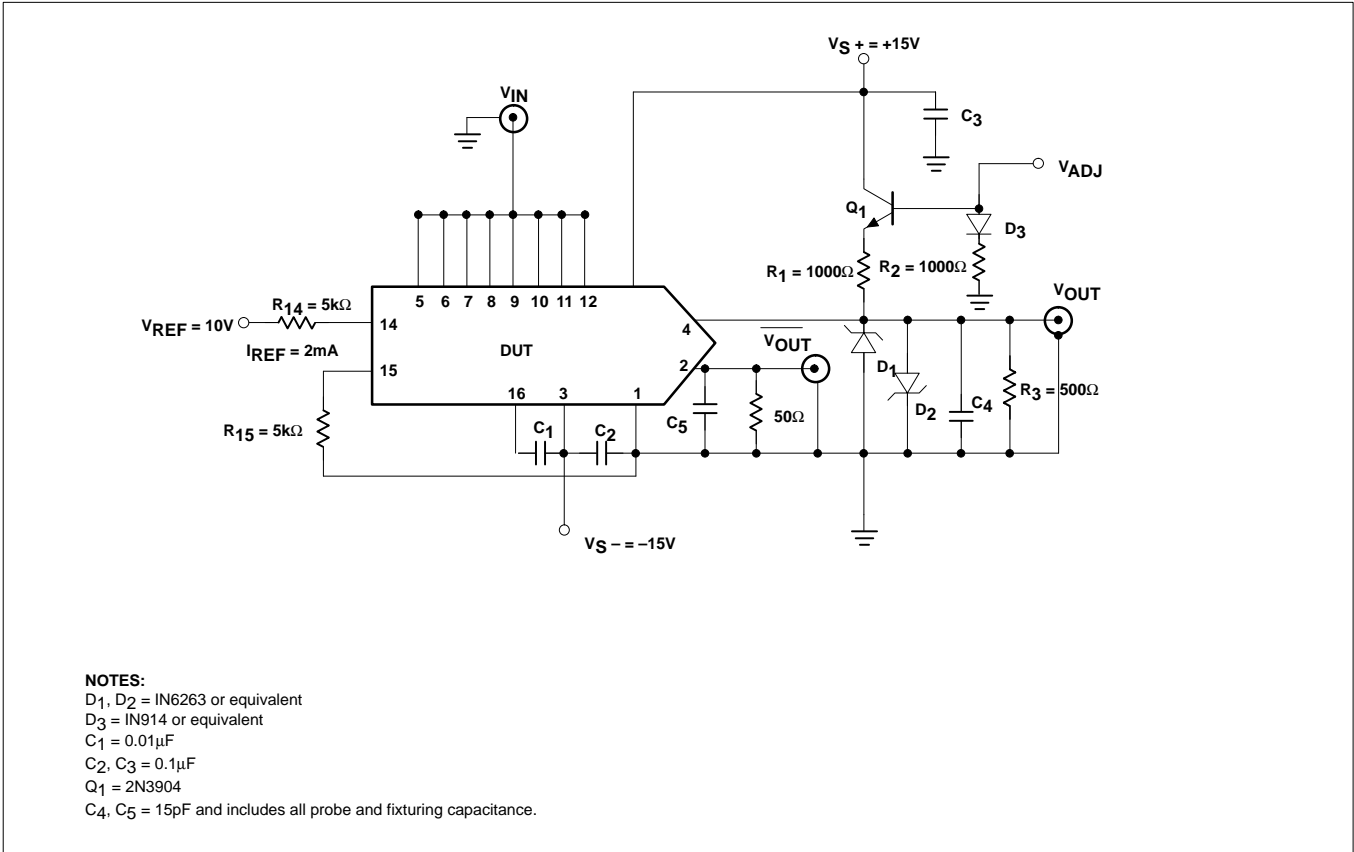

BASIC DAC08 CONFIGURATION

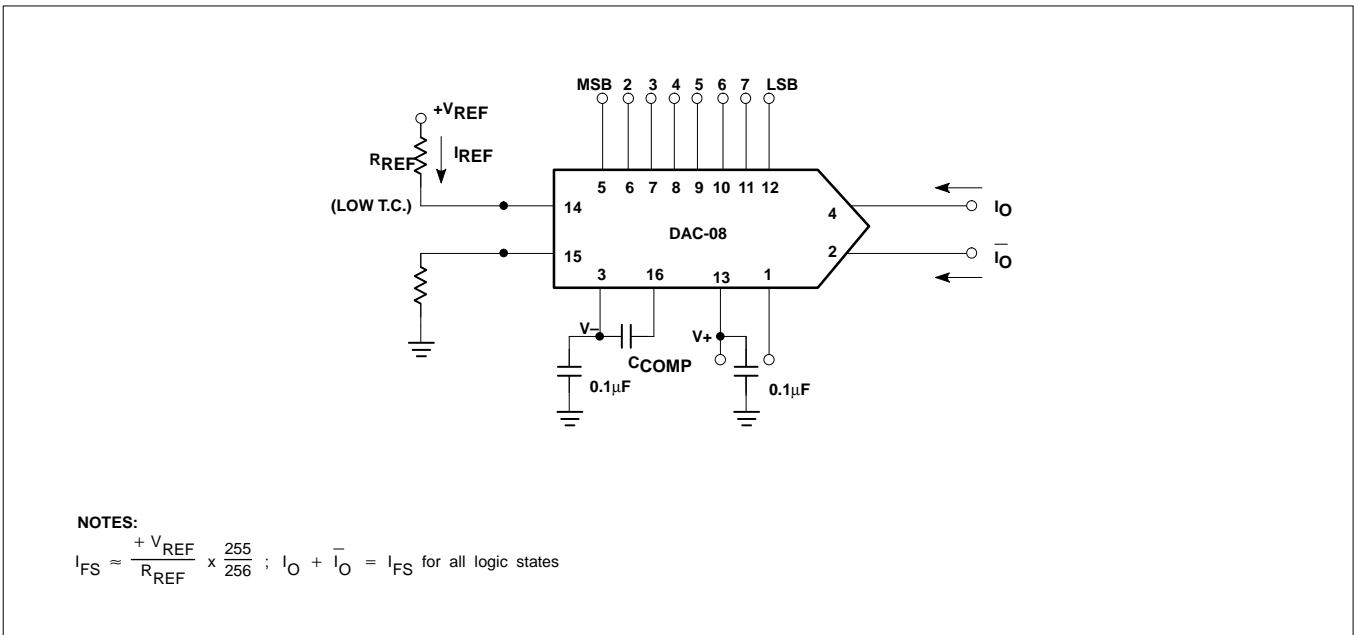

8-Bit high-speed multiplying D/A converter

DAC08 Series

RECOMMENDED FULL-SCALE AND ZERO-SCALE ADJUST

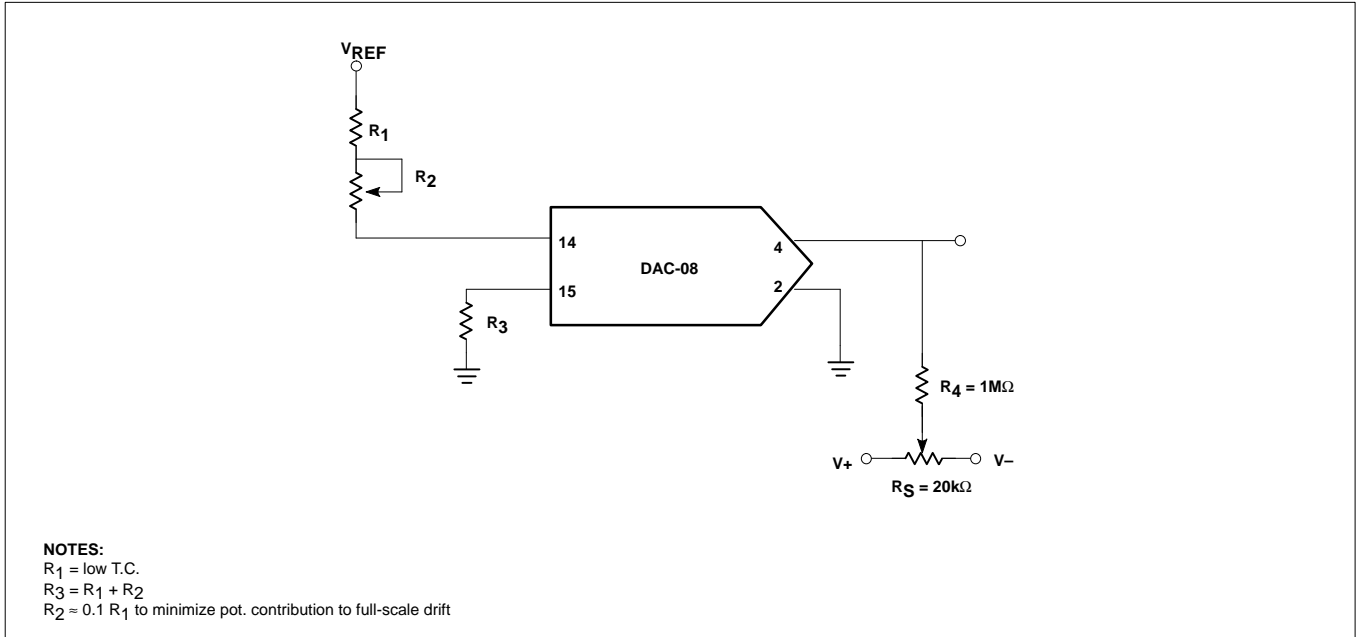

UNIPOLAR VOLTAGE OUTPUT FOR LOW IMPEDANCE OUTPUT

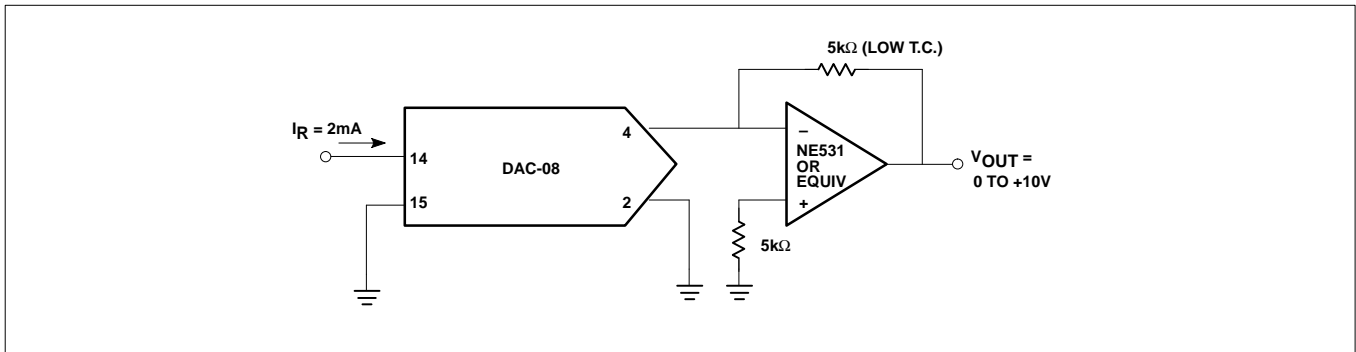

8-Bit high-speed multiplying D/A converter

DAC08 Series

UNIPOLAR VOLTAGE OUTPUT FOR HIGH IMPEDANCE OUTPUT

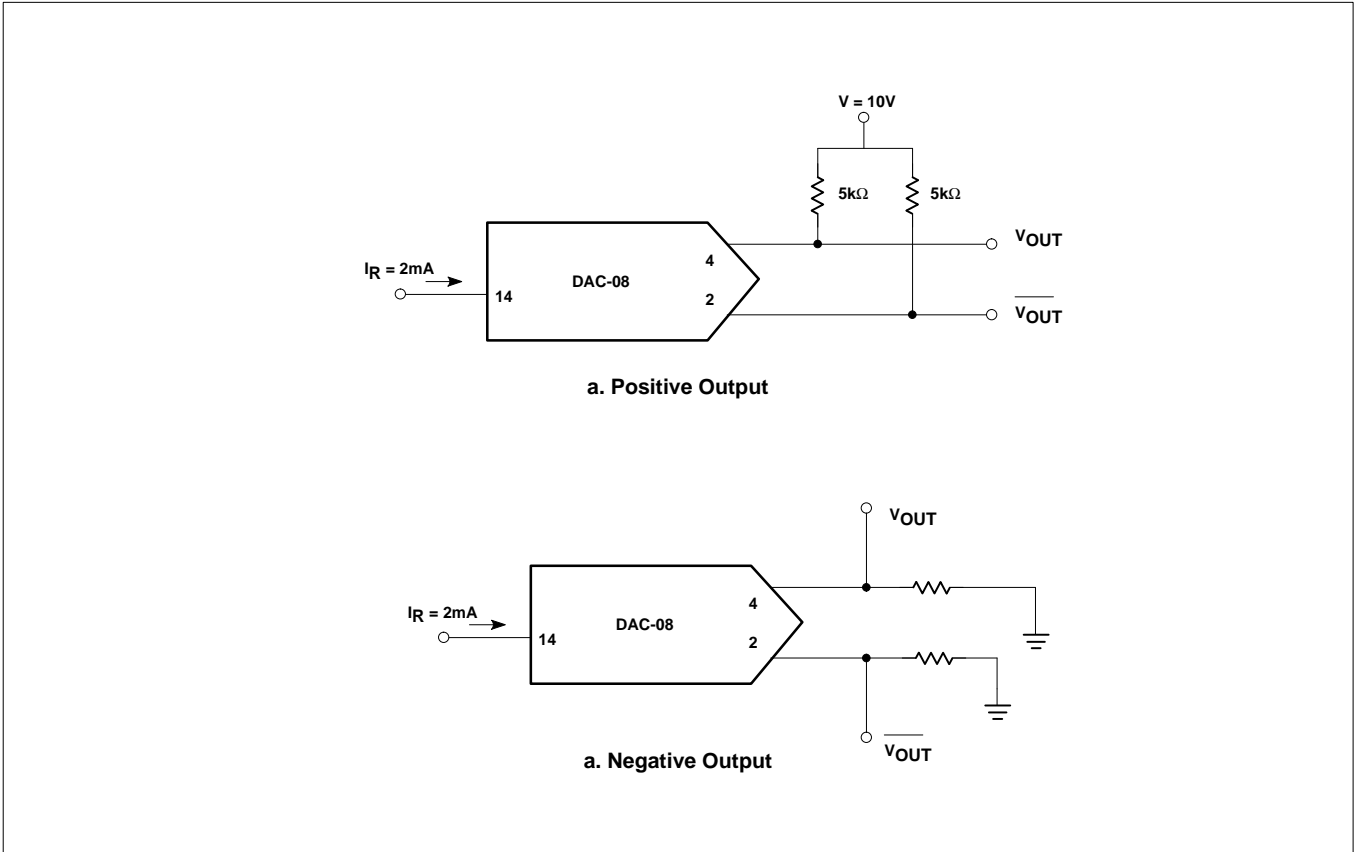

BASIC BIPOLAR OUTPUT OPERATION (OFFSET BINARY)

