



16-Bit High Speed Current-Output DAC

DAC16

FEATURES

- ±1 LSB Differential Linearity (max)
- Guaranteed Monotonic Over Temperature Range
- ±2 LSB Integral Linearity (max)
- 500 ns Settling Time
- 5 mA Full-Scale Output
- TTL/CMOS Compatible
- Low Power: 190 mW (typ)
- Available in Die Form

APPLICATIONS

- Communications
- ATE
- Data Acquisition Systems
- High Resolution Displays

FUNCTIONAL BLOCK DIAGRAM

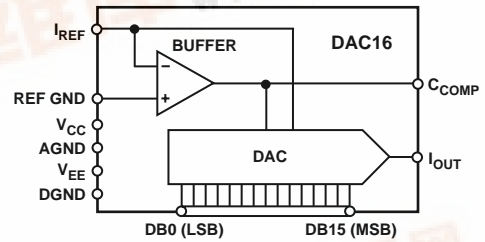

GENERAL DESCRIPTION

The DAC16 is a 16-bit high speed current-output digital-to-analog converter with a settling time of 500 ns. A unique combination of low distortion, high signal-to-noise ratio, and high speed make the DAC16 ideally suited to performing waveform synthesis and modulation in communications, instrumentation, and ATE systems. Input reference current is buffered, with full-scale output current of 5 mA. The 16-bit parallel digital input bus is TTL/CMOS compatible. Operating from +5 V and -15 V supplies, the DAC16 consumes 190 mW (typ) and is available in a 24-lead epoxy DIP, epoxy surface-mount small outline (SOL), and in die form.

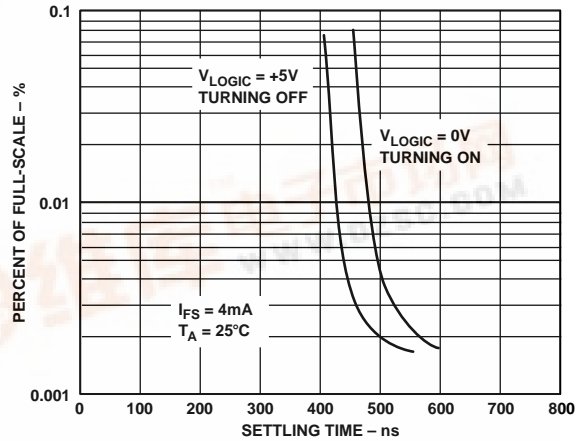

Figure 1. DAC16 Settling Time Accuracy vs. Percent of Full Scale

REV. B

Information furnished by Analog Devices is believed to be accurate and reliable. However, no responsibility is assumed by Analog Devices for its use, nor for any infringements of patents or other rights of third parties which may result from its use. No license is granted by implication or otherwise under any patent or patent rights of Analog Devices.

DAC16—SPECIFICATIONS

ELECTRICAL CHARACTERISTICS (@ $V_{CC} = +5.0\text{ V}$, $V_{EE} = -15.0\text{ V}$, $I_{REF} = 0.5\text{ mA}$, $C_{COMP} = 47\text{ }\mu\text{F}$, $T_A = \text{Full Operating Temperature Range unless otherwise noted. See Note 1 for supply variations.}$)

Parameter		Conditions	Min	Typ	Max	Units
Integral Linearity “G”	INL	$T_A = +25^\circ\text{C}$	-2	± 1.2	+2	LSB
Integral Linearity “G”	INL		-4	± 1.6	+4	LSB
Differential Linearity “G”	DNL	$T_A = +25^\circ\text{C}$	-1	± 0.5	+1	LSB
Differential Linearity “G”	DNL		-1	± 0.7	+1.5	LSB
Integral Linearity “F”	INL	$T_A = +25^\circ\text{C}$	-4	± 1.4	+4	LSB
Integral Linearity “F”	INL		-6	± 2	+6	LSB
Differential Linearity “F”	DNL	$T_A = +25^\circ\text{C}$	-1	± 0.5	+1.5	LSB
Differential Linearity “F”	DNL		-1.5	± 0.6	+2	LSB
Zero Scale Error	ZSE				1	LSB
Zero Scale Drift	TC_{ZSE}			0.025		ppm/ $^\circ\text{C}$
Gain Error	GE				± 0.225	% FS
Gain Drift	TC_{GE}			5		ppm/ $^\circ\text{C}$
REFERENCE²						
Reference Input Current	I_{REF}	Note 2	350		625	μA
OUTPUT CHARACTERISTICS						
Output Current	I_{OUT}	Note 2	2.8		5.0	mA
Output Capacitance	C_{OUT}			10		pF
Settling Time	t_S	0.003% of Full Scale		500		ns
LOGIC CHARACTERISTICS						
Logic Input High Voltage	V_{INH}	$T_A = +25^\circ\text{C}$	2.4			V
Logic Input Low Voltage	V_{INL}	$T_A = +25^\circ\text{C}$			0.8	V
Logic Input Current	I_{INH}	$V_{IN} = 5.0\text{ V}$, DB0–DB10			7.5	μA
Logic Input Current	I_{INH}	$V_{IN} = 5.0\text{ V}$, DB11–DB15			100	μA
Logic Input Current	I_{INL}	$V_{IN} = 0\text{ V}$, DB0–DB15			1	μA
Input Capacitance	C_{IN}			8		pF
SUPPLY CHARACTERISTICS						
Power Supply Sensitivity	PSS	$V_{CC} = 4.5\text{ V to }5.5\text{ V}$, $V_{EE} = -13\text{ V to }-17\text{ V}$			20	ppm/V
Positive Supply Current	I_{CC}	All Bits HIGH		15	22	mA
Positive Supply Current	I_{CC}	All Bits LOW		6	7.5	mA
Negative Supply Current	I_{EE}			7.5	10	mA
Power Dissipation	P_{DISS}			188	260	mW

NOTES

¹All supplies can be varied $\pm 5\%$ and operation is guaranteed. Device is tested with nominal supplies.

²Operation is guaranteed over this reference range, but linearity is neither tested nor guaranteed (see Figures 7 and 8).

Specifications subject to change without notice.

WAFER TEST LIMITS (@ $V_{CC} = +5.0\text{ V}$, $V_{EE} = -15.0\text{ V}$, $I_{REF} = 0.5\text{ mA}$, $C_{COMP} = 47\text{ }\mu\text{F}$, $T_A = +25^\circ\text{C}$ unless otherwise noted.)

Parameter	Symbol	Conditions	DAC16G Limit	Units
Integral Nonlinearity	INL		± 3	LSB max
Differential Nonlinearity	DNL		± 1	LSB max
Zero Scale Error	ZSE		± 1	LSB max
Gain Error	GE		± 12	% FS max
Logic Input High Voltage	V_{INH}		2.4	V min
Logic Input Low Voltage	V_{INL}		0.8	V max
Logic Input Current	I_{IN}		75	μA max
Positive Supply Current	I_{CC}		20	mA max
Negative Supply Current	I_{EE}		10	mA max
Power Dissipation	P_{DISS}		250	mW max

NOTE

Electrical tests are performed at wafer probe to the limits shown. Due to variations in assembly methods and normal yield loss, yield after packaging is not guaranteed for standard product dice. Consult factory to negotiate specifications based on dice lot qualification through sample lot assembly and testing.

DAC16

ABSOLUTE MAXIMUM RATINGS

($T_A = +25^\circ\text{C}$ unless otherwise noted)

V_{CC} to V_{EE}	-0.3 V, +25.0 V
V_{CC} to DGND	-0.3 V, +7.0 V
V_{EE} to AGND	+0.3 V, -18.0 V
DGND to AGND	-0.3 V, +0.3 V
REF GND to AGND	-0.3 V, +1.0 V
I_{REF}	1 mA
Analog Output Current	8 mA
Digital Input Voltage to DGND	$\leq V_{CC}$
Operating Temperature Range	
FP, FS	-40°C to +85°C
GS	0°C to +70°C
Dice Junction Temperature	+150°C
Storage Temperature	-65°C to +150°C
Power Dissipation	1000 mW
Lead Temperature (Soldering, 60 sec)	+300°C

Package Type	θ_{JA}^1	θ_{JC}	Units
24-Lead Plastic DIP (P)	62	32	$^\circ\text{C}/\text{W}$
24-Lead Plastic SOL (S)	70	22	$^\circ\text{C}/\text{W}$

NOTE

¹ θ_{JA} is specified for worst case mounting conditions, i.e., θ_{JA} is specified for device in socket.

DICE CHARACTERISTICS

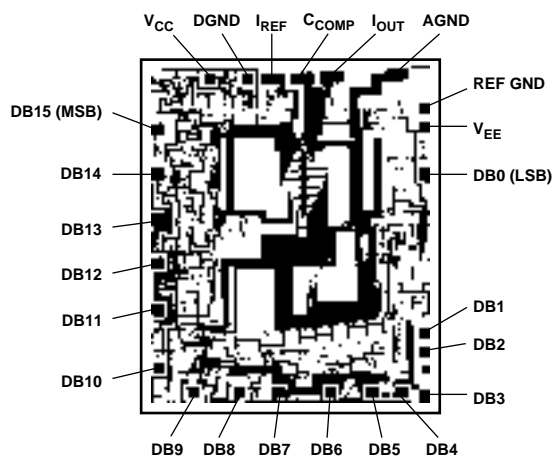

Die Size 0.129 x 0.153 inch, 19,737 sq. mils
(3.277 x 3.886 mm, 12.73 sq. mm)
The DAC16 Contains 330 Transistors.
Substrate is V_{EE} Polarity.

CAUTION

1. Stresses above those listed under “Absolute Maximum Ratings” may cause permanent damage to the device. This is a stress rating only and functional operation at or above this specification is not implied. Exposure to the above maximum rating conditions for extended periods may affect device reliability.
2. Digital inputs and outputs are protected; however, permanent damage may occur on unprotected units from high energy electrostatic fields. Keep units in conductive foam or packaging at all times until ready to use. Use proper anti-static handling procedures.
3. Remove power before inserting or removing units from their sockets.

PIN CONFIGURATION

24-Lead DIP (P, S)

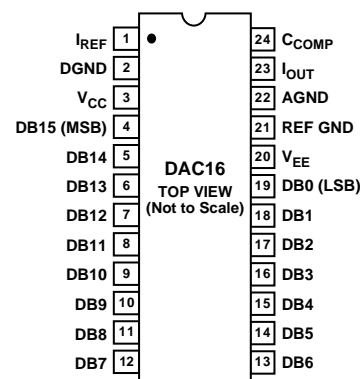

PIN DESCRIPTION

Pin (P, S)	Name	Description
1	I_{REF}	Reference Current Input
2	DGND	Digital Ground
3	V_{CC}	+5 V Digital Supply
4-19	DB15-DB0	16-Bit Digital Input Bus. DB15 is the MSB.
20	V_{EE}	-15 V Analog Supply
21	REF GND	Reference Current Return
22	AGND	Analog Ground/Output Reference
23	I_{OUT}	Current Output
24	C_{COMP}	Current Ladder Compensation

ORDERING GUIDE

Model	Grade DNL (max)	Temperature Ranges	Package Descriptions	Package Options
DAC16GS	± 1	0°C to +70°C	24-Lead SOL	R-24
DAC16FP	± 2	-40°C to +85°C	24-Lead PDIP	N-24
DAC16FS	± 2	-40°C to +85°C	24-Lead SOL	R-24
DAC16GBC	± 1	+25°C	Die	

DAC16

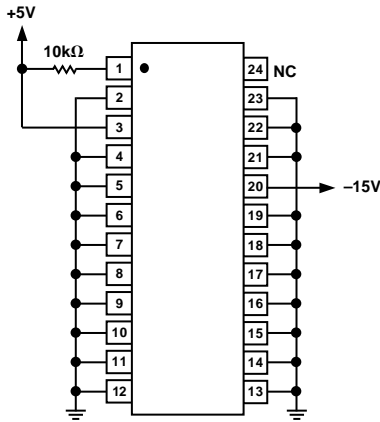

Figure 2. Burn-In Diagram

OPERATION

Novel DAC Architecture

The DAC16 was designed with a compound DAC architecture to achieve high accuracy, excellent linearity, and low transition errors. As shown in Figure 3, the DAC's five most-significant bits utilize 31 identical segmented current sources to obtain optimal high speed settling at major code transitions. The lower nine bits utilize an inverted R-2R ladder network which is laser-trimmed to ensure excellent differential nonlinearity. The middle two bits (DB9 and DB10) are binary-weighted and scaled from the MSB segments. Note that the flow of output current is into the DAC16—there is no signal inversion. As shown, the switches for each current source are essentially diodes. It is for this reason that the output voltage compliance of the DAC16 is limited to a few millivolts. The DAC16 was designed to operate with an operational amplifier configured as an I-V converter; therefore, the DAC16's output must be connected to the sum node of an operational amplifier for proper operation. Exceeding the output voltage compliance of the DAC16 will introduce linearity errors. The reference current buffer assures full accuracy and fast settling by controlling the MSB reference node. The 16-bit parallel digital input is TTL/CMOS compatible and unbuffered,

minimizing the deleterious effects of digital feedthrough while allowing the user to tailor the digital interface to the speed requirements and bus configuration of the application.

Equivalent Circuit Analysis

An equivalent circuit for static operation of the DAC16 is illustrated in Figure 4. I_{REF} is the current applied to the DAC16 and is set externally to the device by V_{REF} and R_{REF} . The output capacitance of the DAC16 is approximately 10 pF and is code independent. Its output resistance R_O is code dependent and is given by:

$$\frac{1}{R_O} = \frac{1}{8 \text{ k}\Omega} + \frac{DB9}{288 \text{ k}\Omega} + \frac{DB10}{144 \text{ k}\Omega} + \frac{X}{72 \text{ k}\Omega}$$

where

$DB9$ = State of Data Bit 9 = 0 or 1;

$DB10$ = State of Data Bit 10 = 0 or 1; and

X = Decimal representation of the 5 MSBs (DB11–DB15) = 0 to 31.

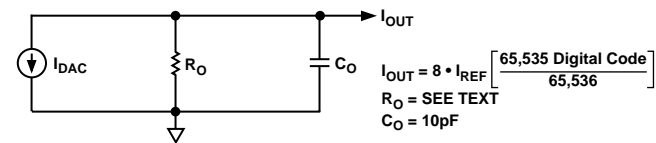

Figure 4. Equivalent Circuit for the DAC16

Table I provides the relationship between the input digital code and the output resistance of the DAC16.

Table I. DAC16 Output Resistance vs. Digital Code

Hex Digital Code	Scale	Output Resistance
FFFF	Zero	8 kΩ
BFFF	1/4	4.2 kΩ
7FFF	1/2	2.9 kΩ
3FFF	3/4	2.2 kΩ
0	Full – 1 LSB	1.8 kΩ

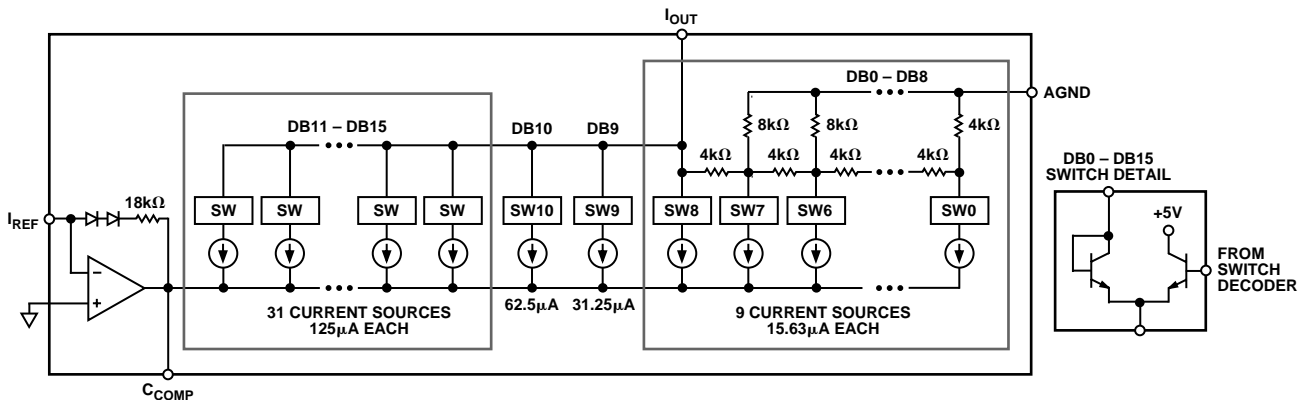

Figure 3. DAC16 Architecture

Typical Performance Characteristics—DAC16

Digital Input Considerations

The threshold of the DAC16's digital input circuitry is set at 1.4 V, independent of supply voltage. Hence, the digital inputs can interface with any type of 5 V logic. Illustrated in Figure 5 is the equivalent circuit of the digital inputs. Note that the individual input capacitance is approximately 7 pF.

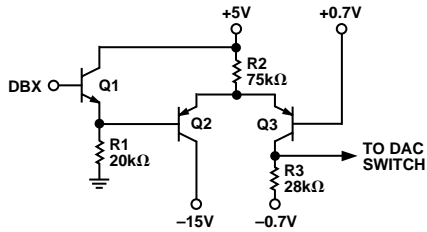

Figure 5. Equivalent Circuit of a DAC16 Digital Input

This input capacitance can be used in conjunction with an external R-C circuit for digital signal deskewing, if required. In applications where some of the DAC16's digital inputs are not used, the recommended procedure to turn off one or more inputs is to connect each input line to +5 V as shown in Figure 6.

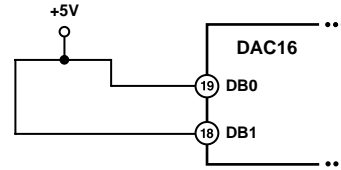

Figure 6. Handling Unused DAC16 Digital Inputs

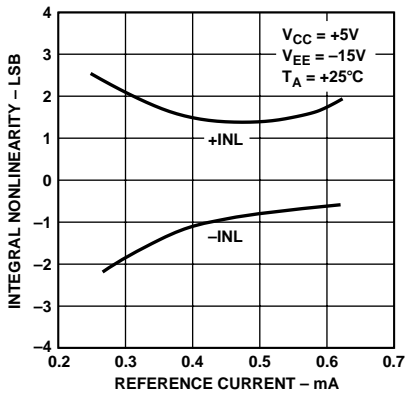

Figure 7. Integral Nonlinearity vs. I_{REF}

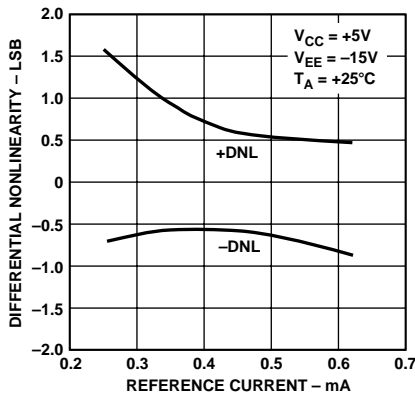

Figure 8. Differential Nonlinearity vs. I_{REF}

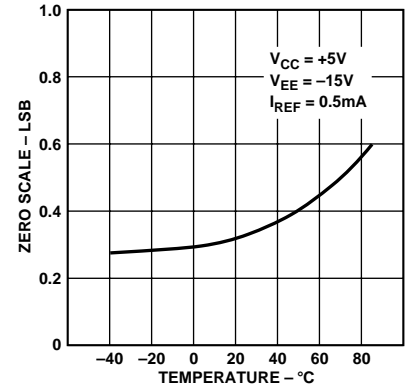

Figure 9. Zero Scale Output vs. Temperature

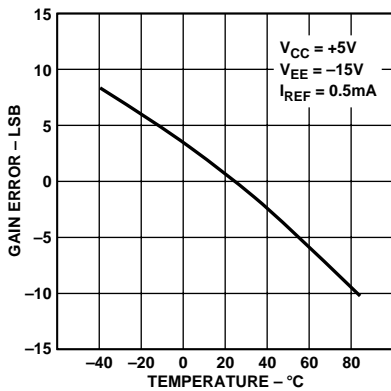

Figure 10. Gain Error vs. Temperature

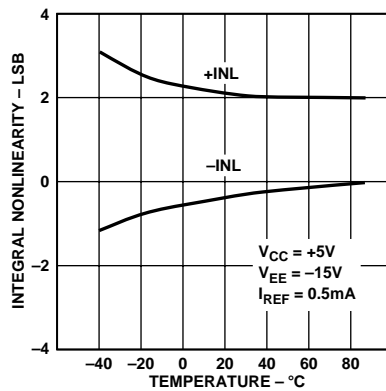

Figure 11. Integral Nonlinearity vs. Temperature

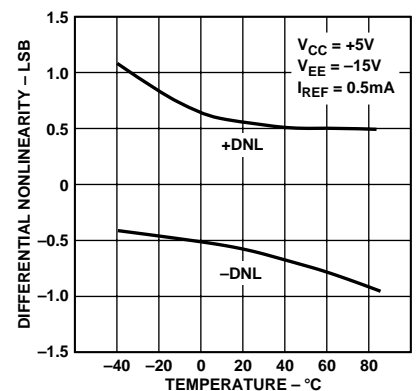

Figure 12. Differential Nonlinearity vs. Temperature

DAC16—Typical Performance Characteristics

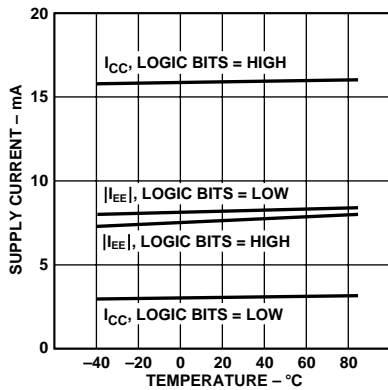

Figure 13. Supply Current vs. Temperature

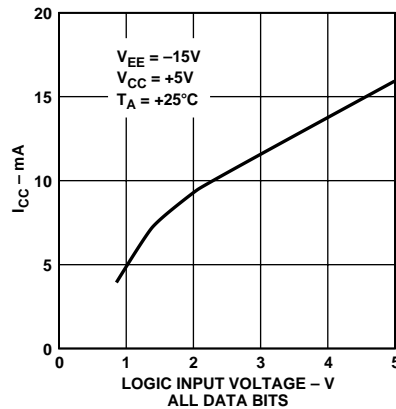

Figure 14. V_{CC} Supply Current vs. Logic Input Voltage, All Data Bits

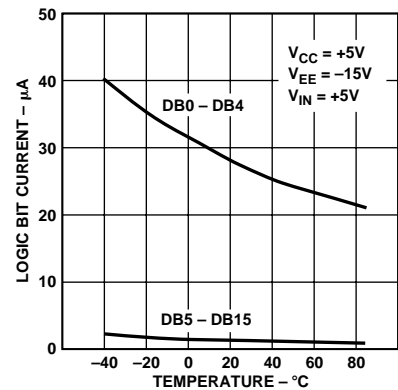

Figure 15. Digital Input Current vs. Temperature

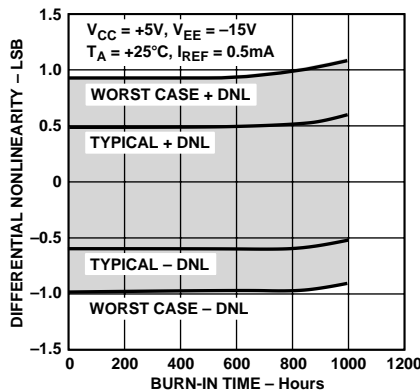

Figure 16. Differential Nonlinearity vs. Time Accelerated by Burn-In

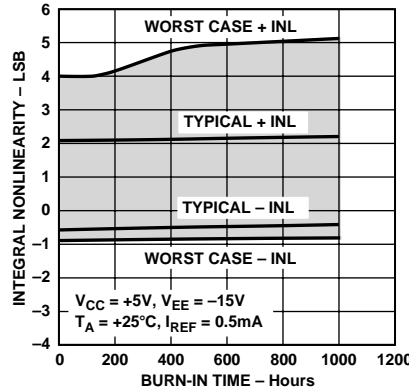

Figure 17. Integral Nonlinearity vs. Time Accelerated by Burn-In

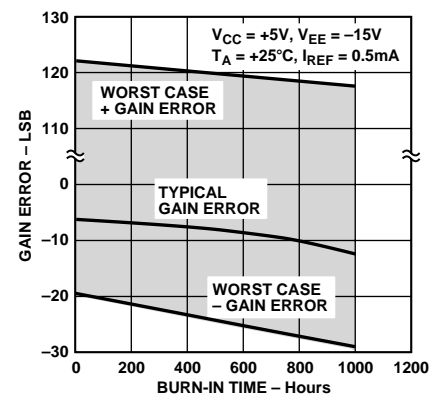

Figure 18. Gain Error vs. Time Accelerated by Burn-In

APPLICATIONS

Power Supplies, Bypassing, and Grounding

All precision converter products require careful application of good grounding practices to maintain full-rated performance. As is always the case with analog circuits operating in digital environments, digital noise is prevalent; therefore, special care must be taken to ensure that the DAC16's inherent precision is maintained. This means that particularly good engineering judgment should be exercised when addressing the power supply, grounding, and bypassing issues using the DAC16.

The DAC16 was designed to operate from +5 V and -15 V supplies. The +5 V supply primarily powers the digital portion of the DAC16 and can consume 20 mA, maximum. Although very little +5 V supply current is used by the reference amplifier, large amounts of digital noise present on the +5 V supply can introduce analog errors. It is, therefore, very important that the +5 V supply be well filtered and regulated. The -15 V supply provides most of the current for the reference amplifier and all of the current for the internal DAC. Although the maximum current in this supply is 10 mA, it must provide a low impedance path for the DAC switch currents. Therefore, it too must be well filtered and regulated.

The DAC16 includes two ground connections in order to minimize system accuracy degradation arising from grounding errors. The two ground pins are designated DGND (Pin 2) and AGND (Pin 22). The DGND pin is the return for the digital circuit sections of the DAC and serves as their input threshold reference point. Thus, DGND should be connected to the same ground as the circuitry that drives the digital inputs.

Pin 22, AGND, serves as the reference point for the 9-bit lower-order DAC as well as the common for the reference amplifier, REFGND (Pin 21). This pin should also serve as the reference point for all analog circuitry associated with the DAC16. Therefore, to minimize any errors, it is recommended that AGND connection on the DAC16 be connected to a high quality analog ground. If the system contains any analog signal path carrying a significant amount of current, then that path should have its own return connection to Pin 22.

It is often advisable to maintain separate analog and digital grounds throughout a complete system, tying them common to one place only. If the common tie point is remote and an accidental disconnection of that one common tie point were to occur due to card removal with power on, a large differential voltage between the two commons could develop. To protect devices that interface to both digital and analog parts of the

system, such as the DAC16, it is recommended that common ground tie points be provided at each such device. If only one system ground can be connected directly to the DAC16, it is recommended that the analog common be used. If the system's AGND has suitable low impedance, then the digital signal currents flowing in it should not seriously affect the ground noise. The amount of digital noise introduced by connecting the two grounds together at the device will not adversely affect system performance due to loss of digital noise immunity.

Generous bypassing of the DAC's supplies goes a long way in reducing supply-line induced errors. Even with well-filtered, well-regulated supplies, local bypassing consisting of 10 μF tantalum electrolytic shunted by a 0.1 μF ceramic is recommended. The decoupling capacitors should be connected between the DAC's supply pins (Pin 3 for +5 V, Pin 20 for -15 V) and the analog ground (Pin 22). Figure 19 shows how the DGND, AGND, and bypass connections should be made to the DAC16.

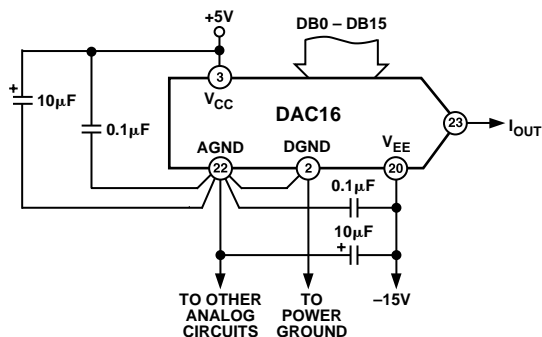

Figure 19. Recommended Grounding and Bypassing Scheme for the DAC16

Using the Right Capacitors

Probably the most important external components associated with high speed design are the capacitors used to bypass the power supplies and to provide compensation. Both selection and placement of these capacitors can be critical and, to a large extent, dependent upon the specifics of the system configuration. The dominant consideration in selection of bypass and compensation capacitors for the DAC16 is minimization of series resistance and inductance. Many capacitors begin to look inductive at 20 MHz and above—the very frequencies where rejection of interference is needed. Ceramic and film-type capacitors generally feature lower series inductance than tantalum or electrolytic types. A few general rules are of universal use when approaching the issue of compensation or bypassing.

Bypass capacitors should be installed on the printed circuit board with the shortest possible leads consistent with reliable construction. This helps to minimize series inductance in the leads. Chip capacitors are optimal in this respect. Where illustrated in the applications section, large tantalum electrolytic capacitors are shunted by low self-inductance ceramic capacitors. This technique reduces the self-resonance of the electrolytic while shifting the resonant frequency of the ceramics out-of-band.

Some series inductance between the DAC supply pins and the power supply plane often helps to filter out high frequency power supply noise. This inductance can be generated using a small ferrite bead as shown in Figure 20.

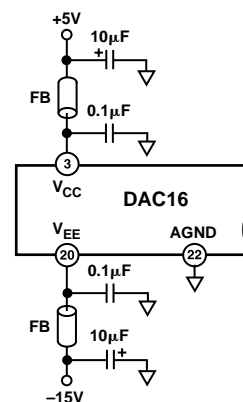

Figure 20. Using a Ferrite Bead as a High Frequency Filter

Reference Amplifier Considerations

The reference input current buffer is a high performance amplifier optimized for high accuracy and linearity. The design of the reference amplifier ensures fast settling times by tightly controlling the node common to all the current sources internal to the DAC with an external compensation capacitor (C_{COMP}). Since the primary design goal of the DAC16 is to achieve 16-bit performance, proper operation of the reference amplifier requires a 47 μF tantalum electrolytic capacitor shunted by a 0.1 μF ceramic capacitor, as shown in Figure 21. Increasing the capacitance at this node above the recommended values does not further reduce the analog transition current noise spikes at the output of the reference amplifier. Reducing the value of compensation, however, is not recommended as DAC linearity will degrade as a result. In most systems, the V_{EE} supply offers sufficiently low impedance to maintain a quiet return point for the reference amplifier. If this is not the case, the AGND point can also be used for the compensation capacitor return, as shown in Figure 21.

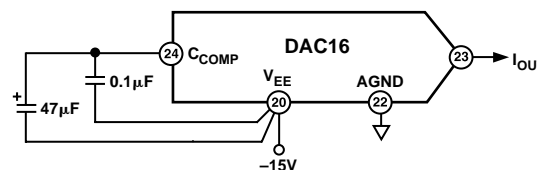

Figure 21a. Recommended Compensation Scheme to V_{EE}

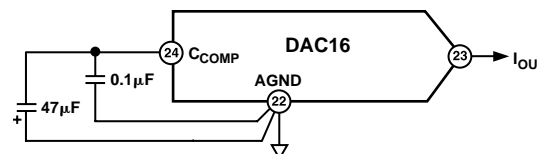

Figure 21b. Recommended Compensation Scheme to AGND

In applications where 16-bit multiplying performance is required, the DAC16 might appear to be a viable solution. However, the compensation capacitor network would have to be removed in these applications. The DAC16's reference amplifier was specifically designed for low frequency operation, with a compensation capacitor network. In fact, this network serves not only as a charge reservoir for the DAC's internal current sources but also as a wideband noise filter for the

DAC16

reference amplifier. Completely removing the compensation network would introduce large linearity errors, reference amplifier instability, wideband reference amplifier noise, and poor settling time.

Because the DAC exhibits an internal current scaling factor of eight times (8×), the reference amplifier requires only 500 μA input current from the user-supplied precision reference for a 4 mA full-scale output current. In applications that do not require such high output currents, good accuracy can be achieved with input reference currents in the range of $350 \mu\text{A} \leq I_{REF} \leq 625 \mu\text{A}$. The best signal-to-noise ratios, of course, will be achieved with a 625 μA reference current which yields a maximum 5 mA output current. Figure 22 illustrates how to form the reference input current with a REF02 and a 10 kΩ precision resistor.

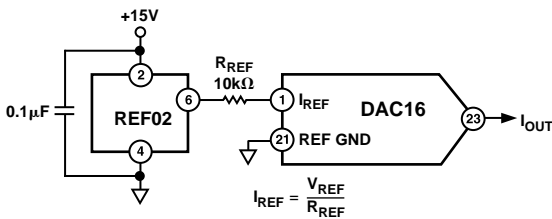

Figure 22. Generating the DAC16's Reference Input Current

Reducing Voltage Reference Noise

In data converters of 16-bit and greater resolution, noise is of critical importance. Surprisingly, the integrated voltage reference circuit used may contribute the dominant share of a system's noise floor, thereby degrading system dynamic range and signal-to-noise ratio. To maximize system dynamic range and SNR, all external noise contributions should be effectively much less than 1/2 LSB. For example, in a 5 V DAC16 application, one LSB is equivalent to 76 μV. This means that the total wideband noise contribution due to a voltage reference and all other sources should be less than 38 μV rms. These noise levels are not easy targets to hit with standard off-the-shelf reference devices. For example, commercially available references might exhibit 5 μV rms noise from 0.1 Hz to 10 Hz: but, over a 100 kHz bandwidth, its 300 μV rms of noise can easily swamp out a 16-bit system. Such noisy behavior can degrade a DAC's effective resolution by increasing its differential nonlinearity which, in turn, can lead to nonmonotonic behavior or analog errors.

The easiest way to reduce noise in the reference circuit is to band-limit its noise before feeding it to the converter. In the case of the DAC16, the reference is not a voltage, but a current. Illustrated in Figure 23 is a simple way of hand-limiting

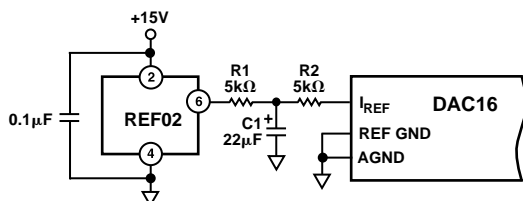

Figure 23. Filtering a Reference's Wideband Noise

voltage reference noise by splitting R_{REF} into two equal resistors and bypassing the common node with a capacitor. To minimize thermally induced errors, R1 and R2 must be electrically and

thermally well-matched. Thin-film resistor networks work well here. In this circuit, the parallel combination of R1 and R2 forms a 3 Hz low-pass filter with C1. The only noise source that remains is the thermal noise of R2 which can be a significantly lower noise generator than the voltage reference.

Input Coding

The unipolar digital input coding of the DAC16 employs negative logic to control the output current; that is, an all zero input code (0000_H) yields an output current 1 LSB below full scale. Conversely, an all 1s input code (FFFF_H) yields a zero analog current output. An expression for the DAC16's transfer equation can be expressed by:

$$I_{OUT} = 8 \times I_{REF} \times \left[\frac{65,535 - \text{Digital Code}}{65,536} \right]$$

Table II provides the relationship between the digital input codes and the output current of the DAC16.

Table II. Unipolar Code Table

Digital Input Word (Hex)	DAC16 Output Current I_{OUT}	Comment
0000	$8 \times (2^{16} - 1)/2^{16} \times I_{REF}$	Full Scale
7FFE	$8 \times (2^{15} + 1)/2^{16} \times I_{REF}$	Midscale + 1 LSB
7FFF	$8 \times (2^{15}/2^{16}) \times I_{REF}$	Midscale
8000	$8 \times (2^{15} - 1)/2^{16} \times I_{REF}$	Midscale - 1 LSB
FFFF	0	Zero Scale

Since the DAC16 exhibits a small output voltage compliance on the order of a few millivolts, a high accuracy operational amplifier must be used to convert the DAC's output current to a voltage. Refer to the section on selecting operation amplifiers for the DAC16. The circuit shown in Figure 24 illustrates a unipolar output configuration. In symbolic form, the transfer equation for this circuit can be expressed by:

$$V_O = R3 \times 8 \times I_{REF} \left[\frac{65,535 - \text{Digital Code}}{65,536} \right]$$

In this example, the reference input current was set to 500 μA which produces a full-scale output current of 4 mA - 1 LSB. The DAC's output current was scaled by R3, a 1.25 kΩ resistor, to produce a 5 V full-scale output voltage. Bear in mind that to ensure the highest possible accuracy, matched thin-film resistor networks are almost a necessity, not an option. The resistors used in the circuit must have close tolerance and tight thermal tracking. Table III illustrates the relationship between the input digital code and the circuit's output voltage for the component values shown.

Table III. Unipolar Output Voltage vs. Digital Input Code

Digital Input Word (Hex)	Decimal Number in DAC Decoder	Analog Output Voltage (V)
0000	65,535	4.999924
7FFE	32,769	2.500076
7FFF	32,768	2.500000
8000	32,767	2.499924
FFFF	0	0

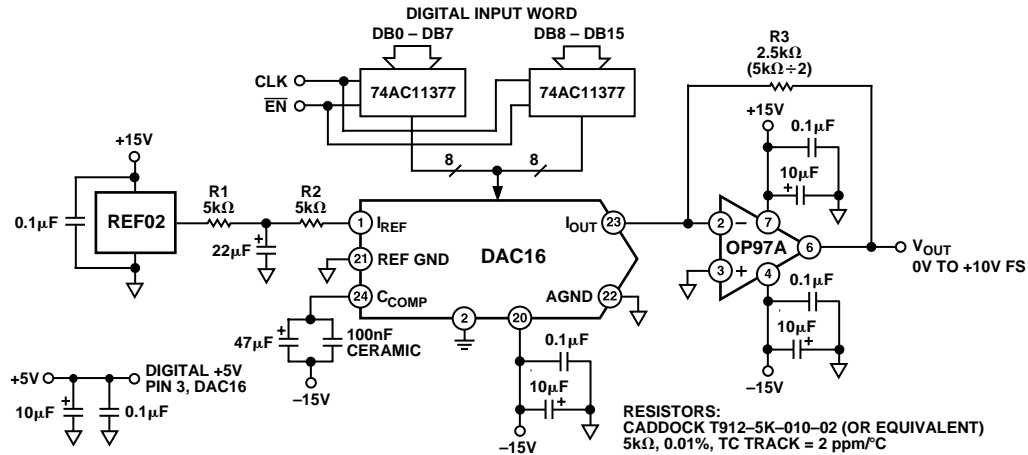

Figure 24. Unipolar Circuit Configuration

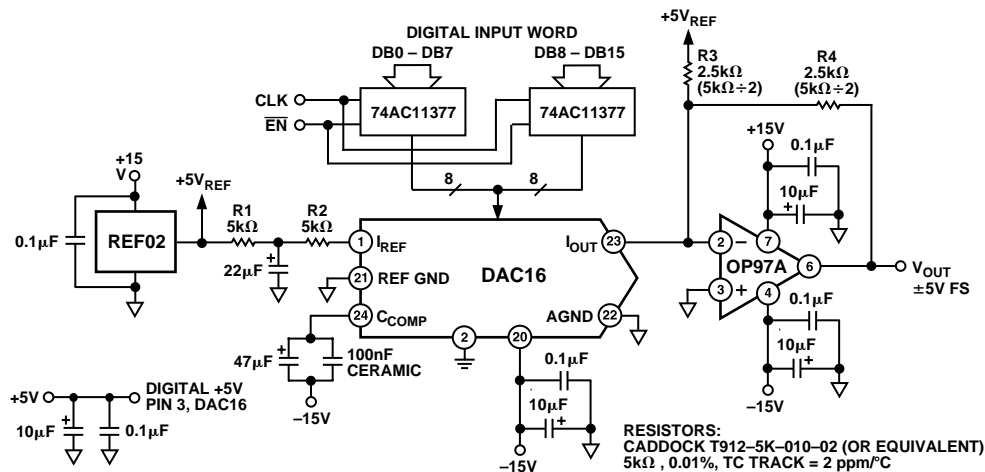

Figure 25. Bipolar Circuit Configuration

Bipolar Configuration

For applications that require a bipolar output voltage, the circuit in Figure 24 can be modified slightly by adding a resistor from the reference to the inverting sum node of the output amplifier to level shift the output signal. The transfer equation for the circuit now becomes:

$$V_O = R4 \times 8 \times I_{REF} \left[\frac{65,535 - \text{Digital Code}}{65,536} \right] - V_{REF} \times \left(\frac{R4}{R3} \right)$$

The circuit has the form shown in Figure 25, and Table IV provides the relationship between the digital input code and the circuit's output voltage for the component values shown.

Table IV. Bipolar Output Operation vs. Digital Input Code

Digital Input Word (Hex)	Decimal Number in DAC Decoder	Analog Output Voltage (V)
0000	65,535	4.999848
7FFE	32,769	152E-6
7FFF	32,768	0
8000	32,767	-152E-6
FFFF	0	-5.00000

DAC16

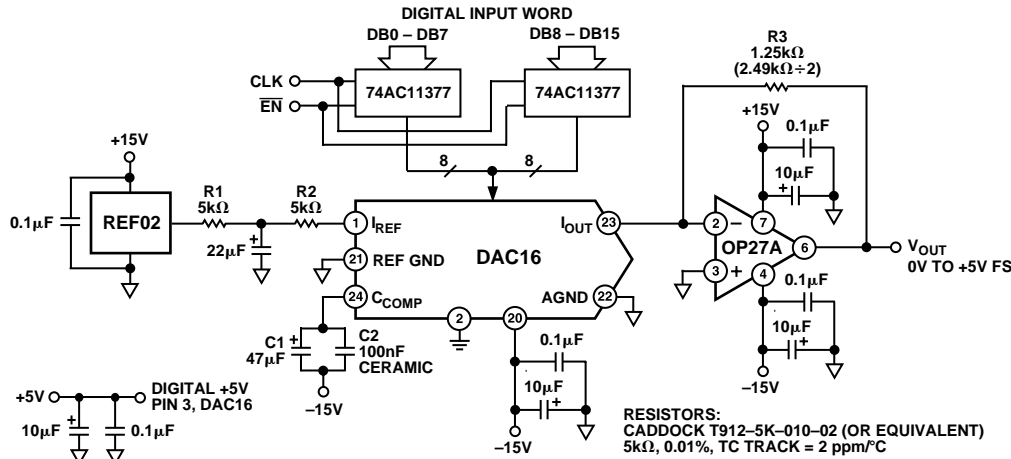

Figure 26. DAC16 Noise Measurement Test Circuit

DAC16 Noise Performance

The novel architecture employed in the DAC16 yields very low wideband noise. Figure 26 illustrates the circuit configuration for evaluating the DAC16's noise performance. An OP27 is used as the DAC16's output I-V converter which is configured to produce a 5 V full-scale output voltage. The output of the OP27 was then capacitively coupled to an OP37 stage configured in a gain of 101. Note that the techniques for reducing wideband noise of the voltage reference and the DAC's internal reference amplifier were used. As a result of these techniques, the DAC16 exhibited a full-scale output noise spectral density of $31 \text{ pA}/\sqrt{\text{Hz}}$ at 1 kHz.

Digital Feedthrough and Data Skew

The DAC16 features a compound DAC architecture where the 5 most significant bits utilize 31 identical, segmented current sources to obtain optimal high speed settling at major code transitions. Although every effort has been made to equalize the speeds at which the DAC switches operate, there exists finite skew in the MSB DAC switches.

As with any converter product, a high speed digital-to-analog converter is forced to exist on the frontier between the noisy environment of high speed digital logic and the sensitive analog domain. The problems of this interlace are particularly acute when demands of high speed (greater than 10 MHz switching times) and high precision are combined. No amount of design effort can perfectly isolate the analog portions of a DAC from the spectral components of a digital input signal with a 2 ns rise time. Inevitably, once this digital signal is brought onto the chip, some of its higher frequency components will find their way to the sensitive analog nodes, producing a digital feedthrough glitch. To minimize the exposure to this effect, the DAC16 was designed to omit intentionally the on-board latches that are usually included in many slower DACs. This not only reduces the overall level of digital activity on chip, it also avoids bringing a latch clock pulse onto the IC, whose opposite edge inevitably produces a substantial glitch, even when the DAC is not supposed to be changing codes.

The DAC16 uses each digital input line to switch each current segment in the DAC between the output diode-connected transistor and the logic control transistor. If the input bits are not changed simultaneously, or if the different DAC bits switch

at different speeds, then the DAC output current will momentarily take on some incorrect value. This effect is particularly troublesome at the "carry points," where the DAC output is to change by only one LSB, but several of the larger current sources must be switched to realize this change. Data skew can allow the DAC output to move a substantial amount towards full scale or zero (depending upon the direction of the skew) when only a small transition is desired. The glitch-sensitive user should be equally diligent about minimizing the data skew at the DAC16's inputs, particularly the five most significant bits. This can be achieved by using the proper logic family and gate to drive the DAC inputs, and keeping the interconnect lines between the latches and the DAC inputs as short and as well matched as possible. Logic families that were empirically determined to operate well with the DAC16 are devices from the 74AC11xxx and 74ACT11xxx advanced CMOS logic families. These devices have been purposely designed with improved layout and tailored rise times for minimizing ground bounce and digital feedthrough.

Deglinting

The output glitch of the DAC16 at the major carry (7FFE_H to 7FFF_H) is a not-insignificant 360 pA-sec, manifested as a momentary output transition to the negative rail for approximately 200 ns. Due to the inherent low-pass or time-sampled nature of many systems, this behavior in the DAC16 is not noticeable and does not detract from overall performance. Some applications however may prove so sensitive to glitch impulse that reduction by an order of magnitude or more is required. In order to realize low glitch impulses, some sort of sample-and-hold amplifier-based deglitching scheme must be used.

There are high speed SHAs available with specifications sufficient to deglitch the DAC16; however, most are hybrid in topology at costs which can be prohibitive. A high performance, low cost alternative shown in Figure 27 is a discrete SHA utilizing a high speed monolithic op amp and high speed DMOS FET switches.

This SHA circuit uses the inverting integrator structure. A 300 MHz gain-bandwidth product op amp, the AD841, is the heart of this fast SHA. The time constant formed by the 200 Ω resistor and the 100 pF capacitor determines the acquisition time and also hand limits the output signal to eliminate slew-induced distortion.

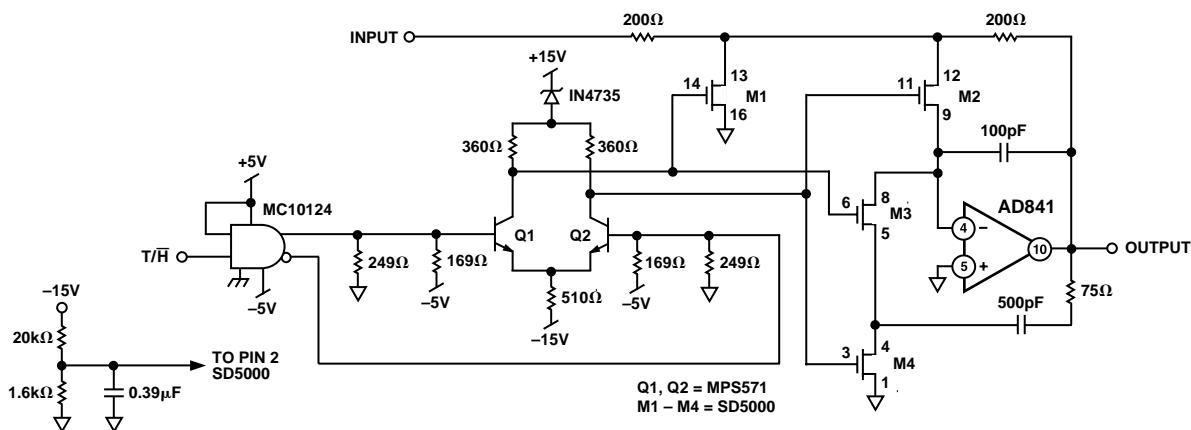

Figure 27. A High Performance Deglitching Circuit

A discrete drive circuit is used to achieve the best performance from the SD5000 quad DMOS switch. This switch-driving cell is composed of MPS571 RF NPN transistors and an MC10124 TTL-to-ECL translator. Using this technique provides both high speed and highly symmetrical drive signals for the SD5000 switches. The switches are arranged in a single-pole, double-throw (SPDT) configuration. The 500 pF “flyback” capacitor is switched to the op amp summing junction during the hold mode to keep switching transients from feeding to the output. This capacitor is grounded during sample mode to minimize its effect on acquisition time.

Careful circuit layout of the high speed SHA section is almost as important as the design itself. Double-sided printed circuit board, a compact layout, and short critical signal paths all ensure best performance.

Op Amp Selection

When selecting the amplifier to be used for the DAC16’s I–V converter, there are two main application areas; those requiring high accuracy, and those seeking high speed. In high accuracy applications, three parameters are of prime importance: (1) input offset voltage, V_{OS} ; (2) input bias current, $-I_B$; and (3) offset voltage drift, TCV_{OS} . In these applications where 16-bit performance must be maintained with an external reference at +5 V, an op amp’s input offset voltage must be less than 15 μ V (≈ 0.1 LSB) with a bias current less than 6 nA. The op amp must also exhibit high open-loop gain to keep the offset voltage below this limit over the specified full-scale output range. Thus, for a maximum output of 5 V, the op amp’s open loop gain must be greater than 1300 V/mV.

For low frequency, high accuracy applications, Table IV lists selected compatible operational amplifiers available from Analog Devices. These operational amplifiers satisfy all the above requirements and in most all cases will not require offset voltage nulling.

Table V. Precision Operational Amplifier the DAC16

Model	V_{OS}	TCV_{OS}	I_B	A_{VOL}
OP177	10 μ V	0.3 μ V/ $^{\circ}$ C	2 nA	12000 V/mV
OP77	25 μ V	0.6 μ V/ $^{\circ}$ C	2.8 nA	2000 V/mV
OP27	25 μ V	0.3 μ V/ $^{\circ}$ C	80 nA	1500 V/mV
OP97	25 μ V	2 μ V/ $^{\circ}$ C	0.15 nA	2000 V/mV

In high speed applications where resolution is more important than absolute accuracy, operational amplifiers such as the AD843 offer the requisite settling time. Although these amplifiers are not specified for 16-bit performance, their settling times are two to three times faster than the DAC16 and will introduce negligible error to the overall circuit’s settling time. It is possible to estimate the 16-bit settling time of an operational amplifier if its 12-bit settling time is known. Assuming that the op amp can be modeled by a single-pole response, then the ratio of the op amp’s 16-bit settling time to its 12-bit settling can be expressed as:

$$\frac{t_s(16-bit)}{t_s(12-bit)} = 1.33$$

Since many operational amplifier data sheets provide charts illustrating 0.01% settling time versus output voltage step size, all that is required to estimate an op amp’s 16-bit settling time is to multiply the 12-bit settling time for the required full-scale voltage by 1.33. The circuit’s overall settling time can then be approximated by the root-sum-square method:

$$t_S = \sqrt{(t_{DAC})^2 + (t_{OA})^2}$$

where

t_{DAC} = DAC16’s specified full-scale settling time

t_{OA} = Op amp full-scale settling time

As a design aid, Table VI illustrates a high speed operational amplifier selector guide for devices compatible with the DAC16 for high speed applications. All these devices exhibit the requisite settling time, input offset voltage, and input bias current consistent with maximum performance.

Table VI. High Speed Operational Amplifiers for the DAC16

Model	t_s to %	V_{OS}	TCV_{OS}	I_B	A_{VOL}
OP467	200 ns –0.01	0.5 mV	3.5 μ V/ $^{\circ}$ C	0.5 μ A	20 V/mV
AD817	70 ns –0.01	2 mV	10 μ V/ $^{\circ}$ C	6.6 μ A	6 V/mV
AD829	90 ns –0.1	0.5 mV	0.3 μ V/ $^{\circ}$ C	7 μ A	100 V/mV
AD841	110 ns –0.01	1 mV	35 μ V/ $^{\circ}$ C	5 μ A	45 V/mV
AD843	135 ns –0.01	1 mV	12 μ V/ $^{\circ}$ C	0.001 μ A	25 V/mV
AD845	350 ns –0.01	0.25 mV	5 μ V/ $^{\circ}$ C	0.001 μ A	500 V/mV
AD847	120 ns –0.01	1 mV	15 μ V/ $^{\circ}$ C	5 μ A	5.5 V/mV

DAC16

In using high speed op amps, the output capacitance of the DAC16 appears across the inputs of the op amp where it and the op amp's input capacitance will set an additional pole in the op amp's loop gain response. The pole is formed with the feedback resistance and the output resistance of the DAC. This additional pole may adversely affect the transient response of the circuit due to the added phase shift. Placing a small capacitor across the feedback resistance, as shown in Figure 28, compensates for the additional pole. The value of the capacitor can be determined by setting $R_{FB}C_{FB} = R_O (C_O + C_{IN})$ and should be adjusted for optimum transient response.

The choice of amplifier depends entirely on the required system accuracy, the required temperature range, and the operating frequency.

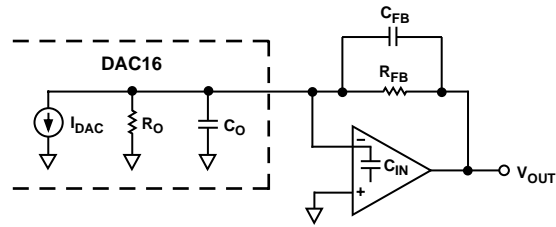
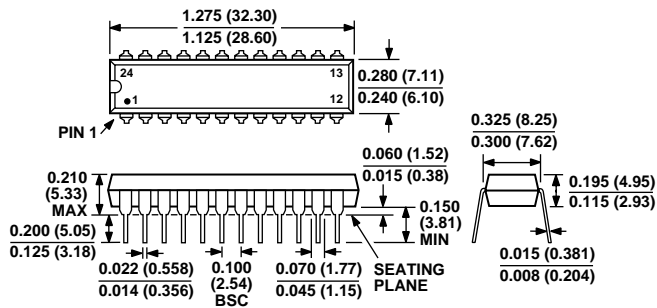

Figure 28. Compensating for the Feedback Pole

OUTLINE DIMENSIONS

Dimensions shown in inches and (mm).

24-Lead Epoxy DIP (P) (N-24)



24-Lead Epoxy SOL (S) (R-24)

